

**TYPICAL SECTION**  
**PROPOSED BULKHEAD**  
**VAN BUREN STREET**  
**HALSTED STREET**  
**HARRISON STREET**

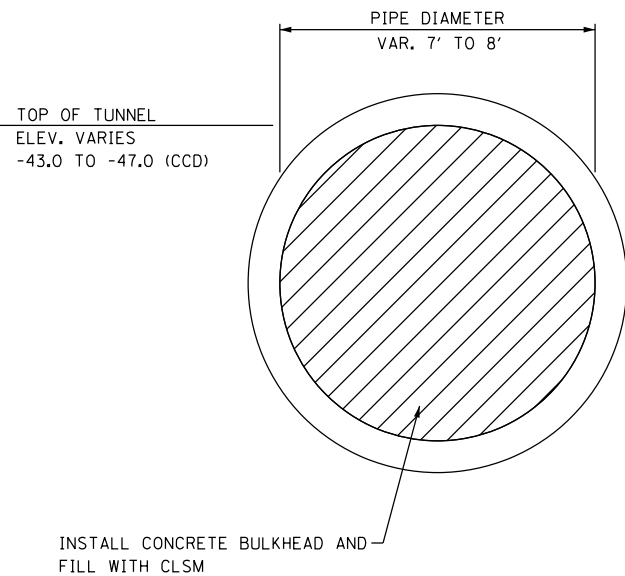

**TYPICAL SECTION**  
**EXISTING WATER TUNNEL**  
**VAN BUREN STREET**  
**HALSTED STREET**  
**HARRISON STREET**

**TUNNEL NOTES:**

THE WATER TUNNELS SHOWN ARE FROM CDWM RECORD DRAWINGS AND ARE INCLUDED FOR CONTRACTOR INFORMATION. IT SHALL BE THE CONTRACTOR'S RESPONSIBILITY TO ACCURATELY LOCATE THE CROWN OF THE WATER TUNNELS USING PROBE BORINGS, PER CDWM REQUIREMENTS.

THE EXISTING WATER TUNNELS ARE ABANDONED. THE CONTRACTOR SHALL PROVIDE DEWATERING AS NEEDED IN THE EXISTING WATER TUNNELS. THE MAXIMUM DISCHARGE RATE SHALL BE 300 GPM. FOR ABANDONED AND INACCESSIBLE TUNNELS, THE CONTRACTOR SHALL TAKE INTO CONSIDERATION THAT WATER HAS INFILTRATED THE EXISTING TUNNELS AND THEY ARE FILED TO CAPACITY WITHIN AND BEYOND THE PROJECT LIMITS. THIS WORK WILL NOT BE PAID FOR SEPARATELY, BUT INCLUDED IN THE COST OF CONTROLLED LOW STRENGTH MATERIAL (SPECIAL).

OBTAIN TWO CORE SAMPLES PER BULKHEAD, ONE (1) AT THE 10 AND ONE (1) AT THE 4 O'CLOCK POSITIONS OR ONE (1) AT THE 2 AND ONE (1) AT THE 8 O'CLOCK POSITIONS FOR COMPRESSION STRENGTH TESTING.

INSTALLATION OF GROUT OR CLSM SHALL NOT TAKE PLACE UNTIL THE CONCRETE STRENGTH OF THE BULKHEAD ACHIEVES 2,000 PSI IN 2-3 DAYS AFTER PLACEMENT. CONCRETE CYLINDERS SHALL BE CAST AND BROKEN TO VERIFY THE BULKHEAD CONCRETE COMPRESSIVE STRENGTH. SUBMIT THE TEST RESULTS TO THE ENGINEER FOR APPROVAL.

THE GROUT OR CLSM SHALL HAVE A MINIMUM SPREAD DIAMETER OF 20-INCHES USING AN INVERTED SLUMP CONE, APPROVED BY THE ENGINEER.

THE WATER TUNNEL AND SHAFT FILLING SHALL BE PERFORMED IN FOUR (4) LIFTS. THE FOURTH LIFT INTO THE DRILLED ACCESS HOLE SHALL EXTEND A MINIMUM OF 10 FEET ABOVE THE TOP OF THE EXISTING CROWN OF THE WATER TUNNEL. THE CONTRACTOR SHALL LET THE CLSM SET A MINIMUM 24-HOUR PERIOD BETWEEN LIFTS. THE MINIMUM STRENGTH OF THE CLSM SHALL NOT BE LESS THAN 125 PSI.

THE CONTRACTOR MAY INSTALL AND UTILIZE FILL/VENT PIPE(S) TO FILL THE WATER TUNNEL. THE CONTRACTOR IS RESPONSIBLE FOR OBTAINING THE EXISTING TUNNEL INVERTS. THE CONTRACTOR SHALL ENSURE THE FILL/VENT PIPE(S) ARE SPACED SUCH THAT THE CLSM OR GROUT IS EQUALLY DISTRIBUTED BY GRAVITY FLOW WITHIN THE WATER TUNNEL.

BACKFILL THE BALANCE OF THE DRILLED SHAFTS WITH SAND, A MINIMUM OF 72-HOURS AFTER THE PLACEMENT OF THE GROUT OR CLSM.

**SCHEDULE OF QUANTITIES**

	LOCATE TUNNEL	BULKHEAD TUNNEL	BULKHEAD TUNNEL (SPECIAL)	CONTROLLED LOW STRENGTH MATERIAL (SPECIAL)
	L SUM	L SUM	L SUM	CU YD
LOCATION 1 (VAN BUREN ST)	0.2	0.29	0	994.5
LOCATION 2 (HALSTED ST)	0.2	0.29	0	979.2
LOCATION 3 (HARRISON STREET)	0.6	0.42	1	1097.8
<b>TOTAL</b>	<b>1</b>	<b>1</b>	<b>1</b>	<b>3071.5</b>

HOT-MIX ASPHALT MIXTURE REQUIREMENTS MIXTURE TYPE	AIR VOIDS @ Ndes
PATCHING	
HMA REPLACEMENT OVER PATCHES (HMA BINDER IL-19 mm) (2-1/4" MIN.)	4% @ 70 GYR.

THE UNIT WEIGHT USED TO CALCULATE ALL HOT-MIX ASPHALT SURFACE MIXTURES IS 112 LBS/SQ YD / IN.

THE "AC TYPE" FOR ALL POLYMERIZED HMA MIXES SHALL BE SBS/SBR PG 76-22" AND FOR NON-POLYMERIZED HMA THE "AC TYPE" SHALL BE "PG 64-22" UNLESS MODIFIED BY THE DISTRICT ONE SPECIAL PROVISIONS.

FOR USE OF RECYCLED MATERIAL, SEE SPECIAL PROVISIONS.

FILE NAME = 8FILES

**COLLINS ENGINEERS**

USER NAME = rge11  
 PLOT SCALE = 100.0000' / 1" =  
 PLOT DATE = 4/12/2013

DESIGNED -  
 DRAWN -  
 CHECKED -  
 DATE -

REVISED -  
 REVISED -  
 REVISED -  
 REVISED -

**STATE OF ILLINOIS**  
**DEPARTMENT OF TRANSPORTATION**

**TUNNEL DETAILS AND NOTES**

SCALE: SHEET NO. OF SHEETS STA. TO STA.

F.A.I. RTE.	SECTION	COUNTY	TOTAL SHEETS	SHEET NO.
90/94	0101.6-2P-1-3 (13)	COOK	37	12
CONTRACT NO. 60W36			FED. ROAD DIST. NO. 1 ILLINOIS FED. AID PROJECT	