

- NOTES:**
1. CRACKS TO BE REPAIRED SHALL BE DESIGNATED BY THE RESIDENT ENGINEER. GENERAL DIRECTION SHALL BE TO REPAIR BY THIS METHOD ANY CRACKS GREATER THAN ONE (1") INCH IN WIDTH THAT REMAIN AFTER MILLING.
 2. THE DEPTH FOR ADDITIONAL REMOVAL MAY INCREASE AT THE DESIGNATION OF THE RESIDENT ENGINEER BASED ON THE SEVERITY OF THE CRACK. MINIMUM DEPTH OF THIS ADDITIONAL REMOVAL SHALL BE THREE (3") INCHES.
 3. THE CONTRACTOR SHALL REMOVE ALL LOOSE DEBRIS FROM THE EXTRA DEPTH REMOVAL TO THE SATISFACTION OF THE RESIDENT ENGINEER PRIOR TO APPLYING TACK COAT.
 4. PARALLEL CRACKS LOCATED LESS THAN THREE (3) FEET APART SHALL BE CONSIDERED ONE (1) CRACK FOR MEASUREMENT.

BITUMINOUS CRACK REPAIR (AR201660)
 N.T.S.

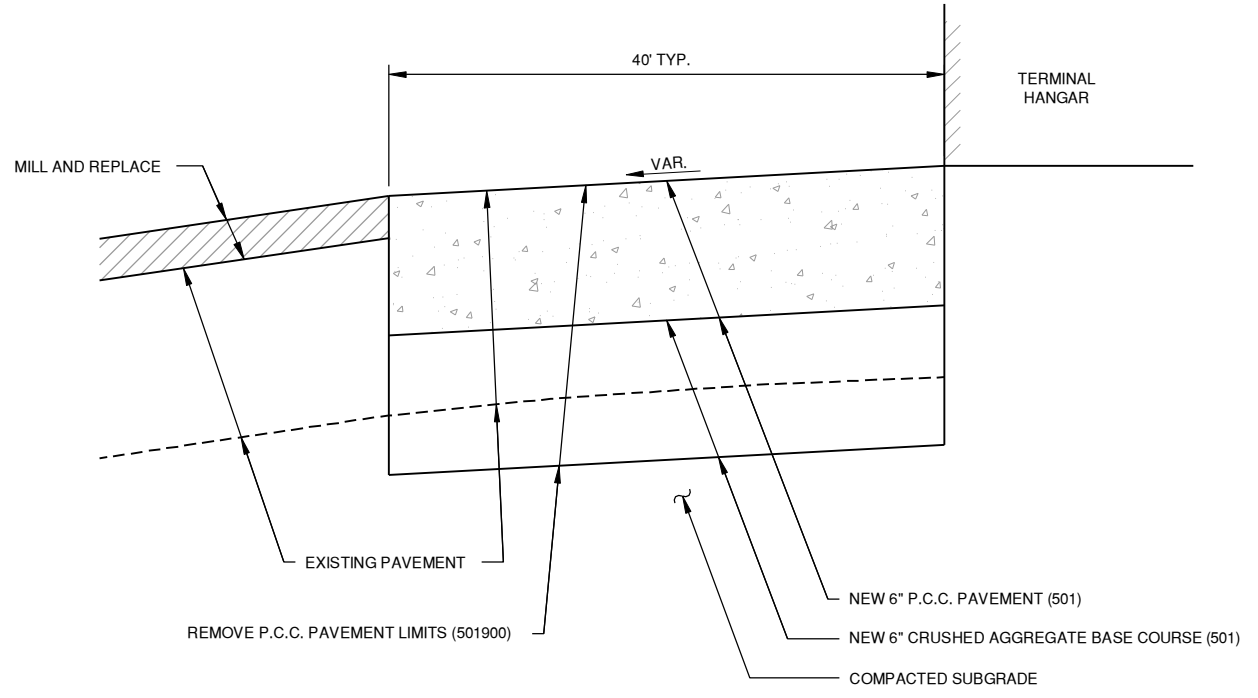

**SECTION C - TYPICAL SECTIONS
 P.C.C. APRON AT TERMINAL BUILDING**
 N.T.S.

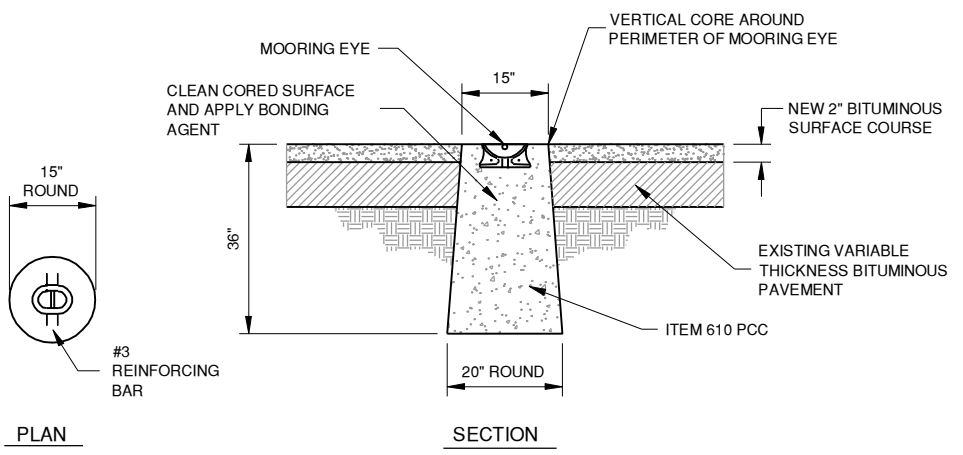

MOORING EYE IN PAVEMENT DETAIL
 N.T.S.

- MOORING NOTES**
1. MOORING CASTINGS SHALL BE NEENAH SEMI-STEEL AIRPORT MOORING EYE CATALOG NO. R3490 OR APPROVED EQUIVALENT.
 2. ANCHOR RODS SHALL BE #3 DEFORMED REBAR, 15" LONG AND SHALL BE BENT DOWNWARD AT 45 DEGREES.
 3. THE MOORING EYE SHALL BE INSTALLED AFTER PAVING OPERATIONS ARE COMPLETE BY CORING THROUGH NEW PAVEMENT.

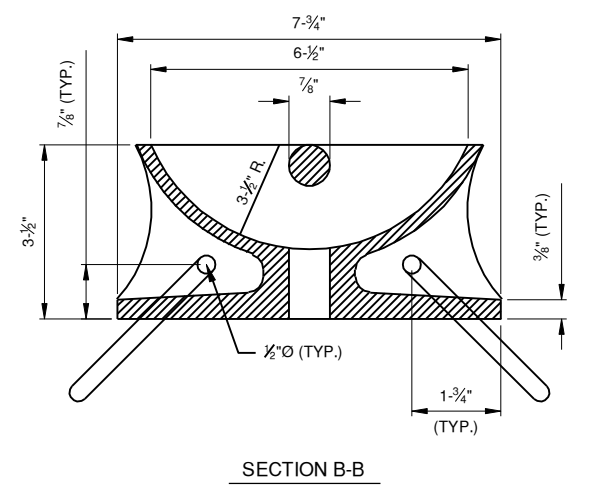

SECTION B-B

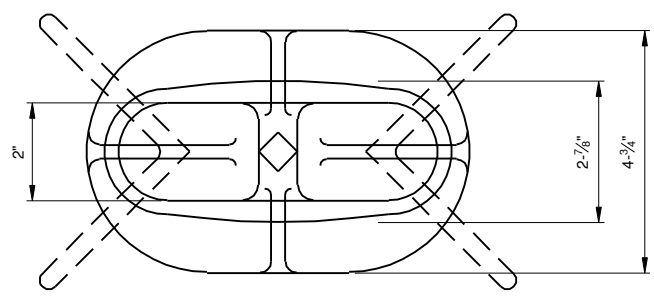

MOORING EYE DETAILS
 N.T.S.

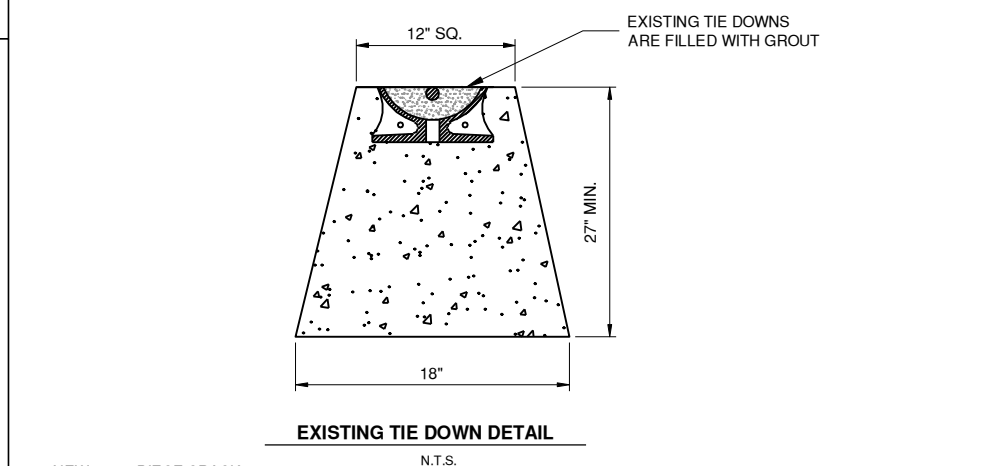

EXISTING TIE DOWN DETAIL
 N.T.S.

NEW 4' x 4' PIECE CRACK CONTROL FABRIC (AR201672) OVER TIEDOWN REMOVALS - TO BE PAID FOR UNDER ITEM AR201672 CRACK CONTROL FABRIC

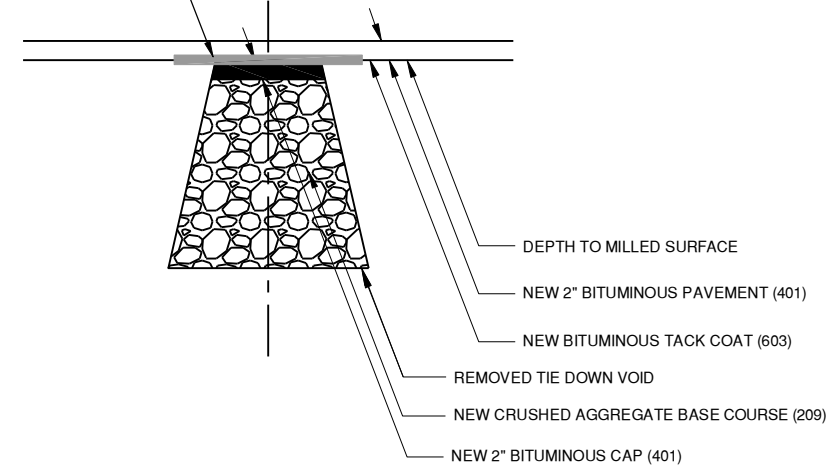

TIE DOWN BACKFILL DETAIL
 N.T.S.

TA006

REVISIONS		
NUMBER	BY	DATE

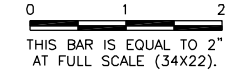

TAYLORVILLE MUNICIPAL AIRPORT
TAYLORVILLE, ILLINOIS
REHABILITATE NORTH PORTION OF AIRCRAFT PARKING APRON
MISCELLANEOUS DETAILS 1

© Copyright CMT, Inc.
CMT
 CRAWFORD, MURPHY & TULLY, INC.
 CONSULTING ENGINEERS
 License No. 184-000618

DESIGN BY:	AJH
DRAWN BY:	CMT
CHECKED BY:	CBG
APPROVED BY:	CET
DATE:	APRIL 18, 2014
JOB No:	13050-01
IL PROJ. NO. TAZ-4342	
SBG NO. 3-17-SBGP-XX	
SHEET 11 OF 14 SHEETS	