

**SECTION THRU EXPANSION JOINT AT ABUTMENT A**

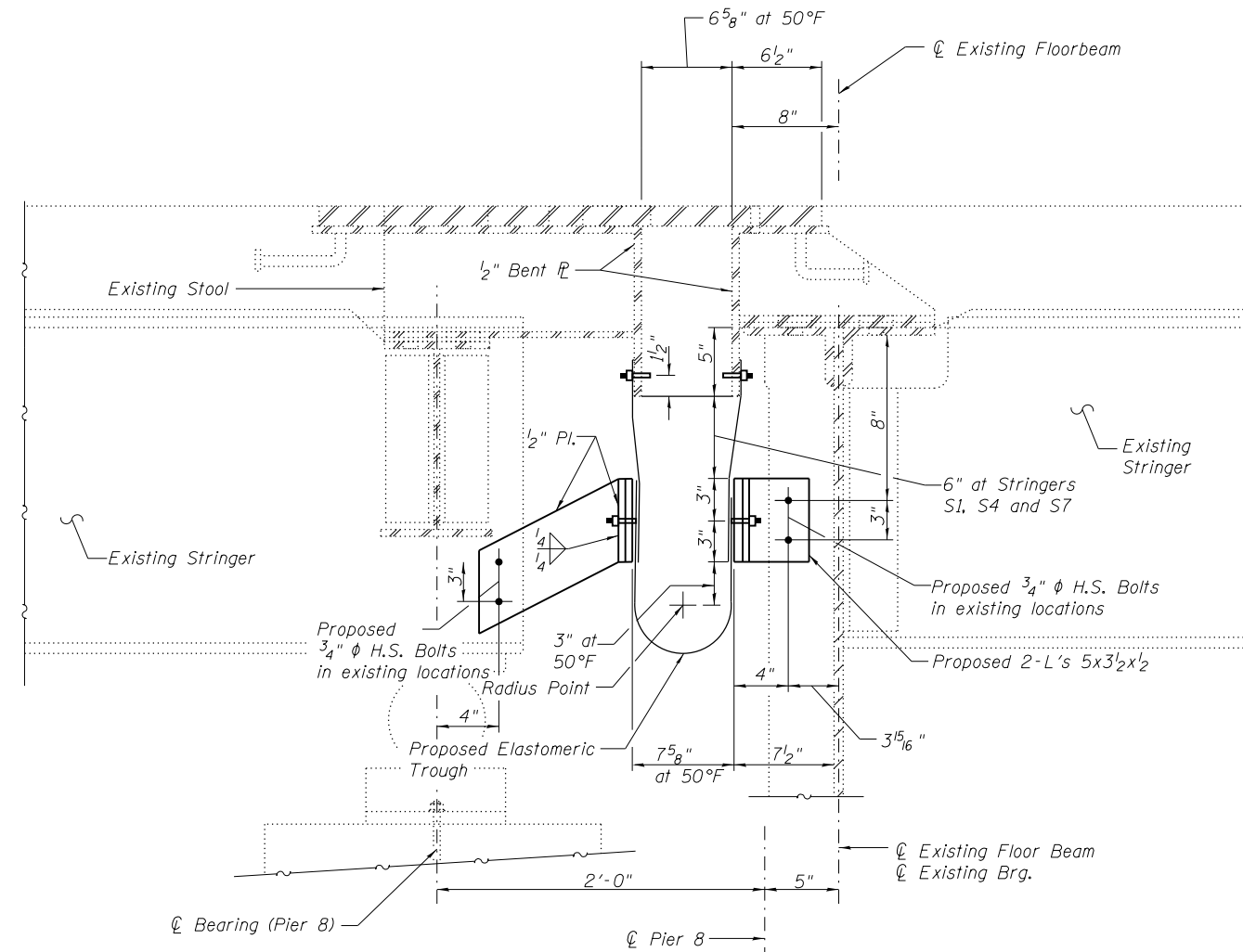

**SECTION THRU EXPANSION JOINT AT PIER 8**

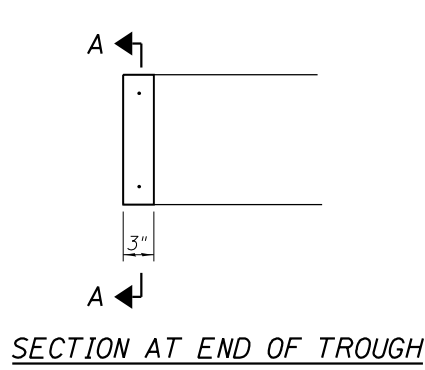

**SECTION AT END OF TROUGH**

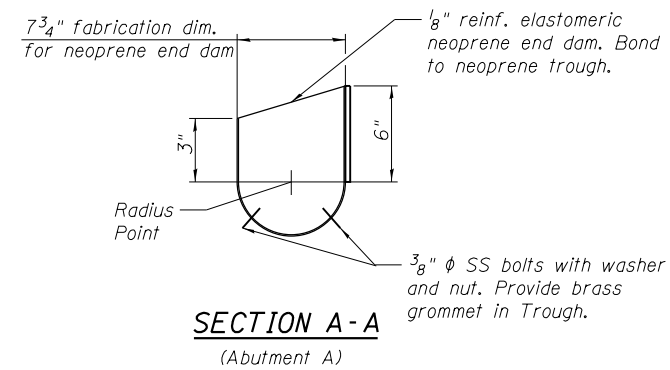

**SECTION A-A (Abutment A)**

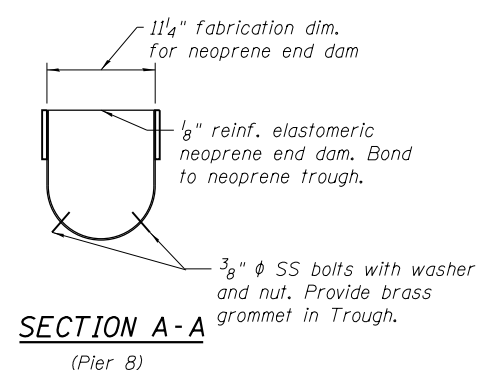

**SECTION A-A (Pier 8)**

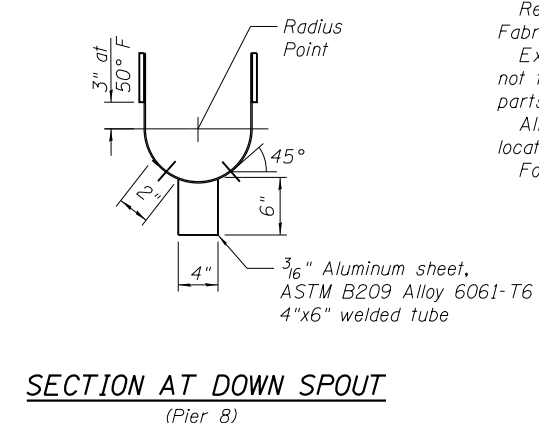

**SECTION AT DOWN SPOUT (Pier 8)**

**Notes:**  
 All connections and fasteners required to complete the work shall be included with the pay item Fabric Reinforced Elastomeric Trough. Removal of existing trough shall be included with the pay item, Fabric Reinforced Elastomeric Trough.  
 Extreme care shall be taken while replacing existing trough as not to damage any part of the existing joint assembly. Any damaged parts shall be replaced at Contractor's expense.  
 All the bolts required to connect the elastomeric trough shall be located in existing holes.  
 For elevation view of the trough, see sheet S099 of S138.

**BILL OF MATERIAL**

ITEM	UNIT	TOTAL
Fabric Reinforced Elastomeric Trough	Foot	85

(Sheet 2 of 2)