

WILLIAMSVILLE

STA. 322+67.62 TO STA. 327+67.62

NOTES

1. MILL TO BARE CONCRETE.
2. MATCH EXISTING SUPERELEVATION

LEGEND

- ① EXISTING CRCP PAVEMENT 9"
- ② EXISTING HOT-MIX ASPHALT 3 1/4"
- ③ EXISTING HOT-MIX ASPHALT 3"
- ④ EXISTING LONGITUDINAL JOINT
- ⑤ EXISTING STABILIZED SUBBASE 4"
- ⑥ EXISTING UNDERDRAIN
- ⑦ EXISTING HOT-MIX ASPHALT SHOULDER
- ⑧ PROPOSED POLYMERIZED HOT-MIX ASPHALT LEVELING BINDER COURSE, IL-9.5, N90, 1 1/2"
- ⑨ PROPOSED POLYMERIZED HOT-MIX ASPHALT SURFACE COURSE, MIX "D", N90, 1 1/2"
- ⑩ PROPOSED HOT-MIX ASPHALT SURFACE REMOVAL, (VARIABLE DEPTH)
- ⑪ PROPOSED MODIFIED URETHANE PAVEMENT MARKING - LINE, 5"
- ⑫ PROPOSED PREFORMED PLASTIC PAVEMENT MARKING TYPE B - INLAID - LINE, 5"

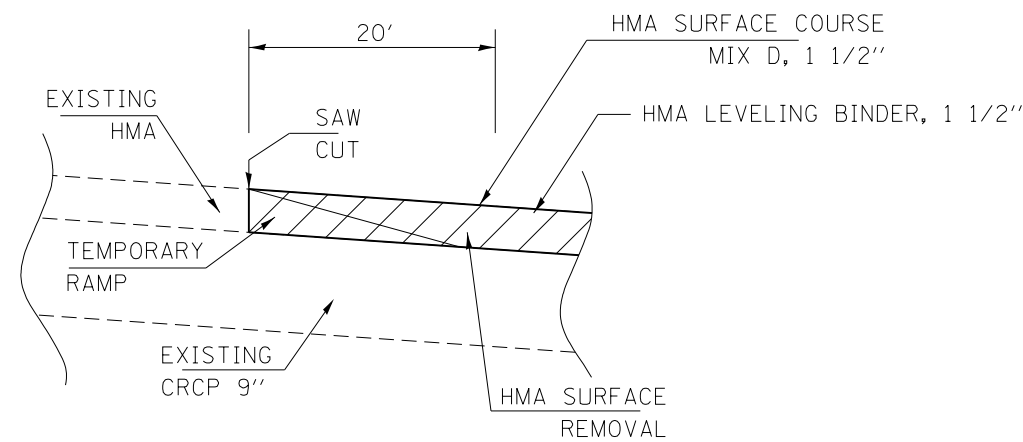

BUTT JOINT DETAIL

• D6 SPRING RD REPAIR 2014-2
 •• LOGAN/SANGAMON COUNTIES

FILE NAME =	USER NAME = sparksgw	DESIGNED -	REVISED -
ei:\pw\work\p\id\dot\sparksgw\10387600\0672\PH02-sht-typical.dgn		DRAWN -	REVISED -
Default	PLOT SCALE = 100.0000' / 1in.	CHECKED -	REVISED -
	PLOT DATE = Apr-17-2014 02:19:24PM	DATE -	REVISED -

STATE OF ILLINOIS
 DEPARTMENT OF TRANSPORTATION

I-55 TYPICAL SECTIONS
 D6 SPRING RD REPAIR 2014-2

SCALE: SHEET OF SHEETS STA. TO STA.

F.A.I. RTE.	SECTION	COUNTY	TOTAL SHEETS	SHEET NO.
55	•	••	10	6
CONTRACT NO. 72H02				
ILLINOIS FED. AID PROJECT				