

PLAN VIEW  
APPROACH SLAB OR BRIDGE APPROACH SHOULDER  
 (STANDARD 609001 or 609006)

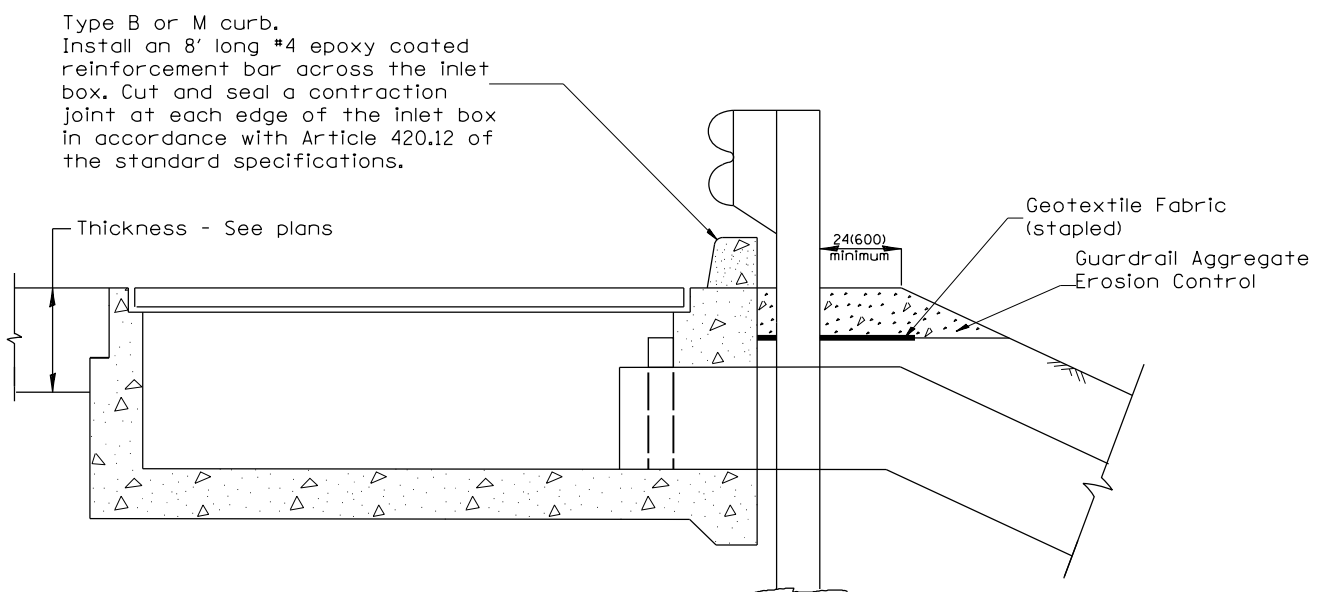

TYPICAL SECTION AT INLETS  
TYPE E & F (STANDARD 610001)

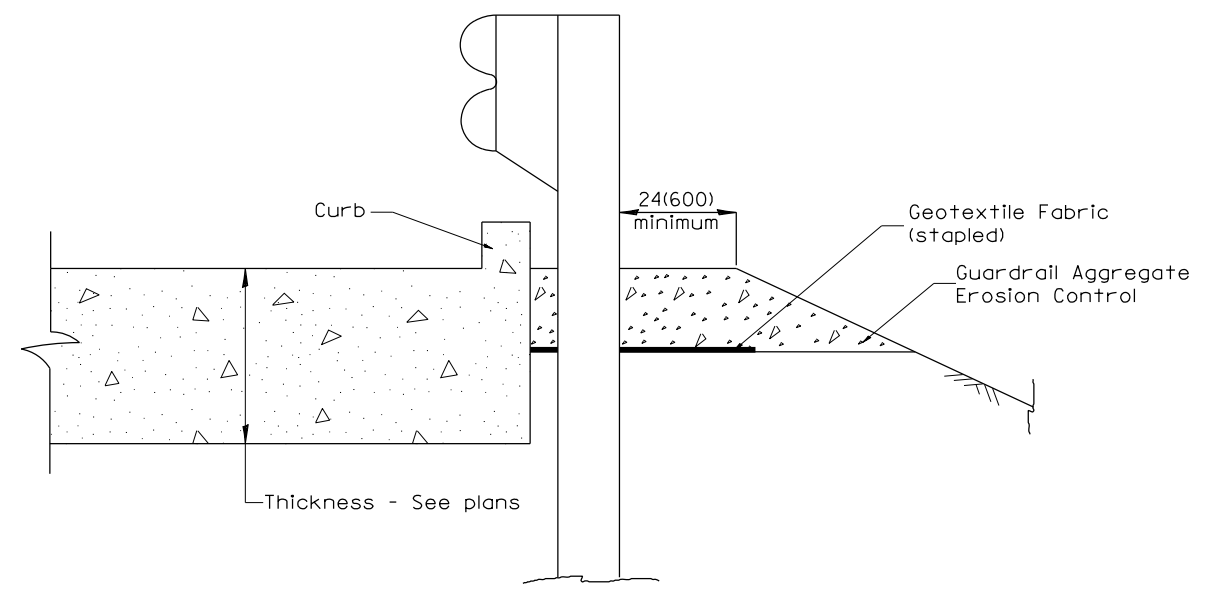

SECTION A-A  
TYPICAL SECTION WITH BRIDGE APPROACH CURB

All dimensions are in inches (millimeters) unless otherwise noted.

<b>STATE OF ILLINOIS</b> <b>DEPARTMENT OF TRANSPORTATION</b>	<b>GUARDRAIL EROSION CONTROL TREATMENTS</b>	SHT. 2 OF 2 CADD STD. 630101-D4	<table border="1" style="width: 100%; border-collapse: collapse;"> <tr> <th style="font-size: small;">F.A.U. RTE.</th> <th style="font-size: small;">SECTION</th> <th style="font-size: small;">COUNTY</th> <th style="font-size: small;">TOTAL SHEETS</th> <th style="font-size: small;">SHEET NO.</th> </tr> <tr> <td style="font-size: x-small;">6791</td> <td style="font-size: x-small;">126RS-4</td> <td style="font-size: x-small;">KNOX</td> <td style="font-size: x-small;">76</td> <td style="font-size: x-small;">76</td> </tr> <tr> <td colspan="5" style="text-align: center; font-size: x-small;">CONTRACT NO. 68B65</td> </tr> </table>	F.A.U. RTE.	SECTION	COUNTY	TOTAL SHEETS	SHEET NO.	6791	126RS-4	KNOX	76	76	CONTRACT NO. 68B65				
F.A.U. RTE.	SECTION	COUNTY	TOTAL SHEETS	SHEET NO.														
6791	126RS-4	KNOX	76	76														
CONTRACT NO. 68B65																		
			FED. ROAD DIST. NO. ILLINOIS FED. AID PROJECT															