















Pre-Stage 1a

Close WB I-74 entrance ramp from Eaton St./ Northeast Washington St. Utilizing the following:

ALL GROUND BASED SIGNS SHALL BE POST OR STAND MOUNTED.

- 1)  Place in grass median ~400' west of I-74 overpass. on Washington St.
- 2) Close turn lane leading to entrance ramp underneath I-74 overpass. Mono lit devices @ 20' cts. Start at concrete median on east side of signals.
- 3)  Place in the closed turn lane below the I-74 overpass.  

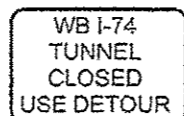
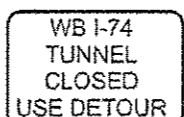
- 4)  Attach to green board sign in the southern shoulder under overpass of I-74. Cover white arrow and affix utilizing stainless steel bolts.
- 4) Cover "EAST" placard on existing I-74 signs along Eaton St. two locations.
- 5)  Place in the island at the intersection with Adams St.  

- 6)  Place on north shoulder of Jefferson St.  

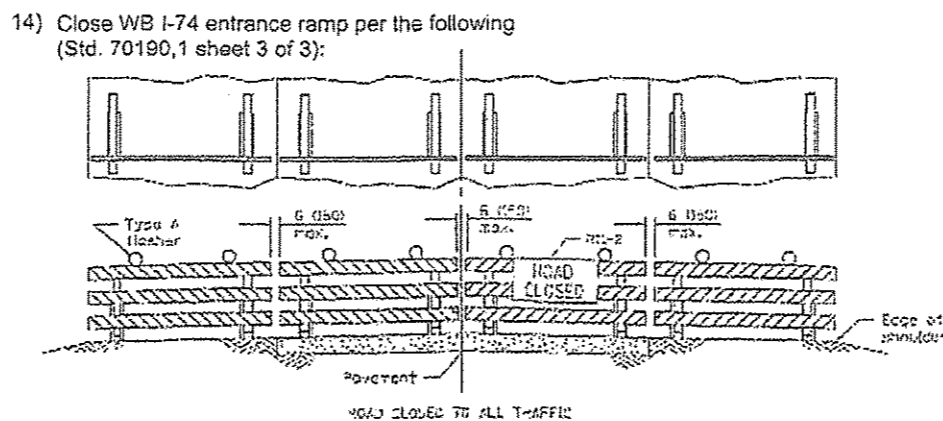
- 7)  Place one set on both sides of Spalding Ave. midway between Jefferson & I-74 entrance ramp.  

- 8)  Place on I-74 entrance ramp immediately adjacent to sign truss on shoulder.









- 9)  Cover existing vertical arrow on light pole located in the southwest corner of Fayette & Adams St. Affix utilizing stainless steel bolts.
- 10)  Cover existing vertical arrow on signal mast arm located on Adams St. Affix utilizing stainless steel bolts.
- 11)  Place inside lane closure of Adams St. over I-74 near intersection with Spalding Ave.  

- 12)  Place behind lane closure on Adams St. bridge.
- 13)  Place on Jefferson St. prior to intersection with Bryan Ave. Two signs.

- 15) Cover yellow warning merge sign on WB I-74 adjacent to ramp on shoulder.
- 16) Place 100' of bi-directional lighted devices at 20 cts. where the tunnel enters WB I-74.



ReflectORIZED striping may be omitted on the back side of the barricades. If a Type III barricade with an attached sign panel which meets NCHRP 350 is not available, the sign may be mounted on an NCHRP 350 temporary sign support directly in front of the barricade.

SIGN INVENTORY

SIGN	DESCRIPTION	TOTAL
	W20-2 48X48	1
	M1-9 (R) 30 X 24	1
	M4-9 (L) 30 X 24	1
	30 X 24	6
	M4-8a 24 X 18	1
	M3-4 24 X 12 BLACK ON WHITE	6
	24 X 18 BLACK ON WHITE	6
	48 X 48 BLACK ON ORANGE	3
	R11-2 48 X 30	1

S:\CEN\DRAWING\STANDARD\BRIDGE\CONTRACTS\DAYTON\ADAMS-ST-94-00-14-SN012-0179-0182.dgn