

SIDE ELEVATION
(Showing safety chain w/o sign)

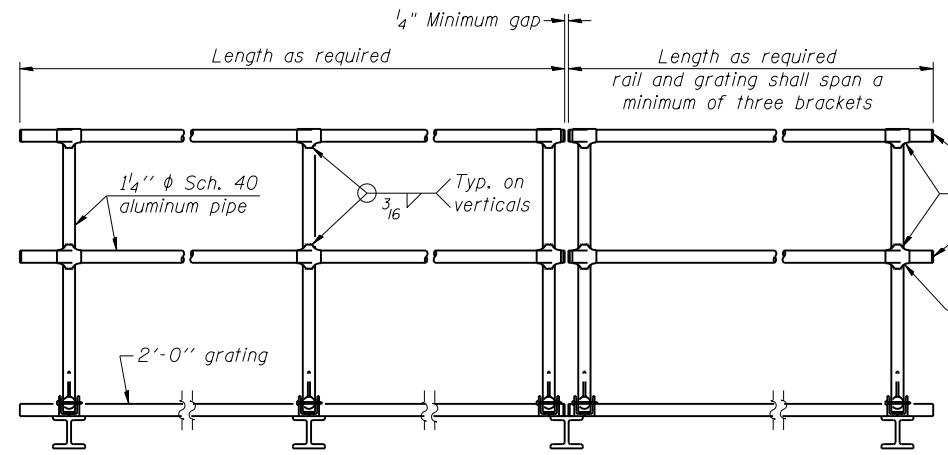

FRONT ELEVATION

HANDRAIL DETAILS

Handrail pipe shall be ASTM B241 or B429, Alloy 6063-T6 or Alloy 6061-T6.

- ① Install standard force-fit end caps or weld 3/8" end plates with 3/8" c.f.w. and grind smooth. (All rail ends)
- ② Horizontal handrail member shall be continuous thru fitting. Provide 7/16" hole in fitting for 3/8" bolt. Field drill 7/16" hole in horizontal rail member. Provide locknut and two stainless steel washers for bolt. (Use 5/16" eyebolts in 7/16" holes on top rail at ends only.)

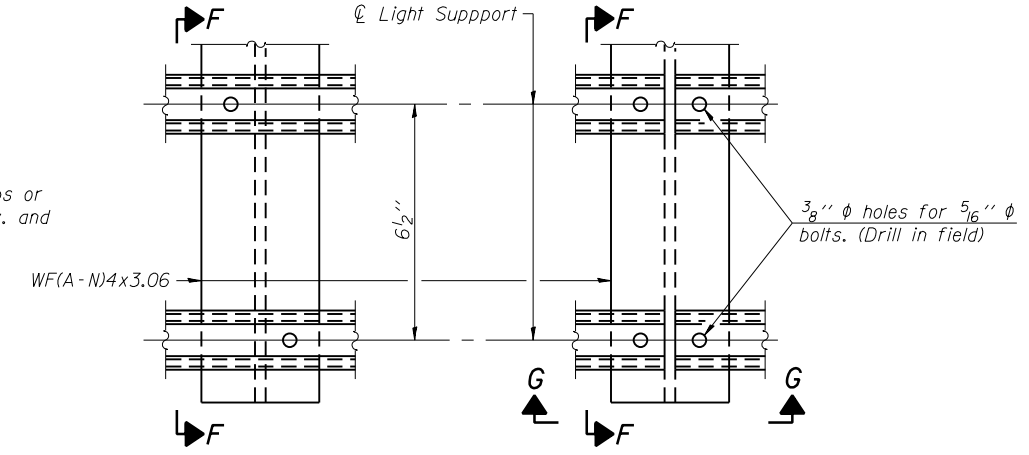

DETAIL F

DETAIL G

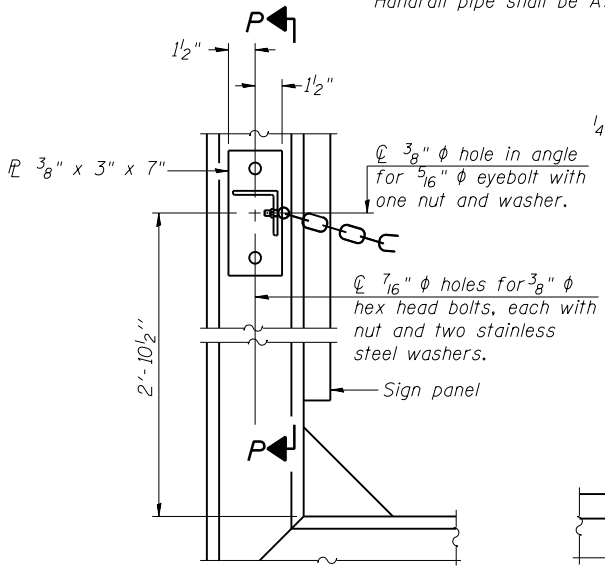

ALTERNATE SAFETY CHAIN ATTACHMENT

(With Sign Present)
Items not shown same as "Side Elevation" of "Handrail Details"

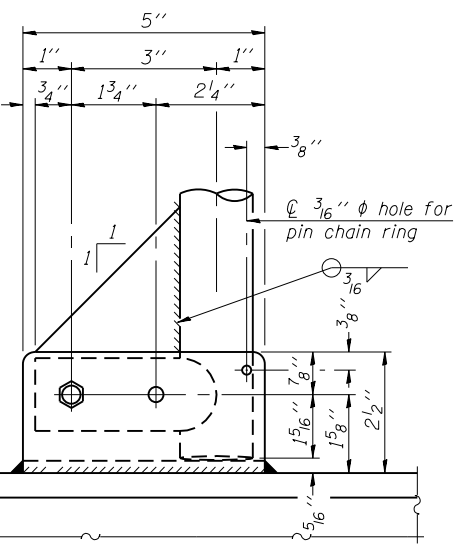

SIDE ELEVATION

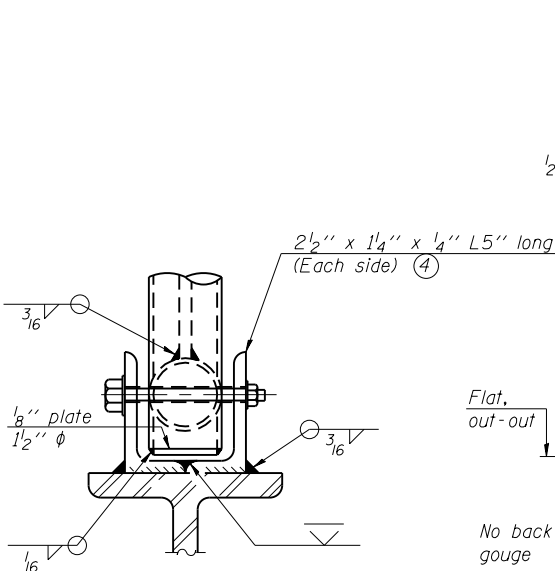

FRONT ELEVATION

See "Elevation" at right for dimensions.

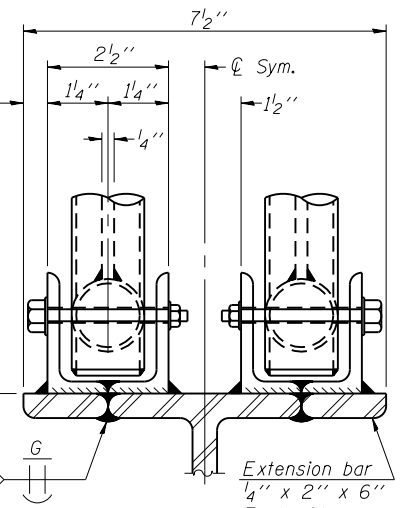

ELEVATION AT HANDRAIL JOINT

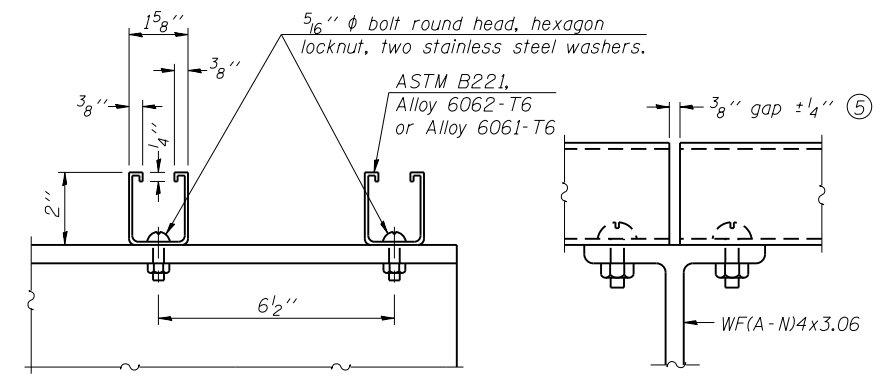

SECTION F-F

SECTION G-G

LIGHTING FIXTURE MOUNTS (IF REQUIRED)

- ⑤ Field cut ends of light support channels shall be free of burrs or hazardous projections and coated with zinc-rich primer or equivalent.

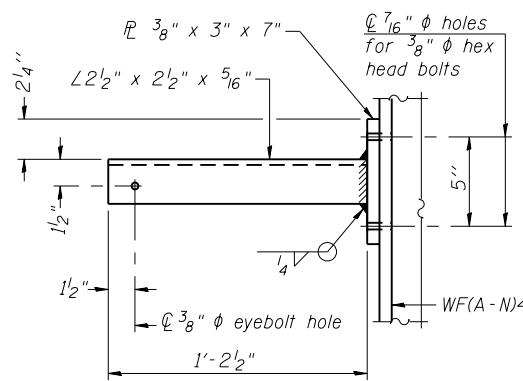

SECTION P-P

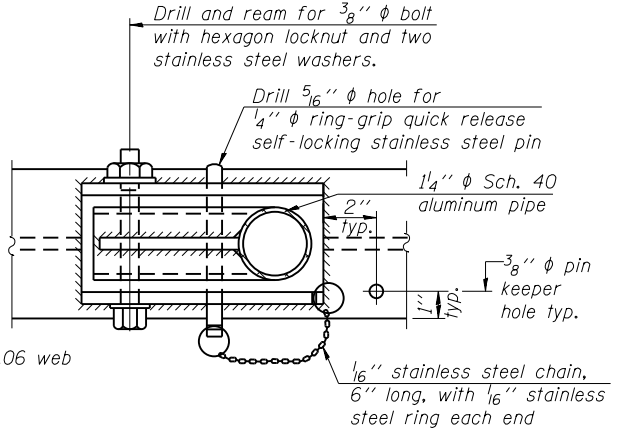

PLAN DETAIL E HANDRAIL HINGE

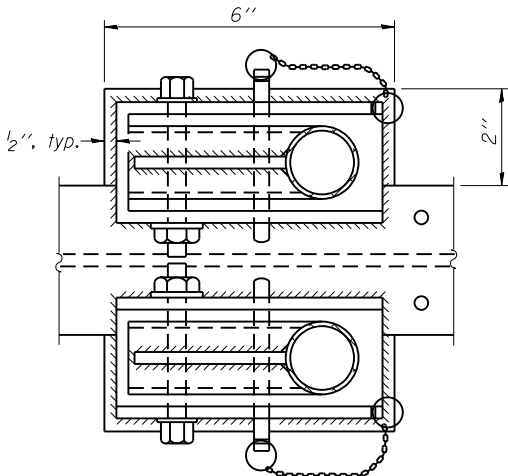

PLAN AT HANDRAIL JOINT

Details not shown same as "PLAN"

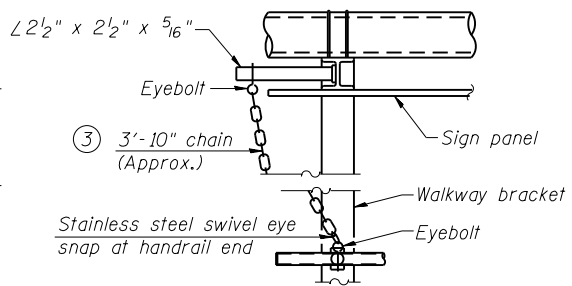

ALTERNATE SAFETY CHAIN ATTACHMENT

Details not shown similar to "Safety Chain" Details (Walkway omitted for clarity)

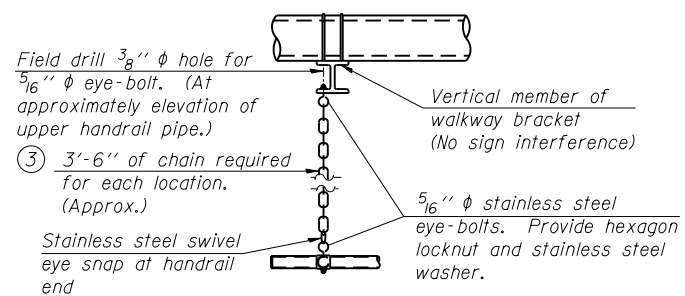

SAFETY CHAIN

One required for each end of each walkway.

- ③ 3/16" Type 304L stainless steel chain, approximately 12 links per foot.
- ④ Extrusions may be used in lieu of the details shown, with approval of the Engineer.

N:\PROJECTS\00200801\Design\Structural\CAD\SN-03-CN_-S020.dgn

OS-A-11

6-1-12



USER NAME = jattanaseo	DESIGNED - NG	REVISED -
PLOT SCALE = 0:2.0000 1' = 1/4"	CHECKED - BWS	REVISED -
PLOT DATE = 1/31/2014	DRAWN - RD	REVISED -
	CHECKED - BWS	REVISED -

DESIGNED - NG	REVISED -
CHECKED - BWS	REVISED -
DRAWN - RD	REVISED -
CHECKED - BWS	REVISED -

STATE OF ILLINOIS
DEPARTMENT OF TRANSPORTATION

OVERHEAD SIGN STRUCTURES
ALUMINUM HANDRAIL DETAILS

SHEET NO. S-20 OF S-26 SHEETS

F.A.I. RTE.	SECTION	COUNTY	TOTAL SHEETS	SHEET NO.
VAR.	.	..	45	39
D-2 OVD SIN STR REPL 14-27			CONTRACT NO. 46288	
ILLINOIS FED. AID PROJECT				

WINNEBAGO & OGLE