

CONSTRUCTION PLANS

FOR

SOUTHERN ILLINOIS AIRPORT AUTHORITY

MURPHYSBORO/CARBONDALE, JACKSON COUNTY, ILLINOIS

REHABILITATE TAXIWAY "B"

PAINT ENHANCED TAXIWAY CENTERLINE MARKINGS

SCOPE OF WORK

THIS PROJECT CONSISTS OF BITUMINOUS OVERLAY OF TAXIWAY "B". ASSOCIATED WORK WILL INCLUDE CLEANING AND SEALING CRACKS, BITUMINOUS CRACK REPAIR, MARKING, ENHANCED MARKING, SURFACE PAINTED HOLD POSITION SIGNS AND PAVEMENT MILLING.

SOUTHERN ILLINOIS AIRPORT

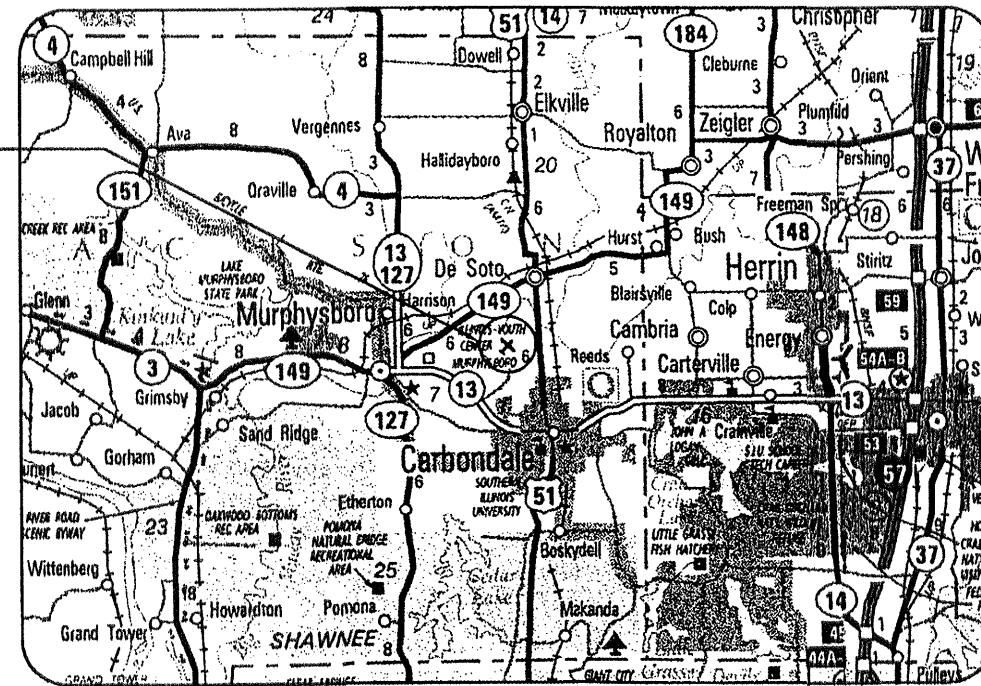

LOCATION

ILL. PROJ.: MDH-3892
 A.I.P. PROJ.: 3-17-0009-B29
 LATITUDE: 37° 46' 43"
 LONGITUDE: 89° 15' 08"
 ELEVATION: 411.0' M.S.L.
 DATE: APRIL 10, 2009

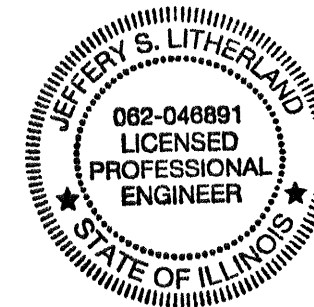

HANSON
Hanson Professional Services Inc.

Submitted by: *Jeffery S. Litherland* ENG'R
 Date Submitted: *May 11, 2009*
 Lics. Exp. Date: *Nov 30, 2009*

SOUTHERN ILLINOIS AIRPORT
AUTHORITY

Approved: *Carl E. Stinson* CHAIRMAN
 Date: *May 11, 2009*

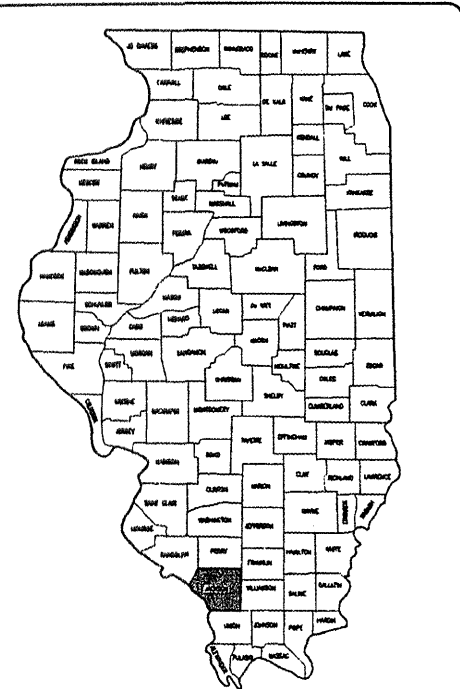

LOCATION OF COUNTY

| REVISION | DATE | BY |
|----------|------|----|
| | | |
| | | |
| | | |
| | | |
| | | |
| | | |
| | | |
| | | |
| | | |
| | | |

SOUTHERN ILLINOIS AIRPORT
MURPHYSBORO / CARBONDALE, ILLINOIS

SIA
SOUTHERN ILLINOIS AIRPORT

A.I.P. PROJ.: 3-17-0009-B29
IL PROJ.: MDH-3892

| | | | |
|----------------------------------|-------|----------|-----|
| Hanson Project No. 08A0067D.0800 | FILED | DATE | BY |
| R-001101R.DWG | NOT | 01/26/09 | JSL |
| Scale | SCALE | 04/05/09 | BAK |
| | | 07/26/09 | CAH |
| | | 04/19/09 | |

HANSON
Hanson Professional Services Inc.
1000 South Main Street
Springfield, Illinois 62703-2886
Office: 217-223-2886

REHABILITATE
TAXIWAY "B"
COVER SHEET

SCOPE OF WORK

THIS PROJECT CONSISTS OF BITUMINOUS OVERLAY OF TAXIWAY "B". ASSOCIATED WORK WILL INCLUDE CLEANING AND SEALING CRACKS, BITUMINOUS CRACK REPAIR, MARKING, ENHANCED MARKING, SURFACE PAINTED HOLD POSITION SIGNS AND PAVEMENT MILLING.

AIRPORT SECURITY NOTE

AIRPORT SECURITY WILL BE MAINTAINED AT ALL TIMES. THE CONTRACTOR WILL CLOSE AND LOCK THE EXISTING GATE IN THE HAUL ROUTE AT THE END OF EACH WORKING DAY.

UTILITY NOTE

THE CONTRACTOR SHALL CONTACT ALL UTILITY COMPANIES AND AGENCIES WHICH HAVE LINES OR CONDUITS IN THE PROPOSED WORK AREA. ALL LINES AND CONDUITS SHALL BE LOCATED AND IDENTIFIED FOR DEPTH BEFORE ANY EXCAVATION BEGINS. THE CONTRACTOR WILL CALL J.U.L.I.E. (1-800-892-0123) TO ACCOMPLISH THE ABOVE. IT IS THE CONTRACTOR'S RESPONSIBILITY TO IDENTIFY ALL UNDERGROUND NON-JULIE UTILITIES LOCATED WITHIN THE PROPOSED CONSTRUCTION LIMITS. THESE UNDERGROUND IMPROVEMENTS WILL BE LOCATED AT THE CONTRACTOR'S OWN EXPENSE PRIOR TO THE START OF CONSTRUCTION ACTIVITIES.

HEIGHT OF CONSTRUCTION EQUIPMENT

THE MAXIMUM ANTICIPATED HEIGHT OF THE CONSTRUCTION EQUIPMENT WILL BE 25 FEET. THE TALLEST EQUIPMENT IS EXPECTED TO BE A SEMI-TRAILER TRUCK.

HAUL ROUTE AND VEHICLE PARKING

THE CONTRACTOR WILL USE THE DESIGNATED HAUL ROUTE AND PARKING AREA AS SHOWN ON THIS SHEET. THE PROPOSED PARKING AREA WILL BE 200' X 200'. THE CONTRACTOR WILL BE REQUIRED TO MAINTAIN THE PROPOSED HAUL ROUTE AND PARKING AREA THROUGHOUT THE COURSE OF THE PROJECT. ANY AREAS DAMAGED OUTSIDE OF THESE AREAS WILL BE REPAIRED BY THE CONTRACTOR AND AT THE CONTRACTOR'S OWN EXPENSE. AT THE CONCLUSION OF THE PROJECT THE CONTRACTOR WILL GRADE, FERTILIZE, SEED AND MULCH THE HAUL ROUTE AND PARKING AREA AS NEEDED TO RESTORE IT TO ITS ORIGINAL STATE. RESTORATION OF THE HAUL ROUTE AND PARKING AREA WILL BE CONSIDERED INCIDENTAL TO THE PROJECT AND NO ADDITIONAL COMPENSATION WILL BE ALLOWED.

CONTRACTOR RESPONSIBILITIES

THE CONTRACTOR'S EQUIPMENT PARKING AND STORAGE AREA WILL BE AS SHOWN ON THIS SHEET. THE CONTRACTOR'S EMPLOYEES WILL PARK THEIR VEHICLES IN THIS AREA. ONLY CONTRACTOR VEHICLES WILL BE ALLOWED OUTSIDE THIS AREA.

THE CONTRACTOR AND HIS EMPLOYEES WILL BE RESTRICTED TO THE WORK AREA AND ALL OTHER AREAS OF THE AIRPORT ARE "OFF LIMITS" TO THEM.

THE CONTRACTOR SHALL KEEP ONE RUNWAY OPEN AT ALL TIMES AND MAINTAIN CONTINUOUS TAXIWAY ACCESS TO ALL HANGARS AND ADMINISTRATIVE AREAS. TAXIWAY "A" SHALL REMAIN OPEN AT ALL TIMES.

ALL WORK PERFORMED SHALL BE DONE IN A ORDERLY AND EFFECTIVE MANNER TO MINIMIZE RUNWAY CLOSURE(S).





NO TRENCHES OR HOLES WILL REMAIN OPEN OVERNIGHT.

ONLY RUNWAY 6/24 SHALL BE CLOSED OVERNIGHT.

BARRICADES AND TRAFFIC CONES

IT WILL BE THE CONTRACTOR'S RESPONSIBILITY TO PLACE AND MAINTAIN BARRICADES AND TRAFFIC CONES AS DIRECTED BY THE AIRPORT MANAGER. THE BARRICADES WILL BE EQUIPPED WITH RED FLASHING OR RED STEADY-BURN LIGHTS AND 20" SQUARE ORANGE FLAGS. THE BARRICADES, THEIR MAINTENANCE, PLACEMENT AND REMOVAL WILL BE CONSIDERED AS AN INCIDENTAL ITEM TO THE CONTRACT AND NO ADDITIONAL COMPENSATION WILL BE ALLOWED.

LEGEND

-  EXISTING IMPROVEMENTS
-  PROPOSED IMPROVEMENTS
-  EXISTING BUILDINGS
-  PROPOSED HAUL ROUTE AND EQUIPMENT PARKING AREA

THE LOCATION, SIZE AND TYPE OF MATERIAL OF EXISTING UNDERGROUND UTILITIES INDICATED ON THE PLANS IS NOT REPRESENTED AS BEING ACCURATE, SUFFICIENT OR COMPLETE. IT SHALL BE THE CONTRACTOR'S RESPONSIBILITY TO DETERMINE THE ACTUAL LOCATION OF ALL SUCH FACILITIES, INCLUDING SERVICE CONNECTIONS TO UNDERGROUND UTILITIES. PRIOR TO CONSTRUCTION, THE CONTRACTOR SHALL NOTIFY THE UTILITY COMPANIES OF HIS OPERATIONAL PLANS AND SHALL OBTAIN FROM THE RESPECTIVE UTILITY COMPANIES DETAILED INFORMATION AND ASSISTANCE RELATIVE TO THE LOCATION OF THEIR FACILITIES AND THE WORKING SCHEDULE OF THE COMPANIES FOR REMOVAL OR ADJUSTMENT WHERE REQUIRED. IN THE EVENT AN UNEXPECTED UTILITY INTERFERENCE IS ENCOUNTERED DURING CONSTRUCTION, THE CONTRACTOR SHALL IMMEDIATELY NOTIFY THE UTILITY COMPANY OF JURISDICTION. THE ENGINEER SHALL ALSO BE IMMEDIATELY NOTIFIED. ANY SUCH MAINS AND SERVICES SHALL BE RESTORED TO SERVICE AT ONCE AND PAID FOR BY THE CONTRACTOR AT NO ADDITIONAL COST TO THE CONTRACT.

CALL J.U.L.I.E. FOR UTILITY INFORMATION AT 1-800-892-0123.

CERTIFIED PAYROLLS

THE RESIDENT ENGINEER CANNOT FORWARD CONSTRUCTION REPORTS TO THE ILLINOIS DIVISION OF AERONAUTICS FOR PROCESSING UNTIL ALL CERTIFIED PAYROLLS FOR THE PERIOD HAVE BEEN RECEIVED.

MATERIAL CERTIFICATION

COMPLETED WORK CANNOT BE PLACED ON A CONSTRUCTION REPORT UNTIL ALL MATERIAL CERTIFICATIONS FOR THAT PAY ITEM HAVE BEEN RECEIVED, REVIEWED AND ACCEPTED BY THE RESIDENT ENGINEER.

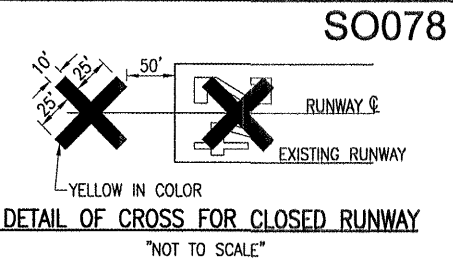
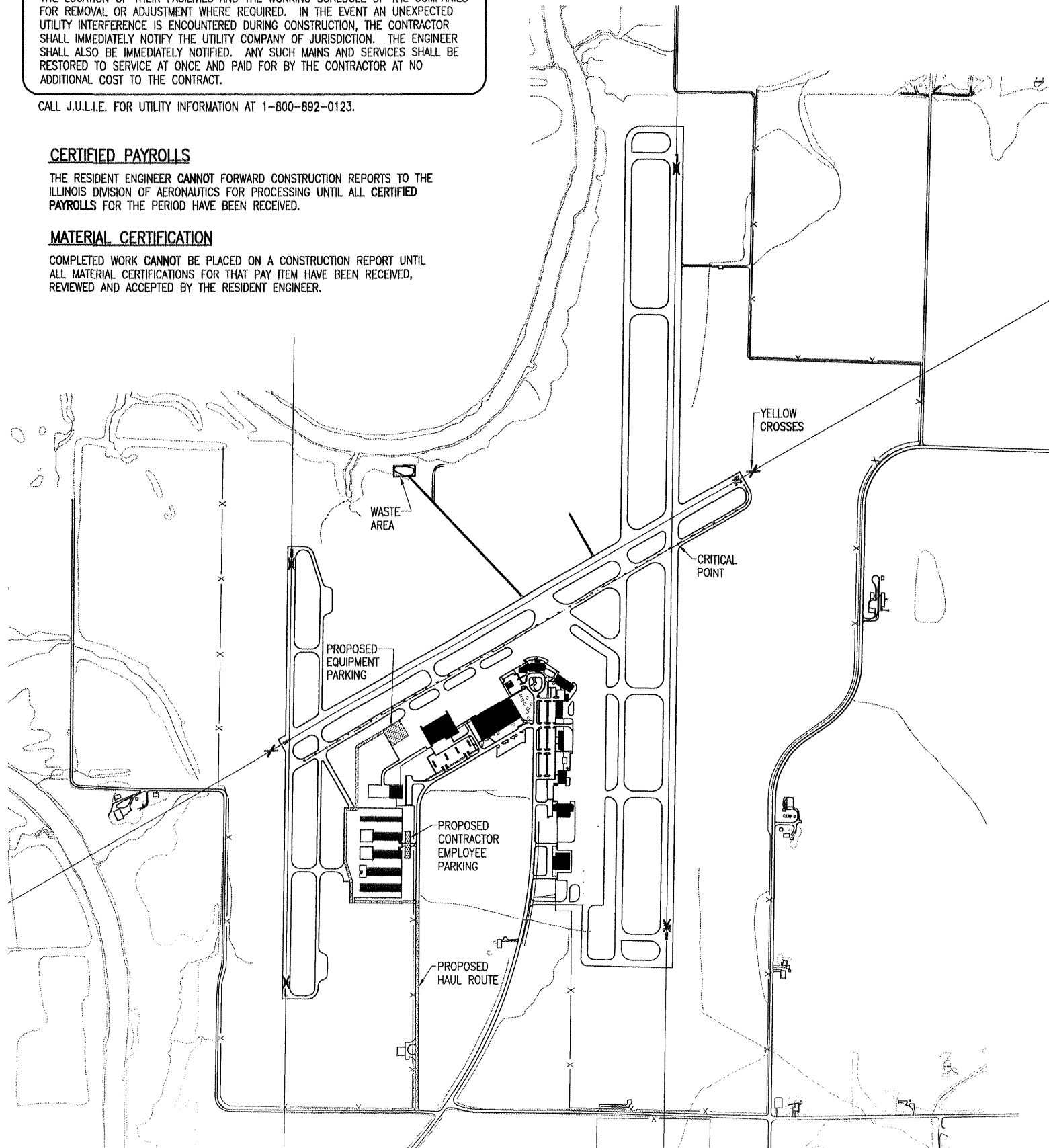

NOTE:

COST OF CONSTRUCTING, PLACING, MAINTAINING AND REMOVING CROSSES WILL BE CONSIDERED INCIDENTAL TO THE CONTRACT AND NO ADDITIONAL COMPENSATION WILL BE ALLOWED. THE CROSSES WILL BE YELLOW IN COLOR AND SHALL BE MADE OF A SUITABLE MATERIAL AS APPROVED BY THE AIRPORT MANAGER. THE CROSSES WILL BE PLACED OVER THE NUMERALS AND SECURED IN A MANNER APPROVED BY THE MANAGER. THE PROPOSED CROSSES WILL BE PLACED EACH DAY THE RUNWAY IS CLOSED AND REMOVED WHEN THE RUNWAY IS RE-OPENED. THE CONTRACTOR WILL BE RESPONSIBLE FOR THE PLACEMENT AND REMOVAL OF THE CROSSES. NO ADDITIONAL COMPENSATION WILL BE ALLOWED.

J.U.L.I.E. INFORMATION

COUNTY JACKSON
 CITY CARBONDALE
 TOWNSHIP 8 SOUTH
 RANGE 1 WEST
 SECTION NO. 31 & 32
 ADDRESS P.O. BOX 1086
 CARBONDALE, ILLINOIS 62903-1086

CRITICAL POINT DATA

LATITUDE: 37° 46' 47.24138"
 LONGITUDE: 89° 14' 53.62127"
 ELEVATION: 404.3 M.S.L.

PROPOSED SAFETY PLAN

GENERAL - THE SOUTHERN ILLINOIS AIRPORT IS COMPRISED OF THREE RUNWAYS. THE PROPOSED CONSTRUCTION WILL NECESSITATE CLOSING ALL RUNWAYS. ANY TIME THE CONTRACTOR IS WORKING WITHIN 250' OF THE RUNWAY CENTERLINE THE RUNWAY WILL BE CLOSED EXCEPT FOR RUNWAY 6/24. THE PARALLEL RUNWAYS WILL BE CLOSED ONLY DURING THE CONSTRUCTION DAY. AT THE END OF EACH CONSTRUCTION DAY THE CONTRACTOR WILL SMOOTH GRADE ALL AREAS WITHIN THE SAFETY AREA TO THE SATISFACTION OF THE RESIDENT ENGINEER AND RE-OPEN THE RUNWAY. ALL WORK INCLUDED IN OPENING AND CLOSING THE RUNWAY WILL BE CONSIDERED INCIDENTAL TO THE PROJECT AND NO ADDITIONAL COMPENSATION WILL BE ALLOWED.

IDENTIFICATION - WHEN THE CONTRACTORS VEHICLES AND EQUIPMENT ARE ON THE AIRPORT THEY SHALL BE PROPERLY MARKED WITH THREE (3') FOOT SQUARE CHECKERED FLAGS (INTERNATIONAL ORANGE AND WHITE). THE CONTRACTOR WILL ALSO PROVIDE WORKERS WITH SOME TYPE OF TAG OR GARMENT TO IDENTIFY THE PERSON AS BEING PART OF THE CONSTRUCTION CREW.



RADIO CONTROL - THE CONTRACTOR WILL BE REQUIRED TO BE IN TWO-WAY RADIO CONTACT (121.80 MHz.) WITH THE AIRPORT CONTROL TOWER. THIS WILL ENABLE THE AIRPORT TO IMMEDIATELY CONTACT THE CONTRACTOR IN CASE OF AN AERONAUTIC EMERGENCY THAT WOULD REQUIRE ACTION BY THE CONTRACTOR AND/OR HIS PERSONNEL.

THE CONTRACTOR SHALL BE REQUIRED TO RECIEVE FAR PART 139 TRAINING FOR ALL PERSONNEL WHO DRIVE VEHICLES INSIDE THE FENCED AREA OF THE AIRPORT. SEE SPECIAL PROVISIONS FOR ADDITIONAL INFORMATION.

EROSION CONTROL

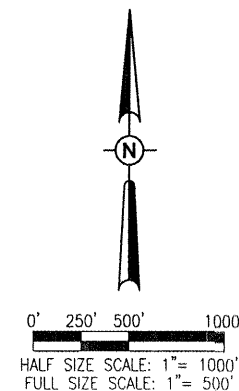
THIS PROJECT WILL DISTURB LESS THAN 1 ACRE OF LAND, THEREFORE NO N.P.D.E.S. PERMIT WILL BE REQUIRED.



| | | | | | |
|---|----|---|----------------------|--|--|
| REVISION | BY | | | | |
| DATE | | | | | |
|  | | | | | |
| SOUTHERN ILLINOIS AIRPORT MURPHYSBORO / CARBONDALE, ILLINOIS | | | | | |
| A.I.P. PROJ.: 3-17-0009-B29 | | | | | |
| IL PROJ.: MDH-3892 | | | | | |
| Hanson Project No. 08A0067D_0800 Name: R-0035FY.DWG Scale: 1" = 500' Date: 01/26/09 | | LAYOUT: JSL 04/03/09 DRAWN: BAK 01/26/09 REVIEWED: CAH 04/10/09 | | | |
|  | | | | | |
| Hanson Professional Services Inc. 1626 South Main Street Springfield, IL 62761-2886 Offices Nationwide | | | | | |
| REHABILITATE TAXIWAY "B" | | | PROPOSED SAFETY PLAN | | |
| 3 | | | | | |
| 3 of 27 sheets | | | | | |

MAY 12, 2009 11:14 AM KINCAD0394 \\A:\AIRPORTS\SIH-CARBONDALE\08A0067\CADD\AIRPORT\PROJECT\0035FY.DWG - Layout1

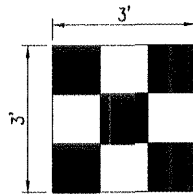

ORANGE AND WHITE
**CONSTRUCTION EQUIPMENT
 AND TRUCK SIGNAL FLAG**
 "NOT TO SCALE"

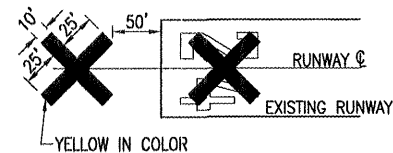

YELLOW IN COLOR
DETAIL OF CROSS FOR CLOSED RUNWAY
 "NOT TO SCALE"

NOTE:

COST OF CONSTRUCTING, PLACING, MAINTAINING AND REMOVING CROSSES WILL BE CONSIDERED INCIDENTAL TO THE CONTRACT AND NO ADDITIONAL COMPENSATION WILL BE ALLOWED. THE CROSSES WILL BE YELLOW IN COLOR AND SHALL BE MADE OF A SUITABLE MATERIAL AS APPROVED BY THE AIRPORT MANAGER. THE CROSSES WILL BE PLACED OVER THE NUMERALS AND SECURED IN A MANNER APPROVED BY THE MANAGER. THE PROPOSED CROSSES WILL BE PLACED EACH DAY THE RUNWAY IS CLOSED AND REMOVED WHEN THE RUNWAY IS RE-OPENED. THE CONTRACTOR WILL BE RESPONSIBLE FOR THE PLACEMENT AND REMOVAL OF THE CROSSES. NO ADDITIONAL COMPENSATION WILL BE ALLOWED.

CONTRACTOR'S ACCESS SHALL BE AS FOLLOWS:

- A. THE CONTRACTOR'S ACCESS TO THE WORK SHALL BE THROUGH THE WEST ACCESS GATE (2A), AS SHOWN. THE CONTRACTOR SHALL BE PROVIDED WITH TWO (2) ACCESS CARDS THAT WILL BE RETURNED TO THE AIRPORT PRIOR TO PROJECT ACCEPTANCE.
- B. THE ACCESS GATE SHALL REMAIN IN NORMAL OPERATING MODE DURING WORKHOURS. WHEN THE CONTRACTOR'S ACTIVITIES REQUIRE THE GATE TO BE HELD OPEN CONTINUOUSLY, HE SHALL POST A COMPETENT SECURITY GUARD TO PREVENT UNAUTHORIZED ENTRIES. THE CONTRACTOR SHALL REPLACE ANY UNSATISFACTORY SECURITY GUARDS IF SO DIRECTED BY THE RESIDENT ENGINEER.
- C. THE CONTRACTOR SHALL ENSURE THAT THE ELECTRIC ACCESS GATE IS CLOSED AND OPERATING PROPERLY PRIOR TO LEAVING THE SITE.
- D. ALL COSTS RELATING TO CONTRACTOR'S ACCESS AND SECURITY SHALL BE THE RESPONSIBILITY OF THE CONTRACTOR.
- E. THE CONTRACTOR SHALL STORE EQUIPMENT AND MATERIALS IN DESIGNATED AREAS AND IN SUCH A WAY AS NOT TO VIOLATE AIRPORT PART 77 SURFACES, OR RUNWAY AND TAXIWAY SAFETY.
- F. THE CONTRACTOR SHALL BE RESPONSIBLE FOR CLEANING ACTIVE AIRFIELD PAVEMENTS WHICH ARE CROSSED BY HIS VEHICLES ACCESSING THE WORK OR DEPARTING THE WORK IMMEDIATELY FOLLOWING SAID VEHICLE.
- G. UPON COMPLETION OF PROJECT, CONTRACTOR SHALL RESTORE THE LAYDOWN AREA TO PRE-CONSTRUCTION CONDITION AT NO ADDITIONAL EXPENSE TO THE PROJECT.

SEQUENCE OF CONSTRUCTION FOR PATCHING, CRACK FILLING AND PAVING SO078

- 1. CLOSE RUNWAY 6/24 BY PLACING YELLOW CROSSES AT BOTH ENDS OF THE RUNWAY. PLACE BARRICADES WHERE SHOWN.
- 2. PLACE FLAGGERS AT LOCATIONS SHOWN. TAXIWAY "A" FLAGGER REQUIRED WHEN CONTRACTOR IS WORKING EAST OF TAXIWAY "A". TAXIWAY "A" MUST REMAIN OPEN AT ALL TIMES.
- 3. CLOSE RUNWAY 18R/36L AND BEGIN PATCHING OPERATIONS. COMPLETE ANY PATCHING WITHIN THE SAFETY AREA OF RUNWAY 18R/36L PRIOR TO ANY OTHER PATCHING OR REMOVAL AND REPLACEMENT WORK. ONCE THE PATCHING WITHIN THE SAFETY AREA OF 18R/36L IS COMPLETE AND ALL DEBRIS, MEN AND EQUIPMENT HAVE BEEN REMOVED FROM THE RUNWAY SAFETY AREA, REOPEN RUNWAY 18R/36L. CONTINUE PATCHING AND FULL DEPTH REMOVAL AND REPLACEMENT ON TAXIWAY "B".
- 4. ONCE THE PATCHING OPERATIONS ARE COMPLETE AND THE CONTRACTOR IS READY TO BEGIN PAVEMENT MILLING OPERATIONS, CLOSE RUNWAY 18L/36R AND MILL THE PORTION OF TAXIWAY "B" EAST OF RUNWAY 18L/36R. ONCE THE MILLING IN THIS AREA IS COMPLETE, APPLY TACK COAT TO THIS AREA. ENSURE RUNWAY 18L/36R IS CLEAN AND REOPEN. CONTRACTOR HAS ONE DAY TO COMPLETE THE MILLING AND THE TACK COAT EAST OF RUNWAY 18L/36R. COORDINATE ANY SHORT DURATION CLOSING OF THE RUNWAY WITH THE AIRPORT CONTROL TOWER.
- 5. CLOSE RUNWAY 18R/36L. MILL TAXIWAY "B" WITHIN THE RUNWAY SAFETY AREA OF 18R/36L. ONCE THE MILLING IN THIS AREA IS COMPLETE, ENSURE RUNWAY 18R/36L IS CLEAN, REMOVE ALL MEN AND EQUIPMENT WITHIN THE RUNWAY SAFETY AREA, AND REOPEN RUNWAY 18R/36L. MILL THE REMAINDER OF TAXIWAY "B" AND TAXIWAY "F" WEST OF TAXIWAY "A". CONTRACTOR HAS 1/2 DAY (4 CONSECUTIVE HOURS) TO CLOSE RUNWAY 18R/36L FOR THIS OPERATION. CLEAN AND SEAL ALL CRACKS IDENTIFIED BY THE RESIDENT ENGINEER. APPLY TACK COAT TO THE REMAINDER OF TAXIWAY "B".
- 6. CLOSE RUNWAY 18L/36R FOR PAVING OPERATIONS WITHIN THE RUNWAY SAFETY AREA EAST OF THE RUNWAY. CONTRACTOR TO CLOSE THIS RUNWAY FOR A MAXIMUM OF 2 DAYS AND THE RUNWAY IS TO BE REOPENED AT THE END OF EACH DAY. COMPLETE ALL PAVING EAST OF RUNWAY 18L/36R BEFORE DOING ANY OTHER PAVING.
- 7. COMPLETE PAVING ON THE BALANCE OF TAXIWAY "B" & "F". CLOSE RUNWAY 18R/36L ONLY AS NEEDED. ONCE ALL PAVING IS COMPLETED, ALL PAVEMENTS HAVE BEEN CLEANED TO THE SATISFACTION OF THE AIRPORT MANAGER, AND ALL BARRICADES HAVE BEEN REMOVED, THEN REOPEN ALL TAXIWAYS AND RUNWAYS.

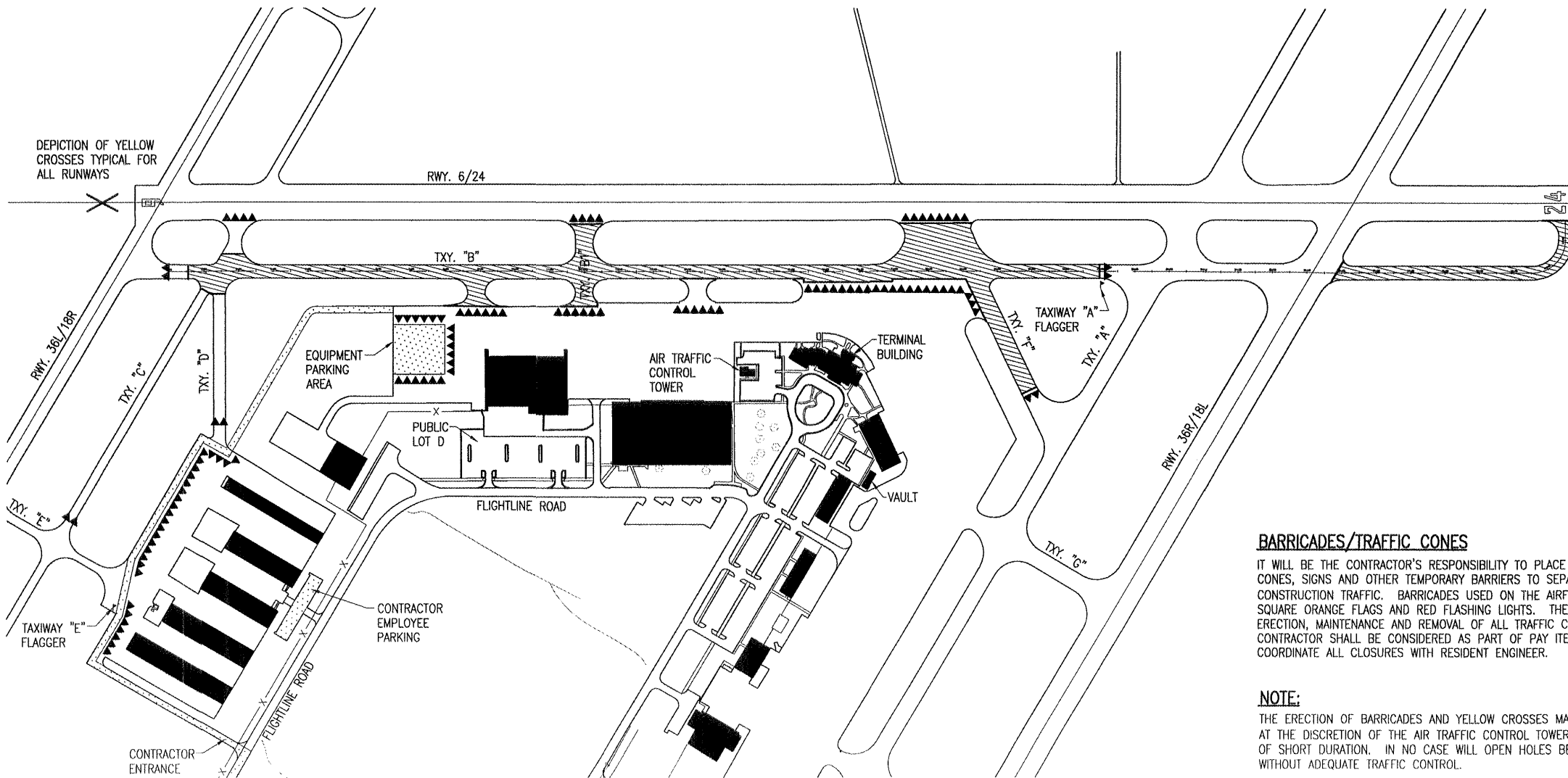

LEGEND

- EXISTING IMPROVEMENTS
- PROPOSED IMPROVEMENTS
- EXISTING BUILDINGS
- PROPOSED HAUL ROUTE AND EQUIPMENT PARKING
- PROPOSED BARRICADES/TRAFFIC CONES

BARRICADES/TRAFFIC CONES

IT WILL BE THE CONTRACTOR'S RESPONSIBILITY TO PLACE AND MAINTAIN BARRICADES, TRAFFIC CONES, SIGNS AND OTHER TEMPORARY BARRIERS TO SEPARATE AIRCRAFT TRAFFIC AND CONSTRUCTION TRAFFIC. BARRICADES USED ON THE AIRFIELD WILL BE EQUIPPED WITH 20" SQUARE ORANGE FLAGS AND RED FLASHING LIGHTS. THE RESPONSIBILITY OF AND COST OF ERECTION, MAINTENANCE AND REMOVAL OF ALL TRAFFIC CONTROL MEASURES USED BY THE CONTRACTOR SHALL BE CONSIDERED AS PART OF PAY ITEM AR150530 TRAFFIC MAINTENANCE. COORDINATE ALL CLOSURES WITH RESIDENT ENGINEER.

NOTE:

THE ERECTION OF BARRICADES AND YELLOW CROSSES MAY BE WAIVED FOR CERTAIN PHASES AT THE DISCRETION OF THE AIR TRAFFIC CONTROL TOWER (ATCT) MANAGER FOR OPERATIONS OF SHORT DURATION. IN NO CASE WILL OPEN HOLES BE ALLOWED TO REMAIN UNATTENDED WITHOUT ADEQUATE TRAFFIC CONTROL.

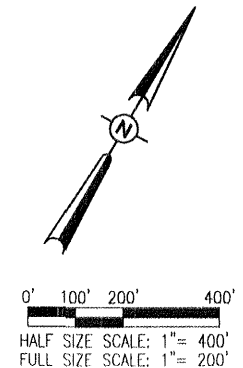

MAY 12, 2009 11:13 AM KINCA00394
 I:\AIRPORTS\SLA-CARBONDALE\08A0067\CADD\AIRPORT\SHEET\R-004STG.DWG - Layout1

| DATE | REVISION | BY |
|------|----------|----|
| | | |
| | | |
| | | |
| | | |
| | | |
| | | |
| | | |
| | | |
| | | |
| | | |

SOUTHERN ILLINOIS AIRPORT
 MURPHYSBORO / CARBONDALE, ILLINOIS

SIA
 SOUTHERN ILLINOIS AIRPORT

IL. PROJ.: MDH-3892 A.I.P. PROJ.: 3-17-0009-B29

| | | |
|----------------------------------|----------|----------|
| Hanson Project No. 08A0067D-0800 | DATE | 04/03/09 |
| Filename: R-004STG.DWG | DRAWN | BAK |
| Scale 1" = 200' | REVIEWED | CAH |
| Date 01/26/09 | | |

HANSON

Hanson Professional Services Inc.
 1525 South State Street
 Springfield, Illinois 62703-2886
 Offices Nationwide

REHABILITATE
 TAXIWAY "B"
 PROPOSED
 CONSTRUCTION
 SEQUENCING PLAN

SO078

RUNWAY 6-24

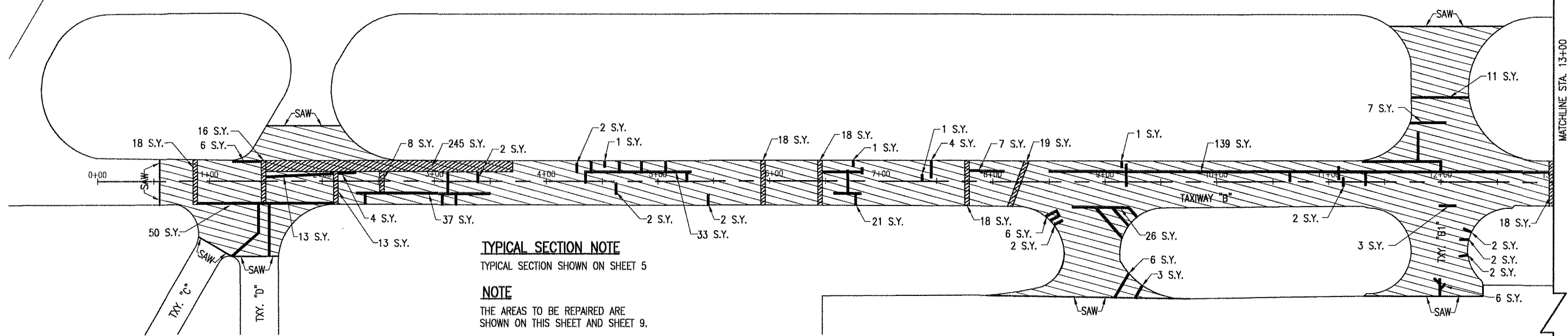

TYPICAL SECTION NOTE
TYPICAL SECTION SHOWN ON SHEET 5

NOTE
THE AREAS TO BE REPAIRED ARE SHOWN ON THIS SHEET AND SHEET 9.

RUNWAY 6-24

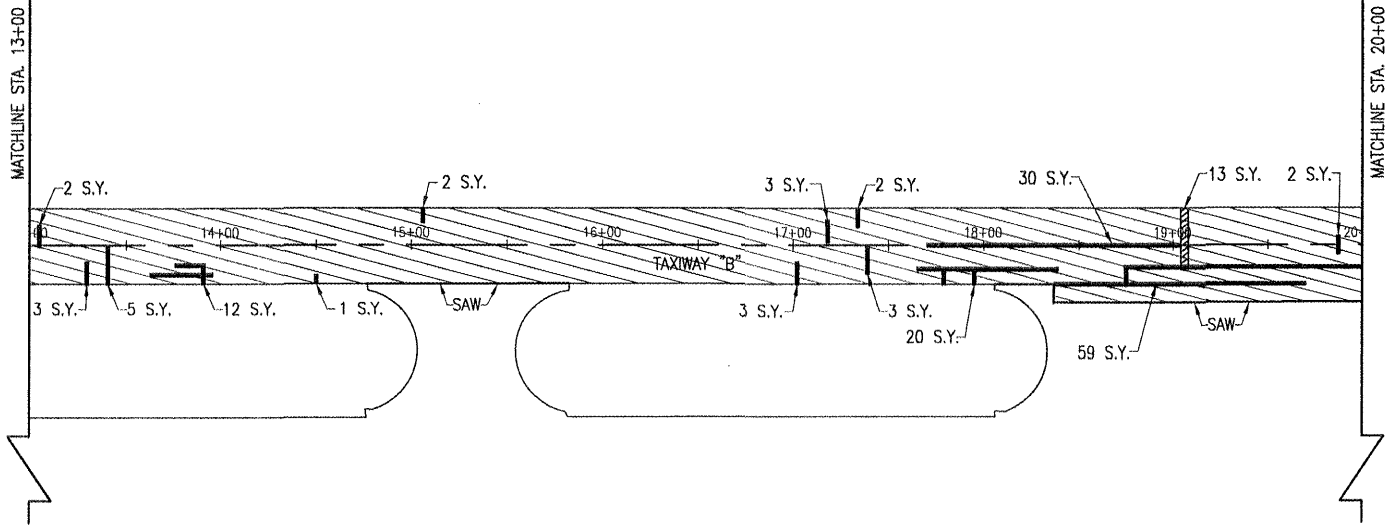

REM & REPL BIT PAVEMENT - TYPE A (AR401915)

A NOMINAL AMOUNT OF BITUMINOUS CRACK REPAIR HAS BEEN INCLUDED IN THE PLAN QUANTITIES BASED ON THE ANTICIPATION THAT SEVERAL, BUT NOT ALL, EXISTING CRACKS THAT ARE GREATER THAN 1 INCH IN WIDTH AT THE EXISTING SURFACE, BUT NOT EXHIBITING ROLLED EDGES, WILL NEED TO BE REPAIRED. THE QUANTITY INCLUDED IS BASED UPON A PAVEMENT CONDITION AND CRACK SURVEY WHICH WAS PERFORMED IN THE SPRING OF 2009. THE ACTUAL LENGTH AND NUMBER OF CRACKS TO BE REPAIRED AS PART OF THIS PROJECT WILL BE DESIGNATED BY THE RESIDENT ENGINEER AT THE TIME OF CONSTRUCTION, PRIOR TO THE MILLING OPERATIONS.

THE CRACKS SHALL BE CUT OPEN USING AN MILLING MACHINE AT A WIDTH OF 24", AND A DEPTH OF 3", FOLLOWING THE CRACK CENTERLINE AS CLOSELY AS OBTAINABLE WITH THE SUGGESTED EQUIPMENT. SEE SHEET 5 FOR THE TYPICAL SECTION OF THE EXISTING PAVEMENT (BASED ON RECORD AS-BUILT CONSTRUCTION PLANS).

THE EXCAVATED MATERIAL WILL BE DISPOSED OF OFF THE AIRPORT SITE BY THE CONTRACTOR.

AN APPLICATION OF BITUMINOUS TACK MATERIAL WILL BE APPLIED TO THE VERTICAL BITUMINOUS FACE. NO AGGREGATE BASE IS ANTICIPATED BASED ON RECORD AS-BUILT CONSTRUCTION PLANS. THE REPAIR TRENCH WILL BE BACKFILLED WITH BITUMINOUS SURFACE COURSE MATERIAL (401), IN ONE 3 INCH LIFT. THE REPAIRED AREA SHALL BE FLUSH WITH THE SURFACE OF THE EXISTING PAVEMENT. THE PATCH SHALL BE COMPACTED TO THE SATISFACTION OF THE RESIDENT ENGINEER AND ACCEPTED. NO NUCLEAR DENSITY TESTING SHALL BE REQUIRED FOR THIS TASK.

ANY DAMAGE TO THE EXISTING ADJACENT PAVEMENT WILL BE REPAIRED BY THE CONTRACTOR AT HIS EXPENSE. THE QUANTITY OF PAVEMENT REMOVAL, MILLING AND/OR SAWCUTS, IF UTILIZED, TACK MATERIAL, AND BITUMINOUS SURFACE COURSE MATERIAL (401) NECESSARY TO COMPLETE THIS TASK WILL BE CONSIDERED INCIDENTAL TO THE TASK, AND NO ADDITIONAL COMPENSATION WILL BE ALLOWED.

THE BITUMINOUS CRACK REPAIR WILL BE PAID FOR UNDER ITEM:
AR401915 REM & REPL BIT PAVEMENT - TYPE A - PER S.Y.

CLEAN & SEAL BITUMINOUS CRACKS (AR201661)

A PAVEMENT CONDITION AND CRACK SURVEY OF THE EXISTING TAXIWAY PAVEMENT WAS PERFORMED IN THE SPRING OF 2009, AND THE PLAN QUANTITY IS BASED UPON THE CONDITIONS PRESENT AT THE TIME OF THE SURVEY, AND THE ANTICIPATED CONDITIONS FOLLOWING THE MILLING OPERATIONS. THE EXACT AMOUNT OF CRACKS TO BE CLEANED AND SEALED WILL BE THE NUMBER OF LINEAR FEET OF CRACKS MARKED BY THE RESIDENT ENGINEER AT THE TIME OF CONSTRUCTION, AND FOLLOWING THE MILLING OPERATIONS.

ALL CRACKS DESIGNATED BY THE RESIDENT ENGINEER FOR CLEANING AND SEALING WILL BE DONE SO AS STATED IN THE SPECIAL PROVISIONS.

THIS ITEM OF WORK SHALL BE PAID FOR UNDER ITEM:
AR201661 CLEAN & SEAL BITUMINOUS CRACKS - PER L.F.

LEGEND

- EXISTING IMPROVEMENTS
- PROPOSED MILLING
- PROPOSED 2' WIDE, 3 INCH DEPTH PATCHES
- PROPOSED FULL DEPTH PATCHES

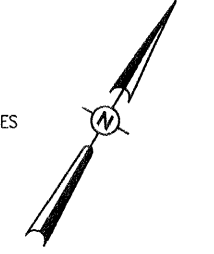

0' 25' 50' 100'
HALF SIZE SCALE: 1" = 100'
FULL SIZE SCALE: 1" = 50'

| REVISION | DATE | BY |
|----------|------|----|
| | | |
| | | |
| | | |
| | | |
| | | |
| | | |
| | | |
| | | |
| | | |
| | | |

SOUTHERN ILLINOIS AIRPORT
MURPHYSBORO / CARBONDALE, ILLINOIS

IL PROJ.: MDH-3892 A.I.P. PROJ.: 3-17-0009-B29

| | | | |
|------------------------------------|------------------------|---------------|---------------------|
| Revision Project No. 08A0067D 0800 | FILENAME R-111.PRP.DWG | DATE 01/26/09 | LAYOUT JSL 04/03/09 |
| Scale 1" = 50' | DATE 01/26/09 | DATE 01/26/09 | DATE 04/10/09 |
| | | | |
| | | | |
| | | | |
| | | | |
| | | | |
| | | | |
| | | | |
| | | | |

Hanson Professional Services Inc.
1525 South Sixth Street
Springfield, Illinois 62703-2886
Offices Nationwide

REHABILITATE TAXIWAY "B"
PROPOSED PAVEMENT PREPARATION PLAN
STA. 0+00 TO STA. 20+00

MAY 12, 2009 9:36 AM KINCA00394
 U:\AIRPORTS\SA-CARBONDALE\CADD\AIRPORT\SHEET\R-111.PRP.DWG - Layout1

REMOVE & REPLACE BIT. PAVEMENT-TYPE B (AR401916)

ITEM AR401916 REM & REPL BIT PAVEMENT - TYPE B WILL BE UTILIZED TO PERFORM LARGE CRACK REPAIR AND PAVEMENT FAILURE AREAS AND SHALL BE COMPLETED BEFORE THE EXISTING SURFACE IS MILLED..

THE QUANTITY OF CRACKS TO BE REPAIRED WAS ESTABLISHED BY THE COMPLETION OF A PAVEMENT CONDITION AND CRACK SURVEY PERFORMED IN THE SPRING OF 2009, AND CONSISTS OF THOSE CRACKS FOUND TO BE GREATER THAN ONE INCH IN WIDTH AT THE TIME OF THE SURVEY, AND EXHIBITING ROLLED EDGES. ALL CRACKS TO RECEIVE REPAIR SHALL BE LOCATED AND MARKED BY THE RESIDENT ENGINEER.

THE EDGE OF THE TRENCH FORMED WILL HAVE A VERTICAL FACE PRIOR TO THE PLACEMENT OF THE BITUMINOUS MATERIAL. THE WIDTH OF REPAIR WILL MARKED BY THE RESIDENT ENGINEER, BUT IN NO CASE BE LESS THAN 4 FEET IN WIDTH. THE DEPTH OF REPAIR WILL BE THE FULL DEPTH OF THE EXISTING PAVEMENT. SEE THE TYPICAL SECTIONS, SHEET 4, FOR THE EXISTING PAVEMENT DEPTHS (BASED ON RECORD AS-BUILT CONSTRUCTION PLANS).

THE CONTRACTOR WILL DISPOSE OF THE EXCAVATED MATERIAL OFF THE AIRPORT SITE AT NO ADDITIONAL COST TO THE CONTRACT.

THE BOTTOM OF THE TRENCH WILL BE CLEANED AND COMPACTED TO PREVENT FUTURE SETTLEMENT, AND ACCEPTED BY THE RESIDENT ENGINEER. ONCE THE TRENCH IS CLEANED, THE BASE AGGREGATE COMPACTED, AND ACCEPTED, AN APPLICATION OF BITUMINOUS TACK MATERIAL WILL BE APPLIED TO THE VERTICAL BITUMINOUS FACE AND THE AGGREGATE BASE. THE REPAIR TRENCH WILL BE BACKFILLED WITH BITUMINOUS SURFACE COURSE MATERIAL (401), IN LIFTS NOT TO EXCEED 3 INCHES IN DEPTH. THE FINAL LIFT SHALL BE FLUSH WITH THE SURFACE OF THE EXISTING BITUMINOUS PAVEMENT. EACH LIFT SHALL BE COMPACTED AND ACCEPTED BY THE RESIDENT ENGINEER.

ANY DAMAGE TO THE EXISTING ADJACENT PAVEMENT WILL BE REPAIRED BY THE CONTRACTOR AT HIS EXPENSE. THE QUANTITY OF PAVEMENT REMOVAL, MILLING AND/OR SAWCUTS, IF UTILIZED, TACK MATERIAL, AND BITUMINOUS SURFACE COURSE MATERIAL (401) NECESSARY TO COMPLETE THIS TASK WILL BE CONSIDERED INCIDENTAL TO THE TASK, AND NO ADDITIONAL COMPENSATION WILL BE ALLOWED.

THE QUANTITY OF BITUMINOUS PAVEMENT REPAIR TO BE PAID FOR SHALL BE THE NUMBER OF SQUARE YARDS OF PAVEMENT REMOVED AND REPLACED, IN ACCORDANCE WITH THE SPECIAL PROVISIONS, CONSTRUCTION DRAWINGS, AND ACCEPTED BY THE ENGINEER.

THIS ITEM OF WORK SHALL BE PAID FOR UNDER ITEM:
AR401916 REM & REPL BIT PAVEMENT-TYPE B - PER S.Y.

BITUMINOUS PAVEMENT MILLING (AR401650)

THE AREAS DESIGNATED AS [Hatched Pattern] ON THIS SHEET SHALL BE REMOVED USING A ROTO-MILLING EQUIPMENT. THE TOLERANCE OF THE MILLING WILL BE AS STATED IN THE STANDARD SPECIFICATIONS.

THE PROPOSED MILLING DEPTH IS 1.5 INCHES. THE CONTRACTOR WILL MONITOR THE MILLING OPERATION FOR DELAMINATION OF THE EXISTING PAVEMENT.

ALL MILLED MATERIAL WILL BE DISPOSED OFF OF THE AIRPORT SITE, EXCEPT THAT THE AIRPORT WILL RECEIVE 5-10 TANDEM LOADS OF THE CUTTINGS SEE SHEET 3, PROPOSED SAFETY PLAN, FOR LOCATION OF WASTE AREA.

PRIOR TO APPLYING THE BITUMINOUS OVERLAY ALL MILLED MATERIAL WILL BE BROOMED AND BLOWN CLEAN AND A BITUMINOUS TACK COAT APPLIED. THE VERTICAL FACE OF ALL SAW CUTS WILL BE PAINTED WITH A LIQUID ASPHALT.

ANY ADJACENT PAVEMENT DAMAGED BY THE MILLING OPERATIONS WILL BE REPAIRED AT THE CONTRACTOR'S OWN EXPENSE.

ALL BITUMINOUS PAVEMENT MILLING AREAS WILL BE LOCATED AND MARKED BY THE RESIDENT ENGINEER.

ALL PAVEMENT REPAIR (AR401915 & AR401916) SHALL BE ACCOMPLISHED BEFORE ANY MILLING OPERATIONS ARE CONDUCTED.

THIS ITEM OF WORK SHALL BE PAID FOR UNDER ITEM:
AR401650 BITUMINOUS PAVEMENT MILLING - PER S.Y.

SO078

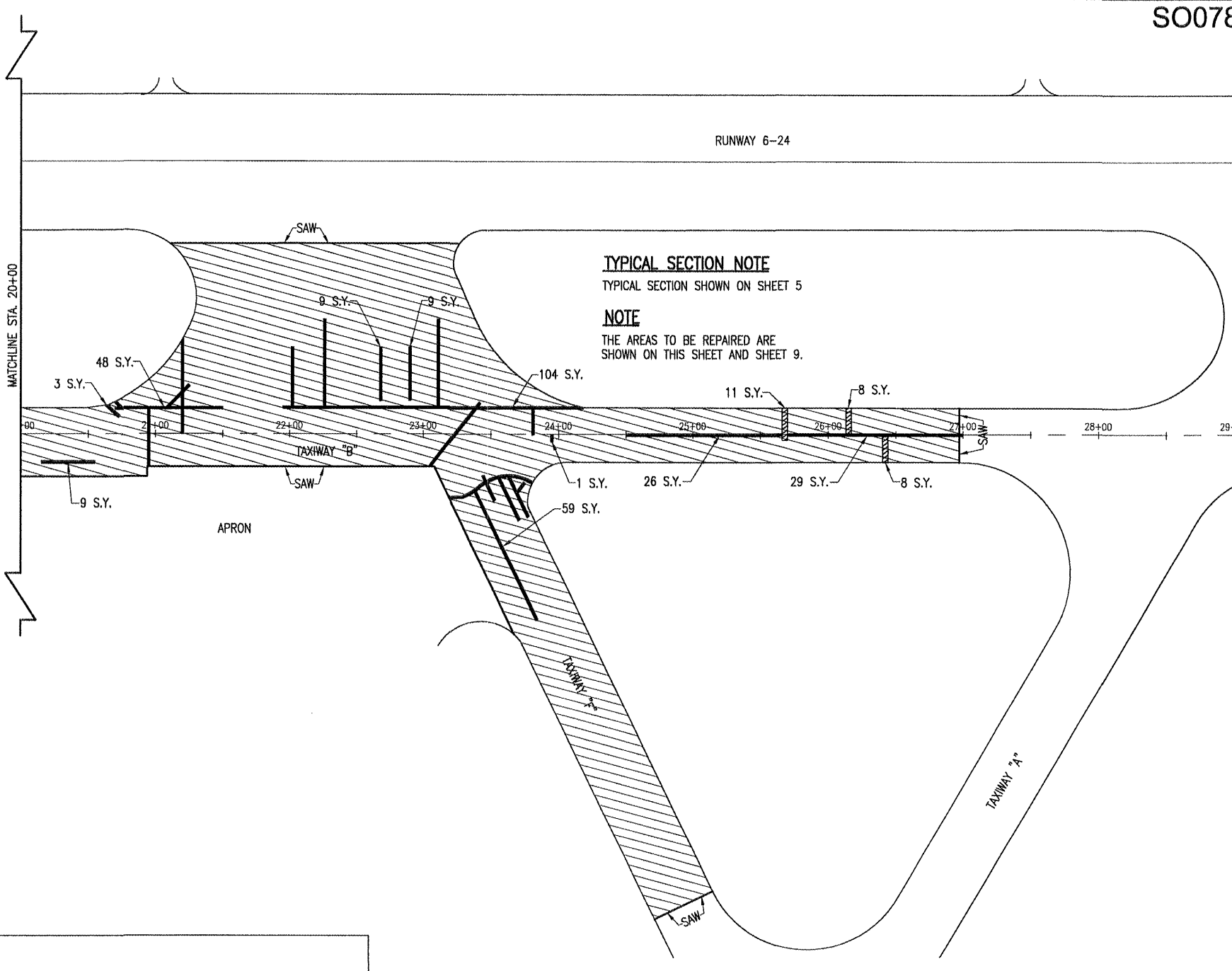

TYPICAL SECTION NOTE
TYPICAL SECTION SHOWN ON SHEET 5

NOTE
THE AREAS TO BE REPAIRED ARE SHOWN ON THIS SHEET AND SHEET 9.

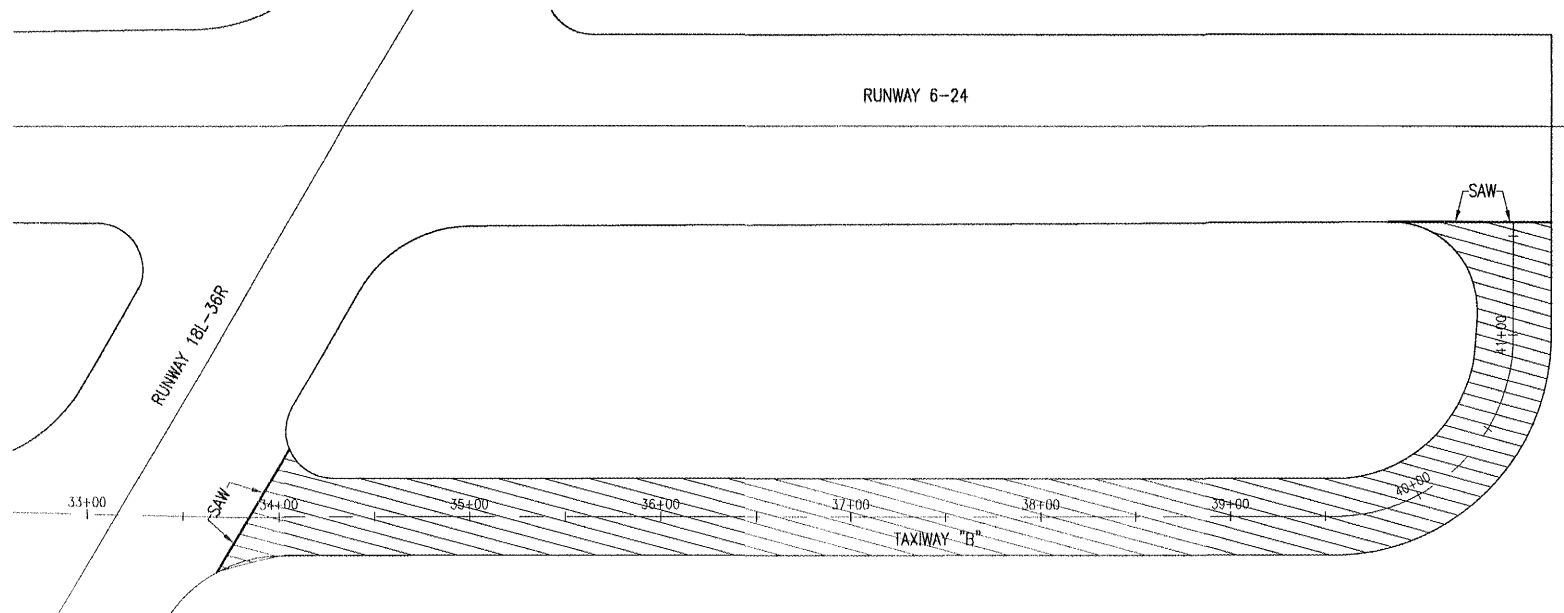

- LEGEND**
- [Solid Line] EXISTING IMPROVEMENTS
 - [Hatched Pattern] PROPOSED MILLING
 - [Dashed Line] PROPOSED 2' WIDE PARTIAL DEPTH PATCHES
 - [Diagonal Hatched Pattern] PROPOSED FULL DEPTH PATCHES

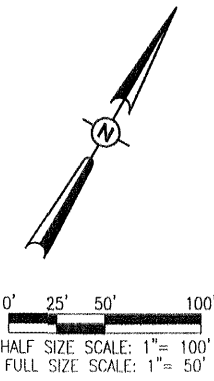

| DATE | REVISION | BY |
|------|----------|----|
| | | |
| | | |
| | | |

SOUTHERN ILLINOIS AIRPORT
MURPHYSBORO / CARBONDALE, ILLINOIS

IL PROJ.: MDH-3892 A.I.P. PROJ.: 3-17-0009-B29

| | | |
|----------------------------------|-------|----------|
| Hanson Project No. 08A0067D-0800 | DATE | 04/03/09 |
| Filename: R-111.PRP.DWG | SCALE | 1" = 50' |
| Scale | DATE | 01/26/09 |
| LAYOUT | DATE | 04/03/09 |
| DRAWN | DATE | 01/26/09 |
| REVIEWED | DATE | 04/10/09 |

Hanson Professional Services Inc.
1525 South State Street
Springfield, Illinois 62703-2886
Offices Nationwide

REHABILITATE TAXIWAY "B"
PROPOSED PAVEMENT PREPARATION PLAN
STA. 20+00 TO STA. 27+00

MAY 12, 2009 11:05 AM KINCA00394
I:\AIRPORTS\SIA-CARBONDALE\08A0067\CADD\AIRPORT\SHEET\R-111.PRP.DWG - Layout1 (2)

MAY 12, 2009 10:00 AM KINCA00394
 I:\AIRPORTS\SIA-CARBONDALE\08A0067\CADD\AIRPORT\SHEET\R-151MRK.DWG -- Layout1

SO078

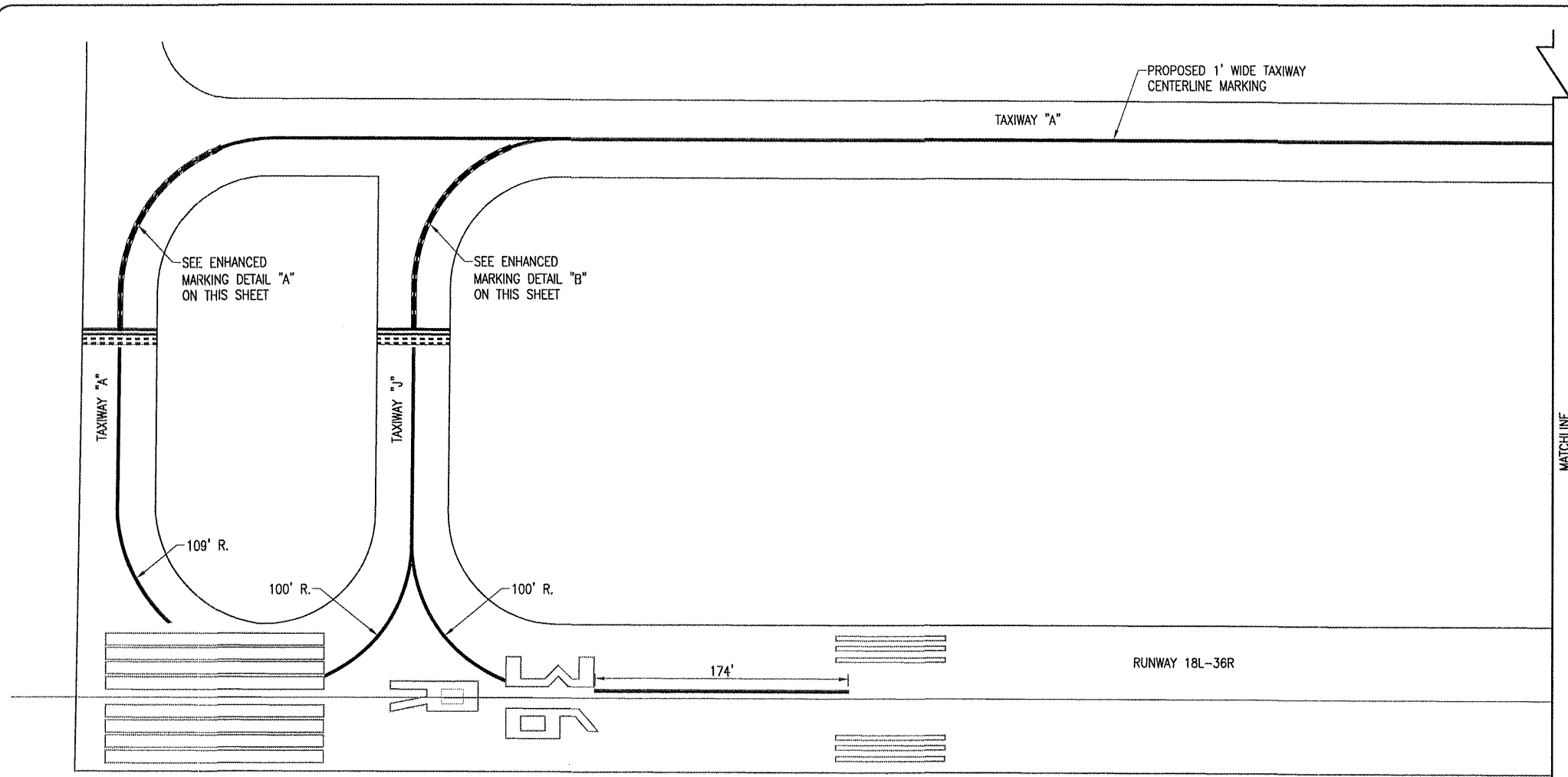

PAVEMENT MARKING-WATERBORNE (AR620520) AND PAVEMENT MARKING-BLACK BORDER (AR620525)

THE PAVEMENT MARKING-WATERBORNE (620) SHALL BE PLACED IN ACCORDANCE WITH ITEM 620 "PAVEMENT MARKING" AS STATED IN THE SUPPLEMENTAL SPECIFICATIONS AND RECURRING SPECIAL PROVISIONS, ADOPTED JULY 1, 2004.

ANY MATERIAL DELIVERED THAT FAILS TO MEET THE SPECIFICATIONS SHALL BE DISPOSED OF BY THE CONTRACTOR AND IMMEDIATELY REPLACED WITH ACCEPTABLE MATERIAL ENTIRELY AT THE CONTRACTOR'S EXPENSE, INCLUDING HANDLING AND TRANSPORTATION CHARGES.

TAXIWAY CENTERLINE MARKING SHALL BE SOLID AND YELLOW IN COLOR AND BE A WIDTH AS SHOWN ON THESE MARKING SHEETS. THE HOLDING POSITION MARKINGS WILL BE AS SPECIFIED IN THE DETAILS SHOWN ON SHEET 15.

ALL PROPOSED MARKING WILL BE COMPLETED IN ACCORDANCE WITH THE DETAILS SHOWN ON THE CONSTRUCTION PLANS.

THE PROPOSED PAVEMENT MARKING WILL BE APPLIED IN TWO APPLICATIONS. ALL PROPOSED YELLOW, RED & WHITE MARKING WILL HAVE A REFLECTIVE MEDIA APPLIED IN ACCORDANCE WITH THE SPECIFICATIONS. GLASS BEADS SHALL BE REQUIRED IN THE SECOND APPLICATION ONLY. BLACK BORDER WILL NOT REQUIRE REFLECTIVE MEDIA.

CUT-OFF SHEETS WILL BE REQUIRED TO INSURE STRAIGHT EDGES.

PROPOSED MARKING ITEMS WILL BE PAID FOR AS FOLLOWS:
 AR620520 PAVEMENT MARKING-WATERBORNE - PER S.F.
 AR620525 PAVEMENT MARKING-BLACK BORDER - PER S.F.

ENHANCED MARKING NOTE:

THE ENHANCED TAXIWAY MARKING WILL BE CONSTRUCTED TO THE DIMENSIONS AND COLORS AS SHOWN ON THE "ENHANCED TAXIWAY MARKING DETAIL" AS SHOWN ON SHEET NO. 15.

THE ENHANCED TAXIWAY MARKING WILL START AT THE EDGE OF THE ASSOCIATED HOLD LINE'S BLACK BORDER. THE ENHANCED MARKING WILL EXTEND FOR 150' FROM THIS POINT, UNLESS SHOWN OTHERWISE.

IN THE CASE WHERE THE TAXIWAY CENTERLINE FOLLOWS A RADIUS, THE ENHANCED MARKING WILL FOLLOW THE RADIUS AS SHOWN ON THE CORRESPONDING DETAILS. THE 150' WILL BE MEASURED ALONG THE CENTER OF THE TAXIWAY CENTERLINE AND WILL EXTEND FOR AN OVER ALL LENGTH OF 150', UNLESS SHOWN OTHERWISE.

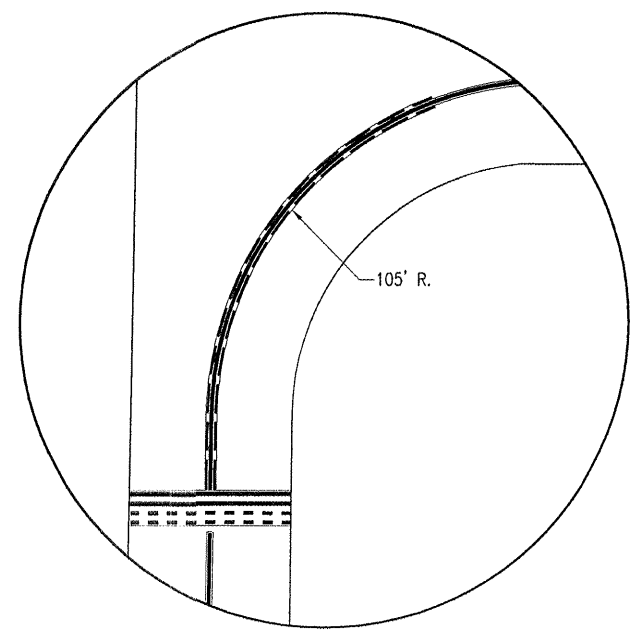

DETAIL "A"
 SCALE 1" = 30'

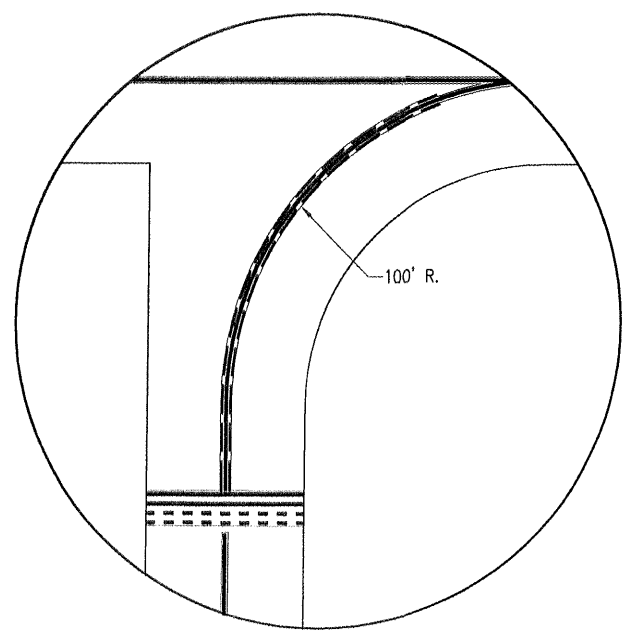

DETAIL "B"
 SCALE 1" = 30'

| MARKING QUANTITIES | | | | |
|--------------------|---------------------------------|------|----------|-------------------|
| ITEM NO. | DESCRIPTION | UNIT | QUANTITY | AS BUILT QUANTITY |
| AR620520 | PAVEMENT MARKING - WATERBORNE | S.F. | 37,766 | |
| AR620525 | PAVEMENT MARKING - BLACK BORDER | S.F. | 43,371 | |

- LEGEND**
- EXISTING PAVEMENT
 - EXISTING PAVEMENT MARKING
 - PROPOSED PAVEMENT MARKING

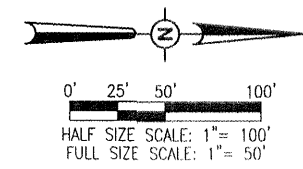

| DATE | REVISION | BY |
|------|----------|----|
| | | |
| | | |
| | | |
| | | |
| | | |
| | | |
| | | |
| | | |
| | | |
| | | |

SOUTHERN ILLINOIS AIRPORT
 MURPHYSBORO / CARBONDALE, ILLINOIS

IL PROJ.: MDH-3892 A.I.P. PROJ.: 3-17-0009-B29

| | | |
|----------------------------------|----------------|---------------|
| Hanson Project No. 08A0067D-0800 | Scale 1" = 50' | DATE 04/03/09 |
| Plan Name R-151MRK.DWG | DATE 01/26/09 | DATE 01/26/09 |
| DATE 01/26/09 | DATE 01/26/09 | DATE 04/10/09 |
| LAYOUT | ISL | CAH |
| DRAWN | BAK | CAH |
| REVIEWED | CAH | CAH |

Hanson Professional Services Inc.
 1525 South Sixth Street
 Springfield, Illinois 62703-2886
 Offices Nationwide

REHABILITATE TAXIWAY "B"
 PROPOSED MARKING PLAN

MAY 12, 2009 10:59 AM KINGA00394
 I:\AIRPORTS\SLA-CARBONDALE\08A0067\CADD\AIRPORT\ SHEET\ R-151MRK.DWG - Layout1 (3)

SO078

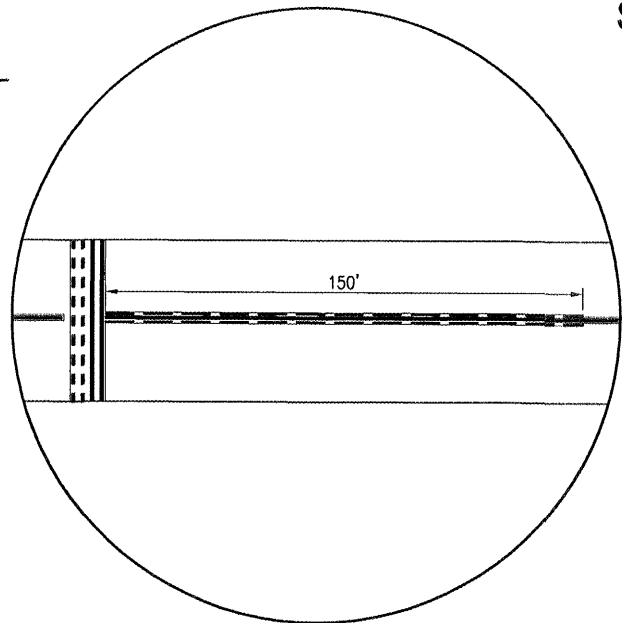
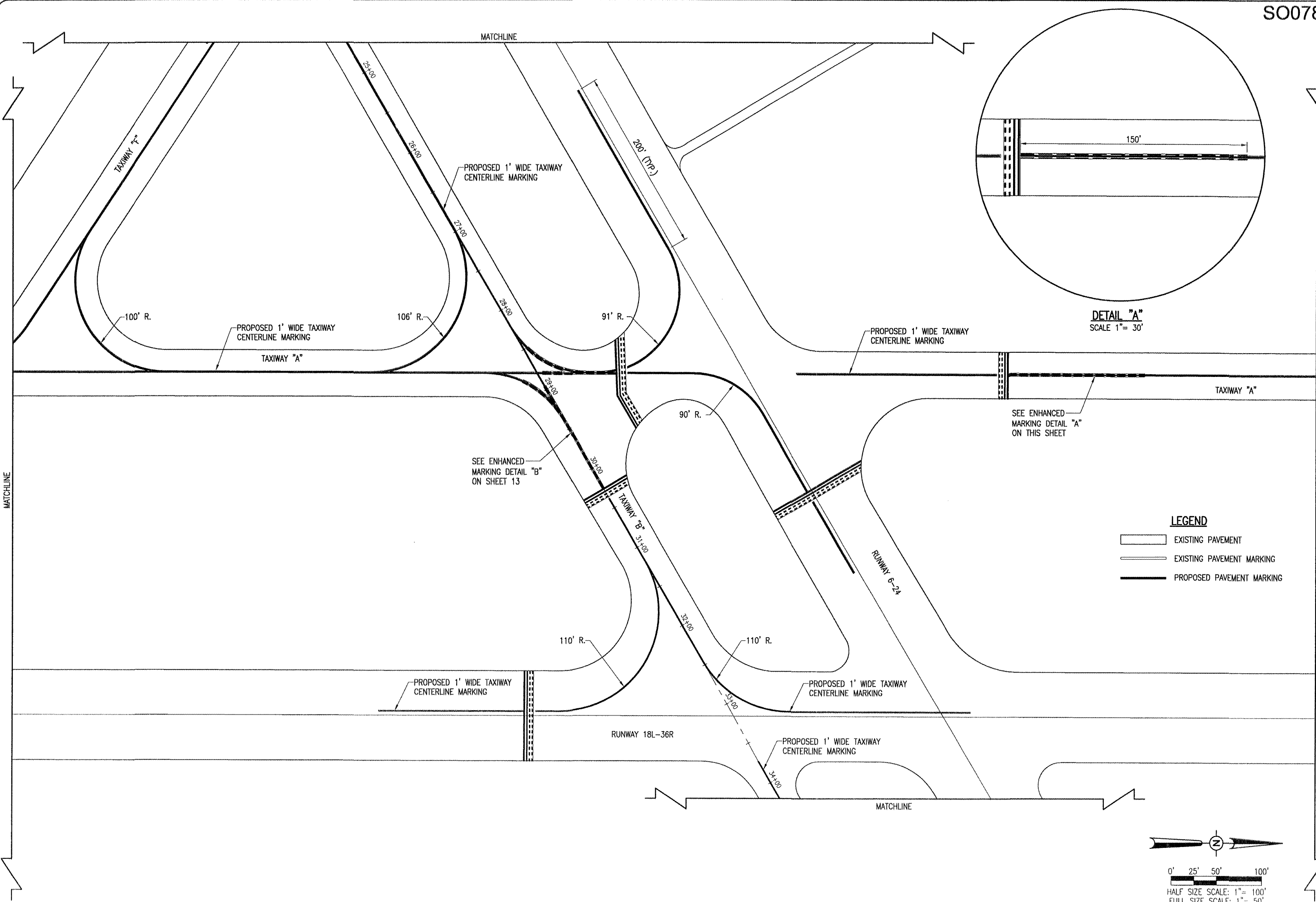

DETAIL "A"
 SCALE 1" = 30'

- LEGEND**
- EXISTING PAVEMENT
 - EXISTING PAVEMENT MARKING
 - PROPOSED PAVEMENT MARKING

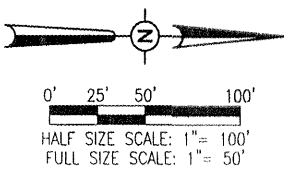

| DATE | REVISION | BY |
|------|----------|----|
| | | |
| | | |
| | | |
| | | |

SOUTHERN ILLINOIS AIRPORT
 MURPHYSBORO / CARBONDALE, ILLINOIS

SIA
 SOUTHERN ILLINOIS AIRPORT

IL. PROJ. MDH-3892 A.I.P. PROJ. 3-17-0009-B29

| | |
|----------------------------------|--|
| Hanson Project No. 08A0067D_0800 | |
| Drawings R-151MRK.DWG | |
| Scale 1" = 50' | |
| Date 01/26/09 | |
| LAYOUT JSL 04/03/09 | |
| DRAWN BAK 01/26/09 | |
| REVIEWED CAH 04/10/09 | |

HANSON

Hanson Professional Services Inc.
 1001 South Main Street
 Springfield, Illinois 62763-2886
 Offices Nationwide

REHABILITATE TAXIWAY "B"
 PROPOSED MARKING PLAN

MAY 12, 2009 11:29 AM KINCA00394
 I:\AIRPORTS\SA-CARBONDALE\08A0067\CADD\AIRPORT\Sheet\R-151MRK.DWG - Layout1 (4)

SO078

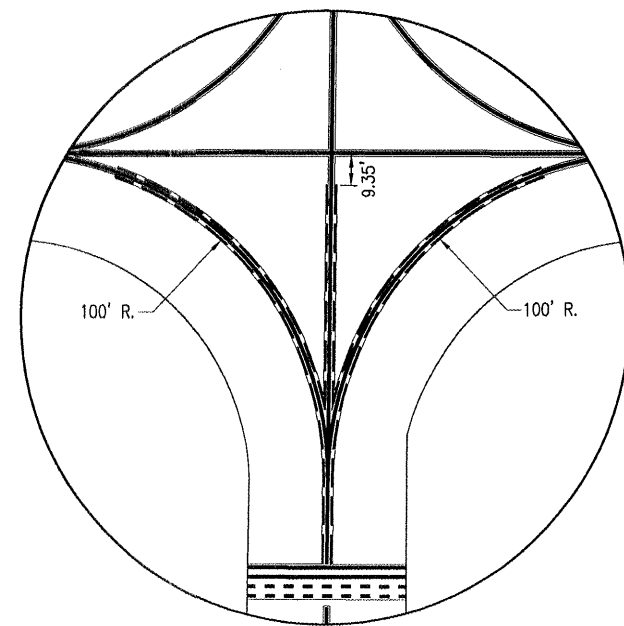
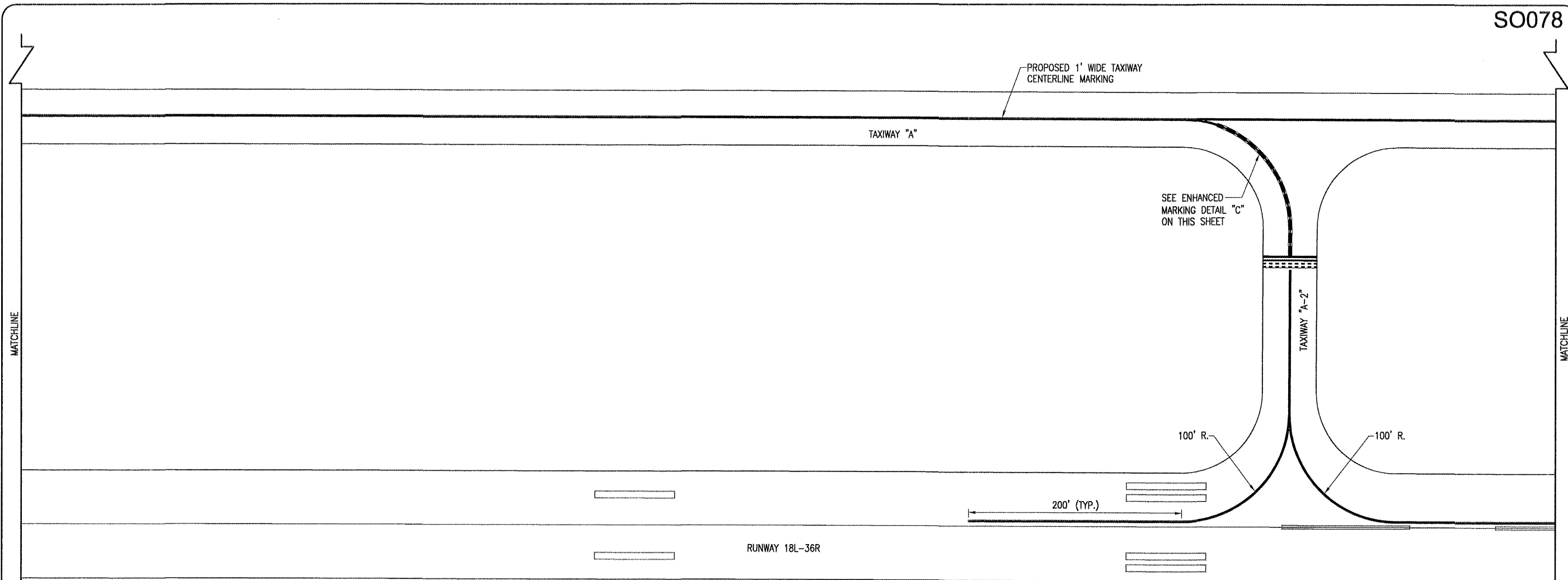

DETAIL "A"
 SCALE 1" = 30'

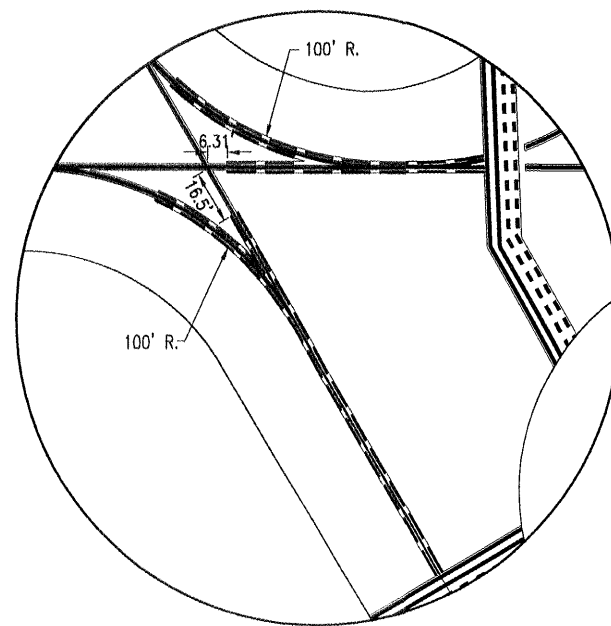

DETAIL "B"
 SCALE 1" = 30'

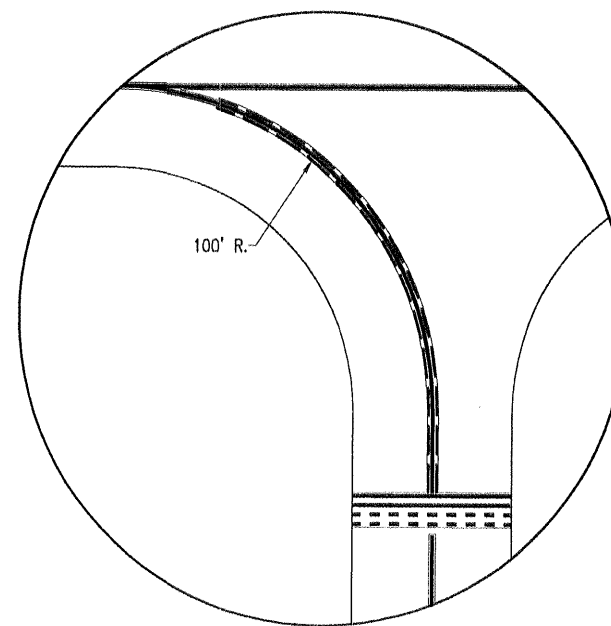

DETAIL "C"
 SCALE 1" = 30'

- LEGEND**
- EXISTING PAVEMENT
 - EXISTING PAVEMENT MARKING
 - PROPOSED PAVEMENT MARKING

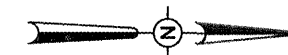

0' 25' 50' 100'
 HALF SIZE SCALE: 1" = 100'
 FULL SIZE SCALE: 1" = 50'

| REVISION | DATE | BY |
|----------|------|----|
| | | |
| | | |
| | | |

SOUTHERN ILLINOIS AIRPORT
 MURPHYSBORO / CARBONDALE, ILLINOIS

SIA
 SOUTHERN ILLINOIS AIRPORT

IL PROJ.: MDH-3892 A.I.P. PROJ.: 3-17-0009-B29

| | |
|----------------------------------|-----------------------|
| Hanson Project No. 08A0067D_0800 | FILENAME R-151MRK.DWG |
| Scale 1" = 50' | Date 01/26/09 |
| LAYOUT JSL 04/03/09 | DRAWN BAK 01/26/09 |
| REVIEWED CAH 04/10/09 | |

HANSON

Hanson Professional Services, Inc.
 1525 South Sixth Street
 Springfield, Illinois 62703-2856
 Offices Nationwide

REHABILITATE
 TAXIWAY "B"
 PROPOSED
 MARKING
 PLAN

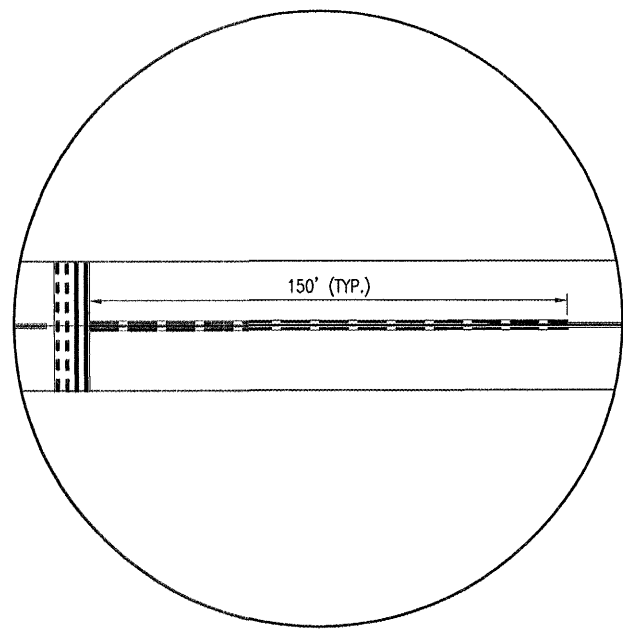

DETAIL "A"
SCALE 1" = 30'

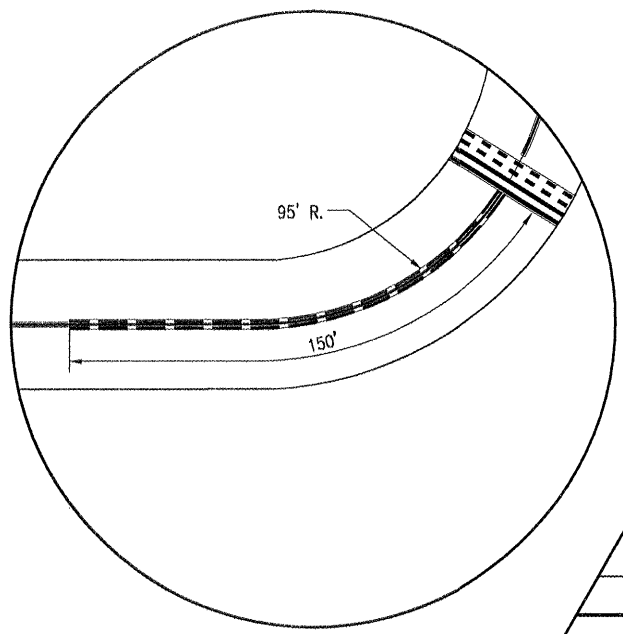

DETAIL "B"
SCALE 1" = 30'

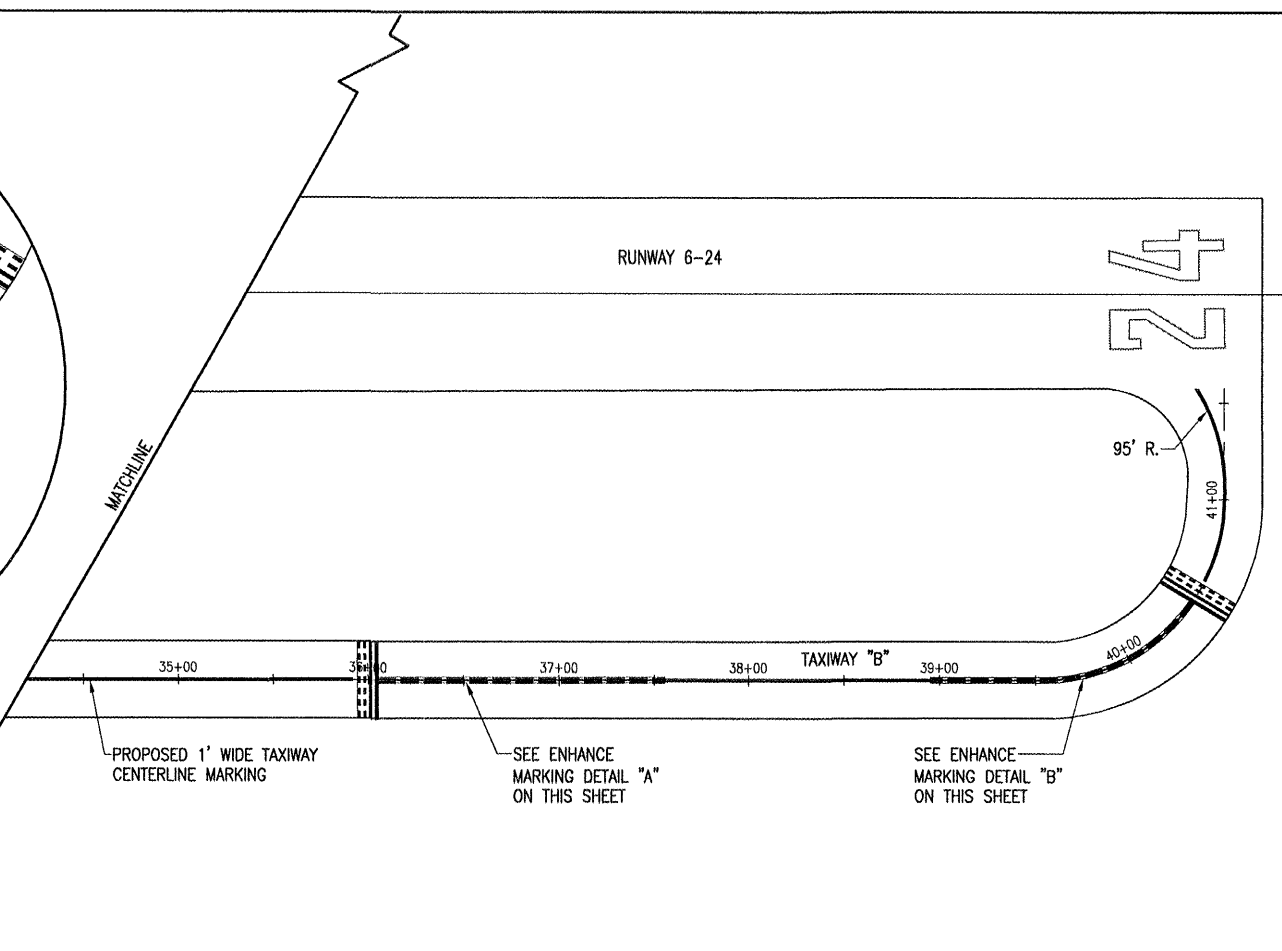

PROPOSED 1' WIDE TAXIWAY CENTERLINE MARKING

SEE ENHANCE MARKING DETAIL "A" ON THIS SHEET

SEE ENHANCE MARKING DETAIL "B" ON THIS SHEET

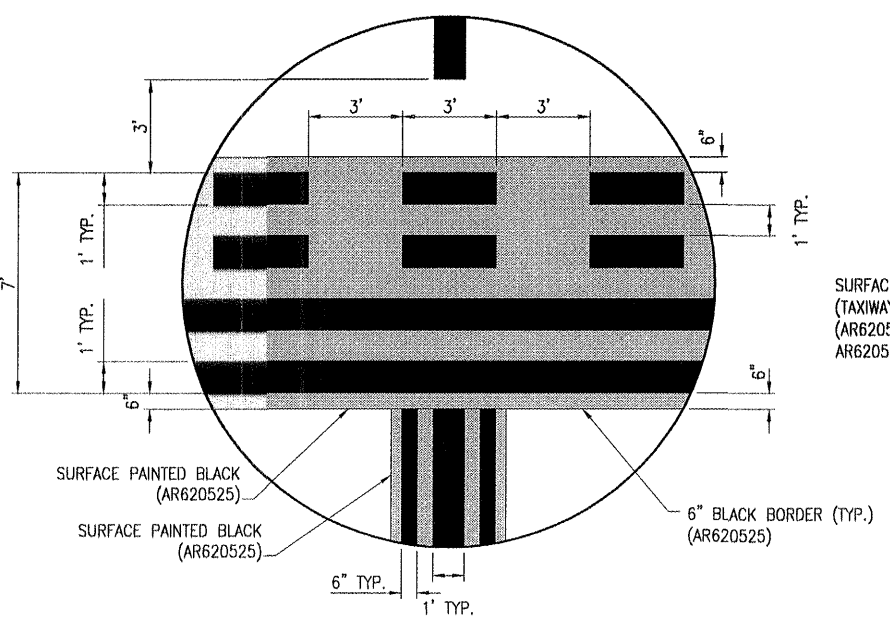

HOLDING POSITION DETAIL
"NOT TO SCALE"

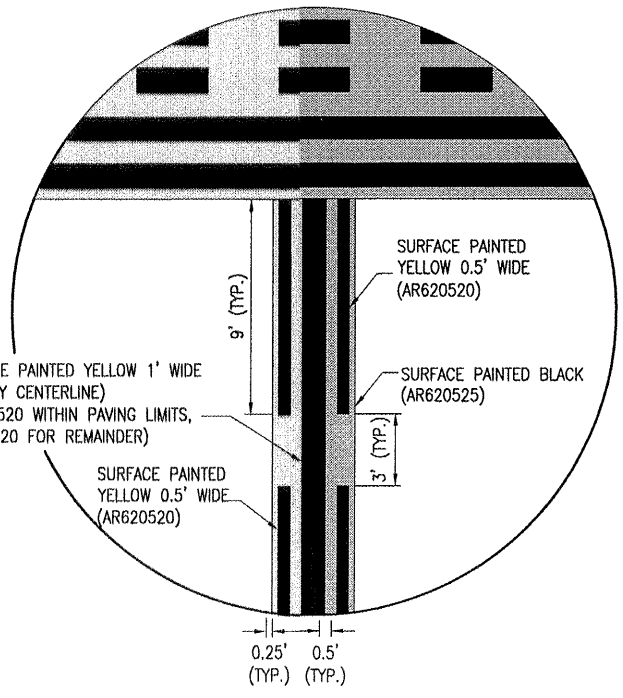

ENHANCED TAXIWAY MARKING DETAIL (BEGIN)
"NOT TO SCALE"

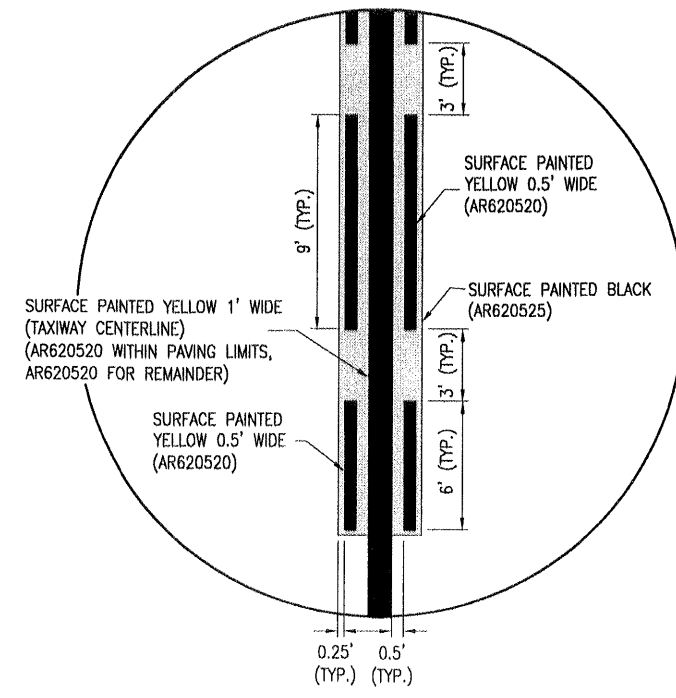

ENHANCED TAXIWAY MARKING DETAIL (END)
"NOT TO SCALE"

- LEGEND**
- EXISTING PAVEMENT
 - EXISTING PAVEMENT MARKING
 - PROPOSED PAVEMENT MARKING

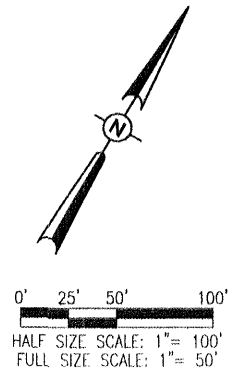

| DATE | REVISION | BY |
|------|----------|----|
| | | |
| | | |
| | | |

SOUTHERN ILLINOIS AIRPORT
MURPHYSBORO / CARBONDALE, ILLINOIS

SIA
SOUTHERN ILLINOIS AIRPORT

IL PROJ.: MDH-3892 A.I.P. PROJ.: 3-17-0009-B29

| | | | |
|----------------------------------|----------|-----|----------|
| Hanson Project No. 08A0057D_0800 | LAYOUT | JSL | 04/03/09 |
| Filename: R-151MRK.DWG | DRAWN | BAK | 01/26/09 |
| Scale: 1" = 50' | REVIEWED | CAH | 04/10/09 |
| Date: 01/26/09 | | | |

HANSON

Hanson Professional Services Inc.
1525 South Sixth Street
Springfield, Illinois 62703-2886
Offices Nationwide

REHABILITATE TAXIWAY "B"

PROPOSED MARKING PLAN

MAY 12, 2009 11:30 AM KINCA00394
I:\AIRPORTS\51A-CARBONDALE\08A0057\CADD\AIRPORT\SHEET\R-151MRK.DWG - Layout1 (6)

MAY 12, 2009 11:33 AM KINCAID0394
 I:\AIRPORTS\SIA-CARBONDALE\08A0067\CADD\AIRPORT\SHEET\R-151MRK.DWG - Layout1 (7)

SO078

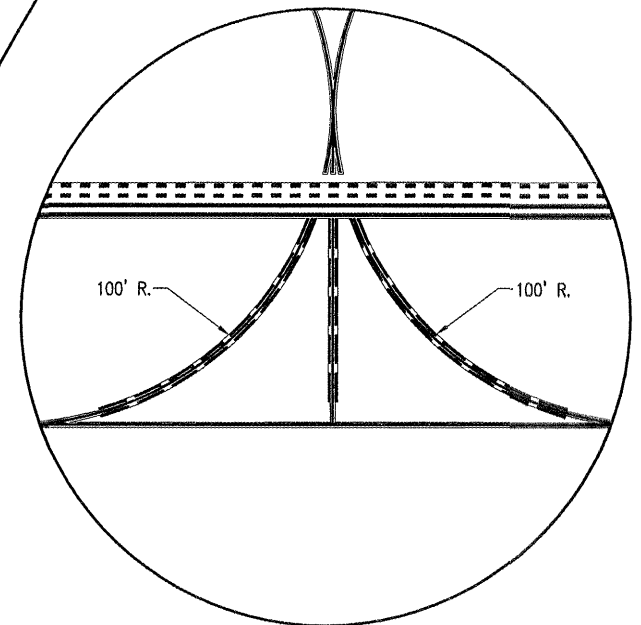
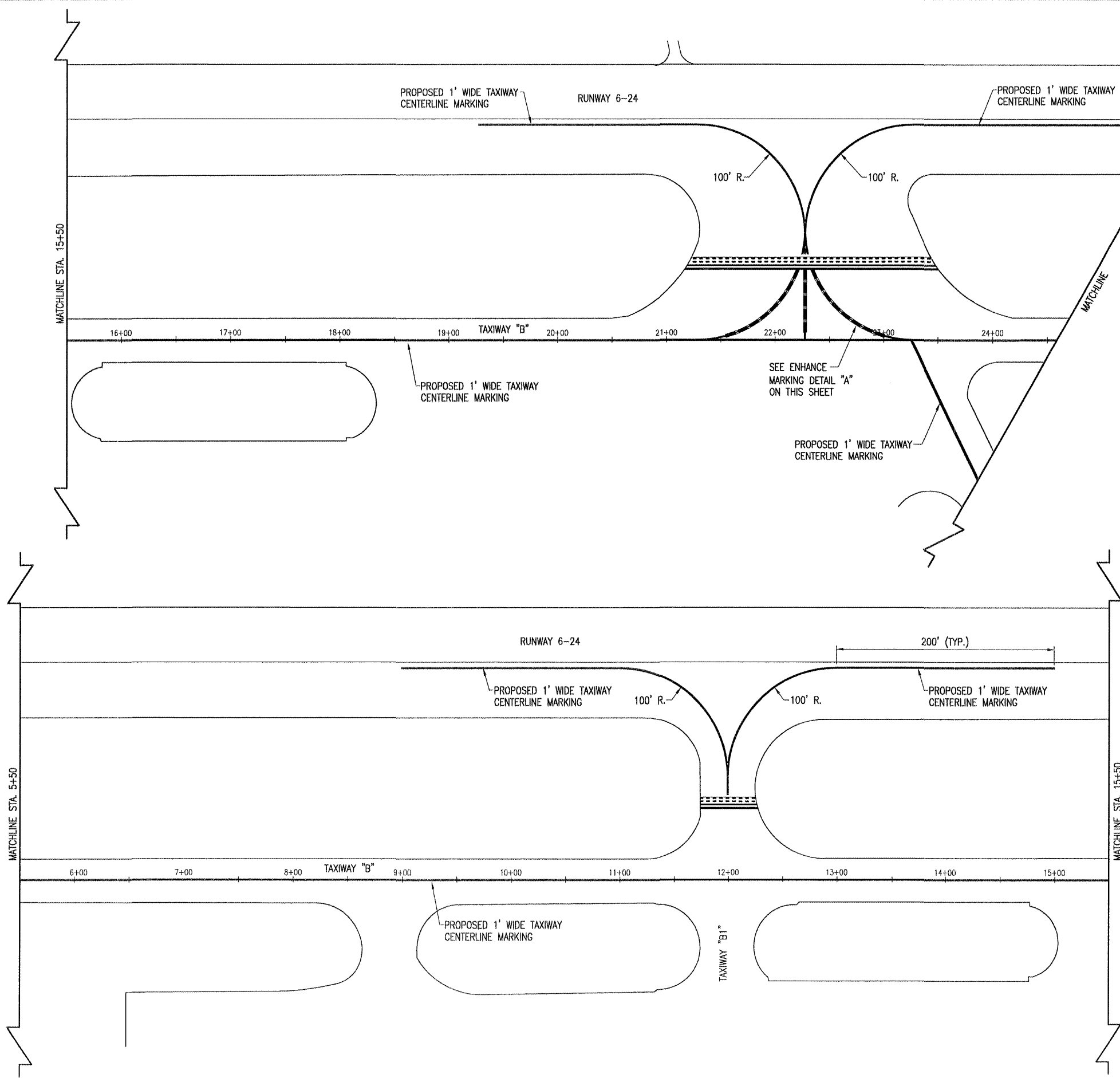

DETAIL "A"
 SCALE 1" = 30'

- LEGEND**
- EXISTING PAVEMENT
 - EXISTING PAVEMENT MARKING
 - PROPOSED PAVEMENT MARKING

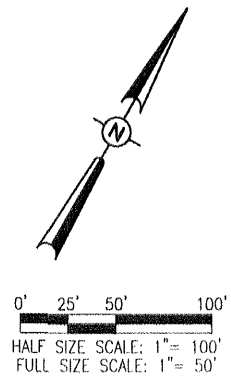

| DATE | REVISION | BY |
|------|----------|----|
| | | |
| | | |
| | | |
| | | |
| | | |
| | | |
| | | |
| | | |
| | | |

SOUTHERN ILLINOIS AIRPORT
 MURPHYSBORO / CARBONDALE, ILLINOIS

SIA
 SOUTHERN ILLINOIS AIRPORT

IL PROJ.: MDH-3892 A.I.P. PROJ.: 3-17-0009-B29

| | | | |
|----------------------------------|----------|-----|----------|
| Hanson Project No. 08A0067D-0800 | LAYOUT | JSL | 04/03/09 |
| Filename: R-151MRK.DWG | DRAWN | BAK | 01/26/09 |
| Scale: 1" = 50' | REVIEWED | CAH | 04/10/09 |
| Date: 01/26/09 | | | |

HANSON

Hanson Professional Services Inc.
 1525 South Sixth Street
 Springfield, Illinois 62703-2886
 Offices Nationwide

REHABILITATE TAXIWAY "B"

PROPOSED MARKING PLAN

MAY 12, 2009 11:36 AM KINCAID0394
 I:\AIRPORTS\SIA-CARBONDALE\08A0067\CADD\AIRPORT\SHEET\151MRK.DWG - Layout1 (10)

SO078

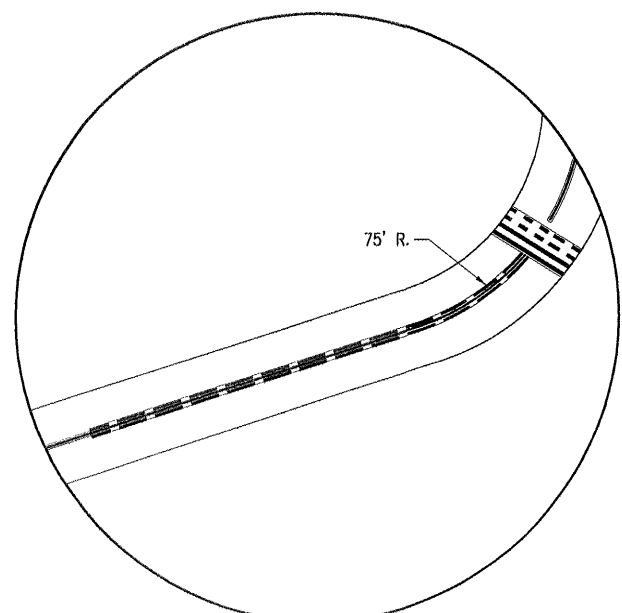
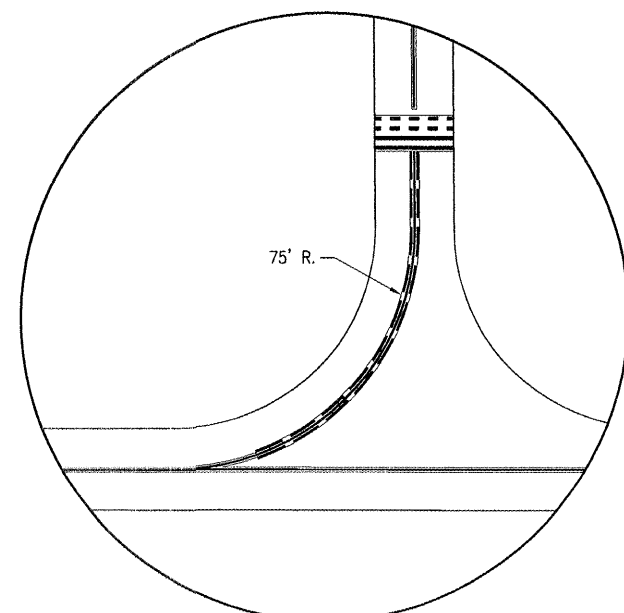
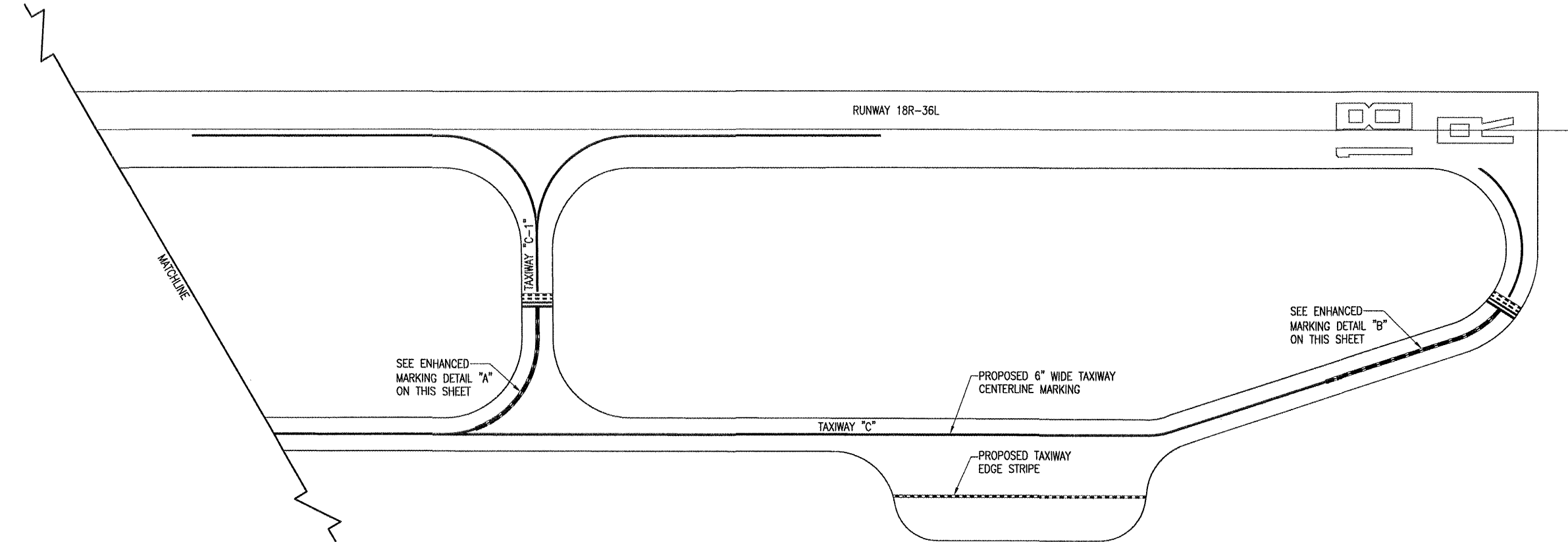

- LEGEND**
- EXISTING PAVEMENT
 - EXISTING PAVEMENT MARKING
 - PROPOSED PAVEMENT MARKING

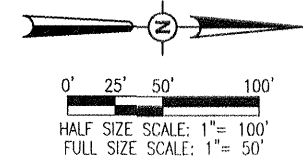

| DATE | REVISION | BY |
|------|----------|----|
| | | |
| | | |
| | | |
| | | |
| | | |
| | | |
| | | |
| | | |
| | | |
| | | |

SOUTHERN ILLINOIS AIRPORT
 MURPHYSBORO / CARBONDALE, ILLINOIS

IL PROJ.: MDH-3892 A.I.P. PROJ.: 3-17-0009-B29

| | |
|----------------------------------|----------|
| Hanson Project No. 08A0067D_0800 | 04/03/09 |
| Drawn By R-151MRK.DWG | 01/26/09 |
| Scale 1" = 50' | 01/26/09 |
| Date 01/26/09 | 04/10/09 |
| LAYOUT JSL | 04/03/09 |
| DRAWN BAK | 01/26/09 |
| REVIEWED CAH | 04/10/09 |

HANSON
 Hanson Professional Services Inc.
 1525 South Sixth Street
 Springfield, Illinois 62709-2886
 Offices Nationwide

REHABILITATE
 TAXIWAY "B"
 PROPOSED
 MARKING
 PLAN

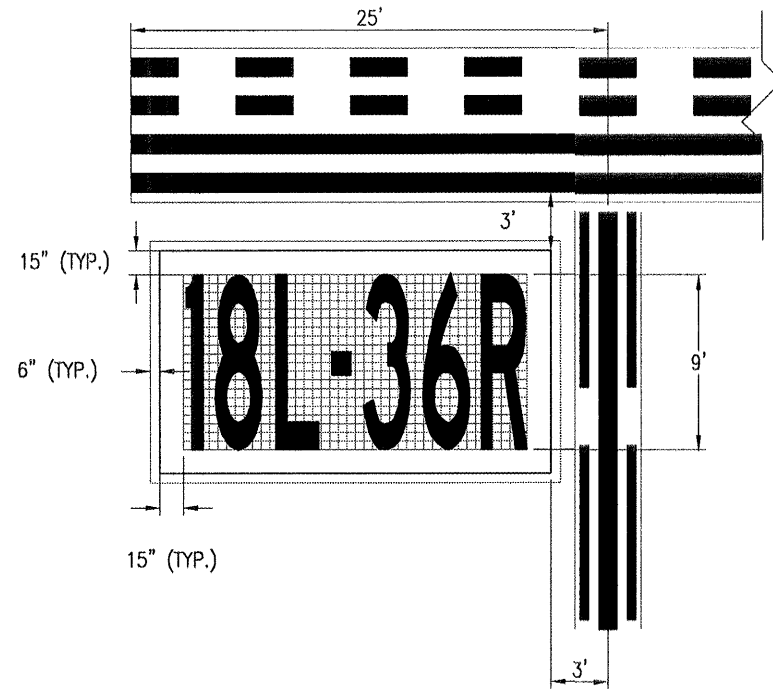

SURFACE PAINTED HOLDING POSITION SIGN DETAIL
 TAXIWAY A, A-1, A-2, B, G, H, J SHORT OF RUNWAY 18L-36R
 NOT TO SCALE

NOTE: GRID SHOWN FOR PROPER SIZING OF INSCRIPTIONS
 - NOT TO BE PAINTED. GRID SPACING IS 0.45 FEET.

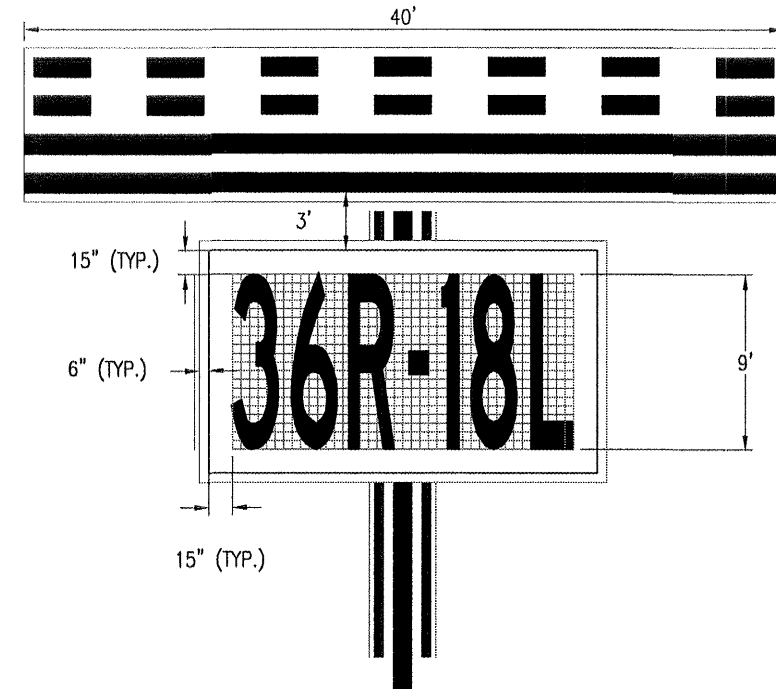

SURFACE PAINTED HOLDING POSITION SIGN DETAIL
 TAXIWAY B SHORT OF RUNWAY 36R-18L
 NOT TO SCALE

NOTE: GRID SHOWN FOR PROPER SIZING OF INSCRIPTIONS
 - NOT TO BE PAINTED. GRID SPACING IS 0.45 FEET.

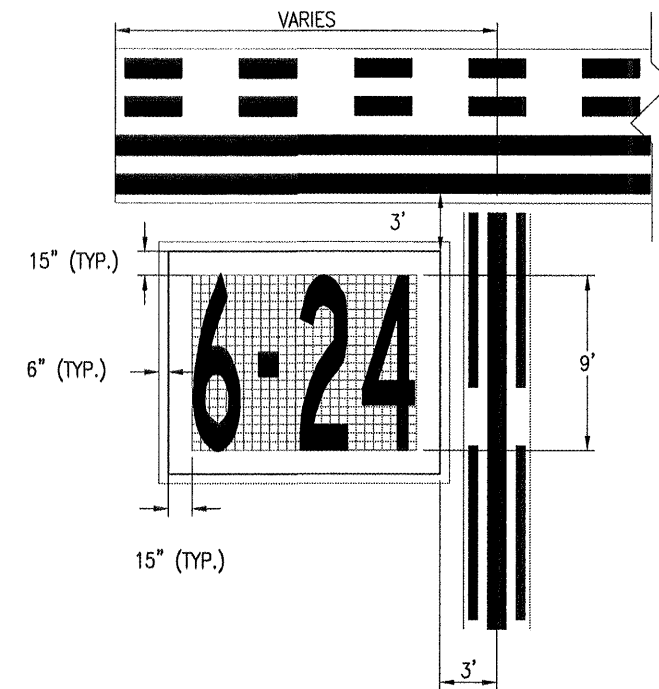

SURFACE PAINTED HOLDING POSITION SIGN DETAIL
 TAXIWAY B-1, B SHORT OF RUNWAY 6-24
 NOT TO SCALE

NOTE: GRID SHOWN FOR PROPER SIZING OF INSCRIPTIONS
 - NOT TO BE PAINTED. GRID SPACING IS 0.45 FEET.

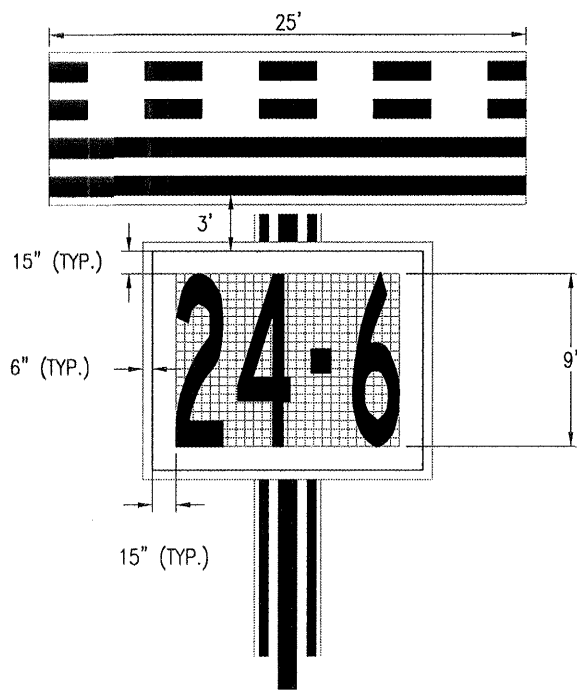

SURFACE PAINTED HOLDING POSITION SIGN DETAIL
 TAXIWAY C SHORT OF RUNWAY 24-6
 NOT TO SCALE

NOTE: GRID SHOWN FOR PROPER SIZING OF INSCRIPTIONS
 - NOT TO BE PAINTED. GRID SPACING IS 0.45 FEET.

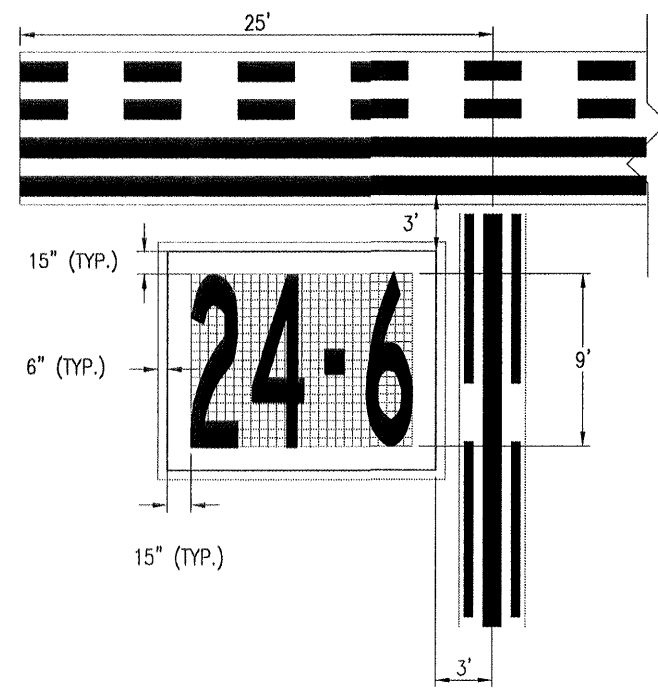

SURFACE PAINTED HOLDING POSITION SIGN DETAIL
 TAXIWAY A SHORT OF RUNWAY 24-6
 NOT TO SCALE

NOTE: GRID SHOWN FOR PROPER SIZING OF INSCRIPTIONS
 - NOT TO BE PAINTED. GRID SPACING IS 0.45 FEET.

SURFACE PAINTED HOLDING POSITION SIGN NOTES:

1. SURFACE PAINTED HOLDING POSITION SIGNS SHALL BE PAINTED FOLLOWING PAVING OPERATIONS AT THE LOCATIONS SHOWN ON THE PAVEMENT MARKING PLAN SHEETS. IT IS INTENDED THAT THE MARKINGS WILL ALSO BE PAINTED AT LOCATIONS OUTSIDE OF THE RESURFACED AREAS. THE CONTRACTOR SHALL FIELD VERIFY THAT THE SURFACE PAINTED HOLDING POSITION SIGNS MEET THE STANDARD DIMENSIONS SHOWN. THE CONTRACTOR SHALL NOTIFY THE RESIDENT ENGINEER OF ANY VARIATION FROM THE DIMENSIONS AND LOCATIONS SHOWN.
2. THE STENCILS FOR THE SURFACE PAINTED HOLDING POSITION SIGNS SHALL BE THE RESPONSIBILITY OF THE CONTRACTOR. AT THE CONCLUSION OF THE PROJECT, THE CONTRACTOR SHALL BE RESPONSIBLE FOR PROVIDING A SET OF STENCILS TO THE AIRPORT THAT MATCH THE SIGN DIMENSIONS PAINTED AT THIS AIRPORT.
3. THE SURFACE PAINTED HOLDING POSITION SIGNS SHALL BE ORIENTED PARALLEL TO THE RUNWAY HOLDING POSITION MARKING.
4. SURFACE PAINTED HOLDING POSITIONS SIGNS SHALL BE LOCATED BASED ON DIMENSIONS FROM THE TAXIWAY CENTERLINE AND RUNWAY HOLDING POSITION MARKING. IF THE TAXIWAY CENTERLINE AND THE RUNWAY HOLDING POSITION MARKING ARE NOT PERPENDICULAR TO TO EACH OTHER, THE DIMENSION FROM THE CENTERLINE SHALL BE MEASURED TO THE NEAREST POINT ON THE SURFACE PAINTED SIGN.

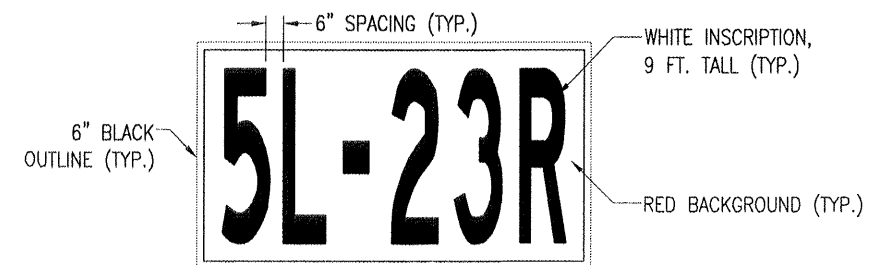

SURFACE PAINTED HOLDING POSITION SIGN DETAIL
 TYPICAL COLOR SCHEME
 NOT TO SCALE

| | |
|--|---------------|
| BY | |
| REVISION | |
| DATE | |
| | |
| SOUTHERN ILLINOIS AIRPORT MURPHYSBORO / CARBONDALE, ILLINOIS | |
| A.I.P. PROJ.: 3-17-0009-B29 IL PROJ.: MDH-3892 | |
| Hanson Project No. | 08A0067D-0800 |
| Filename | R-551MRK.DWG |
| Scale | NOT TO SCALE |
| Date | 01/26/09 |
| LAYOUT | JSL 04/03/09 |
| DRAWN | JSL 01/26/09 |
| REVIEWED | CAH 04/10/09 |
| | |
| Hanson Professional Services Inc. 1825 South State Street Springfield, Illinois 62703-2886 Offices Nationwide | |
| REHABILITATE TAXIWAY "B" PROPOSED SURFACE PAINTED HOLDING POSITION MARKING SIGN DETAILS | |
| 20 20 of 27 sheets | |

MAY 12, 2009 11:37 AM KINCAD0394
 C:\AIRPORTS\SH-CARBONDALE\08A0067\CADD\AIRPORT\SHEET\B-551MRK.DWG - Layout1

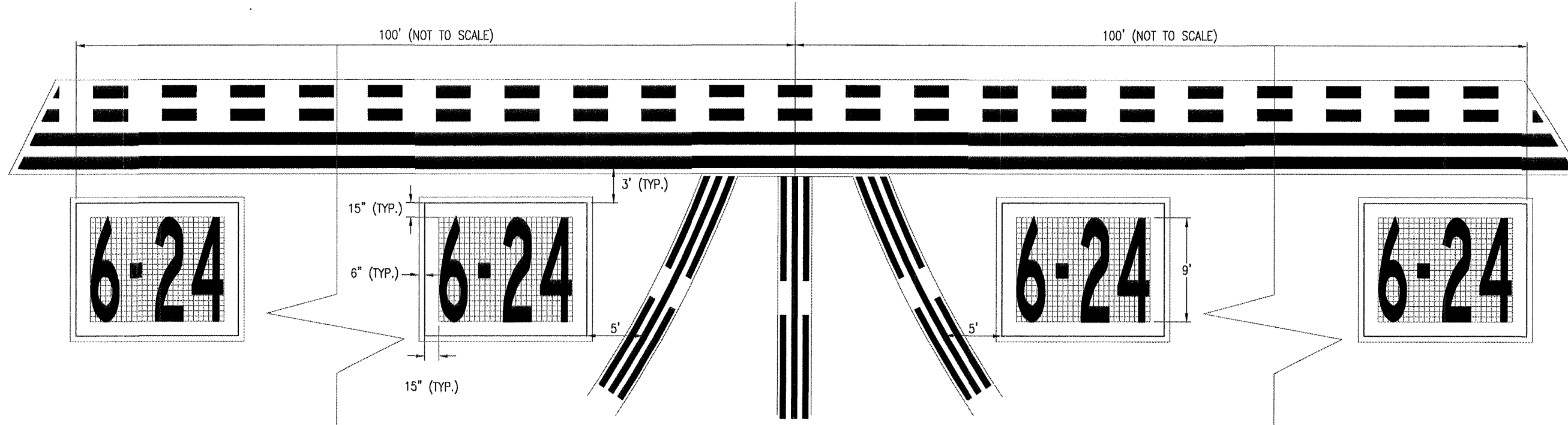

SURFACE PAINTED HOLDING POSITION SIGN DETAIL
 TAXIWAY F SHORT OF RUNWAY 6-24
 NOT TO SCALE

NOTE: GRID SHOWN FOR PROPER SIZING OF INSCRIPTIONS
 - NOT TO BE PAINTED. GRID SPACING IS 0.45 FEET.

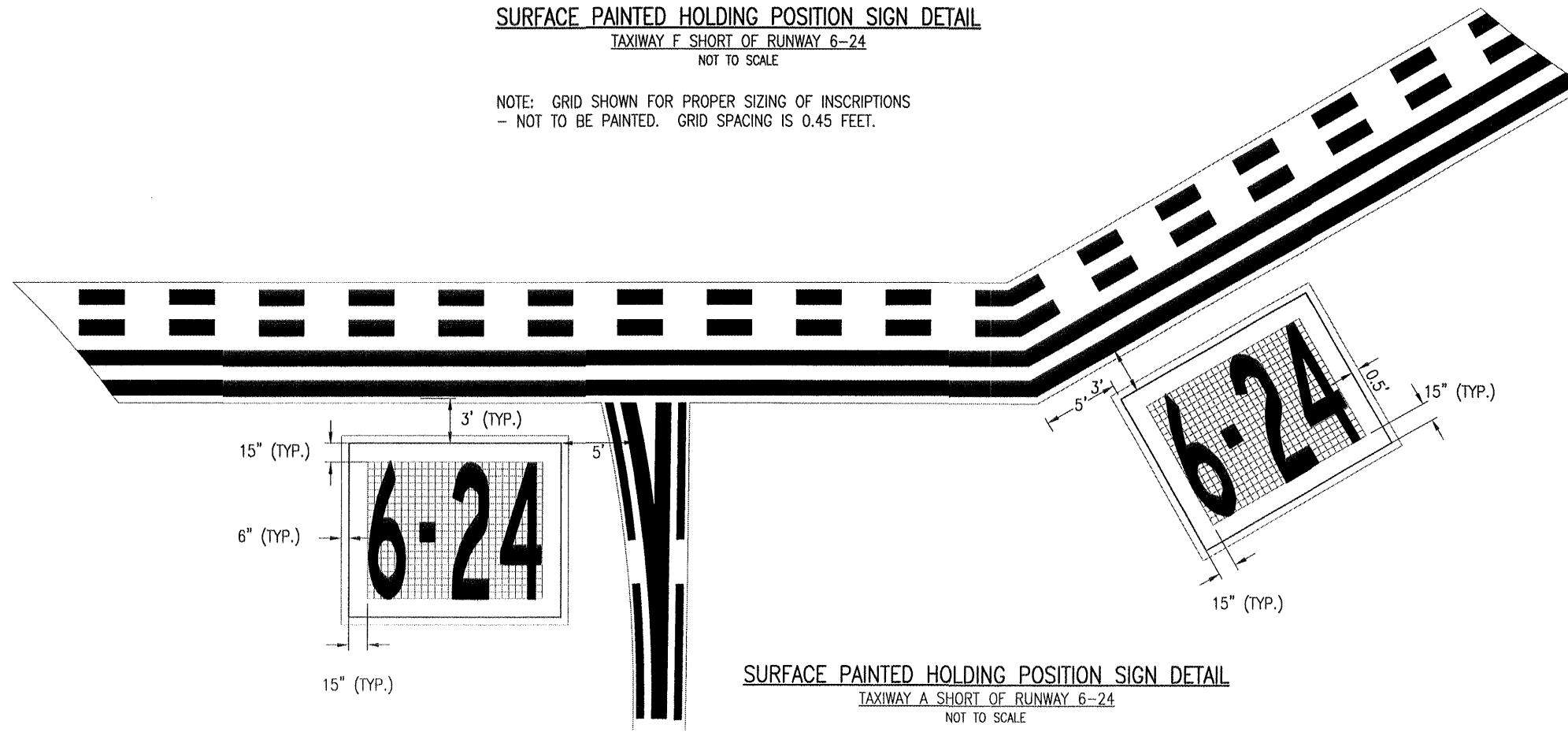

SURFACE PAINTED HOLDING POSITION SIGN DETAIL
 TAXIWAY A SHORT OF RUNWAY 6-24
 NOT TO SCALE

NOTE: GRID SHOWN FOR PROPER SIZING OF INSCRIPTIONS
 - NOT TO BE PAINTED. GRID SPACING IS 0.45 FEET.

| DATE | REVISION | BY |
|------|----------|----|
| | | |
| | | |
| | | |
| | | |
| | | |
| | | |
| | | |
| | | |
| | | |

SOUTHERN ILLINOIS AIRPORT
 MURPHYSBORO / CARBONDALE, ILLINOIS

SIA
 SOUTHERN ILLINOIS AIRPORT

IL PROJ.: MDH-3892 A.I.P. PROJ.: 3-17-0009-B29

| | | |
|----------------------------------|-----|----------|
| Hanson Project No. 0840067D_0800 | JSL | 04/03/09 |
| Filename: R-553MRK.DWG | JSL | 01/26/09 |
| Scale: NOT TO SCALE | CAH | 04/10/09 |
| Date: 01/26/09 | | |
| LAYOUT | | |
| DRAWN | | |
| REVIEWED | | |

HANSON

Hanson Professional Services Inc.
 1525 South Sixth Street
 Springfield, Illinois 62703-2986
 Offices Nationwide

REHABILITATE
 TAXIWAY "B"

PROPOSED SURFACE PAINTED
 HOLDING POSITION MARKING
 SIGN DETAILS

THE LOCATION, SIZE AND TYPE OF MATERIAL OF EXISTING UNDERGROUND UTILITIES INDICATED ON THE PLANS IS NOT REPRESENTED AS BEING ACCURATE, SUFFICIENT OR COMPLETE. IT SHALL BE THE CONTRACTOR'S RESPONSIBILITY TO DETERMINE THE ACTUAL LOCATION OF ALL SUCH FACILITIES, INCLUDING SERVICE CONNECTIONS TO UNDERGROUND UTILITIES. NEITHER THE OWNER OR THE ENGINEER ASSUMES ANY RESPONSIBILITY WHATSOEVER IN RESPECT TO THE ACCURACY OR SUFFICIENCY OF THE INFORMATION AND THERE IS NO GUARANTEE, EITHER EXPRESSED OR IMPLIED, THAT THE CONDITIONS INDICATED ARE REPRESENTATIVE OF THOSE TO BE ENCOUNTERED IN THE CONSTRUCTION. PRIOR TO CONSTRUCTION, THE CONTRACTOR SHALL NOTIFY THE UTILITY COMPANIES OF HIS OPERATIONAL PLANS AND SHALL OBTAIN FROM THE RESPECTIVE UTILITY COMPANIES DETAILED INFORMATION AND ASSISTANCE RELATIVE TO THE LOCATION OF THEIR FACILITIES AND THE WORKING SCHEDULE OF THE COMPANIES FOR REMOVAL OR ADJUSTMENT WHERE REQUIRED. IN THE EVENT AN UNEXPECTED UTILITY INTERFERENCE IS ENCOUNTERED DURING CONSTRUCTION, THE CONTRACTOR SHALL IMMEDIATELY NOTIFY THE UTILITY COMPANY OF JURISDICTION. THE ENGINEER SHALL ALSO BE IMMEDIATELY NOTIFIED. ANY SUCH MAINS AND SERVICES SHALL BE RESTORED TO SERVICE AT ONCE AND PAID FOR BY THE CONTRACTOR AT NO ADDITIONAL COST TO THE CONTRACT.

CALL J.U.L.I.E. FOR UTILITY INFORMATION AT 1-800-892-0123. CONTACT AIRPORT PERSONNEL FOR ASSISTANCE IN LOCATING AIRPORT CABLES. CONTACT FAA (FEDERAL AVIATION ADMINISTRATION) FOR ASSISTANCE IN LOCATING FAA CABLES.

NOTES:

- THE EXISTING TAXI GUIDANCE SIGNS (TO BE RELOCATED) SHALL BE REMOVED & STORED IN A SECURE LOCATION. THE EXISTING SIGN BASES WILL BE REMOVED AND DISPOSED OF OFF THE AIRPORT SITE IN A LEGAL MANNER. THE HOLES WILL BE FILLED WITH EARTH MATERIAL. NEW SIGN BASES SHALL BE CONSTRUCTED IN ACCORDANCE WITH THE DETAILS SHOWN ON THE ELECTRICAL DETAILS SHEET 1. THE STORED SIGNS SHALL BE INSTALLED ON THE NEW BASES. ANY DAMAGE TO THE SIGNS WILL BE REPAIRED OR REPLACED AT THE CONTRACTOR'S OWN EXPENSE. RESTORE, GRADE, SEED, & MULCH THE DISTURBED AREAS TO ESTABLISH A STAND OF GRASS. PAYMENT WILL BE MADE UNDER ITEM AR125964, RELOCATE TAXI GUIDANCE SIGN.
- THE EXISTING STAKE MOUNTED TAXIWAY LIGHT TO BE RELOCATED SHALL BE CONSTRUCTED IN ACCORDANCE WITH THE DETAILS SHOWN ON "ELECTRICAL DETAILS SHEET 2". PAYMENT WILL BE MADE UNDER ITEM AR125961 RELOCATE STAKE MOUNTED LIGHT.
- PER FAA AC 150/5340-30D DESIGN AND INSTALLATION DETAILS FOR AIRPORT VISUAL AIDS, A SAFETY GROUND MUST BE INSTALLED AT EACH LIGHT FIXTURE. A SAFETY GROUND SHALL BE INSTALLED AT EACH STAKE MOUNTED LIGHT AND EACH TRANSFORMER BASE/LIGHT CAN ASSOCIATED WITH RUNWAY LIGHTS, TAXIWAY LIGHTS, AND LIGHTED TAXI GUIDANCE SIGNS. THE SAFETY GROUND SHALL BE A #6 AWG BARE COPPER CONDUCTOR CONNECTED TO THE GROUND LUG ON THE RESPECTIVE L-867 TRANSFORMER BASE/LIGHT CAN OR MOUNTING STAKE AND A 3/8-INCH DIAMETER BY 8-FOOT LONG (MINIMUM) UL LISTED COPPER CLAD GROUND ROD. SEE ELECTRICAL DETAIL SHEETS FOR ADDITIONAL INFORMATION ON THIS REQUIREMENT.
- ALL TAXIWAY LIGHTS ARE TO BE LOCATED 10' FROM THE PAVEMENT EDGE, AND THE NEAR EDGE OF THE TAXIWAY SIGNS SHALL BE LOCATED 15' FROM THE EDGE OF PAVEMENT.
- REFER TO THE ELECTRICAL DETAILS SHEETS AND SPECIFICATIONS FOR DETAILS FOR THE STAKE AND BASE LIGHTS AND TAXIWAY SIGNS.
- LIGHTING CABLE SHALL BE 1/C No. 8, 5000 VOLT, FAA L-824. TYPE C UNDERGROUND CABLE IN UNIT DUCT. CABLE BENDS SHALL BE 3'-0" OR GREATER. CABLE IN UNIT DUCT SHALL BE INCIDENTAL TO THE RESPECTIVE AIRFIELD LIGHTING DEVICE RELOCATION OR TAXI GUIDANCE SIGN RELOCATION, AND NO ADDITIONAL COMPENSATION WILL BE MADE.
- LIGHTING CABLE SHALL BE BURIED AT A MINIMUM DEPTH OF 18 INCHES AND 12 FEET FROM THE PAVEMENT EDGE. THE SPACING OF MULTI CABLES IN THE SAME TRENCH SHALL BE SEPARATED BY 3 INCHES, CABLE TO CABLE. FOR ELECTRICAL TRENCH DETAILS REFER TO TO THE ELECTRICAL DETAILS SHEET 25.
- IN AREAS WHERE THERE IS A CONGESTION OF EXISTING CABLES, THE PROPOSED CABLES SHALL BE HAND-DUG IN PLACE. AT ALL OTHER LOCATIONS, THE CABLE MAY BE TRENCHED OR PLOWED INTO PLACE.
- THE CONCRETE USED IN THE CONSTRUCTION OF THESE ITEMS SHALL BE IN ACCORDANCE WITH ITEM 610.
- PRIOR TO INSTALLING THE PROPOSED TAXIWAY LIGHTS OR TAXI GUIDANCE SIGNS, THE CONTRACTOR SHALL APPLY AN OXIDE-INHIBITING, ANTI-SEIZING COMPOUND TO ALL SCREWS, NUTS, BREAKABLE COUPLING, AND ALL PLACES WHERE METAL COMES INTO CONTACT WITH METAL. THE ANTI-SEIZE COMPOUND SHALL BE AS MANUFACTURED BY I.T.T. BRAND NAME "CONTAX" OR APPROVED EQUAL.
- ALL BASE PLATE MOUNTING BOLTS AND STAKE MOUNTING BOLTS SHALL BE STAINLESS STEEL.
- THE CONTRACTOR SHALL LOCATE ALL BURIED CABLES PRIOR TO THE PLACEMENT OF NEW CABLES. IN AREAS OF MULTIPLE CABLES, THE PROPOSED CABLES SHALL BE PLACED BY HAND DIGGING.

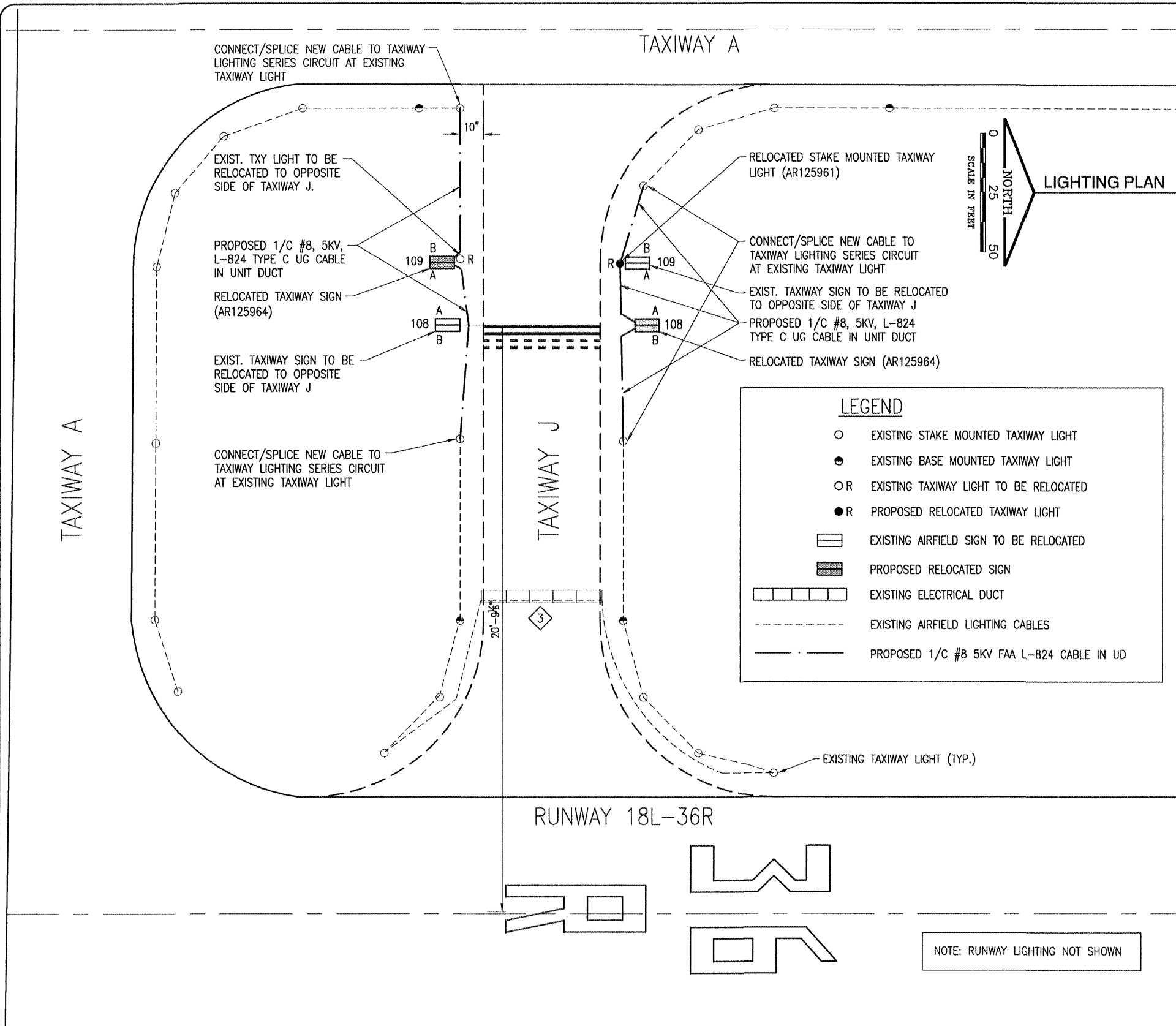

NOTE: RUNWAY LIGHTING NOT SHOWN

| RELOCATED SIGN SCHEDULE | | | | | |
|-------------------------|-----------|-------------------|----------------|------------------|----------------------------|
| SIGN NO. | SIGN FACE | SIGN PANEL COLORS | NO. OF MODULES | SIGN DESCRIPTION | REMARKS |
| 108 | A | L/R/R/R | 4 | J 18 L-3 6R | EXISTING SIGN 8-CHARACTERS |
| 109 | A | L/Y/Y | 3 | J A → | EXISTING SIGN 3-CHARACTERS |

| DATE | REVISION | BY |
|------|----------|----|
| | | |
| | | |
| | | |

SOUTHERN ILLINOIS AIRPORT
MURPHYSBORO / CARBONDALE, ILLINOIS

SIA
SOUTHERN ILLINOIS AIRPORT

IL PROJ.: MDH-3692 A.I.P. PROJ.: 3-17-0009-B29

| | | | |
|-------------------------------------|----------------------|---------------|----------------|
| Revision: Project No. 08A0067D-0800 | File Name: E-101.DWG | Scale: 1"=25' | Date: 01/26/09 |
| LAYOUT | KNL | 03/27/09 | 03/27/09 |
| DRAWN | MV | 03/27/09 | 03/27/09 |
| REVIEWED | CAH | 04/10/09 | 04/10/09 |

HANSON

Hanson Professional Services Inc.
1525 South Sixth Street
Springfield, Illinois 62703-2886
Offices Nationwide

REHABILITATE TAXIWAY "B"
TAXIWAY SIGNS & LIGHT RELOCATIONS

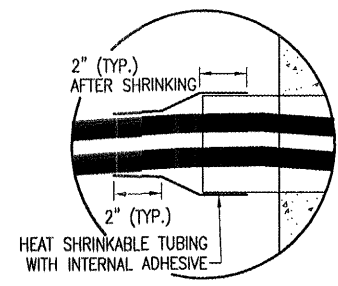

DETAIL "B"
(NOT TO SCALE)

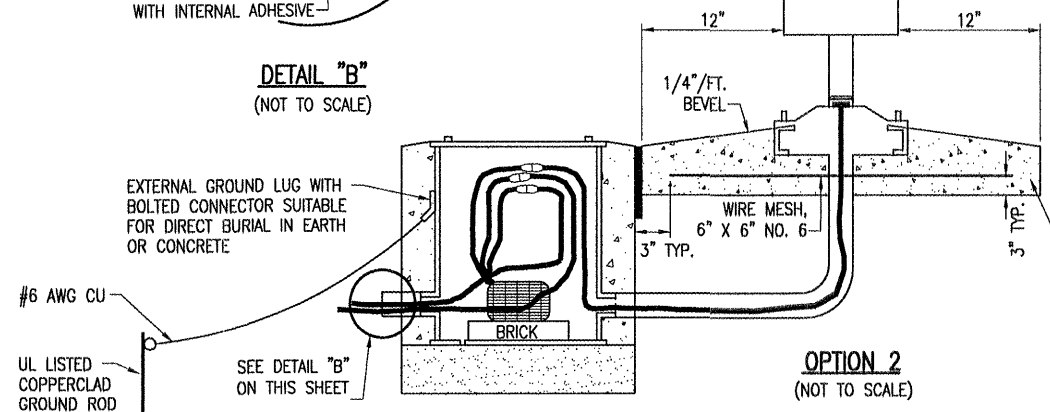

OPTION 2
(NOT TO SCALE)

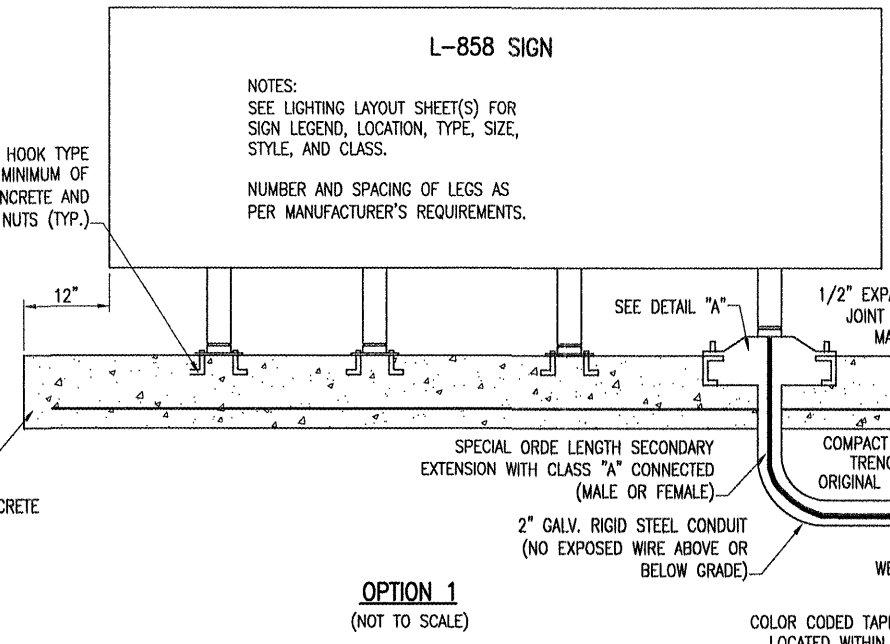

OPTION 1
(NOT TO SCALE)

THE LOCATION OF UNDERGROUND UTILITIES AS INDICATED ON THE PLANS HAS BEEN OBTAINED FROM EXISTING RECORDS. NEITHER THE OWNER NOR THE ENGINEER ASSUMES ANY RESPONSIBILITY WHATSOEVER, IN RESPECT TO THE ACCURACY OR SUFFICIENCY OF THE INFORMATION AND THERE IS NO GUARANTEE, EITHER EXPRESSED OR IMPLIED, THAT THE CONDITIONS ARE REPRESENTATIVE OF THOSE TO BE ENCOUNTERED IN THE CONSTRUCTION.

L-858 SIGN
NOTES:
SEE LIGHTING LAYOUT SHEET(S) FOR SIGN LEGEND, LOCATION, TYPE, SIZE, STYLE, AND CLASS.
NUMBER AND SPACING OF LEGS AS PER MANUFACTURER'S REQUIREMENTS.

GENERAL NOTES

SEE LIGHTING LAYOUT SHEET FOR SIGN LEGEND, LOCATION, TYPE, SIZE, AND CLASS.
SEE ELECTRICAL NOTES SHEET 26 & 27.

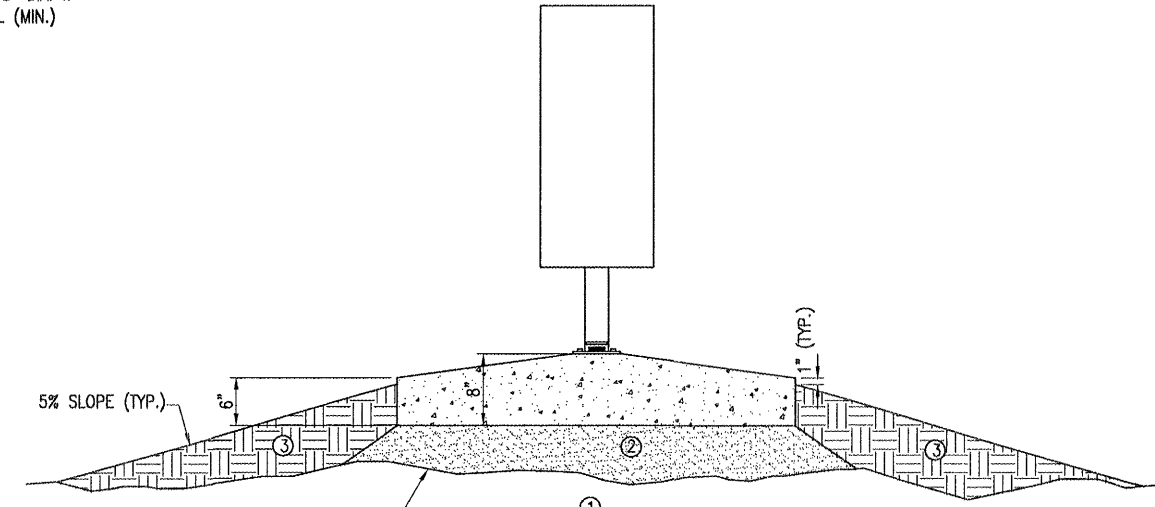

SIGN DETAIL
(NOT TO SCALE)

- ① EXISTING SOD TO BE STRIPPED AND REMOVED
- ② SAND BACKFILL, VARIABLE DEPTH
- ③ PROPOSED TOPSOIL BACKFILL MATERIAL

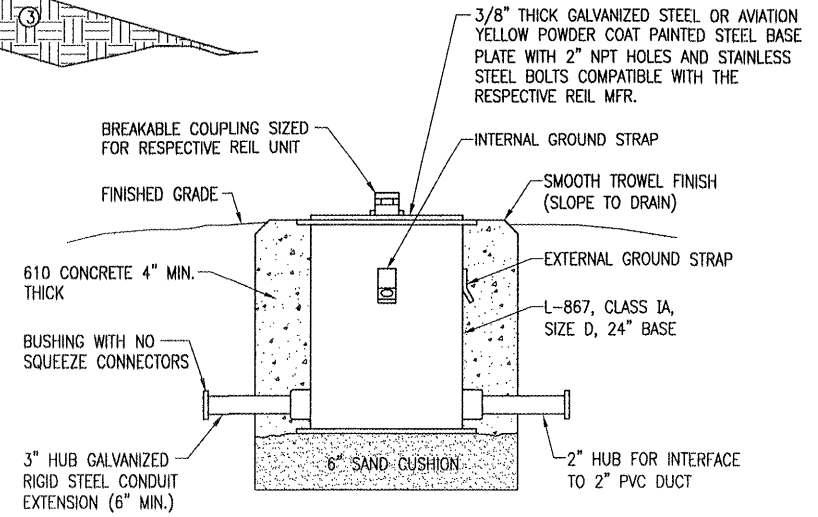

REIL BASE DETAIL
(NOT TO SCALE)

NOTE:
FOR THE PURPOSE OF ENHANCING SAFETY, EACH BASE MUST HAVE INSTALLED, BY THE MANUFACTURER, AN INTERNAL AND EXTERNAL GROUND STRAP THAT IS AVAILABLE FOR THE PURPOSE OF ATTACHING A GROUND LUG THAT IS CONNECTED TO AN EARTH GROUND OR A SAFETY GROUND CONDUCTOR INSTALLED WITH THE RESPECTIVE CIRCUIT. FOR AIRPORT PROJECTS RECEIVING FEDERAL FUNDS THIS REQUIREMENT IS MANDATORY PER FAA AC 150/5345-42F.

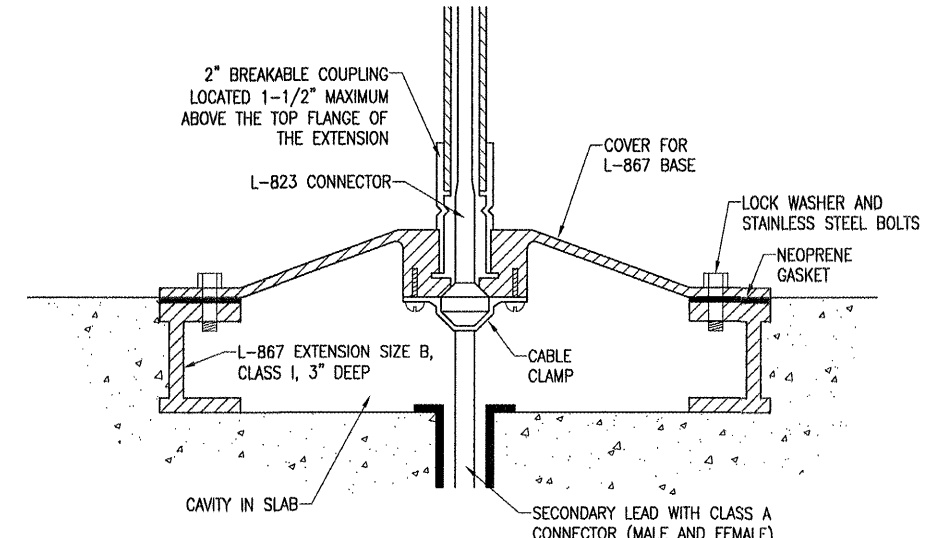

DETAIL "A"
(NOT TO SCALE)

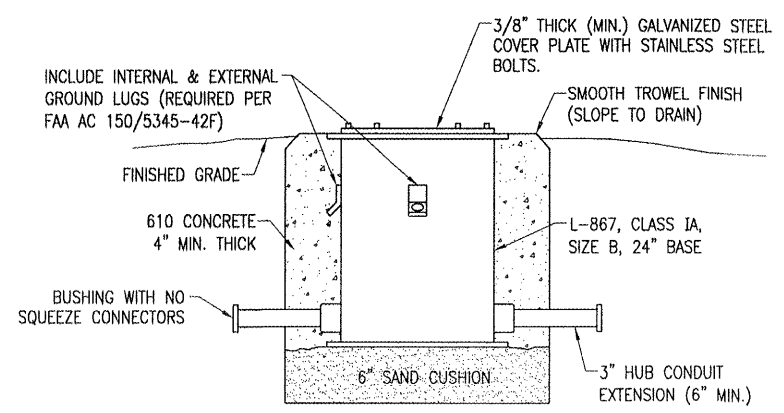

TRANSFORMER BASE/SPLICE CAN DETAIL
(NOT TO SCALE)

PER FAA AC 150/5340-30C DESIGN AND INSTALLATION DETAILS FOR AIRPORT VISUAL AIDS, A SAFETY GROUND MUST BE INSTALLED AT EACH LIGHT FIXTURE. A SAFETY GROUND SHALL BE INSTALLED AT EACH STAKE MOUNTED LIGHT AND EACH TRANSFORMER BASE/LIGHT CAN ASSOCIATED WITH RUNWAY LIGHTS, TAXIWAY LIGHTS, AND LIGHTED TAXI GUIDANCE SIGNS. THE SAFETY GROUND SHALL BE A #6 AWG BARE COPPER CONDUCTOR CONNECTED TO THE GROUND LUG ON THE RESPECTIVE L-867 TRANSFORMER BASE/LIGHT CAN OR MOUNTING STAKE AND A 3/8-INCH DIAMETER BY 8-FOOT LONG (MINIMUM) UL LISTED COPPER CLAD GROUND ROD.

| REVISION | DATE | BY |
|----------|------|----|
| | | |
| | | |
| | | |
| | | |

SOUTHERN ILLINOIS AIRPORT
MURPHYSBORO / CARBONDALE, ILLINOIS

SIA
SOUTHERN ILLINOIS AIRPORT

IL PROJ.: MDH-3892 A.I.P. PROJ.: 3-17-0009-B29

| | | | |
|----------------------------------|-----------------------|--------------------|---------------|
| Hanson Project No. 08A0067D-0800 | Filename R-541ELE.DWG | Scale NOT TO SCALE | Date 01/26/09 |
| LAYOUT | KNL | 01/26/09 | 01/26/09 |
| DRAWN | MV | 01/26/09 | 01/26/09 |
| REVIEWED | CAH | 04/10/09 | 04/10/09 |

HANSON
Hanson Professional Services Inc.
1525 South Sixth Street
Springfield, Illinois 62703-2886
Offices Nationwide

REHABILITATE TAXIWAY "B"
ELECTRICAL DETAILS
SHEET 1

MAY 12, 2009 11:47 AM KINCA00394 I:\AIRPORTS\SA-CARBONDALE\08A0067\CADD\AIRPORT SHEET\B-541ELE.DWG - Work

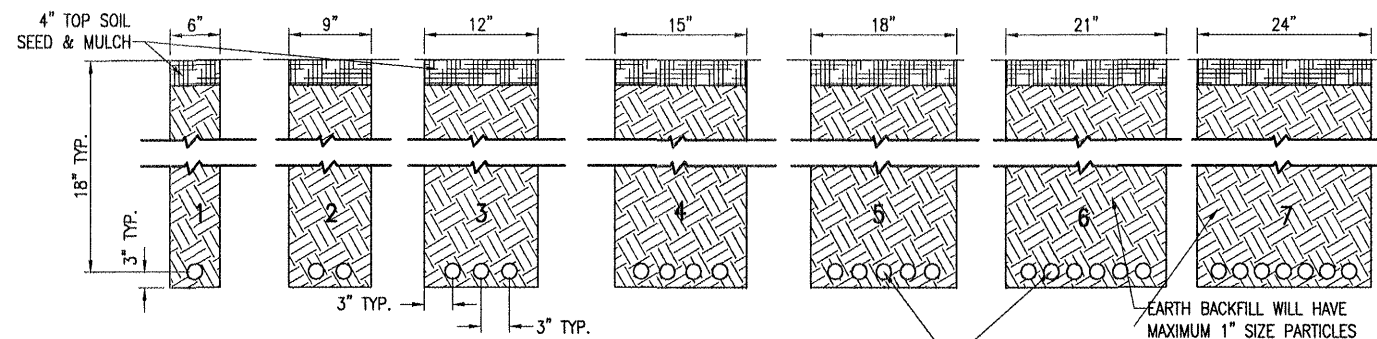

NOTES:
 DETAIL NUMBERS INDICATE NO. OF CABLES.
 TRENCHES WITH MORE THAN SEVEN CABLES SHALL BE INCREASED 3" IN WIDTH FOR EACH ADDITIONAL CABLE; IF SPECIFIED ON PLANS TWO PARALLEL TRENCHES MAY BE CONSTRUCTED.
 DEPTH OF TRENCHES SHALL BE AS SHOWN ABOVE UNLESS OTHERWISE SPECIFIED ON THE PLANS.
 ALL DISTURBED SURFACES SHALL BE RESTORED TO THEIR ORIGINAL CONDITION. COST IS INCIDENTAL TO TRENCH.

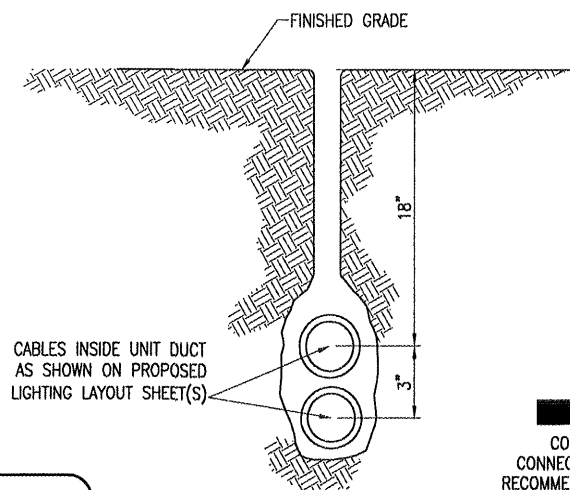

PLOWED CABLE
(NOT TO SCALE)

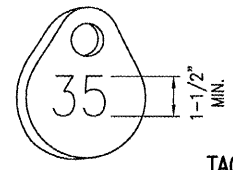

TAG DETAIL
(NOT TO SCALE)

NOTE:
 AFFIX NON-CORROSIVE TAG TO FIXTURE FACING RUNWAY WITH SET SCREW, WIRE TIE, OR METAL BAND. NUMERALS SHALL BE ENGRAVED FOR PERMANENT READABILITY.

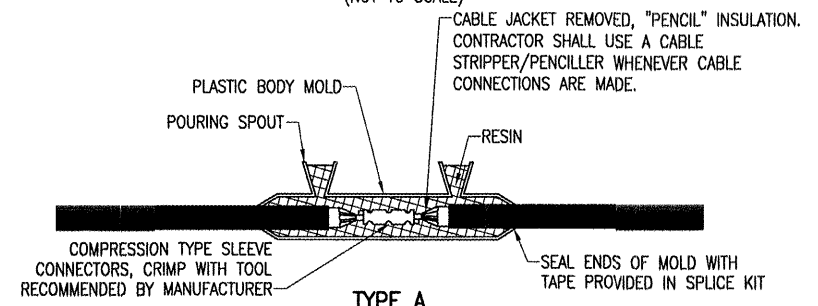

TYPE A

FOR SPLICES IN HOMERUNS FOR EXTENSIONS TO EXISTING CABLES ONLY

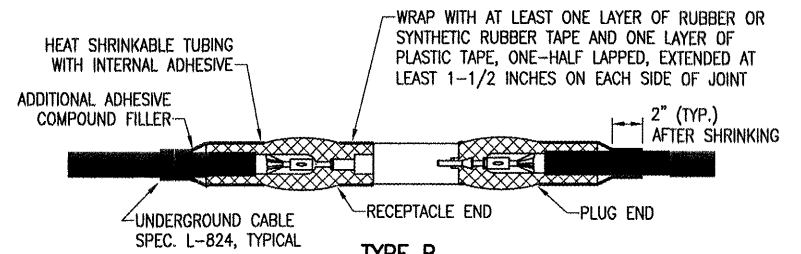

TYPE B

FOR SPLICES AT JUNCTION OF HOMERUN WITH LOOP CIRCUIT

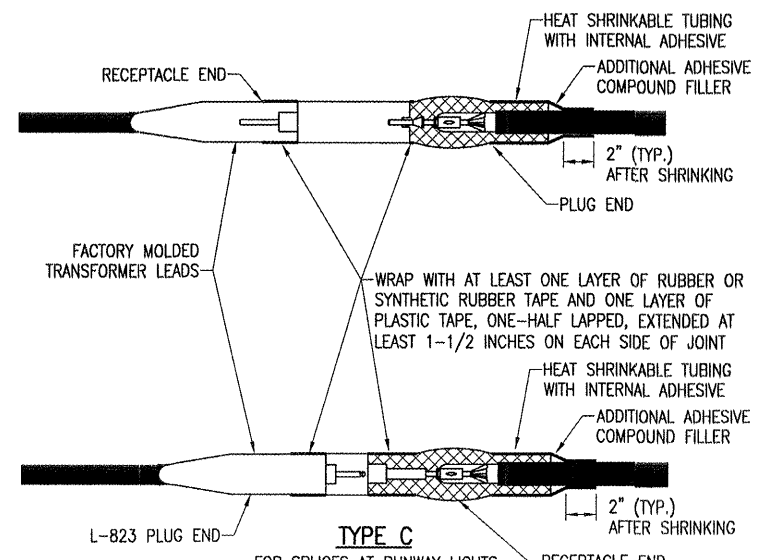

TYPE C

FOR SPLICES AT RUNWAY LIGHTS

CABLE SPLICES
(NOT TO SCALE)

NOTES:
 SEE PROPOSED LIGHTING LAYOUT SHEET(S) FOR SPLICE TYPE.
 INSIDE DIAMETER OF CONNECTOR SHALL PROPERLY MATCH THE OUTSIDE DIAMETER OF CABLE.

PER FAA AC 150/5340-30C DESIGN AND INSTALLATION DETAILS FOR AIRPORT VISUAL AIDS, A SAFETY GROUND MUST BE INSTALLED AT EACH LIGHT FIXTURE. A SAFETY GROUND SHALL BE INSTALLED AT EACH STAKE MOUNTED LIGHT AND EACH TRANSFORMER BASE/LIGHT CAN ASSOCIATED WITH RUNWAY LIGHTS, TAXIWAY LIGHTS, AND LIGHTED TAXI GUIDANCE SIGNS. THE SAFETY GROUND SHALL BE A #6 AWG BARE COPPER CONDUCTOR CONNECTED TO THE GROUND LUG ON THE RESPECTIVE L-867 TRANSFORMER BASE/LIGHT CAN OR MOUNTING STAKE AND A 3/8-INCH DIAMETER BY 8-FOOT LONG (MINIMUM) UL LISTED COPPER CLAD GROUND ROD.

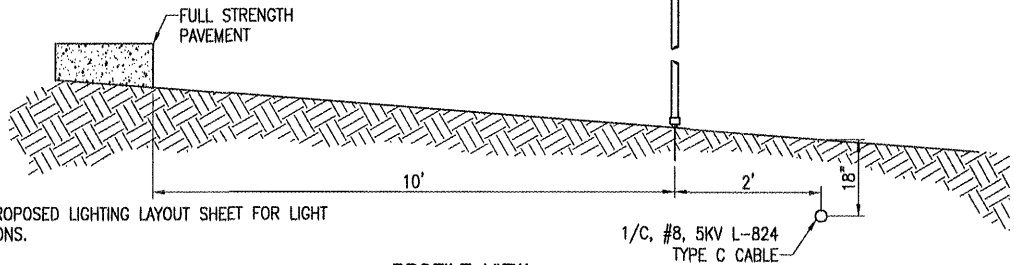

PROFILE VIEW

CABLE TRENCHES
(NOT TO SCALE)

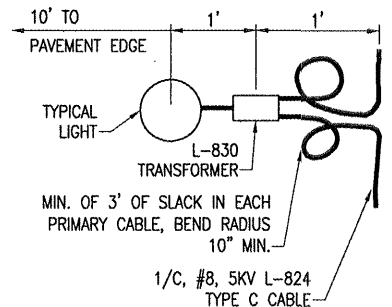

PLAN VIEW

LIGHT AND CABLE INSTALLATION DETAIL
(NOT TO SCALE)

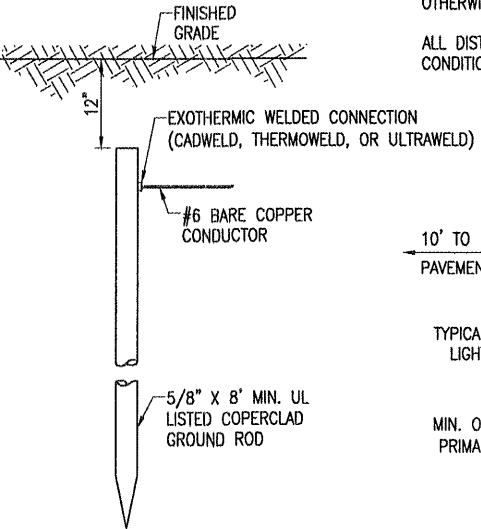

NOTES:
 TYPE AND MINIMUM NUMBER OF GROUND RODS SHALL BE AS SPECIFIED ON THE PLAN.
 THE RESISTANCE TO GROUND OF THE GROUNDING SYSTEM SHALL NOT EXCEED 25 OHMS.
 COST OF GROUND RODS IS INCIDENTAL TO THE ASSOCIATED ITEMS REQUIRING GROUNDING UNLESS OTHERWISE SPECIFIED.

GROUND ROD
(NOT TO SCALE)

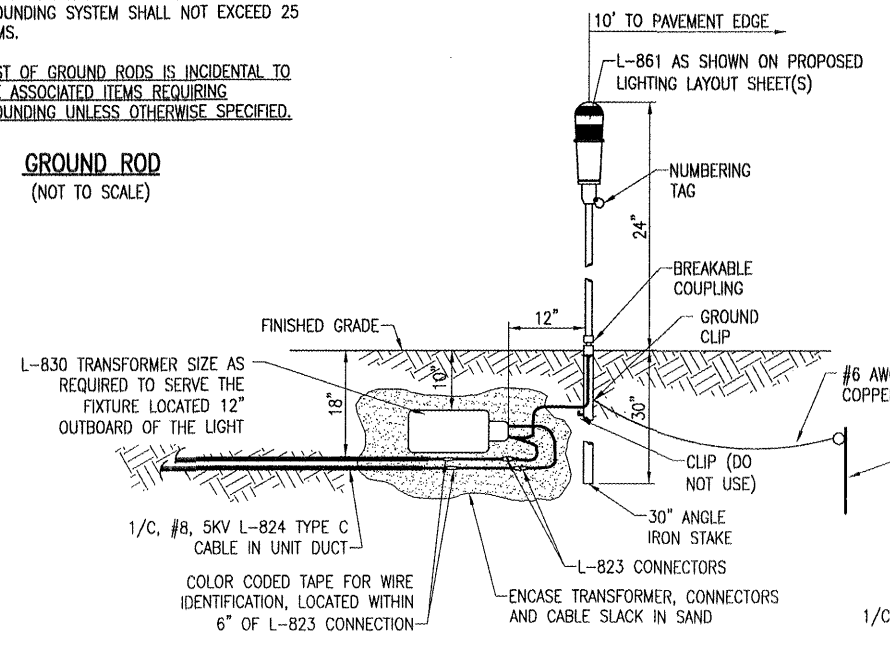

MEDIUM INTENSITY LIGHT - STAKE MOUNTED
(NOT TO SCALE)

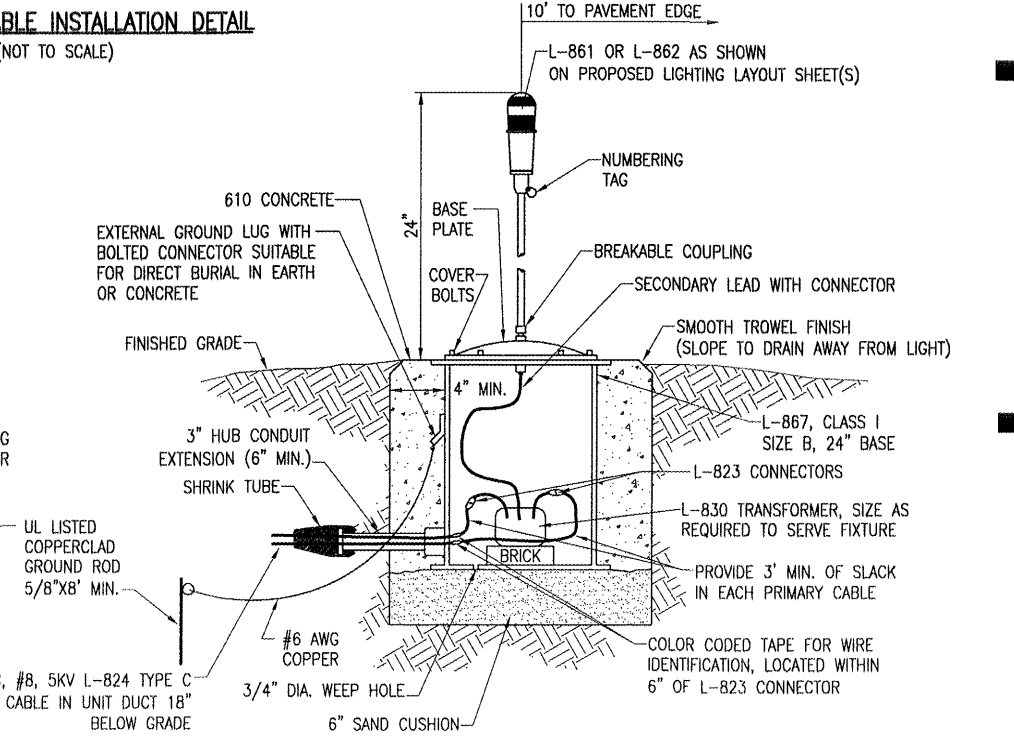

MEDIUM/HIGH INTENSITY LIGHT - BASE MOUNTED
(NOT TO SCALE)

| | |
|----------|--|
| BY | |
| REVISION | |
| DATE | |

SOUTHERN ILLINOIS AIRPORT
 MURPHYSBORO / CARBONDALE, ILLINOIS

| | |
|----------|----------|
| Revision | 01/26/09 |
| Drawn | MV |
| Checked | CAH |
| Approved | |

HANSON
 Hanson Professional Services Inc.
 1024 South State Street
 Springfield, Illinois 62703-2886
 Offices Nationwide

REHABILITATE
 TAXIWAY "B"
 ELECTRICAL DETAILS
 SHEET 2

MAY 12, 2009 11:48 AM KINCADD394 I:\AIRPORTS\SIA-CARBONDALE\08A0067\CADD\AIRPORT\SHEET\R-542ELE.DWG - Work

GENERAL NOTES

- 1. ALL ELECTRICAL EQUIPMENT SHALL BE INSTALLED IN CONFORMANCE WITH NFPA 70 - NATIONAL ELECTRICAL CODE (NEC) MOST CURRENT ISSUE IN FORCE, THE RESPECTIVE EQUIPMENT MANUFACTURER'S DIRECTIONS AND ALL OTHER APPLICABLE LOCAL CODES, LAWS, ORDINANCES, AND REQUIREMENTS IN FORCE. ANY INSTALLATIONS WHICH VOID THE U.L. LISTING, ETL LISTING (OR OTHER THIRD PARTY LISTING) AND/OR THE MANUFACTURER'S WARRANTY OF A DEVICE WILL NOT BE PERMITTED.
2. CONTRACTOR SHALL KEEP A COPY OF THE LATEST NEC IN FORCE ON SITE AT ALL TIMES DURING CONSTRUCTION FOR USE AS A REFERENCE.
3. CONTRACTOR SHALL COORDINATE WORK AND ANY POWER OUTAGES AND/OR SHUT DOWN OF SYSTEMS WITH THE RESPECTIVE FACILITY OWNER PERSONNEL AND THE AIRPORT MANAGER/DIRECTOR. ONCE SHUT DOWN, THE CIRCUITS SHALL BE LABELED AS SUCH TO PREVENT ACCIDENTAL ENERGIZING OF THE RESPECTIVE CIRCUITS. ALL PERSONNEL SHALL FOLLOW U.S. DEPARTMENT OF LABOR OCCUPATIONAL SAFETY & HEALTH ADMINISTRATION (OSHA) 29 CFR PART 1910 OCCUPATIONAL SAFETY & HEALTH STANDARDS FOR ELECTRICAL SAFETY AND LOCKOUT/TAGOUT PROCEDURES INCLUDING, BUT NOT LIMITED TO, 29 CFR SECTION 1910.147 THE CONTROL OF HAZARDOUS ENERGY (LOCKOUT/TAGOUT).
4. THE CONTRACTOR SHALL ASCERTAIN THAT ALL LIGHTING SYSTEM COMPONENTS FURNISHED BY HIM, INCLUDING FAA APPROVED EQUIPMENT, ARE COMPATIBLE IN ALL RESPECTS WITH EACH OTHER AND THE REMAINDER OF THE NEW/EXISTING SYSTEM. ANY NONCOMPATIBLE COMPONENTS FURNISHED BY THIS CONTRACTOR SHALL BE REPLACED BY HIM AT NO ADDITIONAL COST TO THE AIRPORT SPONSOR WITH A SIMILAR UNIT, APPROVED BY THE ENGINEER (DIFFERENT MODEL OR DIFFERENT MANUFACTURER) THAT IS COMPATIBLE WITH THE REMAINDER OF THE AIRPORT LIGHTING SYSTEM.
5. IN CASE THE CONTRACTOR ELECTS TO FURNISH AND INSTALL AIRPORT LIGHTING EQUIPMENT REQUIRING ADDITIONAL WIRING, TRANSFORMERS, ADAPTORS, MOUNTINGS, ETC., TO THOSE SHOWN ON THE DRAWINGS AND/OR LISTED IN THE SPECIFICATION, ANY COST FOR THESE ITEMS SHALL BE INCIDENTAL TO THE EQUIPMENT COST.
6. THE CONTRACTOR INSTALLED EQUIPMENT (INCLUDING FAA APPROVED) SHALL NOT GENERATE ANY ELECTROMAGNETIC INTERFERENCE IN THE EXISTING AND/OR NEW COMMUNICATIONS, WEATHER, AIR NAVIGATION, AND AIR TRAFFIC CONTROL EQUIPMENT. ANY EQUIPMENT GENERATING SUCH INTERFERENCE SHALL BE REPLACED BY THE CONTRACTOR AT NO ADDITIONAL COST WITH THE EQUIPMENT MEETING THE APPLICABLE SPECIFICATIONS AND NOT GENERATING ANY INTERFERENCE.
7. WHEN A SPECIFIC TYPE, STYLE, CLASS, ETC. OF FAA APPROVED EQUIPMENT IS SPECIFIED ONLY THAT TYPE, STYLE, CLASS, WILL BE ACCEPTABLE, EVEN THOUGH EQUIPMENT OF OTHER TYPES STYLES, CLASSES, ETC. MAY BE APPROVED.
8. ANY AND ALL INSTRUCTIONS FROM THE ENGINEER TO THE CONTRACTOR REGARDING CHANGES IN OR DEVIATIONS FROM THE PLANS AND SPECIFICATIONS SHALL BE IN WRITING WITH COPIES SENT TO THE AIRPORT SPONSOR AND THE FAA FIELD OFFICE (ADO/AFO). THE CONTRACTOR SHALL NOT ACCEPT ANY VERBAL INSTRUCTIONS FROM THE RESIDENT ENGINEER REGARDING ANY CHANGES FROM THE PLANS AND SPECIFICATIONS.
9. A MINIMUM OF THREE COPIES OF THE INSTRUCTION BOOK SHALL BE SUPPLIED WITH EACH DIFFERENT TYPE OF EQUIPMENT. THE BOOKS DESCRIBING A MORE SOPHISTICATED TYPE OF EQUIPMENT, SUCH AS REGULATORS, PAPI, REIL, ETC. AS A MINIMUM SHALL CONTAIN THE FOLLOWING:
A. A DETAILED DESCRIPTION OF THE OVERALL EQUIPMENT AND ITS INDIVIDUAL COMPONENTS.
B. THEORY OF OPERATION INCLUDING THE FUNCTION OF EACH COMPONENT.
C. INSTALLATION INSTRUCTION.
D. START-UP INSTRUCTIONS.
E. PREVENTATIVE MAINTENANCE REQUIREMENTS.
F. CHART FOR TROUBLE-SHOOTING.
G. COMPLETE POWER AND CONTROL DETAILED WIRING DIAGRAM(S), SHOWING EACH CONDUCTOR/CONNECTION/COMPONENT - "BLACK" BOXES ARE NOT ACCEPTABLE. THE DIAGRAM OF THE NARRATIVE SHALL SHOW VOLTAGE/CURRENTS/WAVE SHAPES AT STRATEGIC LOCATIONS TO BE USED WHEN CHECKING AND/OR TROUBLE-SHOOTING THE EQUIPMENT. WHEN THE EQUIPMENT HAS SEVERAL MODES OF OPERATION, SUCH AS SEVERAL BRIGHTNESS STEPS, THESE PARAMETERS SHALL BE INDICATED FOR ALL DIFFERENT MODES.
H. PARTS LIST WHICH WILL INCLUDE ALL MAJOR AND MINOR COMPONENTS SUCH AS RESISTORS, DIODES, ETC. IT SHALL INCLUDE A COMPLETE NOMENCLATURE OF EACH COMPONENT AND, IF APPLICABLE, THE NAME OF ITS MANUFACTURER AND THE CATALOG NUMBER.
I. SAFETY INSTRUCTIONS.

POWER AND CONTROL NOTES

- 1. PROVIDE LEGEND PLATES FOR ALL ELECTRICAL EQUIPMENT TO IDENTIFY FUNCTION, CIRCUIT VOLTAGE AND PHASE. WHERE THE EQUIPMENT CONTAINS FUSES, ALSO IDENTIFY THE FUSE OR FUSE LINK AMPERE RATING. WHERE THE EQUIPMENT DOES NOT HAVE SUFFICIENT AREA TO INSTALL LEGEND PLATES, THE LEGEND PLATES SHALL BE INSTALLED ON THE WALL NEXT TO THE UNIT. LEGEND PLATES SHALL BE WEATHERPROOF ENGRAVED PLASTIC OR PHENOLIC MATERIAL, 1/4" HIGH BLACK LETTERS ON A WHITE BACKGROUND UNLESS NOTED OTHERWISE. SECURE WITH WEATHERPROOF ADHESIVE AND MACHINE SCREWS. FURNISH ADDITIONAL LEGEND PLATES WHERE REQUIRED BY CODE, FOR ADDITIONAL EQUIPMENT, AS DETAILED HEREIN ON THE PLANS, AND AS NOTED IN THE SPECIAL PROVISION SPECIFICATIONS.
2. COLOR CODE ALL PHASE WIRING BY THE USE OF COLORED WIRE INSULATION AND/OR COLORED TAPE. WHERE TAPE IS USED, THE WIRE INSULATION SHALL BE BLACK. BLACK AND RED SHALL BE USED FOR SINGLE-PHASE, THREE WIRE SYSTEMS AND BLACK, RED AND BLUE SHALL BE USED FOR THREE-PHASE SYSTEMS. NEUTRAL CONDUCTORS, SIZE NO. 6 AWG OR SMALLER, SHALL BE IDENTIFIED BY A CONTINUOUS WHITE OR NATURAL GRAY OUTER FINISH ALONG ITS ENTIRE LENGTH. NEUTRAL CONDUCTORS LARGER THAN NO. 6 AWG SHALL BE IDENTIFIED EITHER BY A CONTINUOUS WHITE OR NATURAL GRAY OUTER FINISH ALONG ITS ENTIRE LENGTH OR BY THE USE OF WHITE TAPE AT ITS TERMINATIONS AND INSIDE ACCESSIBLE WIREWAYS. INSULATED GROUND CONDUCTORS SHALL HAVE GREEN COLORED INSULATION FOR ALL CONDUCTOR SIZES (AWG OR KCMIL).
3. ALL BRANCH CIRCUIT CONDUCTORS CONNECTED TO A PARTICULAR PHASE SHALL BE IDENTIFIED WITH THE SAME COLOR. THE COLOR CODING SHALL BE EXTENDED TO THE POINT OF UTILIZATION.
4. IN CONTROL WIRING THE SAME COLOR SHALL BE USED THROUGHOUT THE SYSTEM FOR THE SAME FUNCTION, SUCH AS 10%, 30%, 100% BRIGHTNESS CONTROL, ETC.
5. LOW VOLTAGE (600 V.) AND HIGH VOLTAGE (5000 V.) CONDUCTORS SHALL BE INSTALLED IN SEPARATE WIREWAYS.
6. NEATLY LACE WIRING IN DISTRIBUTION PANELS, WIREWAYS, SWITCHES AND JUNCTION/PULL BOXES.
7. THE MINIMUM SIZE OF PULL/JUNCTION BOXES, REGARDLESS OF THE QUANTITY AND SIZE OF THE CONDUCTORS SHOWN, SHALL BE AS FOLLOWS:
A. IN STRAIGHT PULLS THE LENGTH OF THE BOX SHALL NOT BE LESS THAN EIGHT TIMES THE TRADE DIAMETER OF THE LARGER CONDUIT. THE TOTAL AREA (INCLUDING THE CONDUIT CROSS-SECTIONAL AREA) OF A BOX END SHALL BE AT LEAST 3 TIMES GREATER THAN THE TOTAL TRADE CROSS-SECTIONAL AREA OF THE CONDUITS TERMINATING AT THE END.
B. IN ANGLE PULLS OR 'U' PULLS THE DISTANCE BETWEEN EACH CONDUIT ENTRY INSIDE THE BOX AND THE OPPOSITE WALL OF THE BOX SHALL NOT BE LESS THAN SIX (6) TIMES THE TRADE DIAMETER OF THE LARGEST CONDUIT. THIS DISTANCE SHALL BE INCREASED FOR ADDITIONAL ENTRIES BY THE AMOUNT OF THE SUM OF THE DIAMETERS OF ALL OTHER CONDUIT ENTRIES ON THE SAME WALL AS THE BOX. THE DISTANCE BETWEEN CONDUIT ENTRIES ENCLOSING THE SAME CONDUCTOR SHALL NOT BE LESS THAN SIX TIMES THE TRADE DIAMETER OF THE LARGEST CONDUIT.
8. A RUN OF CONDUIT BETWEEN TERMINATIONS AT EQUIPMENT ENCLOSURES, SQUARE DUCTS AND PULL/JUNCTION BOXES, SHALL NOT CONTAIN MORE THAN THE EQUIVALENT OF FOUR QUARTER BENDS (360 DEGREES TOTAL), INCLUDING THOSE BENDS LOCATED IMMEDIATELY AT THE TERMINATIONS, CAST, CONDUIT TYPE OUTLETS SHALL NOT BE TREATED AS PULL/JUNCTION BOXES.
9. EQUIPMENT CABINETS SHALL NOT BE USED AS PULL/JUNCTION BOXES. ONLY WIRING TERMINATING AT THE EQUIPMENT SHALL BE BROUGHT INTO THESE ENCLOSURES.
10. SPLICES AND JUNCTION POINTS SHALL BE PERMITTED ONLY IN JUNCTION BOXES, DUCTS EQUIPPED WITH REMOVABLE COVERS, AND AT EASILY ACCESSIBLE LOCATIONS.
11. CIRCUIT BREAKERS IN POWER DISTRIBUTION PANEL(S) SHALL BE THERMAL-MAGNETIC MOLDED CASE, PERMANENT TRIP WITH 100 AMPERE, MINIMUM FRAME.
12. DUAL LUGS SHALL BE USED WHERE TWO (2) WIRES, SIZE NO. 6 OR LARGER, ARE TO BE CONNECTED TO THE SAME TERMINAL.
13. ALL INTERIOR WALL MOUNTED EQUIPMENT ENCLOSURES SHALL BE MOUNTED ON HOT DIPPED GALVANIZED STEEL STRUT SUPPORT, OR STAINLESS STEEL STRUT SUPPORT, WITH CORROSION RESISTANT HARDWARE.
14. SUPPORT FOR EXTERIOR MOUNTED EQUIPMENT SHALL USE HOT DIPPED GALVANIZED STEEL STRUT SUPPORT OR STAINLESS STEEL STRUT SUPPORT WITH STAINLESS STEEL HARDWARE. PROVIDE ZINC RICH PAINT APPLIED TO FIELD CUTS OF GALVANIZED STEEL SUPPORT TO MINIMIZE THE POTENTIAL FOR CORROSION PER THE RESPECTIVE STRUT SUPPORT MANUFACTURER'S RECOMMENDATIONS.

- 15. CONDUITS FOR ELECTRIC SERVICE ENTRANCE AND FEEDERS SHALL BE AS DETAILED HEREIN ON THE PLANS. WHERE GALVANIZED RIGID STEEL CONDUIT IS SPECIFIED IT SHALL HAVE THREADED FITTINGS. SET SCREW TYPE FITTINGS WILL NOT BE ACCEPTABLE. CONDUITS FOR UNDERGROUND APPLICATIONS SHALL BE AS DETAILED HEREIN. CONDUITS FOR GROUNDING ELECTRODE CONDUCTORS OR INDIVIDUAL GROUNDING CONDUCTORS SHALL BE SCHEDULE 40 OR SCHEDULE 80 PVC.
16. PROVIDE LIQUID TIGHT FLEXIBLE METAL CONDUIT AT CONNECTIONS TO EQUIPMENT SUBJECT TO VIBRATION OR WHERE FLEXIBILITY IS REQUIRED. LIQUID TIGHT FLEXIBLE METAL CONDUIT AND ASSOCIATED FITTINGS SHALL BE U.L. LISTED TO MEET THE REQUIREMENTS OF NEC 350.6, SUITABLE FOR GROUNDING, SUNLIGHT RESISTANT, AND RESISTANT TO OIL, GASOLINE, AND GREASE. LIQUID TIGHT FLEXIBLE METAL CONDUIT THAT IS USED FOR FLEXIBILITY (INCLUDING CONNECTIONS TO MOTORS, TRANSFORMERS, & CONSTANT CURRENT REGULATORS) SHALL REQUIRE AN EXTERNAL BONDING JUMPER OR INTERNAL EQUIPMENT GROUNDING CONDUCTOR PER NEC 350.60. DO NOT INSTALL LIQUID TIGHT FLEXIBLE METAL CONDUIT THAT IS NOT U.L. LISTED.
17. UNLESS OTHERWISE SHOWN, ALL EXPOSED CONDUITS SHALL BE RUN PARALLEL TO OR AT RIGHT ANGLES WITH THE LINES OF THE STRUCTURE.
18. ALL STEEL CONDUITS, FITTINGS, NUTS, BOLTS, ETC. SHALL BE GALVANIZED.
19. USE CONDUIT BUSHINGS AT EACH CONDUIT TERMINATION. WHERE NO. 4 AWG OR LARGER UNDERGROUND WIRE IS INSTALLED, USE INSULATED BUSHINGS.
20. USE DOUBLE LOCK NUTS AT EACH CONDUIT TERMINATION.
21. WRAP ALL PRIMARY AND SECONDARY POWER TRANSFORMER CONNECTIONS WITH SUFFICIENT LAYERS OF INSULATING TAPE (3M SCOTCH 23 ALL-VOLTAGE SPLICING TAPE, 3M SCOTCH 130C LINERLESS RUBBER SPLICING TAPE, OR APPROVED EQUAL) AND COVER WITH VINYL ELECTRICAL TAPE (3M SCOTCH 88 VINYL ELECTRICAL TAPE OR APPROVED EQUAL) FOR FULL VALUE OF CABLE INSULATION VOLTAGE.
22. UNLESS OTHERWISE NOTED, ALL SINGLE CONDUCTOR CONTROL WIRING SHALL BE NO. 12 AWG. COPPER MINIMUM.
23. THE FOLLOWING SHALL APPLY TO RELAY/CONTACTOR PANELS/ENCLOSURES:
A. FOR INTERIOR LOCATIONS ALL COMPONENTS SHALL BE MOUNTED IN NEMA 12 (DUST TIGHT) ENCLOSURE(S) WITH VERTICALLY HINGED COVERS. FOR EXTERIOR/OUTDOOR LOCATIONS ALL COMPONENTS SHALL BE MOUNTED IN NEMA 4X STAINLESS STEEL ENCLOSURE(S) WITH VERTICALLY HINGED COVERS. ALL CONDUIT ENTRIES INTO NEMA 4, 4X ENCLOSURES SHALL HAVE NEMA 4 HUBS LISTED SUITABLE FOR THE RESPECTIVE ENCLOSURE TO MAINTAIN THE NEMA 4, 4X RATING OF THE ENCLOSURE.
B. THE ENCLOSURE(S) SHALL HAVE AMPLE SPACE FOR THE CIRCUIT COMPONENTS, TERMINAL BLOCKS AND INCOMING AND INTERNAL WIRING.
C. ALL CONTROL CONDUCTOR TERMINATIONS SHALL BE OF THE OPEN-EYE CONNECTOR/SCREW TYPE. SOLDERED CLOSED-EYE TERMINATIONS, OR TERMINATIONS WITHOUT CONNECTORS ARE NOT ACCEPTABLE.
D. WHEN THE ENCLOSURE COVER IS OPENED, ALL CIRCUIT COMPONENTS, WIRING AND TERMINALS SHALL BE EXPOSED AND ACCESSIBLE WITHOUT REMOVAL OF ANY PANELS, COVERS, ETC., EXCEPT THOSE COVERING HIGH VOLTAGE COMPONENTS.
E. ACCESS TO, OR REMOVAL OF A CIRCUIT COMPONENT OR TERMINAL BLOCK WILL NOT REQUIRE THE REMOVAL OF ANY OTHER CIRCUIT COMPONENT OR TERMINAL BLOCK.
F. EACH CIRCUIT COMPONENT SHALL BE CLEARLY IDENTIFIED INDICATING ITS CORRESPONDING NUMBER SHOWN ON THE DRAWINGS AND ITS FUNCTION.
G. A COMPLETE WIRING DIAGRAM SHALL BE MOUNTED ON THE INSIDE OF THE COVER. THE DIAGRAM SHALL REPRESENT EACH CONDUCTOR BY A SEPARATE LINE.
H. THE DIAGRAM SHALL IDENTIFY EACH CIRCUIT COMPONENT AN NUMBERING AND COLOR OF EACH TERMINAL CONDUCTOR AND TERMINAL.
I. ALL WIRING SHALL BE NEATLY TRAINED AND LACED.
J. MINIMUM WIRE SIZE SHALL BE NO. 12 AWG.
24. FURNISH & INSTALL A WEATHERPROOF WARNING LABEL FOR EACH METER SOCKET, SERVICE DISCONNECT, SAFETY SWITCH, CUTOUT, PANELBOARD, & CONTROL PANEL TO WARN PERSONS OF POTENTIAL ELECTRIC ARC FLASH HAZARDS, PER THE REQUIREMENTS OF NEC 110.16 "FLASH PROTECTION".

Table with columns: BY, REVISION, DATE

SOUTHERN ILLINOIS AIRPORT MURREYSBORO / CARBONDALE, ILLINOIS



A.I.P. PROJ.: 3-17-0009-B29 I.L. PROJ.: MDH-3892

Table with columns: Revision, Date, Description, Status



Hanson Professional Services Inc. 1525 South Birch Street Springfield, Illinois 62703-2886 Offices Nationwide

REHABILITATE TAXIWAY "B" ELECTRICAL NOTES SHEET 1

MAY 12, 2009 11:48 AM KINCAO0394 \\A-REPORTS\SIA-CARBONDALE\08A0067\CADD\AIRPORT\1\SHEET\R-543ELE.DWG - Work

AIRFIELD LIGHTING NOTES

1. UNLESS OTHERWISE NOTED, ALL UNDERGROUND AIRFIELD LIGHTING SERIES CIRCUIT CONDUCTORS WHETHER DEB OR IN DUCT/CONDUIT SHALL BE FAA APPROVED 5000 VOLT L-824 TYPE. ALL UNDERGROUND FIELD POWER LOW VOLTAGE (600 VOLT & BELOW) CIRCUIT CONDUCTORS WHETHER DEB OR IN DUCT/CONDUIT SHALL BE UL LISTED 600 VOLT, TYPE XLP-USE-2 COPPER CONDUCTORS. CONDUCTOR SIZES SHALL BE AS SPECIFIED, HEREIN.
2. NO COMPONENTS OF PRIMARY CIRCUIT SUCH AS CABLE, CONNECTORS AND TRANSFORMERS SHALL BE BROUGHT ABOVE GROUND AT EDGE LIGHTS, SIGNS, REIL, PAPI, ETC.
3. THERE SHALL BE NO EXPOSED POWER/CONTROL CABLES BETWEEN THE POINT WHERE THEY LEAVE THE UNDERGROUND (DEB OR L-867 BASES) AND WHERE THEY ENTER THE EQUIPMENT (SUCH AS TAXIWAY SIGNS, PAPI, REIL, ETC.) ENCLOSURES. THESE CABLES SHALL BE ENCLOSED IN RIGID CONDUIT OR IN FLEXIBLE, WATERTIGHT CONDUIT WITH BREAKABLE COUPLING(S) AT THE GRADE OR THE HOUSING COVER, AS SHOWN IN APPLICABLE DETAILS.
4. THE JOINTS OF THE L-823 PRIMARY CONNECTORS SHALL BE WRAPPED WITH AT LEAST ONE LAYER OF RUBBER OR SYNTHETIC RUBBER TAPE AND ONE LAYER OF PLASTIC TAPE, ONE-HALF LAPPED, EXTENDING AT LEAST 1-1/2 INCHES ON EACH SIDE OF THE JOINT, AS SHOWN ON SHEET NO. 9.
5. THE CABLE ENTRANCE INTO THE FIELD-ATTACHED L-823 CONNECTORS SHALL BE ENCLOSED BY A HEAT-SHRINKABLE TUBING WITH CONTINUOUS INTERNAL ADHESIVE, AS SHOWN ON SHEET NO. 9.
6. L-823 TYPE II, TWO-CONDUCTOR SECONDARY CONNECTORS SHALL BE CLASS 'A' (FACTORY MOLDED).
7. THERE SHALL BE NO SPLICES IN THE SECONDARY CABLE(S) WITHIN THE STEMS OF A RUNWAY/TAXIWAY EDGE/THRESHOLD LIGHTING FIXTURE AND THE WIREWAYS LEADING TO TAXIWAY SIGNS AND PAPI/REIL EQUIPMENT.
8. ELECTRICAL INSULATING GREASE SHALL BE APPLIED WITHIN THE L-823, SECONDARY, TWO CONDUCTOR CONNECTORS TO PREVENT WATER ENTRANCE. THESE CONNECTORS SHALL NOT BE TAPED.
9. DEB ISOLATION TRANSFORMERS SHALL BE BURIED AT A DEPTH OF TEN (10") INCHES ON A LINE CROSSING THE LIGHT AND PERPENDICULAR TO THE RUNWAY/TAXIWAY CENTERLINE AT A LOCATION TWELVE (12") INCHES FROM THE LIGHT OPPOSITE FROM THE RUNWAY/TAXIWAY.
10. A SLACK OF THREE (3') FEET, MINIMUM, SHALL BE PROVIDED IN THE PRIMARY CABLE AT EACH TRANSFORMER/CONNECTOR TERMINATION. AT STAKE-MOUNTED LIGHTS, THE SLACK SHALL BE LOOSELY COILED IMMEDIATELY BELOW THE ISOLATION TRANSFORMER.
11. DIRECTION OF PRIMARY CABLES SHALL BE IDENTIFIED BY COLOR CODING AS FOLLOWS: WHEN FACING LIGHT WITH BACK TO PAVEMENT, CABLE TO THE LEFT IS CODED RED AND CABLE TO RIGHT IS CODED BLUE. THIS APPLIES TO STAKE MOUNTED LIGHTS AND BASE MOUNTED LIGHTS WHERE THE BASE HAS ONLY ONE ENTRANCE.
12. L-867 BASES SHALL BE SIZE B, 24" DEEP, CLASS I, UNLESS OTHERWISE NOTED.
13. BASE MOUNTED BREAKABLE COUPLINGS SHALL NOT HAVE WEEP HOLES TO THE OUTSIDE. PLUGGED UP HOLES SHALL NOT BE ACCEPTABLE. IT SHALL BE A 1/4" DIAMETER, MINIMUM, OR EQUIVALENT OPENING FOR DRAINAGE FROM THE SPACE AROUND THE SECONDARY CONNECTOR INTO THE L-867 BASE.
14. THE ELEVATION OF THE BREAKABLE COUPLING GROOVE SHALL NOT EXCEED 1-1/2" ABOVE THE EDGE OF THE COVER IN CASE OF BASE MOUNTED COUPLINGS, OR THE TOP OF THE STAKE IN CASE OF STAKE MOUNTED COUPLINGS.
15. WHERE THE BREAKABLE COUPLING IS NOT AN INTEGRAL PART OF THE LIGHT FIXTURE STEM OR MOUNTING LEG, A BEAD OF SILICON SEAL SHALL BE APPLIED COMPLETELY AROUND LIGHT STEM OR WIREWAY AT BREAKABLE COUPLING TO PROVIDE A WATERTIGHT SEAL.
16. TOPS OF THE STAKES SUPPORTING LIGHT FIXTURES SHALL BE FLUSH WITH THE SURROUNDING GRADE.
17. PLASTIC LIGHTING FIXTURE COMPONENTS, SUCH AS LAMP HEADS, STEMS, BREAKABLE COUPLINGS, BASE COVERS, BRACKETS, STAKES, SHALL NOT BE ACCEPTABLE.
18. THE TOLERANCE FOR THE HEIGHT OF RUNWAY/TAXIWAY EDGE LIGHTS SHALL BE: ONE (1) INCH. IN CASE OF STAKE MOUNTED LIGHTS, THE SPECIFIED LIGHTING FIXTURE HEIGHT SHALL BE MEASURED BETWEEN THE TOP OF THE STAKE AND THE TOP OF THE LENS. IN CASE OF BASE MOUNTED LIGHTS, THE SPECIFIED LIGHTING FIXTURE HEIGHT SHALL BE MEASURED BETWEEN THE TOP OF THE BASE FLANGE AND THE TOP OF THE LENS, THUS INCLUDING THE BASE COVER, THE FRANGIBLE COUPLING, THE STEM, THE LAMP HOUSING AND THE LENS.
19. THE TOLERANCE FOR THE LATERAL SPACING (LIGHT LANE TO RUNWAY/TAXIWAY CENTERLINE) OF RUNWAY/TAXIWAY EDGE LIGHTS SHALL BE ONE (1) INCH. THIS ALSO APPLIES AT INTERSECTIONS TO LATERAL SPACING BETWEEN LIGHTS OF A RUNWAY/TAXIWAY AND THE INTERSECTING RUNWAY/TAXIWAY.

20. ENTRANCES INTO L-867 BASES SHALL HAVE CONDUIT COUPLINGS OR REDUCERS TO INTERFACE UNIT DUCT/CONDUIT TO L-867 BASE HUBS, OR SHALL BE SEALED WITH HEAT SHRINK AS SHOWN IN DETAIL "B" ON SHEET NO. 8.
21. GALVANIZED/PAINTED EQUIPMENT/COMPONENT SURFACES SHALL NOT BE DAMAGED BY DRILLING, FILING, ETC. DRAIN HOLES IN METAL TRANSFORMER HOUSINGS SHALL BE MADE BEFORE GALVANIZING.
22. EDGE LIGHT NUMBERING TAGS SHALL BE FACING THE PAVEMENT.
23. CABLE/SPLICE/DUCT MARKERS SHALL BE PRECAST CONCRETE OF THE SIZE SHOWN. LETTERS/NUMBERS/ARROWS FOR THE LEGEND TO BE IMPRESSED INTO THE TOPS OF THE MARKERS SHALL BE PRE-ASSEMBLED AND SECURED IN THE MOLD BEFORE THE CONCRETE IS POURED. LEGEND INSCRIBED BY HAND IN WET CONCRETE SHALL NOT BE ACCEPTABLE.
24. ALL UNDERGROUND CABLE RUNS SHALL BE IDENTIFIED BY CABLE MARKERS AT 200 FEET MAXIMUM SPACING, WITH AN ADDITIONAL MARKER AT EACH CHANGE OF DIRECTION OF THE CABLE RUN. CABLE MARKERS SHALL BE INSTALLED IMMEDIATELY ABOVE THE CABLES.
25. THERE SHALL BE NO SPLICES BETWEEN THE ISOLATION TRANSFORMERS. L-823 CONNECTORS ARE ALLOWED AT TRANSFORMER CONNECTIONS ONLY, UNLESS OTHERWISE SHOWN.
26. APPLY AN OXIDE INHIBITING, ANTI-SEIZING COMPOUND TO ALL SCREWS, NUTS AND BREAKAGE COUPLING THREADS.
27. LOCATIONS OF ENDS OF ALL UNDERGROUND DUCTS SHALL BE IDENTIFIED BY DUCT MARKERS.
28. WHERE A PARALLEL, CONSTANT VOLTAGE PAPI SYSTEM IS PROVIDED, THE "T" SPLICES SHALL BE OF THE CAST TYPE.
29. CONCRETE USED FOR SLABS, FOOTINGS, BACKFILL AROUND TRANSFORMER HOUSINGS, MARKINGS, ETC. SHALL BE 3000 PSI, AIR-ENTRAINED.
30. ALL POWER AND CONTROL CABLES IN MAN/HAND HOLES SHALL BE TAGGED. USE EMBOSSED COPPER STRIPS TO BE ATTACHED AT BOTH ENDS TO THE CABLE BY THE USE OF PLASTIC STRAPS. MINIMUM OF TWO TAGS SHALL BE PROVIDED ON EACH CABLE IN A MAN/HAND HOLE-ONE AT THE CABLE ENTRANCE AND ONE AT THE CABLE EXIT.
31. THE LOCATION, SIZE AND TYPE OF MATERIAL OF EXISTING UNDERGROUND UTILITIES INDICATED ON THE PLANS IS NOT REPRESENTED AS BEING ACCURATE, SUFFICIENT OR COMPLETE. IT SHALL BE THE CONTRACTOR'S RESPONSIBILITY TO DETERMINE THE ACTUAL LOCATION OF ALL SUCH FACILITIES, INCLUDING SERVICE CONNECTIONS TO UNDERGROUND UTILITIES. PRIOR TO CONSTRUCTION, THE CONTRACTOR SHALL NOTIFY THE UTILITY COMPANIES OF HIS OPERATIONAL PLANS AND SHALL OBTAIN FROM THE RESPECTIVE UTILITY COMPANIES DETAILED INFORMATION AND ASSISTANCE RELATIVE TO THE LOCATION OF THEIR FACILITIES AND THE WORKING SCHEDULE OF THE COMPANIES FOR REMOVAL OR ADJUSTMENT WHERE REQUIRED. IN THE EVENT AN UNEXPECTED UTILITY INTERFERENCE IS ENCOUNTERED DURING CONSTRUCTION, THE CONTRACTOR SHALL IMMEDIATELY NOTIFY THE UTILITY COMPANY OF JURISDICTION. THE ENGINEER SHALL ALSO BE IMMEDIATELY NOTIFIED. ANY SUCH MAINS AND SERVICES SHALL BE RESTORED TO SERVICE AT ONCE AND PAID FOR BY THE CONTRACTOR AT NO ADDITIONAL COST TO THE CONTRACT. CALL J.U.L.I.E. FOR UTILITY INFORMATION AT 1-800-892-0123. ALSO CONTACT AIRPORT MANAGER AND/OR RESPECTIVE AIRPORT PERSONNEL FOR ASSISTANCE IN LOCATING UNDERGROUND AIRPORT CABLES AND/OR UTILITIES. CONTACT FAA FOR ASSISTANCE IN LOCATING THEIR CABLES.
32. WHEN PREPARING CABLE FOR SPLICES, THE CONTRACTOR SHALL USE A CABLE STRIPPER/PENCILLER WHENEVER CABLE CONNECTIONS ARE MADE.

GROUNDING NOTES FOR AIRFIELD LIGHTING

1. GROUNDING FOR RUNWAY LIGHTS, TAXIWAY LIGHTS, AND LIGHTED TAXI GUIDANCE SIGNS SHALL BE AS DETAILED ON THE PLANS AND AS SPECIFIED HEREIN. PER FAA AC 150/5340-30D DESIGN AND INSTALLATION DETAILS FOR AIRPORT VISUAL AIDS, CHAPTER 12, PART 12.6; A SAFETY GROUND MUST BE INSTALLED AT EACH LIGHT FIXTURE. THE PURPOSE OF THE SAFETY GROUND IS TO PROTECT PERSONNEL FROM POSSIBLE CONTACT WITH AN ENERGIZED LIGHT BASE OR MOUNTING STAKE AS THE RESULT OF A SHORTED CABLE OR ISOLATION TRANSFORMER. A SAFETY GROUND SHALL BE INSTALLED AT EACH TRANSFORMER BASE/LIGHT CAN ASSOCIATED WITH RUNWAY LIGHTS, TAXIWAY LIGHTS, AND LIGHTED TAXI GUIDANCE SIGNS. A SAFETY GROUND SHALL ALSO BE INSTALLED AT EACH STAKE MOUNTED LIGHT FIXTURE. THE SAFETY GROUND SHALL BE A #6 AWG BARE COPPER CONDUCTOR CONNECTED TO THE GROUND LUG ON THE RESPECTIVE L-867 TRANSFORMER BASE/LIGHT CAN OR MOUNTING STAKE AND A 5/8-INCH DIAMETER BY 8-FOOT LONG (MINIMUM) UL LISTED COPPER CLAD GROUND ROD. CONNECTIONS TO GROUND LUGS ON THE L-867 TRANSFORMER BASE/LIGHT CAN OR MOUNTING STAKE SHALL BE WITH A UL LISTED GROUNDING CONNECTOR. CONNECTIONS TO GROUND RODS SHALL BE MADE WITH EXOTHERMIC WELD TYPE CONNECTORS, CADWELD BY ERICO PRODUCTS, INC., SOLOM, OHIO, (PHONE: 800-248-9353), THERMOWELD BY CONTINENTAL INDUSTRIES, INC., TULSA, OKLAHOMA (PHONE: 918-663-1440) OR ULTRAWELD BY HARGER, GRAYSLAKE, ILLINOIS (PHONE: 800-842-7437). EXOTHERMIC WELD CONNECTIONS SHALL BE INSTALLED IN CONFORMANCE WITH THE RESPECTIVE MANUFACTURER'S DIRECTIONS USING MOLDS AS REQUIRED FOR EACH RESPECTIVE APPLICATION. BOLTED CONNECTIONS WILL NOT BE PERMITTED AT GROUND RODS. TOP OF GROUND RODS SHALL BE BURIED 12 INCHES MINIMUM BELOW GRADE, UNLESS SPECIFIED OTHERWISE HEREIN, FOR RESPECTIVE APPLICATIONS.
2. CLEAN ALL METAL SURFACES BEFORE MAKING GROUND CONNECTIONS. METALLIC SURFACES TO BE JOINED SHALL BE PREPARED BY THE REMOVAL OF ALL NON-CONDUCTIVE MATERIAL PER 2008 NATIONAL ELECTRICAL CODE ARTICLE 250-12.
3. PER FAA 150/5340-30D THE RESISTANCE TO GROUND OF THE RESPECTIVE MOUNTING STAKE OR LIGHT BASE (WITH GROUND ROD CONNECTED) MUST BE 25 OHMS OR LESS.

| DATE | REVISION | BY |
|------|----------|----|
| | | |
| | | |
| | | |
| | | |
| | | |

SOUTHERN ILLINOIS AIRPORT
MURPHYSBORO / CARBONDALE, ILLINOIS



A.I.P. PROJ.: 3-17-0009-B29
IL PROJ.: MDH-3892

| | |
|----------------------------------|----------|
| Hanson Project No. 0840067D-0800 | 01/26/09 |
| Filename R-544ELE.DWG | KNL |
| Scale NOT TO SCALE | MV |
| Date 01/26/09 | CAH |
| LAYOUT | 04/10/09 |
| DRAWN | 01/26/09 |
| REVIEWED | |



Hanson Professional Services Inc.
1525 South State Street
Springfield, Illinois 62703-2886
Offices Nationwide

REHABILITATE TAXIWAY "B"
ELECTRICAL NOTES
SHEET 2

MAY 12, 2009 11:48 AM KINCA00394
 J:\AIRPORTS\SIA-CARBONDALE\0840067\CADD\AIRPORT\SHEET\B-544ELE.DWG - Work