

REVISIONS		
NUMBER	BY	DATE

0 1 2
THIS BAR IS EQUAL TO 2'
AT FULL SCALE (34X22).
PLOT 1

**MIDAMERICA ST. LOUIS AIRPORT
ST. CLAIR COUNTY, ILLINOIS**

RUNWAY AND TAXIWAY JOINT REPAIR

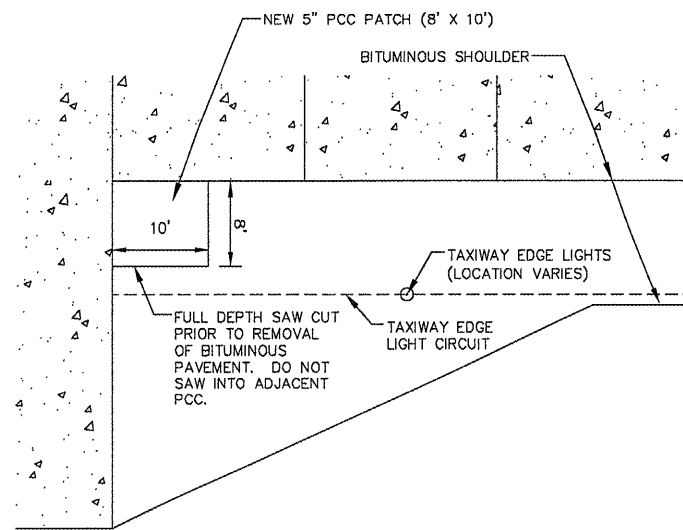

SHOULDER REPAIR — PLAN VIEW
NOT TO SCALE

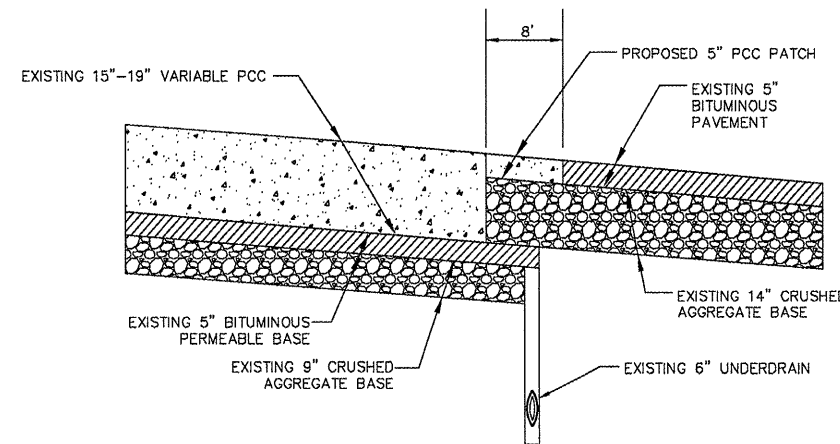

TYPICAL SECTION — SHOULDER REPAIR
NOT TO SCALE

ONE MEMORIAL DRIVE, SUITE 500
ST. LOUIS, MO 63102
(314) 436-5500



**IL PROJECT: BLV-3886
AIP PROJ: 3-17-0146-XX**

FILE: 09_SHOULDER_REPAIR.dwg

DESIGN BY: LEW

DRAWN BY: ASA

CHECKED BY: BWG

APPROVED BY: BWG

DATE: APRIL 17, 2009

JOB No: 09098-01

**SHOULDER
REPAIR DETAILS**

SHEET 9 OF 9 SHEETS