

NOTES

- CROSS SECTIONS ARE BASED ON ALTERNATE BID A. ADD 2 INCH CUT FOR ALTERNATE BID B. SURFACE GRADES SHALL REMAIN THE SAME FOR EITHER ALTERNATE.
- ELEVATIONS PROVIDED AT LOCATIONS THAT MATCH EXISTING PAVEMENTS OR BUILDING FLOORS ARE FOR REFERENCE ONLY. THE CONTRACTOR SHALL CONSTRUCT THE PROPOSED JOINTS FLUSH WITH EXISTING OR AS DETAILED. CONTRACTOR IS RESPONSIBLE FOR VERIFYING EXISTING ELEVATIONS AT MATCH POINTS.

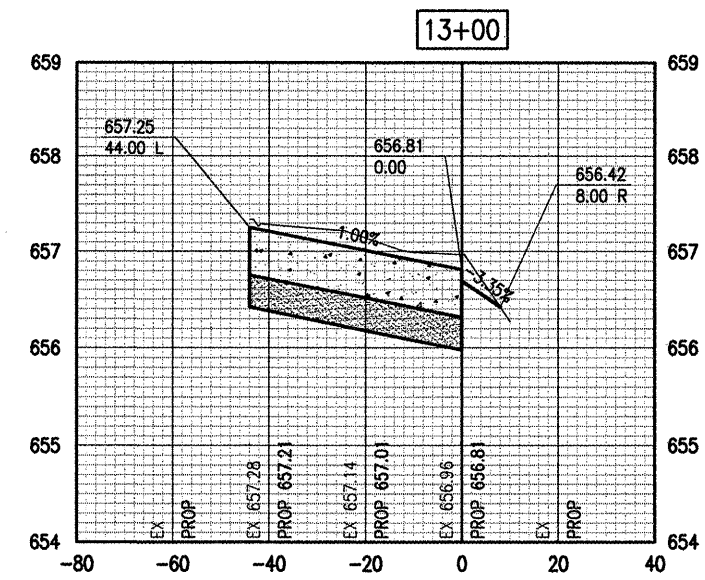
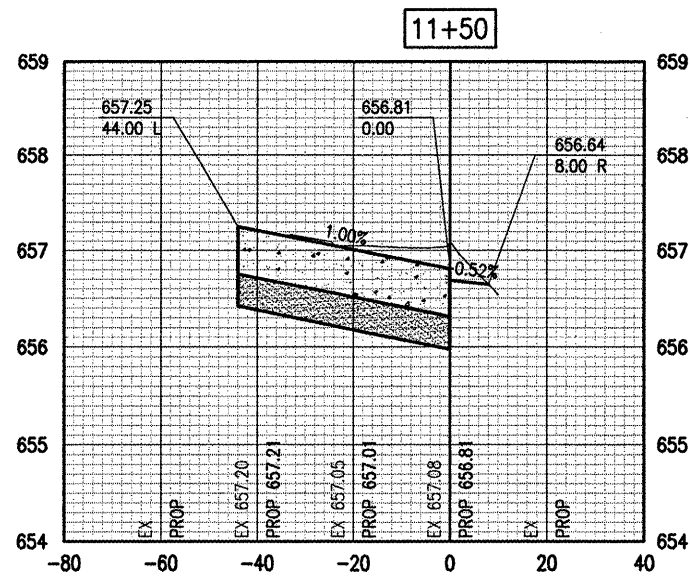
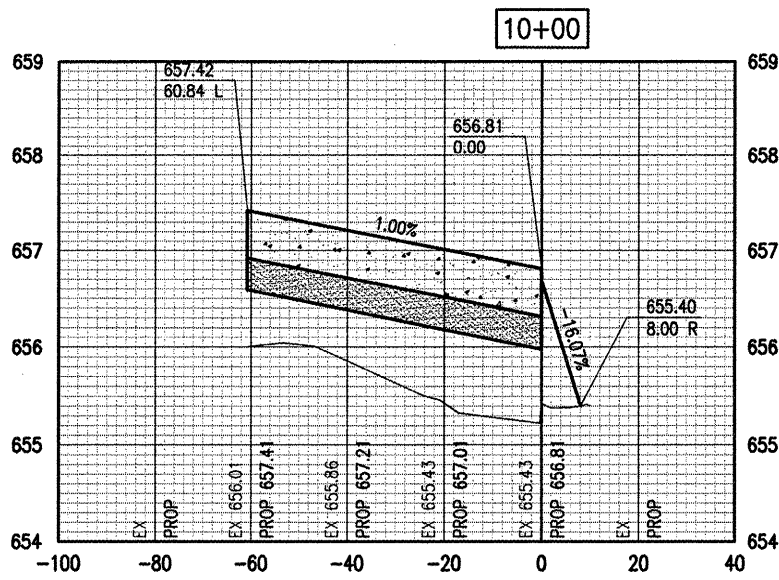
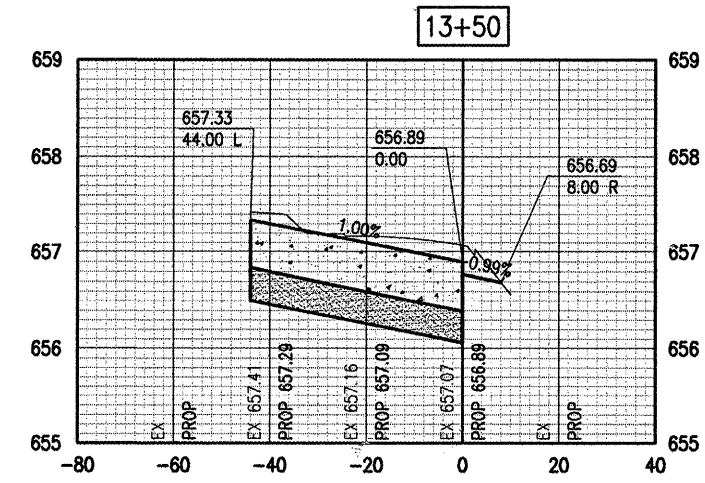
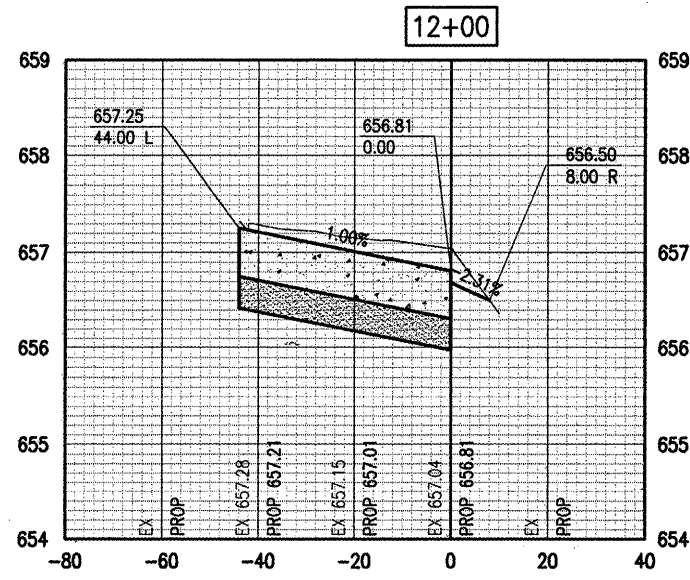
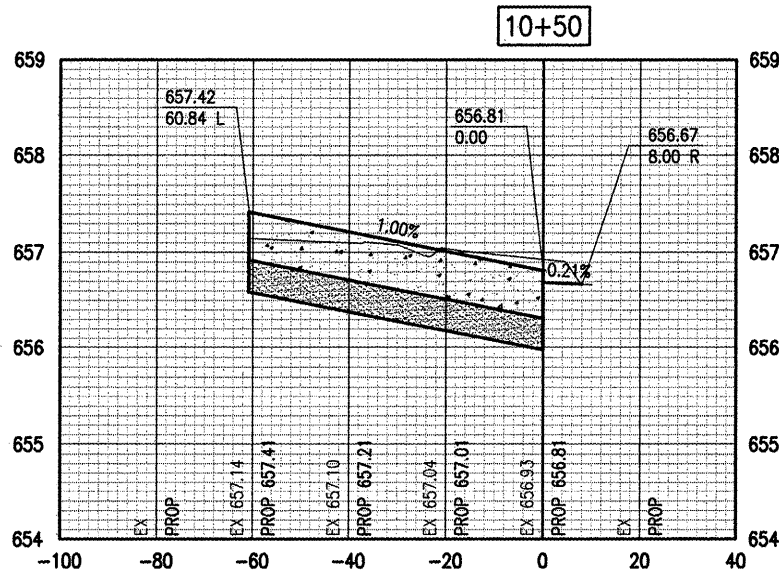
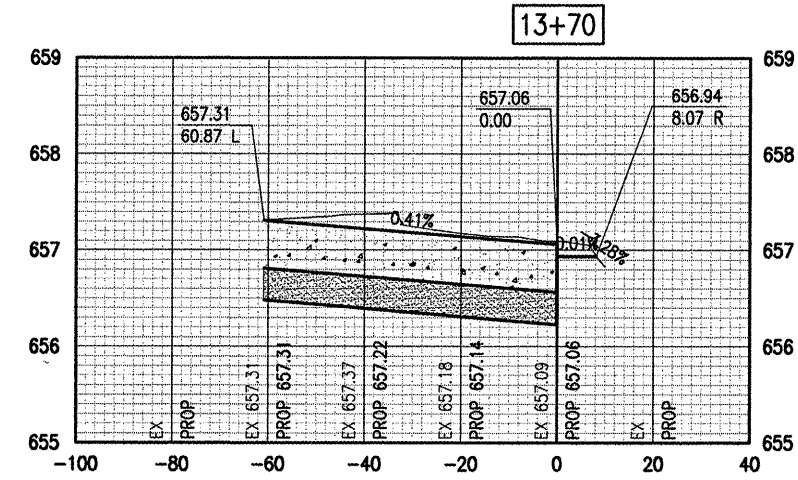
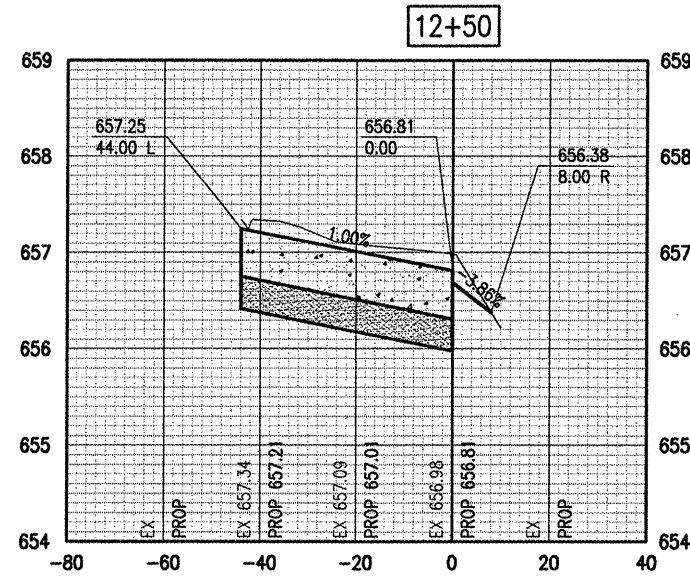
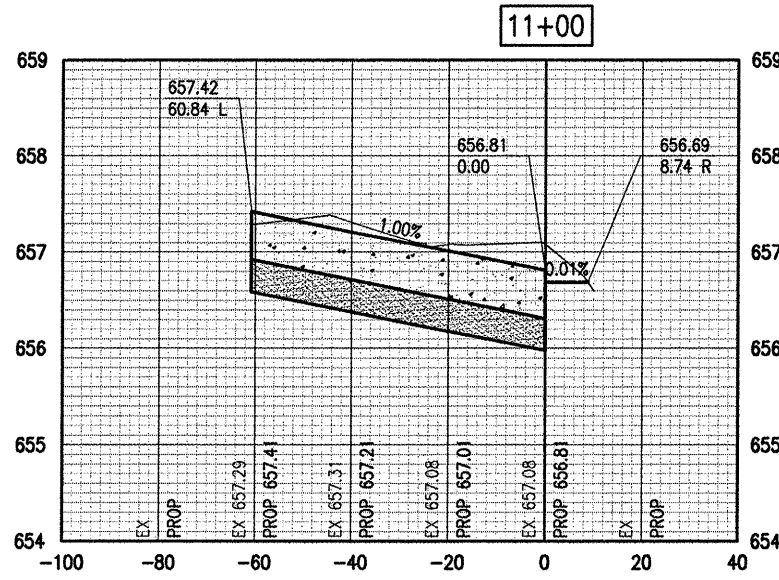

DATE	REVISION	BY

EDGAR COUNTY AIRPORT
 PARIS, ILLINOIS
 A.I.P. PROJ.: 3-17-0077-B11

LAYOUT	DAK	03/06/09
DRAWN	DAK	03/06/09
REVIEWED	JJW	03/18/09

HANSON
 Copyright Hanson Professional Services Inc. 2009
 Hanson Professional Services Inc.
 1525 South Sixth Street
 Springfield, Illinois 62703-2888
 www.hanson-inc.com
 Offices Nationwide

REMOVE AND RECONSTRUCT
 T-HANGAR TAXIWAYS
 PROPOSED CROSS SECTIONS -
 EAST ALIGNMENT
 STA. 10+00 TO STA. 13+99