

STATE OF ILLINOIS
DEPARTMENT OF TRANSPORTATION

*Omit weld at seal opening.
**When joint is fixed, dimension is set at 1 1/2".

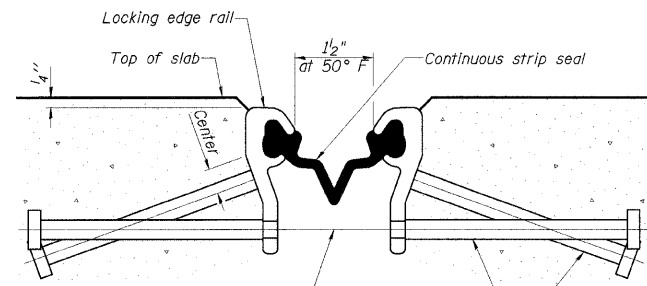

7/16" ϕ holes at 4'-0" cts. for 3/8" ϕ bolts. All bolts shall be burned, sawed, or chipped off flush with the plates after forms are removed, typ.

Place 1/2" ϕ x 6" granular or solid flux filled headed studs conforming to Article 1006.32 of the Std. Specs., automatically end welded at 1'-0" alt. cts.

**SECTION THRU STRIP SEAL JOINT
FOR OVERLAY OVER DECK BEAMS**

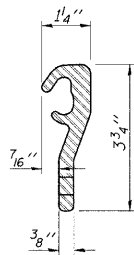

LOCKING EDGE RAIL

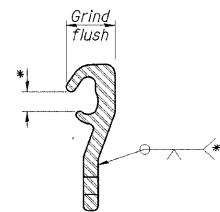

LOCKING EDGE RAIL SPLICE

Notes:
The strip seal shall be made continuous and shall have a minimum thickness of 1/4". The configuration of the strip seal shall match the configuration of the Locking Edge Rails.
The height and thickness of the Locking Edge Rails shown are minimum dimensions. The actual configuration of the Locking Edge Rails and matching strip seal may vary from manufacturer to manufacturer. Flanged edge rails will not be allowed.
The inside of the Locking Edge Rail groove shall be free of weld residue.
Locking Edge Rails may be spliced at slope discontinuities and stage construction joints.
The manufacturer's recommended installation methods shall be followed.

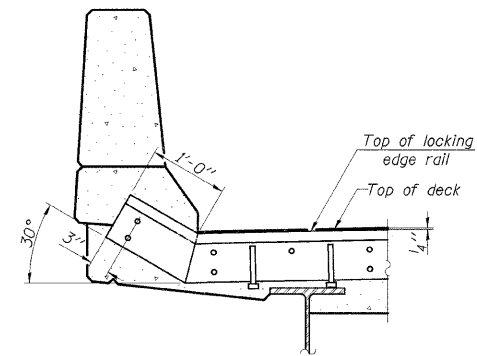

**TYPICAL END TREATMENT
AT PARAPET**

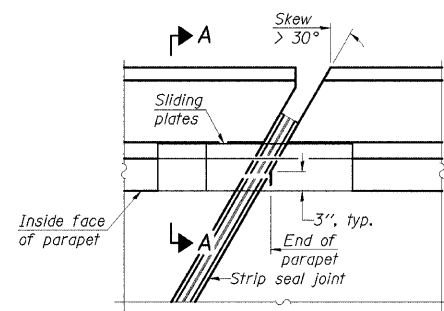

PLAN

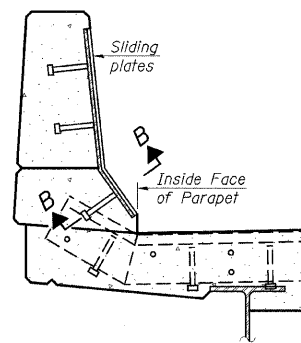

SECTION A-A

**POINT BLOCK DETAILS
(for skews > 30°)**

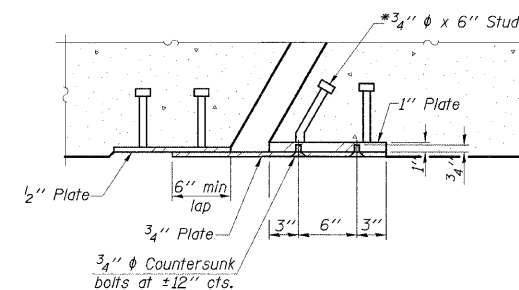

SECTION B-B

BILL OF MATERIAL (BOTH JOINTS)

Item	Unit	Total
Preformed Joint Strip Seal	Foot	115

**PREFORMED JOINT STRIP SEAL
STRUCTURE NO. 044-0031**

FILE NAME =	USER NAME = cornellm	DESIGNED -	REVISED -
c:\pw\work\FW1001\CORNELLM\dms47925\044-0031-bsmart.dgn		DRAWN -	REVISED -
	PLOT SCALE = 1.0000 / IN.	CHECKED -	REVISED -
	PLOT DATE = 2/27/2009	DATE -	REVISED -

**STATE OF ILLINOIS
DEPARTMENT OF TRANSPORTATION**

**PREFORMED JOINT STRIP SEAL DETAILS
SN 044-0031**

SCALE: SHEET NO. OF SHEETS STA. TO STA.

F.A.I. RTE.	SECTION	COUNTY	TOTAL SHEET NO.
24/57	D9 BSMART FY09-1	JOHNSON/PULASKI	20 / 17
FED. ROAD DIST. NO. ILLINOIS FED. AID PROJECT			CONTRACT NO. 78095