

TANGENT SECTION  
STA. 226+93 TO STA. 234+55

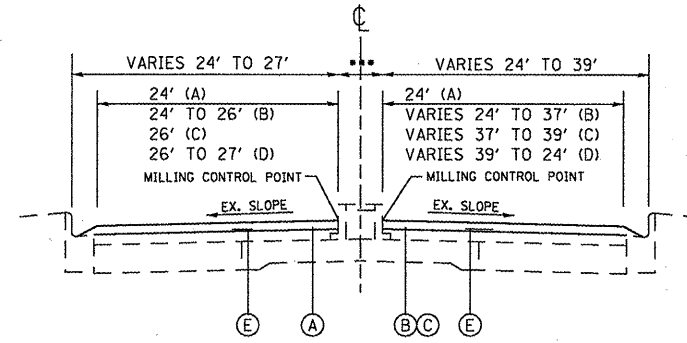

TANGENT SECTION  
STA. 257+87 TO STA. 259+68 (A)  
STA. 259+68 TO STA. 260+80 (B)  
STA. 260+80 TO STA. 264+02 (C)  
STA. 264+02 TO STA. 268+22 (D)

\*\*\* 7' (A)  
VARIES 7' TO 3' (B)  
3' (C)  
VARIES 3' TO 18' (D)

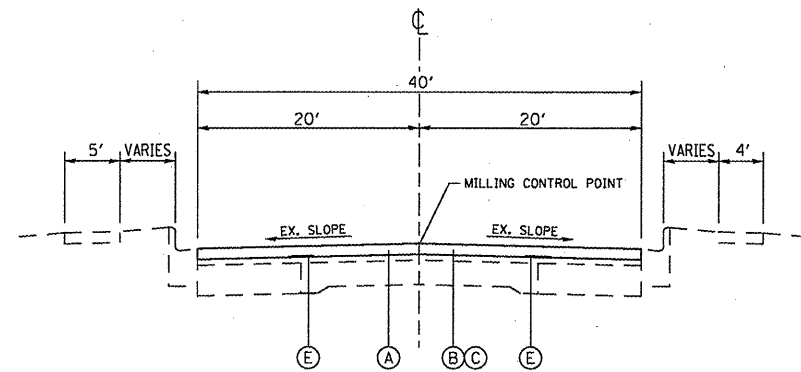

TANGENT SECTION  
STA. 234+55 TO STA. 250+05

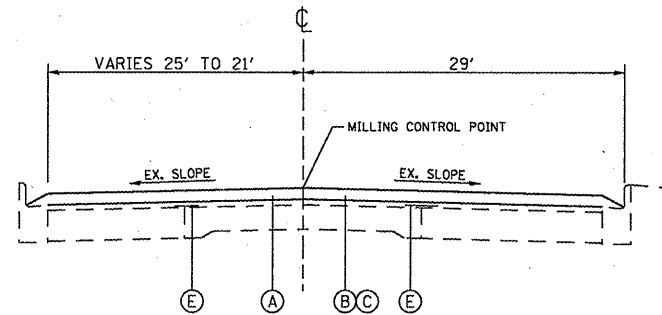

TANGENT SECTION  
STA. 268+22 TO STA. 270+03

- LEGEND
- (A) PROPOSED HMA SURFACE REMOVAL, 2 1/4"
  - (B) PROPOSED POLYMERIZED HMA SURFACE COURSE, MIX "D", N90, 1 1/2"
  - (C) PROPOSED LEVELING BINDER (MACHINE METHOD), N90, 3/4"
  - (D) PROPOSED AGGREGATE SHOULDER, TYPE B, 2"
  - (E) PROPOSED STRIP REFLECTIVE CRACK CONTROL TREATMENT
  - (F) PROPOSED HMA SHOULDERS, 8"

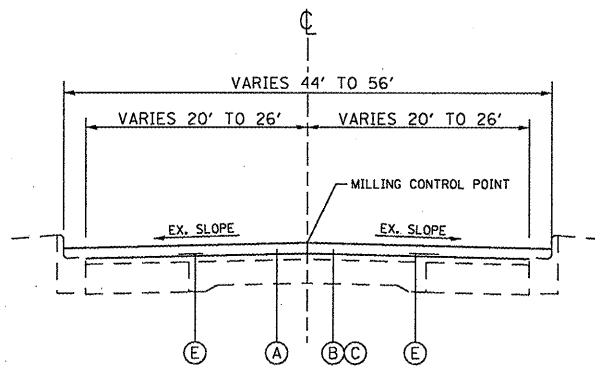

TANGENT SECTION  
STA. 250+05 TO STA. 254+25 LT  
STA. 250+05 TO STA. 254+64 RT

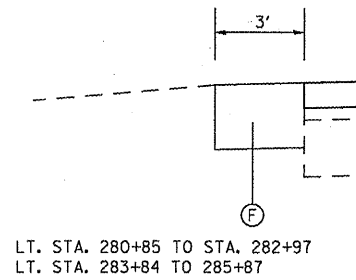

LT. STA. 280+85 TO STA. 282+97  
LT. STA. 283+84 TO 285+87

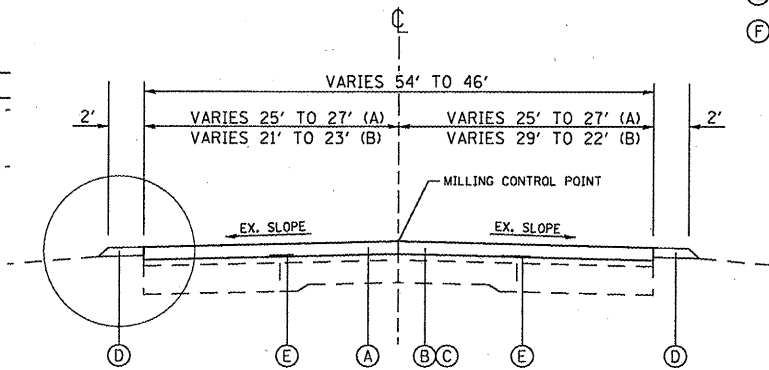

TANGENT SECTION  
STA. 254+25 TO STA. 257+87 LT (A)  
STA. 254+64 TO STA. 257+87 RT (A)  
STA. 270+03 TO STA. 302+97 LT (B)  
STA. 270+03 TO STA. 303+66 RT (B)

EXPOSED CURB & GUTTER  
LT STA. 250+05 TO 251+00  
RT STA. 250+05 TO 252+30

|             |                      |            |           |
|-------------|----------------------|------------|-----------|
| FILE NAME = | USER NAME = #USER#   | DESIGNED - | REVISED - |
| #FILE#      |                      | DRAWN -    | REVISED - |
|             | PLOT SCALE = #SCALE# | CHECKED -  | REVISED - |
|             | PLOT DATE = #DATE#   | DATE -     | REVISED - |

STATE OF ILLINOIS  
DEPARTMENT OF TRANSPORTATION

PROPOSED TYPICAL SECTIONS

SCALE: \_\_\_\_\_ SHEET NO. \_\_\_\_\_ OF \_\_\_\_\_ SHEETS STA. \_\_\_\_\_ TO STA. \_\_\_\_\_

|   |             |         |              |           |
|---|-------------|---------|--------------|-----------|
| F.A.P. RTE.   | SECTION     | COUNTY  | TOTAL SHEETS | SHEET NO. |
| 594   | (61-63)RS-3 | MADISON | 40           | 10        |
| CONTRACT NO. 76B71                                  |             |         |              |           |
| FED. ROAD DIST. NO. _____ ILLINOIS FED. AID PROJECT |             |         |              |           |