

CURB ELEVATION

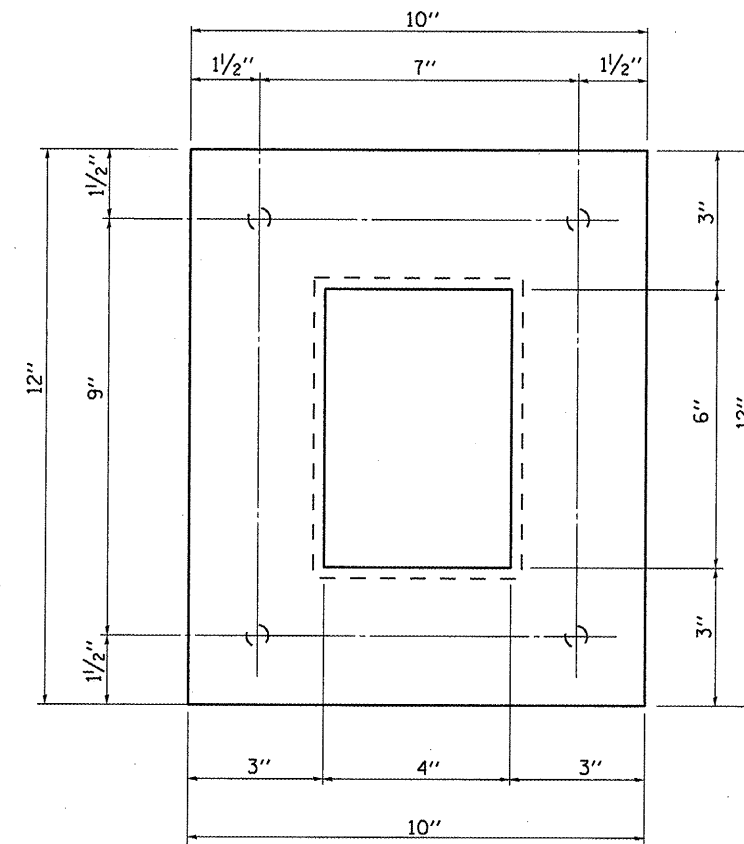

**1/4" x 10" x 1'-0"
ALUMINUM PLATE**

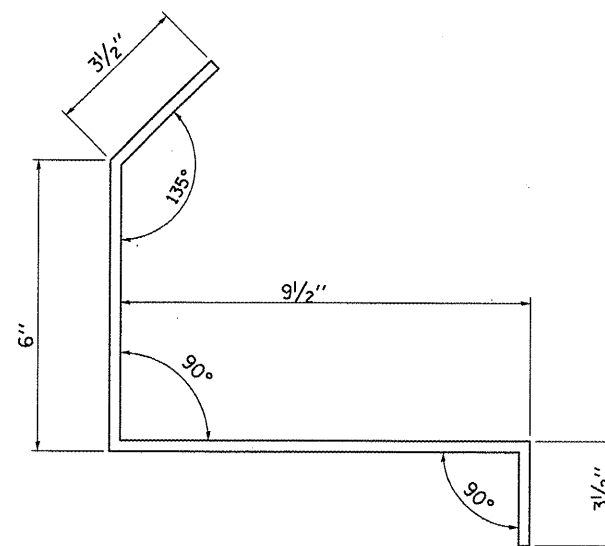

**1/4" x 2" x 1'-10 1/2" BRACKET
(2 REQUIRED PER BEAM)**

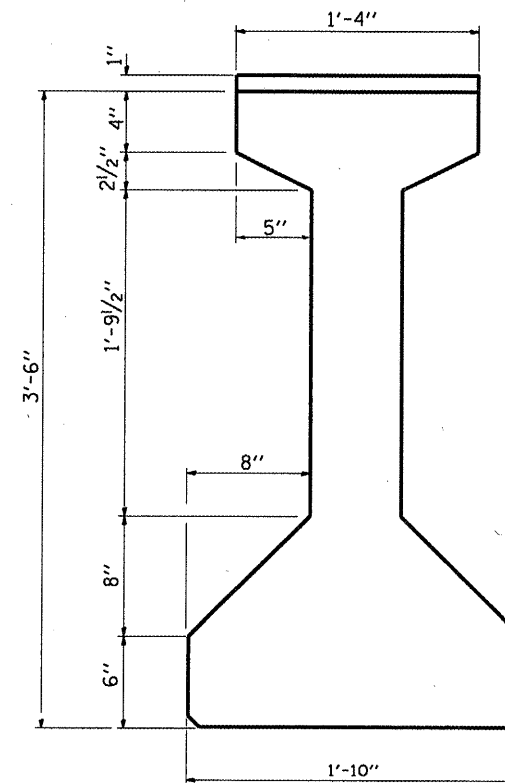

BEAM END SECTION

FILE NAME =	USER NAME = woodshankr-l	DESIGNED - RON WOODSHANK	REVISED -
ct:\pw\work\FWIDOT\WOODSHANKRL\dms91658	0366935-details.dgn	DRAWN - RON WOODSHANK	REVISED -
PLOT SCALE = 40.0000' / IN.	CHECKED -	REVISED -	REVISED -
PLOT DATE = Apr 07, 2009 - 07:53:35 AM	DATE -	REVISED -	REVISED -

STATE OF ILLINOIS
DEPARTMENT OF TRANSPORTATION

Floor
DECK DRAIN EXTENSION DETAILS

SCALE: SHEET NO. 17 OF 18 SHEETS STA. TO STA.

F.A.I. RTE.	SECTION	COUNTY	TOTAL SHEETS	SHEET NO.
80	(50-41)	LASALLE	25	24
CONTRACT NO. 66935			ILLINOIS	