

F.A.U. ROUTE	MUNICIPAL SECTION	COUNTY	TOTAL SHEETS	SHEET NO.
043	08-00108-00-RS	McHENRY	6	1
COVER SHEET				
F.H.W.A. REG.5 ILLINOIS PROJECT M-9003(181)				

STATE OF ILLINOIS

DEPARTMENT OF TRANSPORTATION

DIVISION OF HIGHWAYS

PLANS FOR PROPOSED FEDERAL AID HIGHWAY

F.A.U. 043
CALHOUN STREET RESURFACING
SECTION 08-00108-00-RS
PROJECT NO. M-9003 (181)
CITY OF WOODSTOCK
McHENRY COUNTY
C-91-229-09
RANGE 7 EAST

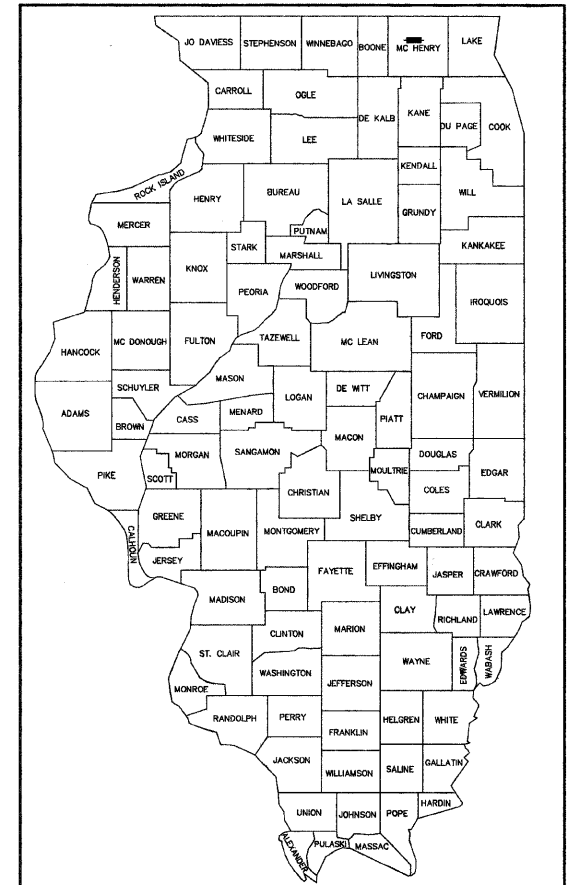

LOCATION OF SECTION INDICATED THIS: —

INDEX TO SHEETS	
SHEET NO.	DESCRIPTION
1	COVER SHEET
2	GENERAL NOTES, TYPICAL SECTION AND SUMMARY OF QUANTITIES
3	PLAN SHEET
4-6	DISTRICT ONE STANDARD DETAILS

STATE STANDARDS

- 000001-05 STANDARD SYMBOLS, ABBREVIATIONS AND PATTERNS
- 602011-01 CATCH BASIN, TYPE C
- 606001-04 CONCRETE CURB TYPE B AND COMBINATION CONCRETE CURB AND GUTTER
- 701301-03 LANE CLOSURE, 2L, 2W, SHORT TIME OPERATIONS
- 701311-03 LANE CLOSURE, 2L, 2W, MOVING OPERATIONS, DAY ONLY
- 701501-05 URBAN LANE CLOSURE, 2L, 2W, UNDIVIDED
- 701901-01 TRAFFIC CONTROL DEVICES
- 780001-02 TYPICAL PAVEMENT MARKINGS

CITY STANDARDS - INCLUDED IN PROPOSAL BOOKLET

- FRAMES AND GRATES
- SANITARY SEWER AND STORM SEWER TRENCH SECTION (IN PAVED AREAS)
- CASTING ADJUSTMENTS FOR STRUCTURES IN PAVED AREAS
- CASTING ADJUSTMENTS FOR STRUCTURES WITHIN THE CURB LINE

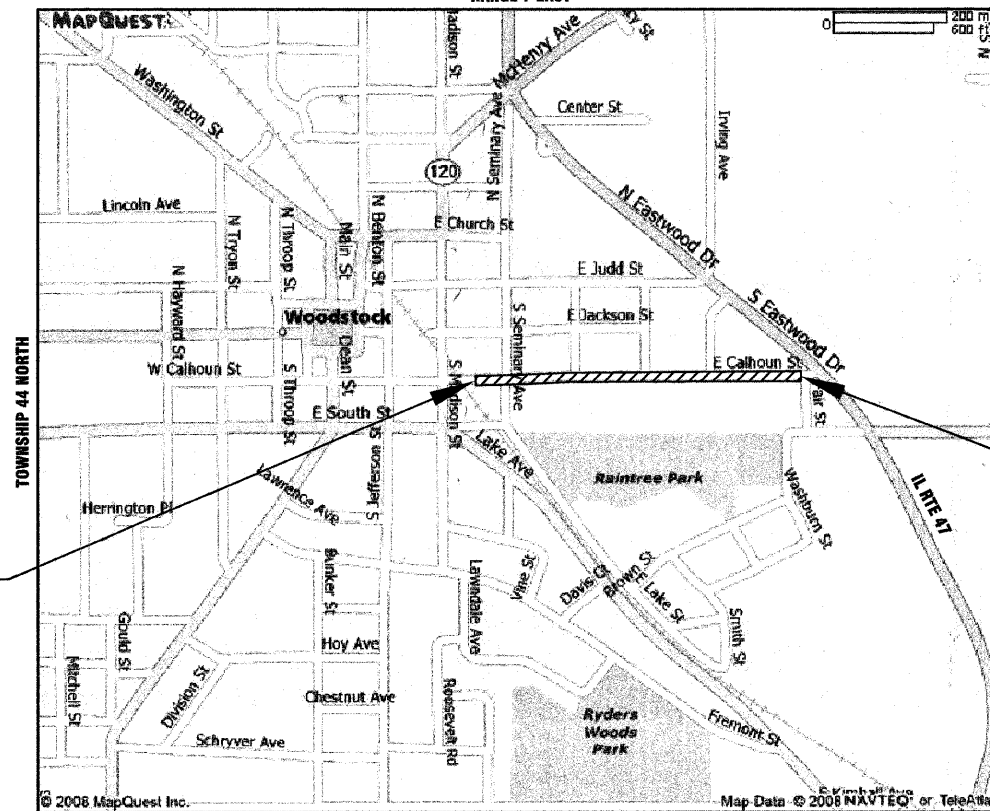

PROJECT BEGINS
STATION 17+25

PROJECT ENDS
STATION 39+12

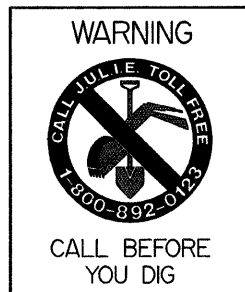

ADT = 6400 (2008)
POSTED SPEED LIMIT = 30 MPH
DESIGN SPEED 35 MPH
CONTRACT NO. 63168

LOCATION MAP
APPROXIMATE SCALE 1" = 550'
GROSS AND NET LENGTH OF PROJECT = 2187 LF (0.414 MILE)

**PRINTED BY THE AUTHORITY
OF THE STATE OF ILLINOIS**

STATE OF ILLINOIS
DEPARTMENT OF TRANSPORTATION
DIVISION OF HIGHWAYS

APPROVED March 20, 2009
J.R. DeBell
CITY OF WOODSTOCK

PASSED MARCH 31, 2009
C. Holt CHRISTOPHER HOLT
DISTRICT 1 ENGINEER OF LOCAL ROADS AND STREETS

RELEASING FOR BID
BASED ON LIMITED
REVIEW APRIL 6, 2009
Diana M. O'Keefe DEPUTY DIRECTOR OF HIGHWAYS REGION 1 ENGINEER

DATE: 2-12-09

BY: Mark A. Stott

LICENSE EXPIRES: NOVEMBER 30, 2009

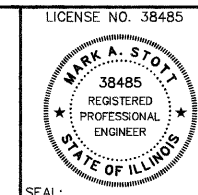

HLR
Hampton Lenzini and Renwick, Inc.
Civil Engineers
Land Surveyors
380 Shepard Drive
Elgin, Illinois 60123-7010
847.697.6700

Account Number
08.0301.330

FEDERAL AID ENGINEER: ALEX HOUSEH 847-705-4410

GENERAL NOTES

ALL WORK SHALL BE IN ACCORDANCE WITH THE "STANDARD SPECIFICATIONS FOR ROAD AND BRIDGE CONSTRUCTION," ADOPTED JANUARY 1, 2007, (HEREINAFTER REFERRED TO AS THE STANDARD SPECIFICATIONS); THE "SUPPLEMENTAL SPECIFICATIONS AND RECURRING SPECIAL PROVISIONS," ADOPTED JANUARY 1, 2009; THE LATEST EDITION OF THE "ILLINOIS MANUAL ON UNIFORM TRAFFIC CONTROL DEVICES FOR STREETS AND HIGHWAYS"; THE DETAILS IN THE PLANS AND THE SPECIAL PROVISIONS INCLUDED IN THE CONTRACT DOCUMENTS.

ANY REFERENCE TO STANDARDS THROUGHOUT THE PLANS OR SPECIAL PROVISIONS SHALL BE INTERPRETED AS THE LATEST STANDARD OF THE ILLINOIS DEPARTMENT OF TRANSPORTATION.

THE CONTRACTOR SHALL COOPERATE WITH THE CITY OF WOODSTOCK IF ANY MUNICIPAL UTILITY IMPROVEMENTS ARE REQUIRED WITHIN THE DURATION OF THE CONTRACT.

THE CONTRACTOR SHALL BE RESPONSIBLE FOR CONTACTING THE OWNERS OF ALL UTILITIES PRIOR TO CONSTRUCTION TO DETERMINE THE LOCATION OF ALL UTILITY EQUIPMENT. THE CONTRACTOR SHALL COOPERATE WITH ALL UTILITY OWNERS AS PROVIDED FOR IN THE STANDARD SPECIFICATIONS IF UTILITY RELOCATION, ADJUSTMENT OR PROTECTION IS NECESSARY.

THE LOCATION ON THE PLANS OF EXISTING DRAINAGE STRUCTURES, STORM SEWERS, WATER MAINS, SANITARY SEWERS, AND ANY OTHER PUBLIC AND PRIVATE UTILITIES IS APPROXIMATE AND THEIR EXACT LOCATIONS ARE TO BE DETERMINED IN THE FIELD BY THE CONTRACTOR AT THE CONTRACTOR'S EXPENSE.

THE CONTRACTOR SHALL BE RESPONSIBLE FOR THE PROTECTION OF ALL UNDERGROUND OR SURFACE UTILITIES EVEN THOUGH THEY MAY NOT BE SHOWN ON THE PLANS. ANY UTILITY THAT IS DAMAGED DURING CONSTRUCTION SHALL BE REPAIRED OR REPLACED TO THE SATISFACTION OF THE OWNER AT THE CONTRACTOR'S EXPENSE.

THE CONTRACTOR SHALL PROTECT AND CAREFULLY PRESERVE ALL SECTION OR SUBSECTION MONUMENTS, PROPERTY CORNERS AND REFERENCE MARKERS UNTIL THE OWNER, HIS AGENT OR A PROFESSIONAL LAND SURVEYOR HAS WITNESSED OR OTHERWISE REFERENCED THEIR LOCATIONS.

ALL ELEVATIONS ARE ON AN ASSUMED LOCAL DATUM.

WHENEVER ANY LOOSE MATERIAL IS DEPOSITED IN THE FLOW LINE OF DRAINAGE STRUCTURES SUCH THAT THE NATURAL FLOW OF WATER IS OBSTRUCTED, THE MATERIAL SHALL BE REMOVED AT THE CLOSE OF EACH WORKING DAY. PRIOR TO ACCEPTANCE OF THE IMPROVEMENT, ANY DRAINAGE STRUCTURES THAT WERE INSTALLED, RECONSTRUCTED OR ADJUSTED AS PART OF THIS CONTRACT SHALL BE FREE OF DIRT AND DEBRIS. THE COST OF THIS WORK WILL NOT BE PAID FOR SEPARATELY BUT SHALL BE INCLUDED IN THE COST OF THE CONTRACT.

WHEN EXISTING DRAINAGE FACILITIES ARE DISTURBED, THE CONTRACTOR SHALL PROVIDE AND MAINTAIN IN AN OPERATING CONDITION TEMPORARY OUTLETS AND CONNECTIONS FOR ALL DRAINS, SEWERS AND CATCH BASINS. THIS WORK WILL NOT BE PAID FOR SEPARATELY, BUT SHALL BE INCLUDED IN THE COST OF THE CONTRACT.

FULL DEPTH SAWING OF REMOVAL ITEMS AS NOTED ON THE PLANS, SPECIFIED IN THE STANDARD SPECIFICATIONS, OR AS REQUIRED BY THE ENGINEER SHALL BE INCLUDED IN THE COST OF THE ITEM BEING REMOVED.

LIDS SHALL READ "WATER", "SANITARY", OR "STORM".

AT ALL BUTT JOINT LOCATIONS, THE EXISTING SURFACE SHALL BE CUT TO A MINIMUM THICKNESS OF 1 1/2 INCHES. ALL BUTT JOINTS REQUIRE SIGNING. RAMPING SHALL BE REQUIRED ON ALL STREETS WIDER THAN 30 FEET, IF NOT SCHEDULED FOR PAVING WITHIN 24 HOURS.

THE THICKNESS OF HMA MIXTURES SHOWN IN THE PLANS ARE NOMINAL. DEVIATIONS MAY OCCUR DUE TO IRREGULARITIES IN THE SURFACES OR BASES ON WHICH THE HMA MIXTURES ARE TO BE PLACED.

THERE SHALL BE NO OVERNIGHT LANE CLOSURES.

THE CONTRACTOR SHALL BE RESPONSIBLE FOR PROTECTING FRESH CONCRETE FROM DAMAGE AND VANDALISM. ANY DAMAGED OR VANDALIZED CONCRETE SHALL BE REMOVED AND REPLACED AT THE CONTRACTOR'S EXPENSE.

IT IS THE CONTRACTOR'S RESPONSIBILITY TO ASCERTAIN EXISTING FIELD CONDITIONS BEFORE BIDDING ON THIS CONTRACT.

ALL TYPE I AND II BARRICADES TO BE LEFT OVERNIGHT SHALL BE WEIGHTED DOWN WITH TWO (2) SANDBAGS EACH.

REMOVED PAVEMENT SHALL BE DISPOSED OF OUTSIDE THE LIMITS OF THE RIGHT-OF-WAY AT THE CONTRACTOR'S EXPENSE AT LOCATIONS PROVIDED OR ARRANGED BY THE CONTRACTOR AND APPROVED BY THE ENGINEER.

LOCATIONS OF COMBINATION CONCRETE CURB AND GUTTER (OTHER THAN SHOWN ON THE PLANS) WILL BE DETERMINED IN THE FIELD BY THE ENGINEER. THE QUANTITIES PROVIDED ARE A REASONABLE ESTIMATE, BUT MAY BE ADJUSTED IN THE FIELD BY THE ENGINEER.

IF EXISTING PAVEMENT OR DRIVEWAY PAVEMENT IS DAMAGED DURING THE REMOVAL OF EXISTING CURB AND GUTTER, THE DAMAGED PAVEMENT SHALL BE REPLACED TO THE SATISFACTION OF THE ENGINEER. NO ADDITIONAL COMPENSATION WILL BE MADE TO THE CONTRACTOR FOR REPAIRS TO DAMAGED PAVEMENT.

A MAXIMUM OF 12" OF ADJUSTING RINGS WILL BE PERMITTED FOR ANY STRUCTURE ADJUSTMENT OR RECONSTRUCTION.

SUMMARY OF QUANTITIES

CODE NO.	ITEM NO.	ITEM DESCRIPTION	UNIT	QUANTITY
20800150	1	TRENCH BACKFILL	CU YD	5
XX007278	2	PARKWAY RESTORATION	SQ YD	376
28000510	3	INLET FILTERS	EACH	28
40600100	4	BITUMINOUS MATERIALS (PRIME COAT)	GALLON	854
40600300	5	AGGREGATE (PRIME COAT)	TON	17
40600625	6	LEVELING BINDER (MACHINE METHOD), N50 (IL - 9.5mm)	TON	442
40603335	7	HOT-MIX ASPHALT SURFACE COURSE, MIX "D", N50 (IL - 9.5mm)	TON	1076
44000198	8	HOT-MIX ASPHALT SURFACE REMOVAL, VARIABLE DEPTH	SQ YD	8390
40600982	9	HOT-MIX ASPHALT SURFACE REMOVAL-BUTT JOINT	SQ YD	148
44000500	10	COMBINATION CURB AND GUTTER REMOVAL	FOOT	376
XX007984	11	CLASS D PATCHES, SPECIAL	TON	290
550A0050	12	STORM SEWERS, CLASS A, TYPE 1 12"	FOOT	20
XX003136	13	CATCH BASIN, TYPE C	EACH	4
XX008206	14	SPECIAL FRAME AND GRATE NO. 1	EACH	28
XX007985	15	SPECIAL FRAME, CLOSED LID	EACH	19
60250200	16	CATCH BASINS TO BE ADJUSTED	EACH	24
60252800	17	CATCH BASINS TO BE RECONSTRUCTED	EACH	4
60255500	18	MANHOLES TO BE ADJUSTED	EACH	17
60257900	19	MANHOLES TO BE RECONSTRUCTED	EACH	2
60603800	20	COMBINATION CONCRETE CURB AND GUTTER, TYPE B-6.12	FOOT	376
67100100	21	MOBILIZATION	L SUM	1
70101800	22	TRAFFIC CONTROL AND PROTECTION, (SPECIAL)	L SUM	1
70300100	23	SHORT-TERM PAVEMENT MARKING	FOOT	1000
* 78000100	24	THERMOPLASTIC PAVEMENT MARKING - LETTERS AND SYMBOLS	SQ FT	62
* 78000200	25	THERMOPLASTIC PAVEMENT MARKING - LINE 4"	FOOT	3865
* 78000400	26	THERMOPLASTIC PAVEMENT MARKING - LINE 6"	FOOT	490
* 78000600	27	THERMOPLASTIC PAVEMENT MARKING - LINE 12"	FOOT	247
* 78000650	28	THERMOPLASTIC PAVEMENT MARKING - LINE 24"	FOOT	107
X0322256	29	TEMPORARY INFORMATION SIGNING	SQ FT	52

* SPECIALTY ITEMS

F.A.U. ROUTE	MUNICIPAL SECTION	COUNTY	TOTAL SHEET SHOTS. NO.
043	08-00108-00-RS	McHENRY	6 2
GENERAL NOTES AND SUMMARY OF QUANTITIES			
F.H.W.A. REG.5 ILLINOIS PROJECT M-9003(181)			

LEGEND

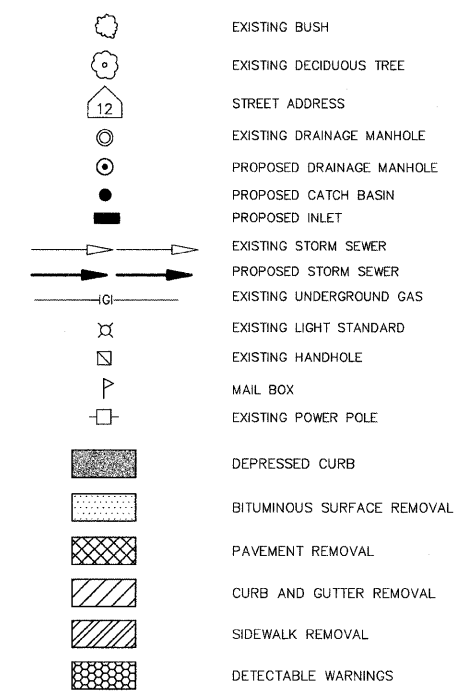

SEWER STRUCTURE AND PIPE NOTATION

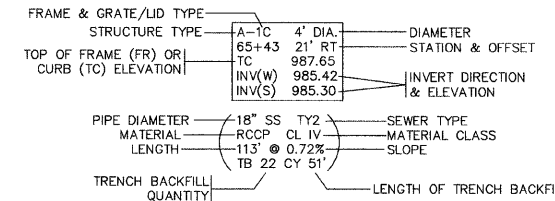

STRUCTURE ADJUSTMENT/RECONSTRUCTION/REMOVAL NOTATION

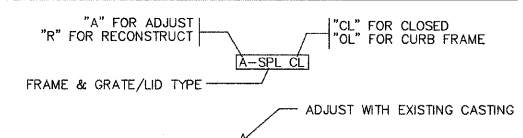

PROPOSED TYPICAL SECTION - CALHOUN STREET
STATION 17+25 TO STATION 39+12

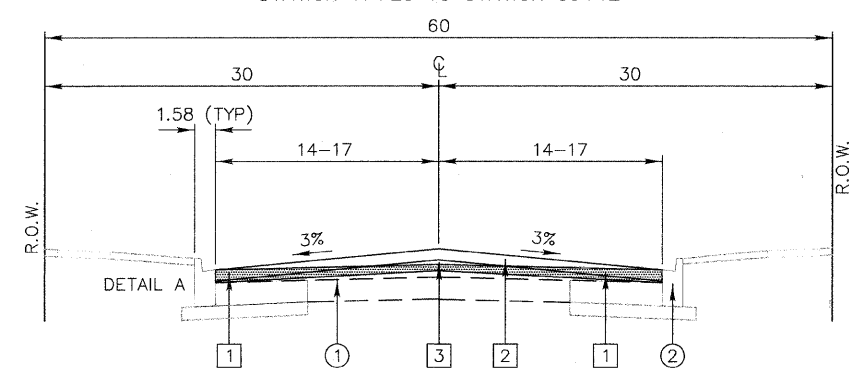

- ① EXISTING BITUMINOUS PAVEMENT AND WEARING SURFACE
- ② EXISTING COMBINATION CURB & GUTTER, B-6.12
- 1 HMA SURFACE REMOVAL, VARIABLE DEPTH
- 2 HMA SURFACE COURSE, MIX "D" N50, (2%)
- 3 LEVELING BINDER (MACHINE METHOD), N50 (3/4" AND VARIES)

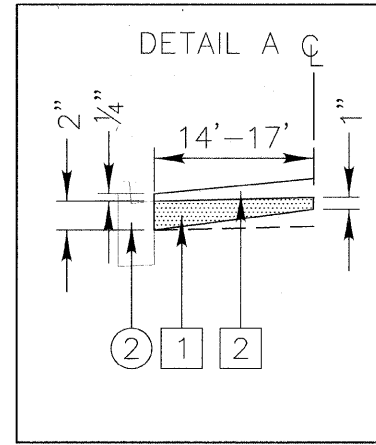

HOT-MIX ASPHALT SELECTION CHART

MIXTURE TYPE	AC TYPE	PERCENT AIR VOIDS
HMA SURFACE COURSE, MIX D, N50 (IL-9.5mm)	PG 64-22	4% @ 50 GYR.
LEVELING BINDER (MACHINE METHOD), N50 (IL-9.5mm)	PG 64-22 *	4% @ 50 GYR.
CLASS D PATCHES, SPECIAL **	PG 64-22 *	4% @ 70 GYR.

THE UNIT WEIGHT USED TO CALCULATE ALL HMA SURFACE MIXTURE QUANTITIES IS 112 LBS/SQ.IN.
* WHEN RAP EXCEEDS 20%, THE NEW ASPHALT BINDER IN THE MIX SHALL BE PG 58-22.
** (HMA BINDER IL-19mm)

F.A.U. ROUTE	MUNICIPAL SECTION	COUNTY	TOTAL SHEETS	SHEET NO.
043	08-00108-00-RS	McHENRY	6	3
CALHOUN STREET PLAN				
F.H.W.A. REG.5 ILLINOIS PROJECT M-9003(181)				
CONTRACT NO. 63168				

CLASS D PATCHES, SPECIAL				
ADDRESS / LOCATION	FROM SIDESTREET	TO SIDESTREET	W. BOUND (SQ FT)	E. BOUND (SQ FT)
Station 17+25 to Station 19+77	RR	Seminary	13' x 14'	15' x 28'
			9' x 14'	9' x 14'
			20' x 14'	6' x 28'
			6' x 14'	26' x 7'
			8' x 14'	
SEQuad of Seminary				
				15' x 5'
				(15' x 15')/2
	Seminary	Douglas		
430			17' x 11'	
440			11' x 5'	
505			16' x 7'	
	Douglas	Nebraska		
521 to 523			150' x 7'	
523 to 529			44' x 5'	
529			45' x 7'	
	Nebraska	Irving		
605			27' x 5'	
605			23' x 5'	
636 to 638				19' x 6'
				7' x 3'
	Irving	47		
667 to 671			19' x 18'	5' x 4'
722			13' x 28'	
722				12' x 16'
722				32' x 11'
			42' x 15'	
SUBTOTALS (SQ FT)			3845	952
TOTAL (SQ YD)				691

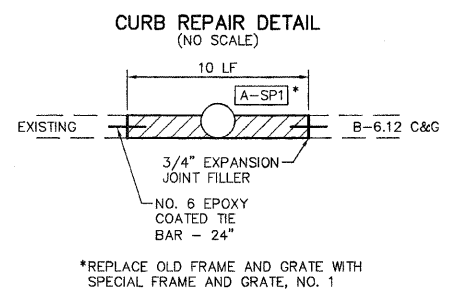
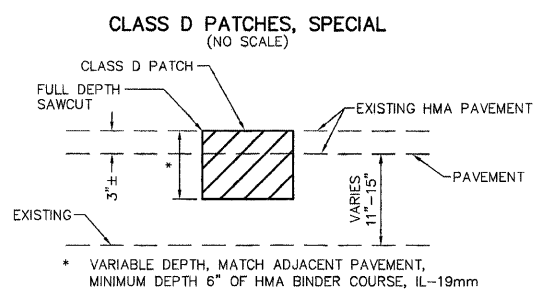
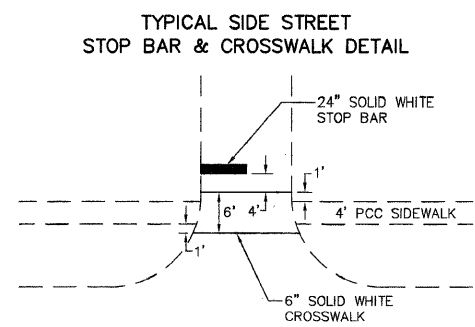

PROJECT BEGINS STATION 17+25

PROJECT ENDS STATION 39+12

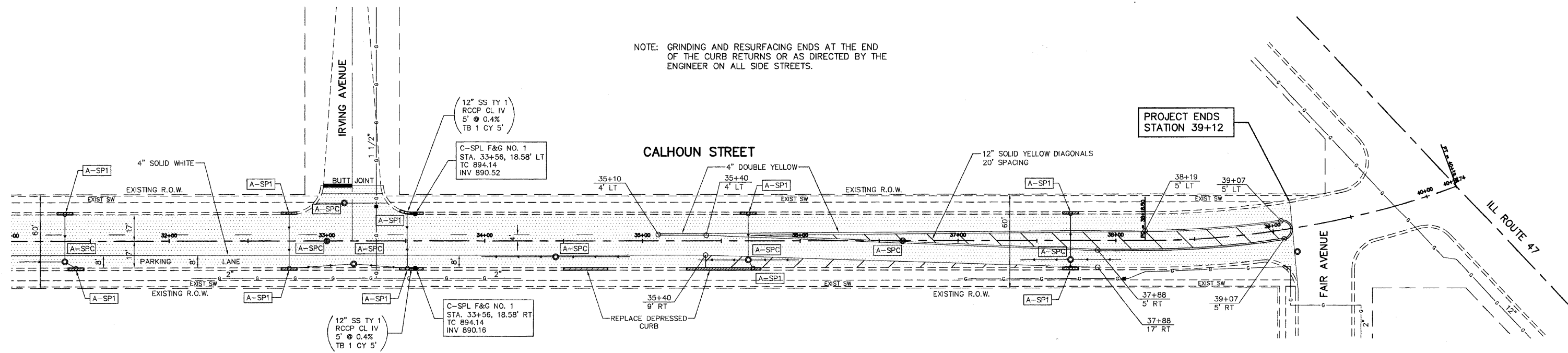
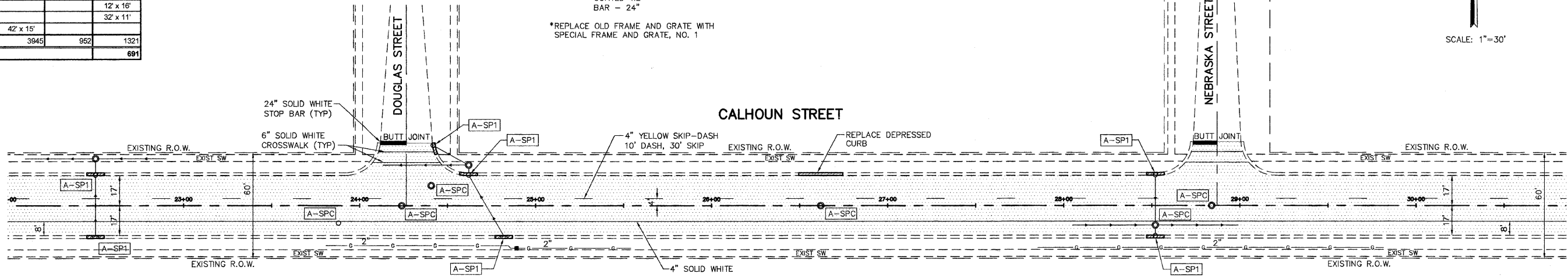
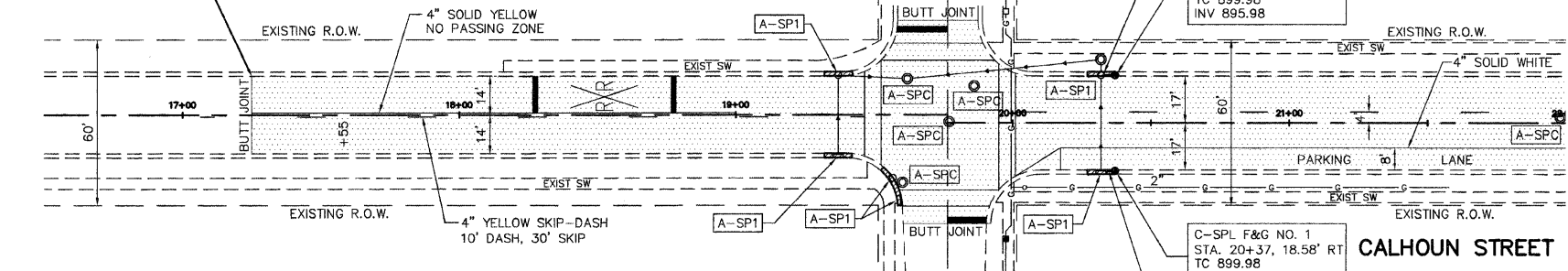

NOTE: GRINDING AND RESURFACING ENDS AT THE END OF THE CURB RETURNS OR AS DIRECTED BY THE ENGINEER ON ALL SIDE STREETS.

NOTE: GRINDING AND RESURFACING ENDS AT THE END OF THE CURB RETURNS OR AS DIRECTED BY THE ENGINEER ON ALL SIDE STREETS.

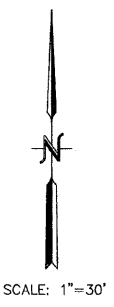

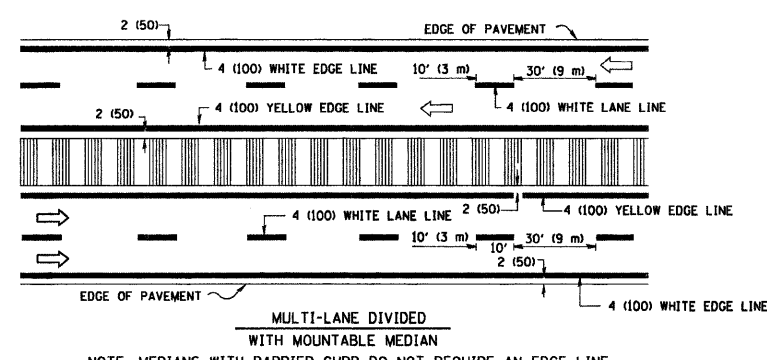
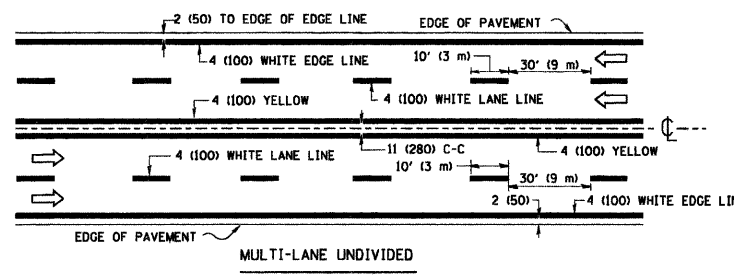
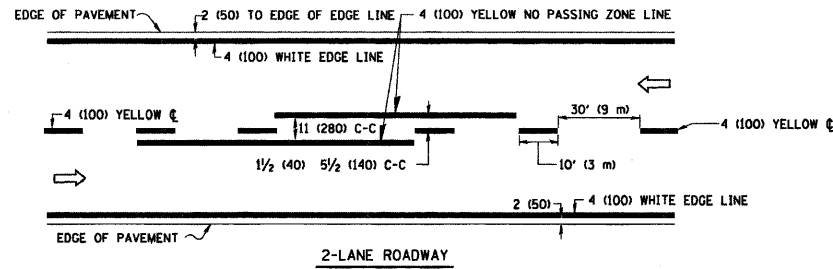

NOTE: MEDIANS WITH BARRIER CURB DO NOT REQUIRE AN EDGE LINE
TYPICAL LANE AND EDGE LINE MARKING

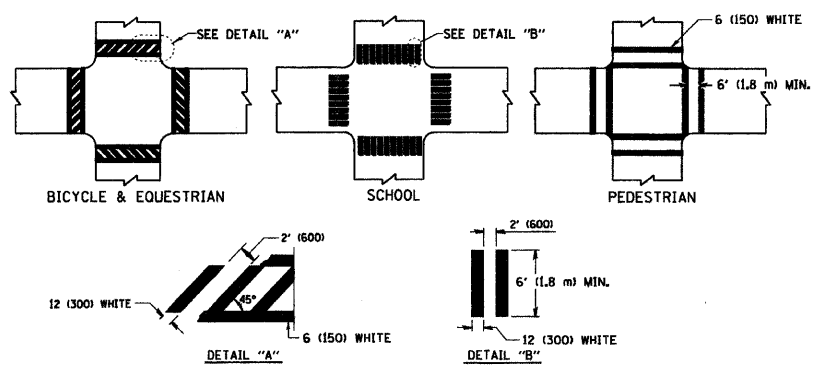

TYPICAL CROSSWALK MARKING

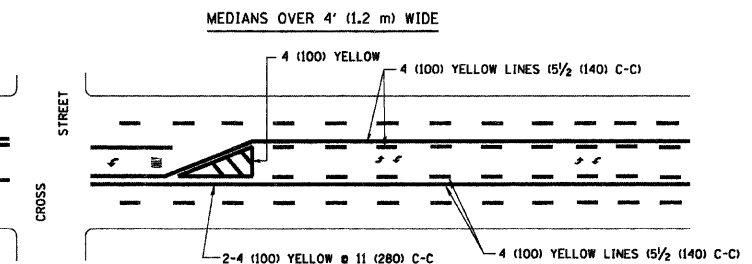
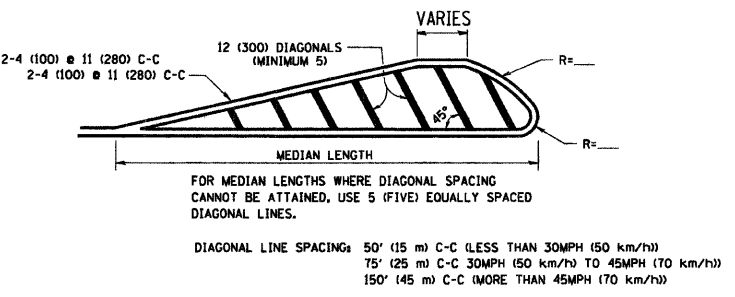
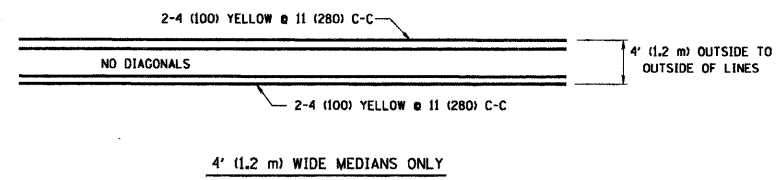

A MINIMUM OF TWO PAIRS OF TURN ARROWS SHALL BE USED, WHITE IN COLOR. ADDITIONAL PAIRS SHALL BE PLACED AT 200' (60 m) TO 300' (90 m) INTERVALS.

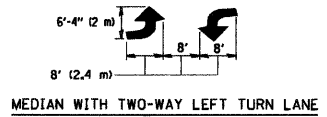

TYPICAL PAINTED MEDIAN MARKING

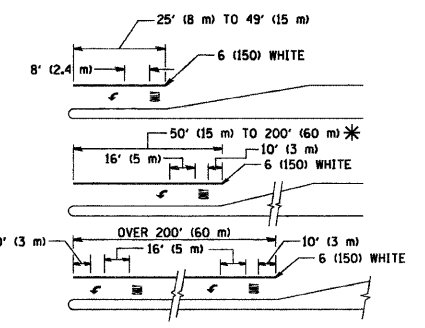

FULL SIZE LETTERS 8' (2.4 m) AND ARROWS SHALL BE USED.
AREA = 15.6 SQ. FT. (1.5 m²) AREA = 20.8 SQ. FT. (1.9 m²)
* TURN LANES IN EXCESS OF 400' (120 m) IN LENGTH MAY HAVE AN ADDITIONAL SET OF ARROW - "ONLY" INSTALLED MIDWAY BETWEEN THE OTHER TWO SETS OF ARROW - "ONLY".

TYPICAL TURN LANE MARKING

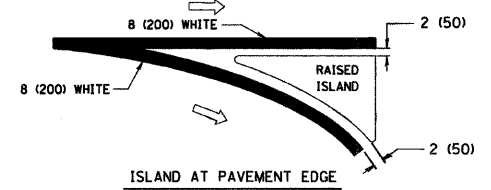
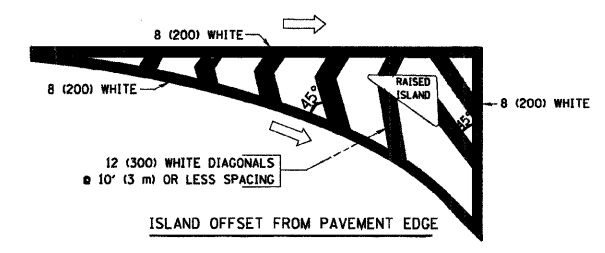

TYPICAL ISLAND MARKING

TYPE OF MARKING	WIDTH OF LINE	PATTERN	COLOR	SPACING / REMARKS
CENTERLINE ON 2 LANE PAVEMENT	4 (100)	SKIP-DASH	YELLOW	10' (3 m) LINE WITH 30' (9 m) SPACE
CENTERLINE ON MULTI-LANE UNDIVIDED PAVEMENT	2 @ 4 (100)	SOLID	YELLOW	11 (280) C-C
NO PASSING ZONE LINES FOR ONE DIRECTION FOR BOTH DIRECTIONS	4 (100) 2 @ 4 (100)	SOLID SOLID	YELLOW YELLOW	5 1/2 (140) C-C FROM SKIP-DASH CENTERLINE 11 (280) C-C OMIT SKIP-DASH CENTERLINE BETWEEN
LANE LINES	4 (100) 5 (125) ON FREEWAYS	SKIP-DASH SKIP-DASH	WHITE WHITE	10' (3 m) LINE WITH 30' (9 m) SPACE
DOTTED LINES (EXTENSIONS OF CENTER, LANE OR TURN LANE MARKINGS)	SAME AS LINE BEING EXTENDED	SKIP-DASH	SAME AS LINE BEING EXTENDED	2' (600) LINE WITH 6' (1.8 m) SPACE
EDGE LINES	4 (100)	SOLID	YELLOW-LEFT WHITE-RIGHT	OUTLINE MOUNTABLE MEDIANS IN YELLOW; EDGE LINES ARE NOT USED NEXT TO BARRIER CURB
TURN LANE MARKINGS	6 (150) LINE; FULL SIZE LETTERS & SYMBOLS (8' (2.4m))	SOLID	WHITE	SEE TYPICAL TURN LANE MARKING DETAIL
TWO WAY LEFT TURN MARKING	2 @ 4 (100) EACH DIRECTION 8' (2.4m) LEFT ARROW	SKIP-DASH AND SOLID IN PAIRS	YELLOW WHITE	10' (3 m) LINE WITH 30' (9 m) SPACE FOR SKIP-DASH; 5 1/2 (140) C-C BETWEEN SOLID LINE AND SKIP-DASH LINE SEE TYPICAL TWO-WAY LEFT TURN MARKING DETAIL
CROSSWALK LINES (PEDESTRIAN) A. DIAGONALS (BIKE & EQUESTRIAN) B. LONGITUDINAL BARS (SCHOOL)	2 @ 6 (150) 12 (300) @ 45° 12 (300) @ 90°	SOLID SOLID SOLID	WHITE WHITE WHITE	NOT LESS THAN 6' (1.8 m) APART 2' (600) APART SEE TYPICAL CROSSWALK MARKING DETAILS.
STOP LINES	24 (600)	SOLID	WHITE	PLACE 4' (1.2 m) IN ADVANCE OF AND PARALLEL TO CROSSWALK, IF PRESENT. OTHERWISE, PLACE AT DESIRED STOPPING POINT. PARALLEL TO CROSSROAD CENTERLINE, WHERE POSSIBLE
PAINTED MEDIANS	2 @ 4 (100) WITH 12 (300) DIAGONALS @ 45° NO DIAGONALS USED FOR 4' (1.2 m) WIDE MEDIANS	SOLID	YELLOW; TWO WAY TRAFFIC WHITE; ONE WAY TRAFFIC	11 (280) C-C FOR THE DOUBLE LINE SEE TYPICAL PAINTED MEDIAN MARKING.
GORE MARKING AND CHANNELIZING LINES	8 (200) WITH 12 (300) DIAGONALS @ 45°	SOLID	WHITE	DIAGONALS; 15' (4.5 m) C-C (LESS THAN 30MPH (50 km/h)) 20' (6 m) C-C 30MPH (50 km/h) TO 45MPH (70 km/h) 30' (9 m) C-C (OVER 45MPH (70 km/h))
RAILROAD CROSSING	24 (600) TRANSVERSE LINES; "RR" IS 6' (1.8 m) LETTERS; 16 (400) LINE FOR "X"	SOLID	WHITE	SEE STATE STANDARD 780001 AREA OF: "RR"=3.6 SQ. FT. (0.33 m ²) EACH "X"=54.0 SQ. FT. (5.0 m ²)
SHOULDER DIAGONALS	12 (300) @ 45°	SOLID	WHITE - RIGHT YELLOW - LEFT	50' (15 m) C-C (LESS THAN 30MPH (50 km/h)) 75' (25 m) C-C (30 MPH (50 km/h) TO 45MPH (70 km/h)) 150' (45 m) C-C (OVER 45MPH (70 km/h))

FOR FURTHER DETAILS ON PAVEMENT MARKING REFER TO STANDARD SPECIFICATIONS FOR ROAD AND BRIDGE CONSTRUCTION AND STATE STANDARD 780001.

All dimensions are in inches (millimeters) unless otherwise shown.

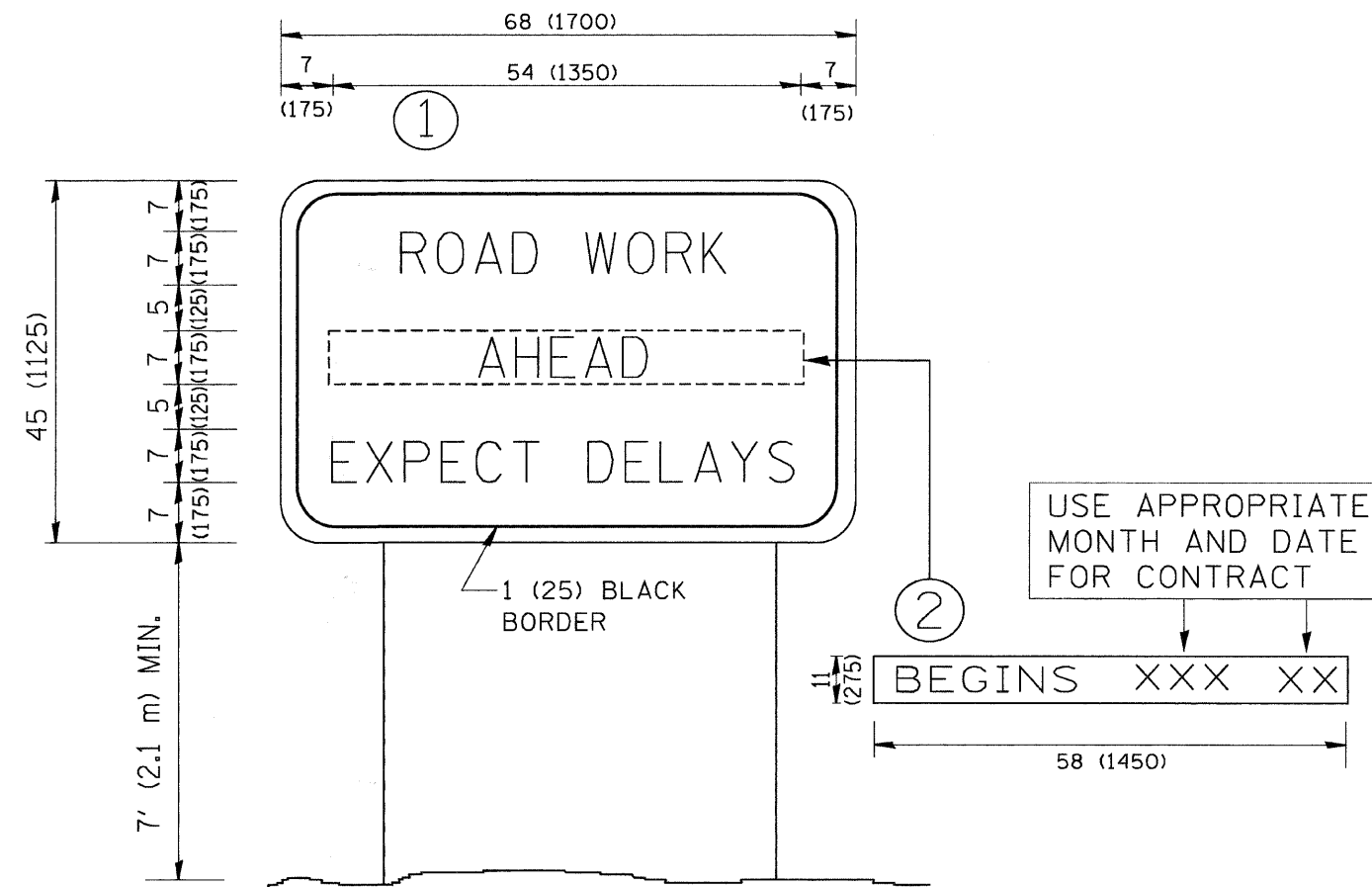

NOTES:

1. USE BLACK LETTERING ON ORANGE BACKGROUND.
2. ERECT SIGNS IN ADVANCE OF THE LOCATION FOR THE "ROAD CONSTRUCTION AHEAD" SIGN AT LOCATIONS AS DIRECTED BY THE ENGINEER.
3. ERECT SIGN ① WITH INSTALLED PANEL ② ONE WEEK PRIOR TO THE START OF CONSTRUCTION.
4. REMOVE PANEL ② SOON AFTER THE START OF CONSTRUCTION.
5. SEE SPECIAL PROVISION FOR "TEMPORARY INFORMATION SIGNING" FOR ADDITIONAL INFORMATION.
6. ONE SIGN ASSEMBLY EQUALS 25.70 SQ. FT. (2.3 SQ. M.)
7. SHALL BE PAID FOR AS TEMPORARY INFORMATION SIGNING.

ALL DIMENSIONS ARE IN INCHES (MILLIMETERS) UNLESS OTHERWISE SHOWN.

FILE NAME = M:\diststd\22x34\tc22.dgn	USER NAME = gaglianobt	DESIGNED -	REVISED - R. MIRS 09-15-97	STATE OF ILLINOIS DEPARTMENT OF TRANSPORTATION	ARTERIAL ROAD INFORMATION SIGN	F.A.J. RTE.	SECTION	COUNTY	TOTAL SHEETS	SHEET NO.	
		DRAWN -	REVISED - R. MIRS 12-11-97			043	08-00108-00-RS	McHENRY	6	5	
		PLOT SCALE = 50.000' / IN.	REVISED - T. RAMMACHER 02-02-99			TC-22		CONTRACT NO. 63168			
		PLOT DATE = 1/4/2008	REVISED - C. JUCIUS 01-31-07			SCALE: NONE	SHEET NO. 1 OF 1 SHEETS	STA.	TO STA.	FED. ROAD DIST. NO. 1 ILLINOIS FED. AID PROJECT	

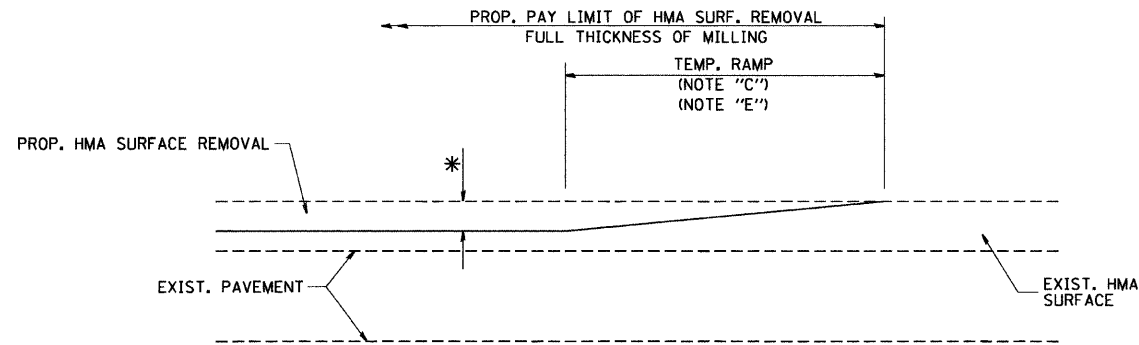

MILLED TEMPORARY RAMP
(FOR BUTT JOINT AND HMA TAPER SEE DETAIL BELOW)

OPTION 1

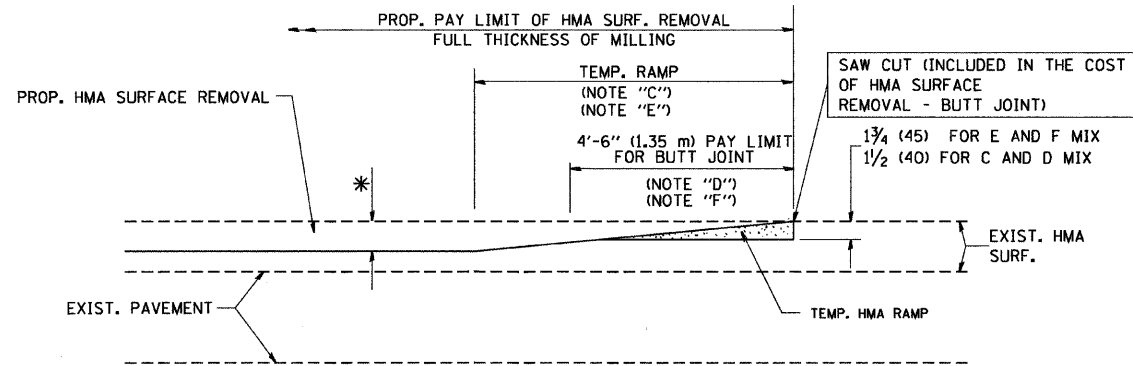

HMA CONSTRUCTED TEMPORARY RAMP
(FOR BUTT JOINT AND HMA TAPER SEE DETAIL BELOW)

OPTION 2

TYPICAL TEMPORARY RAMP

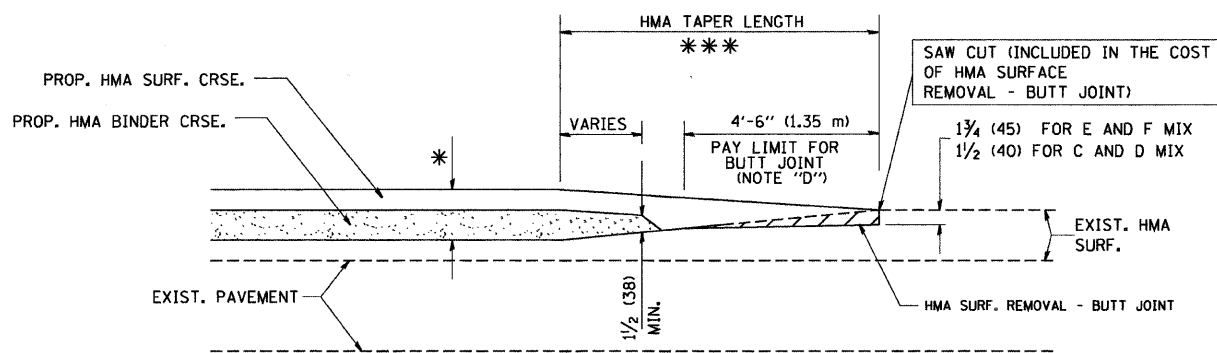

TYPICAL BUTT JOINT AND HMA TAPER
FOR MILLING AND RESURFACING

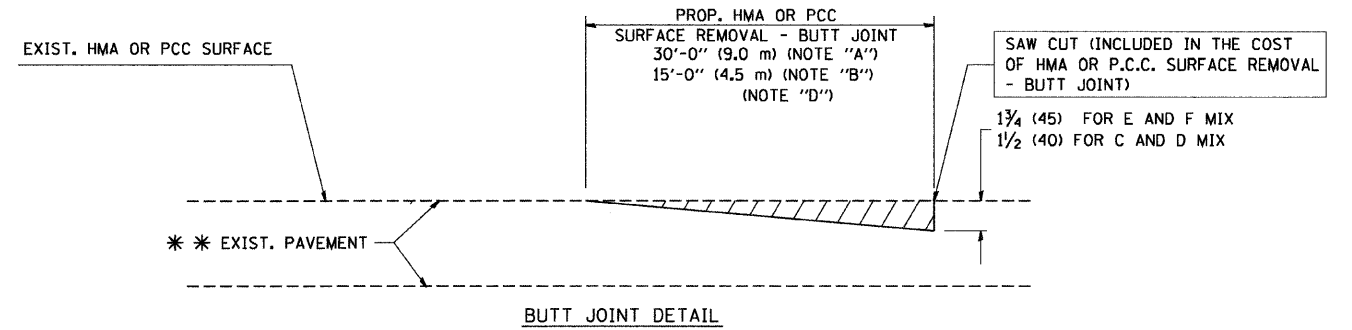

BUTT JOINT DETAIL

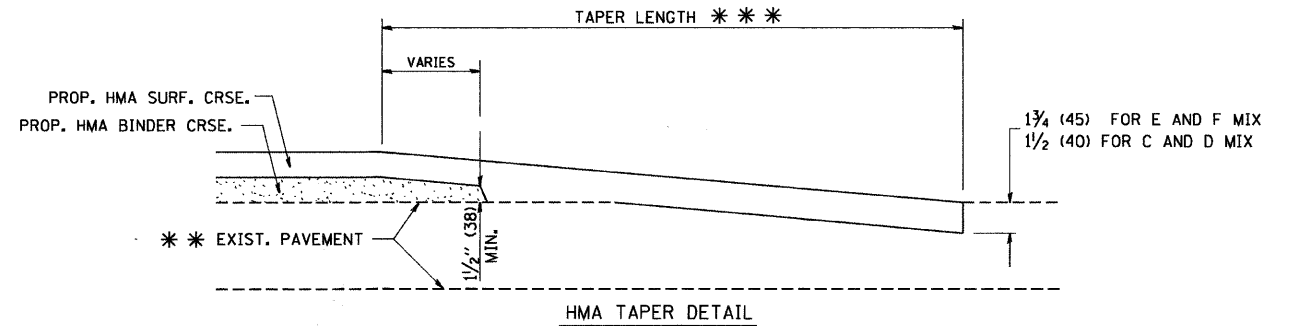

HMA TAPER DETAIL

TYPICAL BUTT JOINT AND HMA TAPER
FOR RESURFACING ONLY

** PC CONCRETE, HMA OR HMA RESURFACED PAVEMENT.

NOTES

- A: MAINLINE ROADWAYS AND MAJOR SIDE ROADS.
- B: MINOR SIDE ROADS.
- C: THE TEMP. RAMP SHALL BE CONSTRUCTED IMMEDIATELY UPON REMOVAL OF THE EXISTING HMA SURFACE.
- D: THE BUTT JOINT SHALL BE CONSTRUCTED IMMEDIATELY PRIOR TO PLACING THE PROPOSED HMA COURSES.
- E: TAPER THE TEMP. RAMP AT A RATE OF 3'-0" (900 mm) PER 1 INCH (25 mm) OF MILLING THICKNESS.
- F: INSTALLATION AND REMOVAL OF THE 4'-6" (1.35 m) TEMP. RAMP IS INCLUDED IN COST OF HMA SURFACE REMOVAL - BUTT JOINT
- G: SEE ARTICLE 406.08 AND 406.14 OF THE STANDARD SPECIFICATIONS FOR "HMA AND/OR PCC SURFACE REMOVAL, BUTT JOINT".
- * SEE TYPICAL SECTIONS FOR MILLING THICKNESS.
- ** 20'-0" (6.1 m) PER 1 (25) RESURFACING (NOTE "A")
10'-0" (3.0 m) PER 1 (25) RESURFACING (NOTE "B")

BASIS OF PAYMENT:

THE BUTT JOINT WILL BE PAID FOR AT THE CONTRACT UNIT PRICE PER SQUARE YARD (SQUARE METER) FOR "HOT-MIX ASPHALT SURFACE REMOVAL - BUTT JOINT" OR FOR "PORTLAND CEMENT CONCRETE SURFACE REMOVAL - BUTT JOINT".

ALL DIMENSIONS ARE IN INCHES (MILLIMETERS) UNLESS OTHERWISE SHOWN.

FILE NAME = W:\distata\22x34\bd32.dgn	USER NAME = gaglianobt	DESIGNED - M. DE YONG	REVISED - R. SHAH 10-25-94
		DRAWN -	REVISED - A. ABBAS 03-21-97
	PLOT SCALE = 50.0000' / IN.	CHECKED -	REVISED - M. GOMEZ 04-06-01
	PLOT DATE = 1/4/2008	DATE - 06-13-90	REVISED - R. BORO 01-01-07

STATE OF ILLINOIS
DEPARTMENT OF TRANSPORTATION

BUTT JOINT AND HMA TAPER DETAILS			
SCALE: NONE	SHEET NO. 1 OF 1 SHEETS	STA.	TO STA.

F.A.J. RTE.	SECTION	COUNTY	TOTAL SHEETS	SHEET NO.
043	08-00108-00-RS	McHENRY	6	6
BD400-05 BD32			CONTRACT NO. 63168	
FED. ROAD DIST. NO. 1 ILLINOIS FED. AID PROJECT				