

**EXISTING TYPICAL CROSS SECTION
STA 10+25 TO STA 49+71**

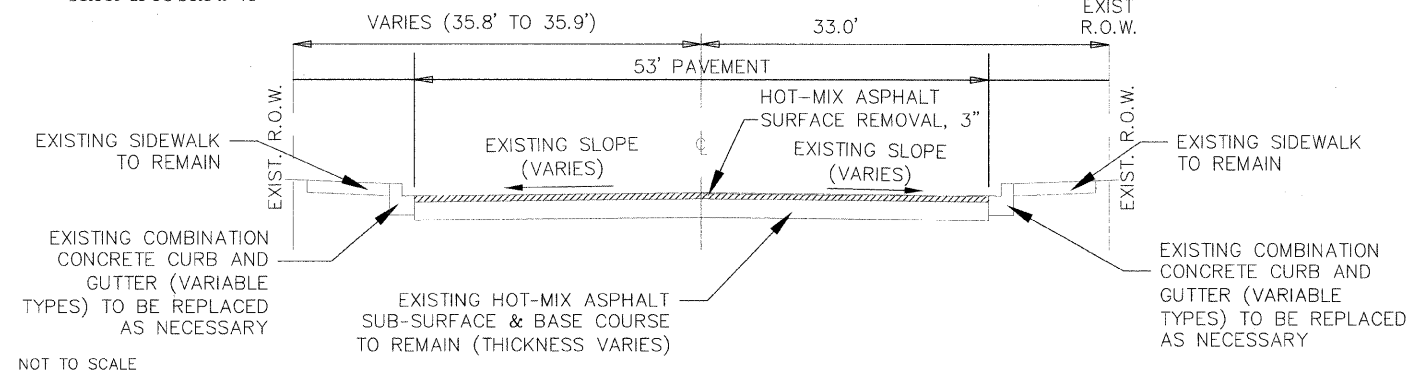

NOT TO SCALE

**PROPOSED TYPICAL CROSS SECTION
STA 10+25 TO STA 49+71**

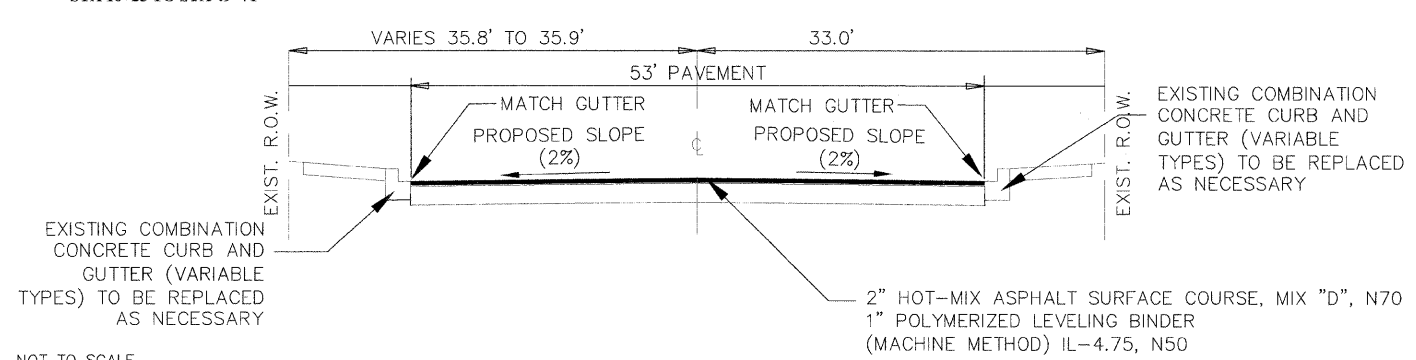

NOT TO SCALE

**EXISTING TYPICAL CROSS SECTION
STA 49+71 TO STA 94+50**

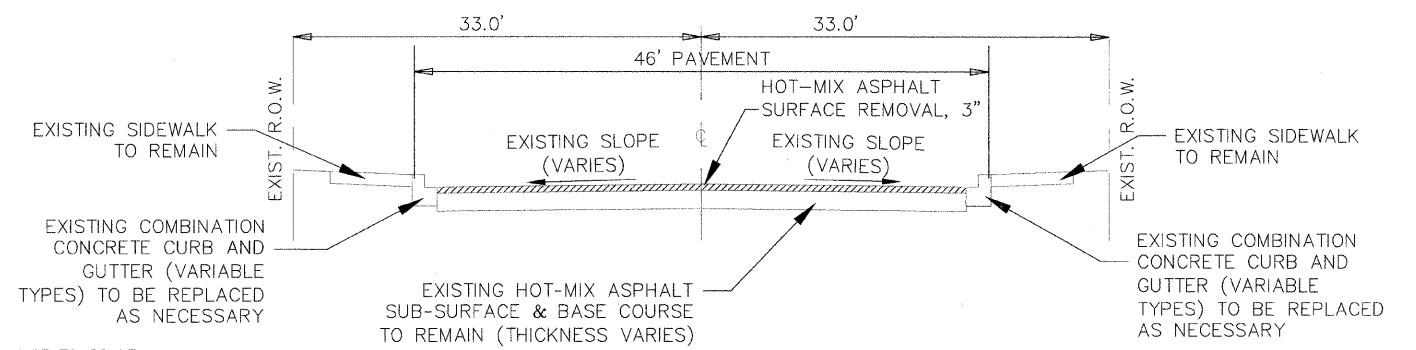

NOT TO SCALE

**PROPOSED TYPICAL CROSS SECTION
STA 49+71 TO STA 94+50**

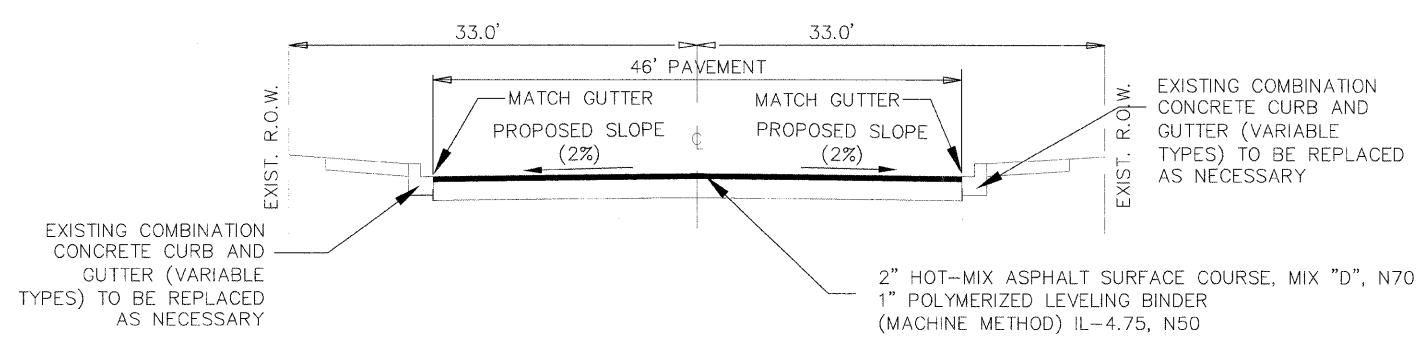

NOT TO SCALE

GENERAL NOTES

THE CONTRACTOR SHALL COORDINATE CONSTRUCTION ACTIVITIES WITH UTILITY COMPANIES AND THE VILLAGE OF VILLA PARK. BEFORE STARTING ANY EXCAVATING THE CONTRACTOR SHALL CONTACT "JULIE" AT (800) 892-0123 FOR FIELD LOCATIONS OF BURIED ELECTRIC, TELEPHONE GAS, OR OTHER FACILITIES. (48 HOUR NOTIFICATION IS REQUIRED)

TEN FOOT (10') TRANSITIONS SHALL BE USED TO MATCH PROPOSED CURB AND GUTTER AND MEDIAN ITEMS OF WORK TO EXISTING CURBS AND GUTTERS AND MEDIANS IN THE FIELD, UNLESS OTHERWISE SHOWN, THE TRANSITIONS SHALL BE PAID FOR AT THE CONTRACT UNIT PRICE FOR THE PROPOSED ITEMS OF WORK SPECIFIED.

FULL DEPTH SAW CUT SHALL BE PERFORMED PRIOR TO REMOVAL OF COMBINATION CONCRETE CURB & GUTTER. FULL DEPTH SAW CUT WILL BE INCIDENTAL TO COMBINATION CONCRETE CURB AND GUTTER REMOVAL AND REPLACEMENT ITEM.

RESTORATION BEHIND INSTALLED CURB & GUTTER SHALL BE CONSIDERED INCIDENTAL TO COMBINATION CONCRETE CURB AND GUTTER REMOVAL AND REPLACEMENT ITEM.

BARRICADES: THE CONTRACTOR SHALL PROVIDE AND INSTALL TWO (2) WEIGHTED SANDBAGS ON EACH TYPE I OR TYPE II BARRICADE USED. ONE (1) WEIGHTED SAND BAG SHALL BE USED ACROSS EACH BOTTOM RAIL.

WHEN MILLED PAVEMENT IS OPEN TO TRAFFIC THE MAXIMUM GRADE DIFFERENTIAL BETWEEN PASSES OF THE MILLING MACHINE SHALL NOT EXCEED ONE AND ONE-HALF INCHES (1½") WHERE THE SPEED LIMIT IS FORTY-FIVE MILES PER HOUR (45 MPH) OR LESS AND ONE INCH (1") WHERE THE SPEED LIMIT IS GREATER THAN FORTY-FIVE MILES PER HOUR (45 MPH). WITH WRITTEN APPROVAL FROM THE ENGINEER, A MAXIMUM GRADE DIFFERENTIAL OF THREE INCHES (3") MAY BE ALLOWED IF THE EDGE OF THE MILLING IS SLOPED A MINIMUM 1:3 (V:H).

HOT-MIX ASPHALT SURFACE REMOVAL - BUTT JOINTS WILL BE INSTALLED AT THE ENDS OF ALL RESURFACING (WHERE RESURFACING MEETS EXISTING PAVEMENT), IN ACCORDANCE WITH THE "BUTT JOINT AND HMA TAPER DETAILS" SHEET INCLUDED IN THE PLANS, UNLESS OTHERWISE SPECIFIED.

HOT-MIX ASPHALT MIXTURE REQUIREMENTS		
MIXTURE TYPE	AC TYPE	AIR VOIDS
HOT-MIX ASPHALT SURFACE COURSE, MIX "D", N70	PG 64-22	4% @ 70 Gyr.
POLYMERIZED LEVELING BINDER (MACHINE METHOD), IL-4.75, N50	SBS/SBR PG 76-28/-22	4% @ 50 Gyr.
CLASS D PATCHES (HMA BINDER IL-19 mm)	PG 64-22 *	4% @ 70 Gyr.

THE UNIT WEIGHT USED TO CALCULATE ALL HMA SURFACE MIXTURE QUANTITIES IS 112 LBS/SQ YD/IN.

* WHEN RAP EXCEEDS 20%, THE NEW ASPHALT BINDER IN THE MIX SHALL BE PG 58-22.



VILLAGE OF VILLA PARK
ENGINEERING DIVISION
20 SOUTH ARDMORE AVENUE
VILLA PARK, ILLINOIS 60181-2696

PHONE (630) 834-8505
FAX (630) 834-8509

REVISIONS	
NAME	DATE
PER IDOT REVIEW	03/27/09

VILLAGE OF VILLA PARK, ILLINOIS
**GENERAL NOTES, TYPICAL SECTIONS
& HMA MIX REQUIREMENTS CHART**
ST. CHARLES ROAD
SHEET 1 OF 1

SCALE: NOTED
DATE: 11/30/2008
DRAWN BY: C.C.
CHECKED BY: S.K.