

DATE  
BY  
SUBMITTED  
PLOTTED  
ALIGNMENT CHECKED  
NOTE BOOK  
FILE NAME  
NO.

DATE  
BY  
SUBMITTED  
PLOTTED  
ALIGNMENT CHECKED  
NOTE BOOK  
FILE NAME  
NO.

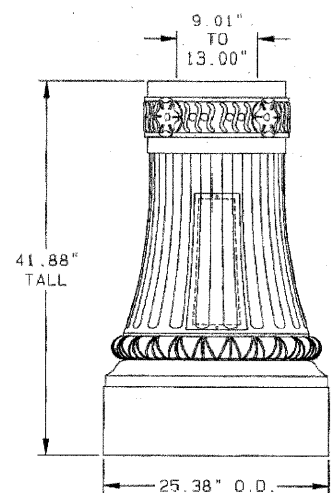

DETAIL 9 HN25AB DECORATIVE BASE

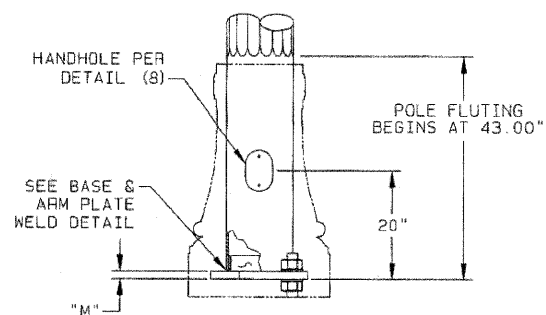

DETAIL 10 HN25AB POLE BASE

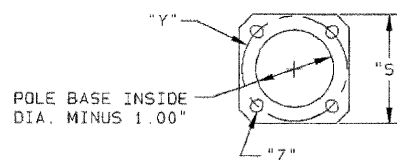

DETAIL 11 ANCHOR BOLT

(4) - ANCHOR BOLTS, GALVANIZED THE FULL LENGTH. EACH BOLT FURNISHED WITH (2) - HEX NUTS, (2) - FLAT WASHERS AND (1) - LOCKWASHER.

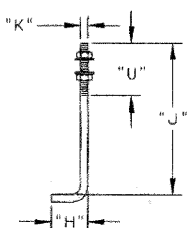

NOTES:

- POLE AND ARM SHAFTS 13.00" AND SMALLER—CONFORMS TO ASTM DESIGNATION: A595 GR. A WITH 55,000 P.S.I. MINIMUM YIELD STRENGTH. LINEAR TAPER—0.14"/FT. POLE AND ARM SHAFTS LARGER THAN 13.00"—CONFORMS TO ASTM DESIGNATION: M-223 A572 GR. 65 WITH A 65,000 P.S.I. MINIMUM YIELD STRENGTH. LINEAR TAPER—0.14"/FT.
- BASE PLATE AND SIMPLEX PLATES—CONFORM TO AASHTO M-183 (ASTM: A36).
- ANCHOR BOLTS—ALL STRUCTURES: ASTM F1554 GR.55 55,000 P.S.I. MINIMUM YIELD STRENGTH. (AASHTO M314)
- TRAFFIC SIGNAL ARM END CAP SECURED IN PLACE WITH 3 STAINLESS STEEL SET SCREWS. (TRAFFIC SIGNAL ARM END CAP PROVIDED WITH (2) ADDITIONAL STAINLESS STEEL HEX BOLTS).
- ALL NON-STAINLESS THREADED FASTENERS TO BE HOT DIP GALVANIZED TO ASTM DESIGNATION: A153 (AASHTO M232).
- SIMPLEX CONNECTING BOLTS—ASTM DESIGNATION: A325 (M164) GALVANIZED TO ASTM DESIGNATION: A153 LUBRICATE THREADS IN FIELD IF NECESSARY BEFORE INSTALLATION.
- ALL VEHICULAR AND/OR PEDESTRIAN SIGNAL LIGHTS AND NECESSARY HARDWARE FOR ATTACHMENT TO BE FIELD LOCATED AND FURNISHED BY OTHERS.
- POLES AND ARMS TO BE GALVANIZED TO ASTM DESIGNATION: A123 (AASHTO M111). ACCESSORIES TO BE HOT DIP GALVANIZED TO ASTM DESIGNATION: A153 (AASHTO M232).
- ACCESS HOLES IN ARMS AT SIGNALS TO BE FIELD DRILLED BY CONTRACTOR—LOCATED AS SHOWN IN PLANS.
- LUMINAIRE ARM SHAFT CONFORMS TO 2" SCHEDULE 40 PIPE W/ 36,000 PSI MIN. YIELD STRENGTH.
- SHAFT GAUGE OR THICKNESS ARE AS FOLLOWS: 11 GA. = 0.1196", 7 GA. = 0.1793", 5 GA. = 0.2092", 3 GA. = 0.2391", AND 2" SCHED.40 PIPE = 0.154".

LOADING AND ALLOWABLE STRESS CRITERIA: 1994 AASHTO "STANDARD SPECIFICATIONS FOR STRUCTURAL SUPPORTS FOR SIGNS, LUMINAIRES AND TRAFFIC SIGNALS".

STATE OF ILLINOIS

GENERAL NOTES

POLE AND SIGNAL ARM DATA - OPTION 1

POLE TUBE			POLE BASE				ANCHOR BOLT			SIGNAL ARM TUBE			MAXIMUM LUMINAIRE ARM SPAN (FT)		
BASE DIA. (IN)	TOP DIA. (IN)	LENGTH (FT)	GAUGE OR THK. (IN)	SQUARE "S" (IN)	BOLT CIRCLE "Y" (IN)	THK. "M" (IN)	HOLE / SLOT "Z" (IN)	DIA. "K" (IN)	LENGTH "J" (IN)	HOOK "H" (IN)	THREAD LENGTH "U" (IN)	FIXED END DIA. (IN)	GAUGE OR THICK (IN)	SPAN (FT)	
12.50	8.65	27.50	5	17.00	17.00	1.50	1.75	1.50	54.00	6.00	8.00	9.00	7	20.00	8.00

POLE AND SIGNAL ARM DATA - OPTION 2

POLE TUBE			POLE BASE				ANCHOR BOLT			SIGNAL ARM TUBE			MAXIMUM LUMINAIRE ARM SPAN (FT)		
BASE DIA. (IN)	TOP DIA. (IN)	LENGTH (FT)	GAUGE OR THK. (IN)	SQUARE "S" (IN)	BOLT CIRCLE "Y" (IN)	THK. "M" (IN)	HOLE / SLOT "Z" (IN)	DIA. "K" (IN)	LENGTH "J" (IN)	HOOK "H" (IN)	THREAD LENGTH "U" (IN)	FIXED END DIA. (IN)	GAUGE OR THICK (IN)	SPAN (FT)	
12.50	8.65	27.50	5	17.00	17.00	1.50	1.75	1.50	54.00	6.00	8.00	8.00	7	20.00	8.00

JOB		VALMONT INDUSTRIES, INC. RESERVES THE RIGHT TO INSTALL VARIOUS, ENGINEER APPROVED, MATERIAL HANGING ACCOMMODATIONS TO FACILITATE THE MANUFACTURING PROCESS.		<b>valmont</b> Valley, NE 68064 (402) 359-2201		ORDER NUMBER: 42203-07 PAGE NUMBER: 2 OF 2 DRAWING NUMBER REV	
TITLE: TRAFFIC SIGNAL STRUCTURES		STATE OF ILLINOIS DEPARTMENT OF TRANSPORTATION		MISCELLANEOUS DETAILS		SECTION: 07-00267-00-TL COUNTY: KANE TOTAL SHEETS: 48 SHEET NO.: 46 CONTRACT NO.: 63152	
FILE NAME =	USER NAME = .USER.	DESIGNED -	REVISED -	SCALE:	SHEET NO. OF SHEETS	STA. TO STA.	FED. ROAD DIST. NO. ILLINOIS FED. AID PROJECT
g:\jobs\smith\2007\070690_aur - traffic	gnals\070690.04_aur new york st. traffic	DRAWN by: BAH	REVISED by:				
PLOT SCALE = #SCALE#	CHECKED APS	DATE -	REVISED -				
PLOT DATE = 4/15/2009							