

PROPOSED TYPICAL SECTION
 STA. 327+27 TO STA. 329+25
 STA. 337+57 TO STA. 341+50
 (LOOKING EAST)

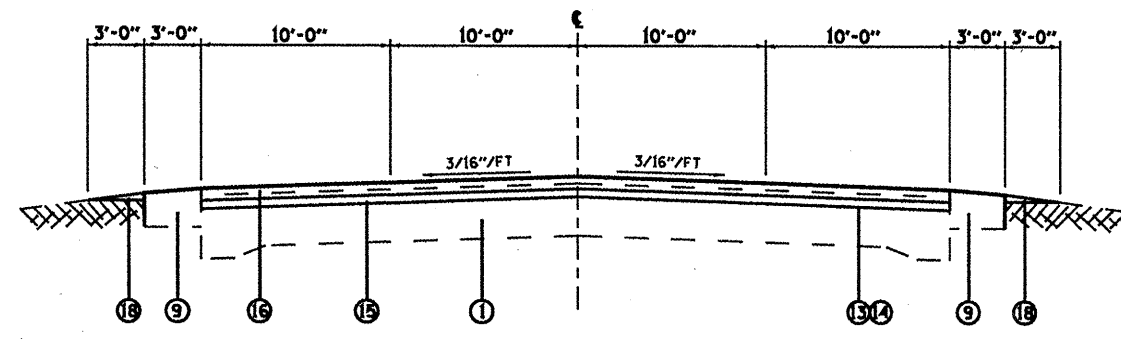

PROPOSED TYPICAL SECTION
 STA. 351+30 TO STA. 356+47
 (LOOKING EAST)

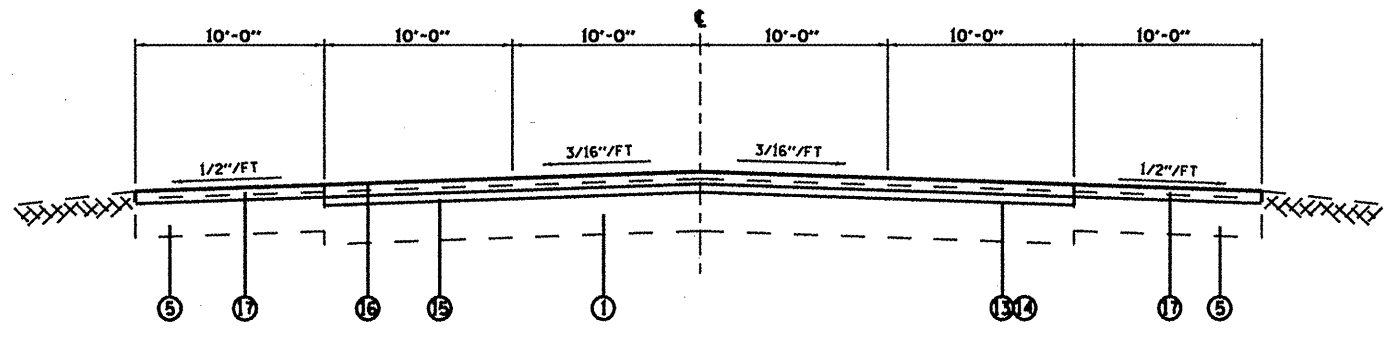

PROPOSED TYPICAL SECTION
 STA. 348+06 TO STA. 351+30
 (LOOKING EAST)

- LEGEND**
- ① EXISTING PCC PAVEMENT
 - ② EXISTING PCC BASE COURSE WIDENING
 - ③ EXISTING HMA LEVELING BINDER
 - ④ EXISTING HMA SURFACE 1 1/2 "
 - ⑤ EXISTING HMA SHOULDER
 - ⑥ EXISTING CONCRETE MEDIAN
 - ⑦ EXISTING COMBINATION CONCRETE CURB AND GUTTER
 - ⑧ EXISTING SIDEROAD
 - ⑨ PAVED SHOULDER REMOVAL/EARTH EXCAVATION/HMA SHOULDER 6"
 - ⑩ HMA SURFACE REMOVAL 1 1/2 "
 - ⑪ HMA SURFACE REMOVAL 3/4 "
 - ⑫ PROPOSED STRIP REFLECTIVE CRACK CONTROL TREATMENT
 - ⑬ PROPOSED BITUMINOUS MATERIAL PRIME COAT
 - ⑭ PROPOSED AGGREGATE PRIME COAT
 - ⑮ PROPOSED LEVELING BINDER (MACHINE METHOD) N70 3/4 "
 - ⑯ PROPOSED HMA SURFACE COURSE MIX "D" N70 1 1/2 "
 - ⑰ PROPOSED HMA SHOULDER (1 1/2")
 - ⑱ PROPOSED AGGREGATE SHOULDER WEDGE
 - ⑲ EXISTING AGGREGATE SHOULDER

FILE NAME *	USER NAME * alfordb	DESIGNED -	REVISED -	STATE OF ILLINOIS DEPARTMENT OF TRANSPORTATION	PROPOSED TYPICAL SECTIONS		SCALE:	SECTION	COUNTY	TOTAL SHEET
al:\pe\work\p\ridot\alfordb\08175876\0876184\sh-t-plan.dgn	PLOT SCALE * 100.0000' / IN.	DRAWN -	REVISED -				9/28	28RS-6	MADISON	33
	PLOT DATE * 3/17/2010	CHECKED -	REVISED -		SCALE: NONE	SHEET NO. OF SHEETS	STA. TO STA.	FED. ROAD DIST. NO.	(ILLINOIS) FED. AID PROJECT	CONTRACT NO. 76084
		DATE -	REVISED -							