

STATE OF ILLINOIS
DEPARTMENT OF TRANSPORTATION

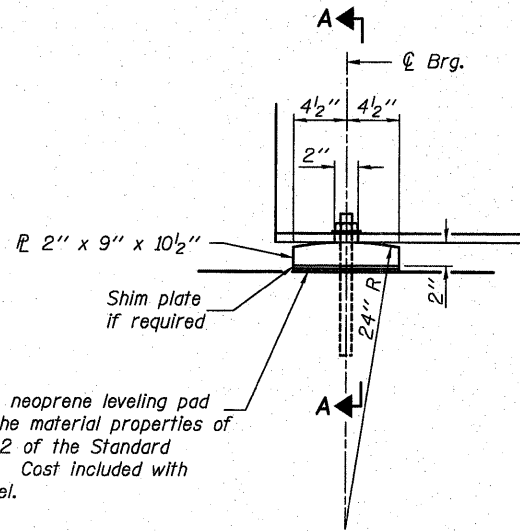

ELEVATION AT ABUTMENT

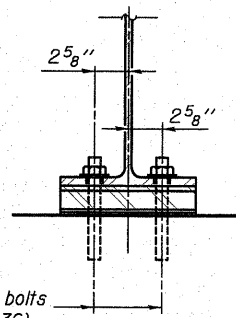

SECTION A-A

1/8" elastomeric neoprene leveling pad according to the material properties of Article 1052.02 of the Standard Specifications. Cost included with Structural Steel.

1" diameter x 12" anchor bolts (ASTM F1554 Grade 36) with 2 1/4" x 2 1/4" x 5/16" washer under nut. 1 1/2" x 2" slotted hole in flange. 1 1/2" diameter holes in bearing plate.

FIXED BEARING

TOP OF BEAM ELEVATIONS

(For Fabrication Only)

Beam No.	℄ Brg. S. Abut.	℄ Brg. N. Abut.
1	443.547	443.410
2	443.657	443.519
3	443.750	443.613
4	443.750	443.613
5	443.657	443.519
6	443.547	443.410

Notes:

Anchor bolts shall be ASTM F1554 all-thread (or an Engineer-approved alternate material) of the grade(s) and diameter(s) specified. ASTM A307 Grade C anchor bolts may be used in lieu of ASTM F1554 Grade 36 (Fy=36ksi). The corresponding specified grade of AASHTO M314 anchor bolts may be used in lieu of ASTM F1554.

Anchor bolts at fixed bearings may be either cast in place or installed in holes drilled after the supported member is in place.

Drilled and set anchor bolts shall be installed according to Article 521.06 of the Standard Specifications.

All bearing plates shall conform to the requirements of AASHTO M 270, Grade 50.

INTERIOR GIRDER MOMENT TABLE		
0.5 Span		
I_s	(in ⁴)	4,470
$I_c(n)$	(in ⁴)	12,384
$I_c(3n)$	(in ⁴)	9,139
S_s	(in ³)	300
$S_c(n)$	(in ³)	450
$S_c(3n)$	(in ³)	406
DC1	(k/')	0.74
M _{DC1}	(k)	254
DC2	(k/')	0.15
M _{DC2}	(k)	52
DW	(k/')	0.27
M _{DW}	(k)	92
M _{℄ + IM}	(k)	637
M _u (Strength I)	(k)	1,635
φ _r M _n	(k)	2,350
f _s DC1	(ksi)	10.2
f _s DC2	(ksi)	1.5
f _s DW	(ksi)	2.7
f _s 1.3(℄+IM)	(ksi)	22.1
f _s (Service II)	(ksi)	36.5
f _s (Total)(Strength I)	(ksi)	48.4
V _r	(k)	20.2

I_s, S_s : Non-composite moment of inertia and section modulus of the steel section used for computing f_s (Total-Strength I, and Service II) due to non-composite dead loads (in⁴ and in³).

$I_c(n), S_c(n)$: Composite moment of inertia and section modulus of the steel and deck based upon the modular ratio, "n", used for computing f_s (Total-Strength I, and Service II) due to short-term composite live loads (in⁴ and in³).

$I_c(3n), S_c(3n)$: Composite moment of inertia and section modulus of the steel and deck based upon 3 times the modular ratio, "3n", used for computing f_s (Total-Strength I, and Service II) due to long-term composite (superimposed) dead loads (in⁴ and in³).

DC1: Un-factored non-composite dead load (kips/ft.).
M_{DC1}: Un-factored moment due to non-composite dead load (kip-ft.).
DC2: Un-factored long-term composite (superimposed excluding future wearing surface) dead load (kips/ft.).
M_{DC2}: Un-factored moment due to long-term composite (superimposed excluding future wearing surface) dead load (kip-ft.).
DW: Un-factored long-term composite (superimposed future wearing surface only) dead load (kips/ft.).
M_{DW}: Un-factored moment due to long-term composite (superimposed future wearing surface only) dead load (kip-ft.).
M_{℄ + IM}: Un-factored live load moment plus dynamic load allowance (kip-ft.).
M_u (Strength I): Factored design moment (kip-ft.).
1.25 (M_{DC1} + M_{DC2}) + 1.5 M_{DW} + 1.75 M_{℄ + IM}
φ_rM_n: Compact composite positive moment capacity computed according to Article 6.10.7.1 (kip-ft.).
f_s (Service II): Sum of stresses as computed from the moments below (ksi).
M_{DC1} + M_{DC2} + M_{DW} + 1.3 M_{℄ + IM}
f_s (Total)(Strength I): Sum of stresses as computed from the moments below on non-compact section (ksi).
1.25 (M_{DC1} + M_{DC2}) + 1.5 M_{DW} + 1.75 M_{℄ + IM}
V_r: Maximum factored shear range in composite portion of span computed according to Article 6.10.10.

BILL OF MATERIAL

Item	Unit	Total
Anchor Bolts, 1"	Each	24

INTERIOR GIRDER REACTION TABLE		
HL93 Loading		
Abutment		
R _{DC1}	(k)	19.3
R _{DC2}	(k)	3.9
R _{DW}	(k)	7.0
R _{℄ + IM}	(k)	64.1
R _{Total}	(k)	94.3

DESIGNED	B.G.H.
CHECKED	L.D.G.
DRAWN	K.H.L.
CHECKED	B.G.H.

STEEL DETAILS

SHEET NO. 16	F.A.S. RTE.	SECTION	COUNTY	TOTAL SHEETS	SHEET NO.
	739	1-2BR	GREENE	150	98
21 SHEETS	S.N. 031-0040		CONTRACT NO. 76410		
FED. ROAD DIST. NO. _ ILLINOIS FED. AID PROJECT					