

NOTES:

1. SEE STANDARD C1 FOR DETAILS OF GUARDRAIL NOT SHOWN.
2. THRIE BEAM RAIL SHALL BE BOLTED TO BLOCK-OUT AT ALL POSTS.
3. ALL SLOPE RATIOS ARE EXPRESSED AS UNITS OF VERTICAL DISPLACEMENT TO UNITS OF HORIZONTAL DISPLACEMENT (V:H).
4. THE TYPE T6 TERMINAL IS TYPICALLY UTILIZED TO ATTACH GALVANIZED STEEL PLATE BEAM GUARDRAIL AT THE UPSTREAM END OF THE BRIDGES CONCRETE PARAPET, WHERE A ROADSIDE GUTTER IS TO BE INSTALLED.
5. SEE STANDARD B3 FOR GUTTER TRANSITION AT TRAFFIC BARRIER TERMINAL TYPE T6.
6. UNDER NO CIRCUMSTANCES SHALL AN EXISTING TERMINAL, THAT WAS DESIGNED USING A PREVIOUS STANDARD, BE ATTACHED TO OR MODIFIED IN ANYWAY FROM ITS ORIGINAL DESIGN. IF ANY MODIFICATION IS REQUIRED AND A PROPER WARRANT HAS BEEN COMPLETED, THE ENTIRE BARRIER INSTALLATION SHALL BE COMPLETELY REMOVED AND REPLACED WITH A NEW SYSTEM THAT COMFORMS TO THE CURRENT STANDARD.
7. TRAFFIC BARRIER TERMINAL SHALL BE IN ACCORDANCE WITH THE MANUFACTURER'S DETAILS AND SPECIFICATIONS.
8. TERMINAL POSTS SHALL NOT BE INSTALLED IN CONCRETE OR HMA PAVEMENTS. WHEN NECESSARY USE LEAVE-OUT DETAIL PER STANDARD C1, SHEET 4 OF 4.
9. TERMINAL POSTS TO BE INSTALLED PERPENDICULAR TO BACK OF GUTTER.
10. THE TERMINAL SYSTEM HAS BEEN PERFORMANCE-TESTED FOR CASHWORTHINESS UNDER PROCEDURES DEFINED IN THE NATIONAL COOPERATIVE HIGHWAY RESEARCH PROGRAM (NCHRP) REPORT 350. NO MODIFICATION TO THIS STANDARD DRAWING SHALL BE PERMITTED.

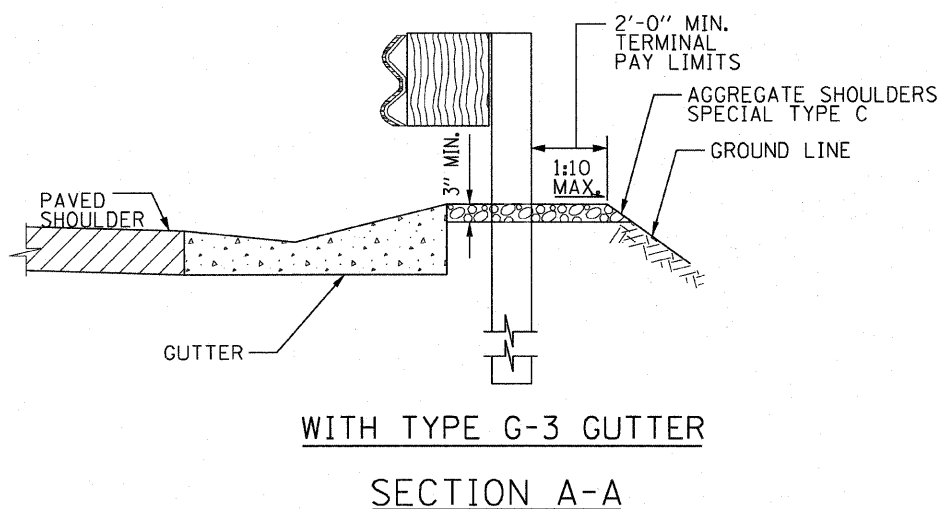

**FOR PARAPET (SAFETY FACE)
WITH TYPE G-3 GUTTER**



REVISIONS	
3-1-2010	ADDED SECTION A-A DETAIL, REVISED STEEL POSTS, REVISED NOTES

TRAFFIC BARRIER
TERMINAL, TYPE T6

STANDARD C9-01

APPROVED: *Paul Kovacs* CHIEF ENGINEER DATE 7-1-2009