

F.A.P. RTE.	SECTION	COUNTY	TOTAL SHEETS	SHEET NO.
55	100 (I&2) I-9	WILL	59	6
STA.		TO STA.		
FED. ROAD DIST. NO.	ILLINOIS	FED. AID PROJECT		
		TYP-02 OF 02		

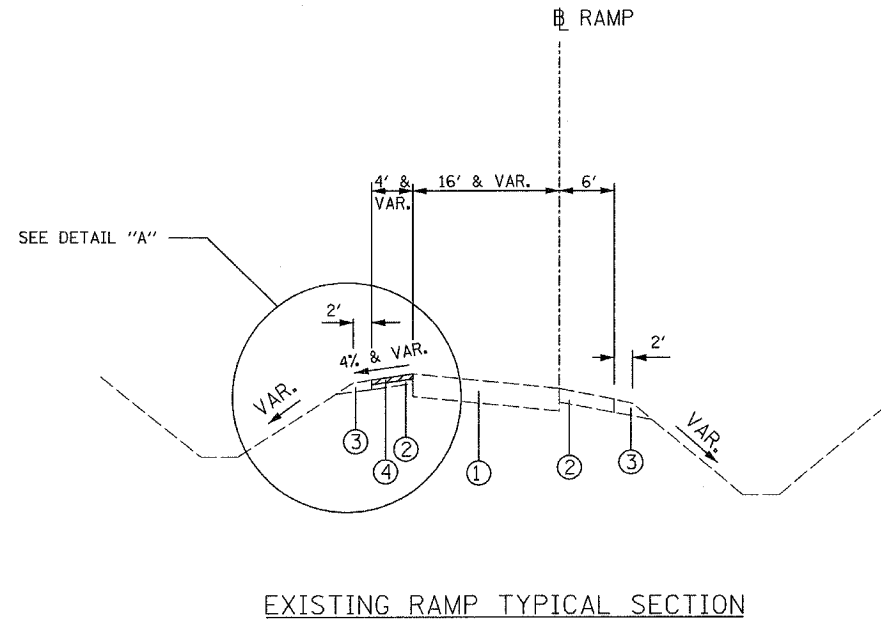
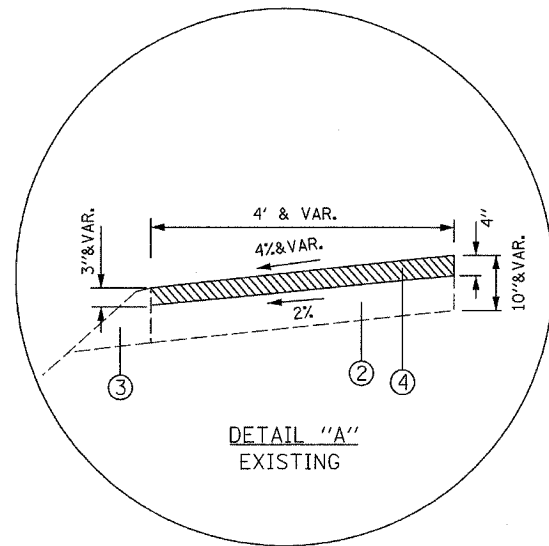

EXISTING LEGEND

- ① P.C.C. PAVEMENT
- ② BITUMINOUS SHOULDER
- ③ AGGREGATE SHOULDER
- ④ BITUMINOUS SURFACE REMOVAL, (VARIABLE DEPTH)

PROPOSED LEGEND

- Ⓐ BITUMINOUS BASE COURSE, 4"
- Ⓑ AGGREGATE SHOULDERS, TYPE B (SPECIAL)
- Ⓒ CLASS D PATCHES, 6" (SEE NOTE 1)

NOTES:

1. CLASS D PATCHES SHALL BE AT LOCATIONS AS DIRECTED BY THE ENGINEER. THE DEPTH OF THE PATCH SHALL BE MEASURED AT THE INSIDE EDGE OF THE SHOULDER ADJACENT TO THE MAINLINE PAVEMENT AND SHALL NOT INCLUDE THE DEPTH OF THE BITUMINOUS SURFACE REMOVAL, (VARIABLE DEPTH).

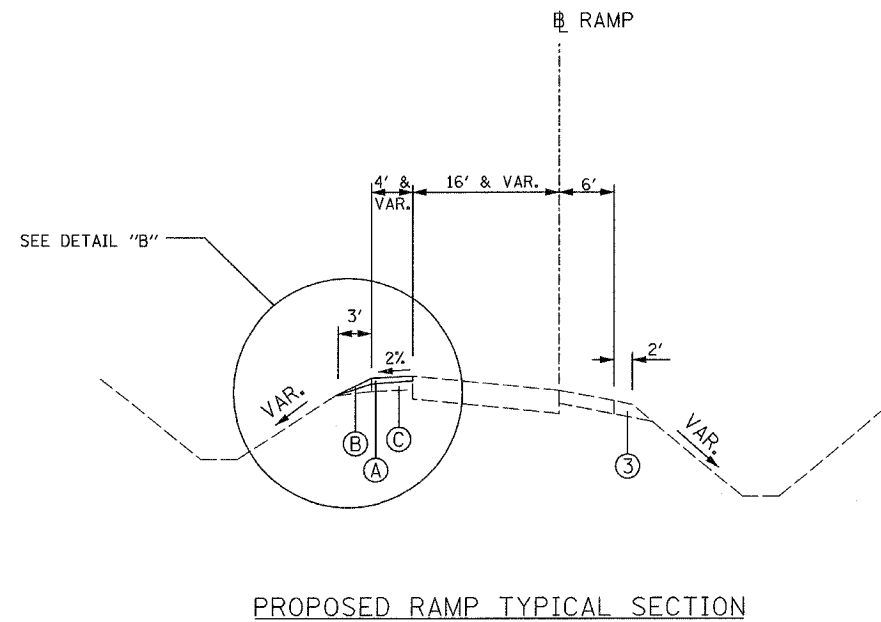
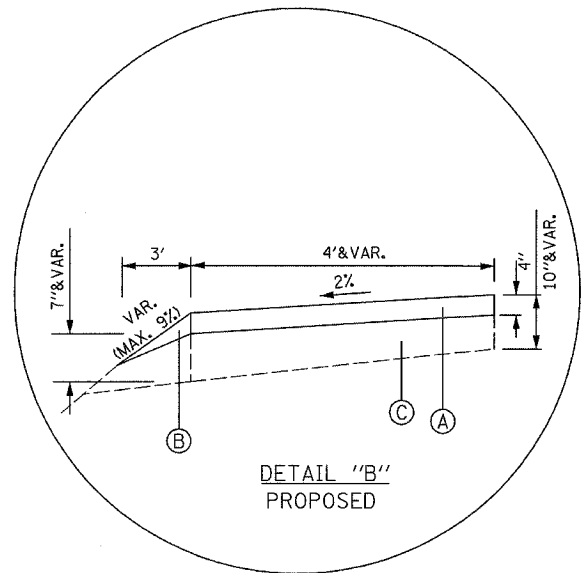

REVISIONS	
NAME	DATE

ILLINOIS DEPARTMENT OF TRANSPORTATION
 FAI ROUTE 55
 US RTE. 30 TO WEBER ROAD
 TYPICAL SECTIONS



SCALE: NONE
 DATE: 03-15-06

DRAWN BY: DM
 CHECKED BY: DVS

FINAL