

FIBER OPTIC UTILITY MARKER (UM)

WARNING PLATE (WP)

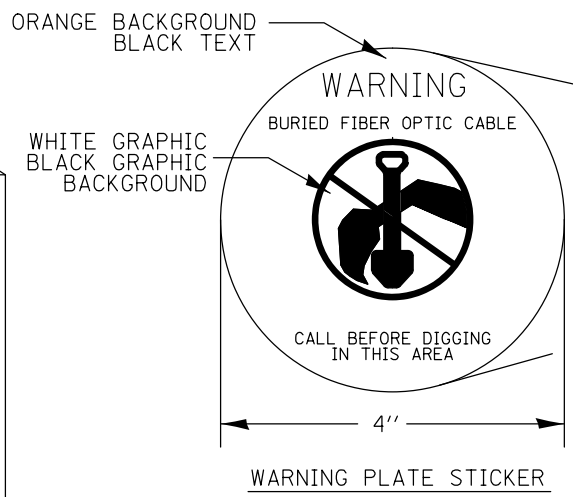

FIBER OPTIC UTILITY MARKER STICKER (UMS)
 THE UMS WILL BE 2-7/8" X 14" WITH AN ORANGE BACKGROUND WITH BLACK TEXT.
 THE "WARNING" TEXT WILL BE WHITE ON A BLACK BAND

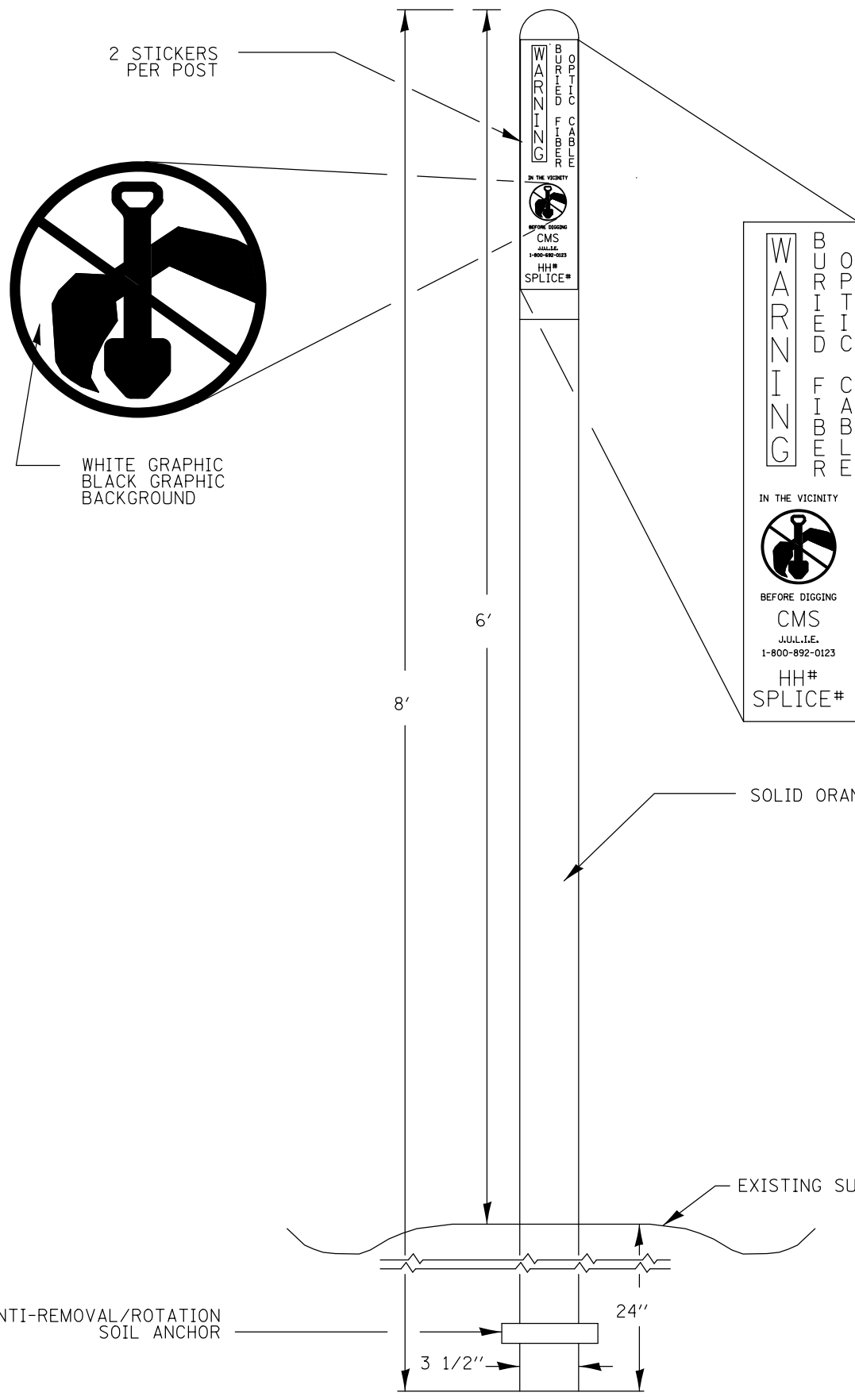
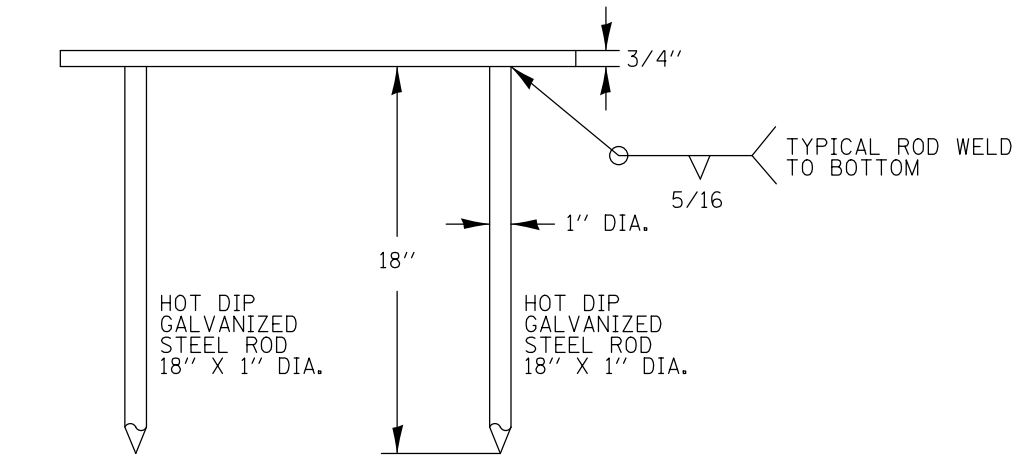
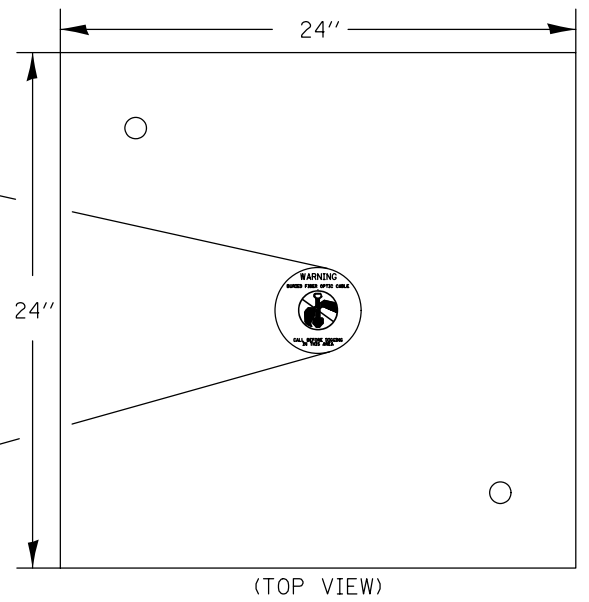

(ELEVATION VIEW)
 NOTE: ALL STEEL SHALL BE A-36 MILD STEEL AND GALVANIZED ACCORDING TO ASTM 123 AFTER RODS ARE WELDED TO THE PLATE

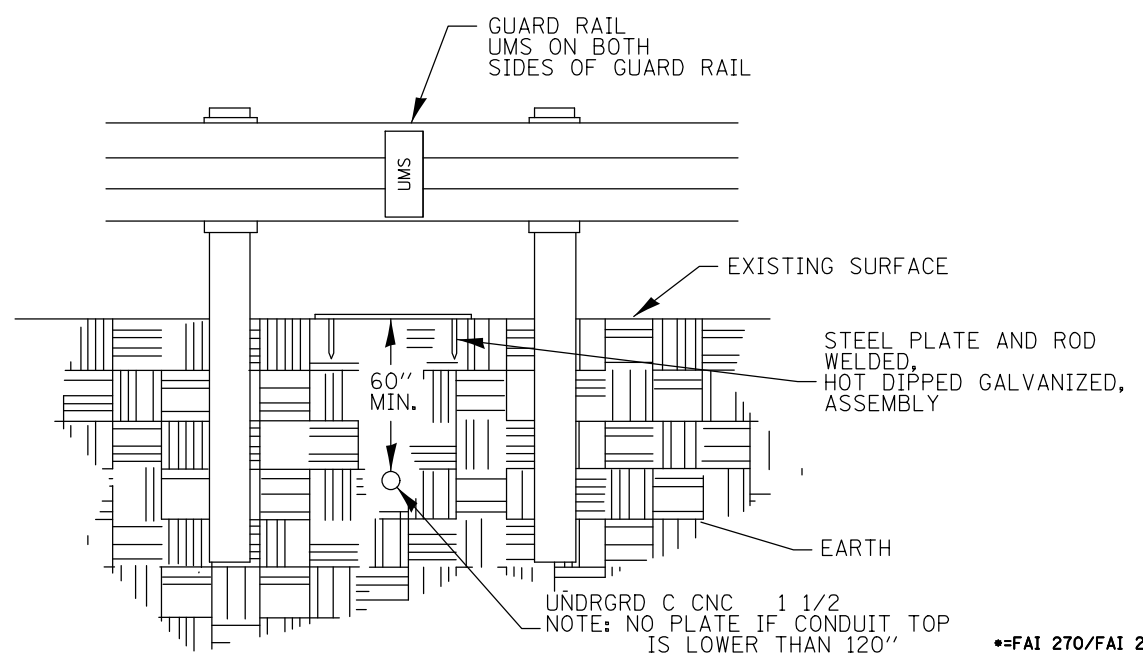

FILE NAME =	USER NAME = prestonme	DESIGNED -	REVISED -
et:\pw\work\p\dot\prestonme\d0298000\d076f77-sht-ITS.dgn		DRAWN -	REVISED -
	PLOT SCALE = 100.0000' / 1in.	CHECKED -	REVISED -
	PLOT DATE = 3/21/2013	DATE -	REVISED -

**STATE OF ILLINOIS
 DEPARTMENT OF TRANSPORTATION**

WARNING SIGN, PLATE AND STICKER DETAILS			
SCALE:	SHEET NO.	OF SHEETS	STA. TO STA.

*FAI 270/FAI 255/FAI 55/70			
F.A.I. RTE.	SECTION	COUNTY	TOTAL SHEETS
	DIST 8 ITS 2013-1	MADISON	27
			SHEET NO. 6
CONTRACT NO. 76F77			
FED. ROAD DIST. NO. ILLINOIS FED. AID PROJECT			