

TOP PLAN

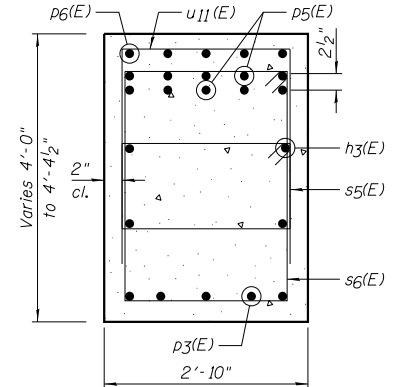

SECTION A-A

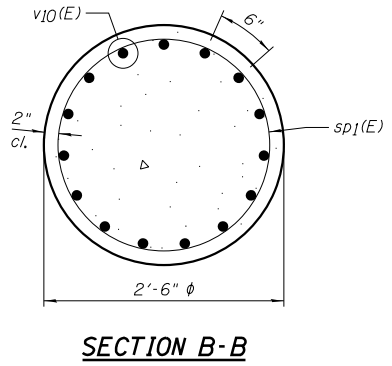

SECTION B-B

Location	Bar	Bar Quantity
A	u6(E)	8
B	u7(E)	8
C	u8(E)	6
D	u9(E)	6
E	u10(E)	4

NOTE: Quantity is for each end.

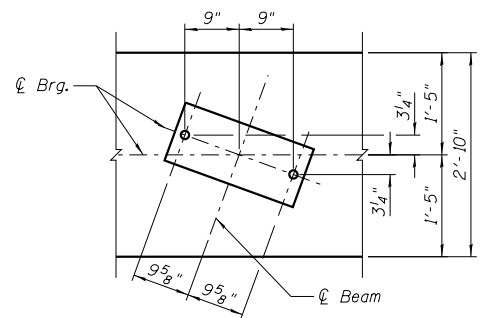

TYPICAL ANCHOR BOLT PLACEMENT DETAIL

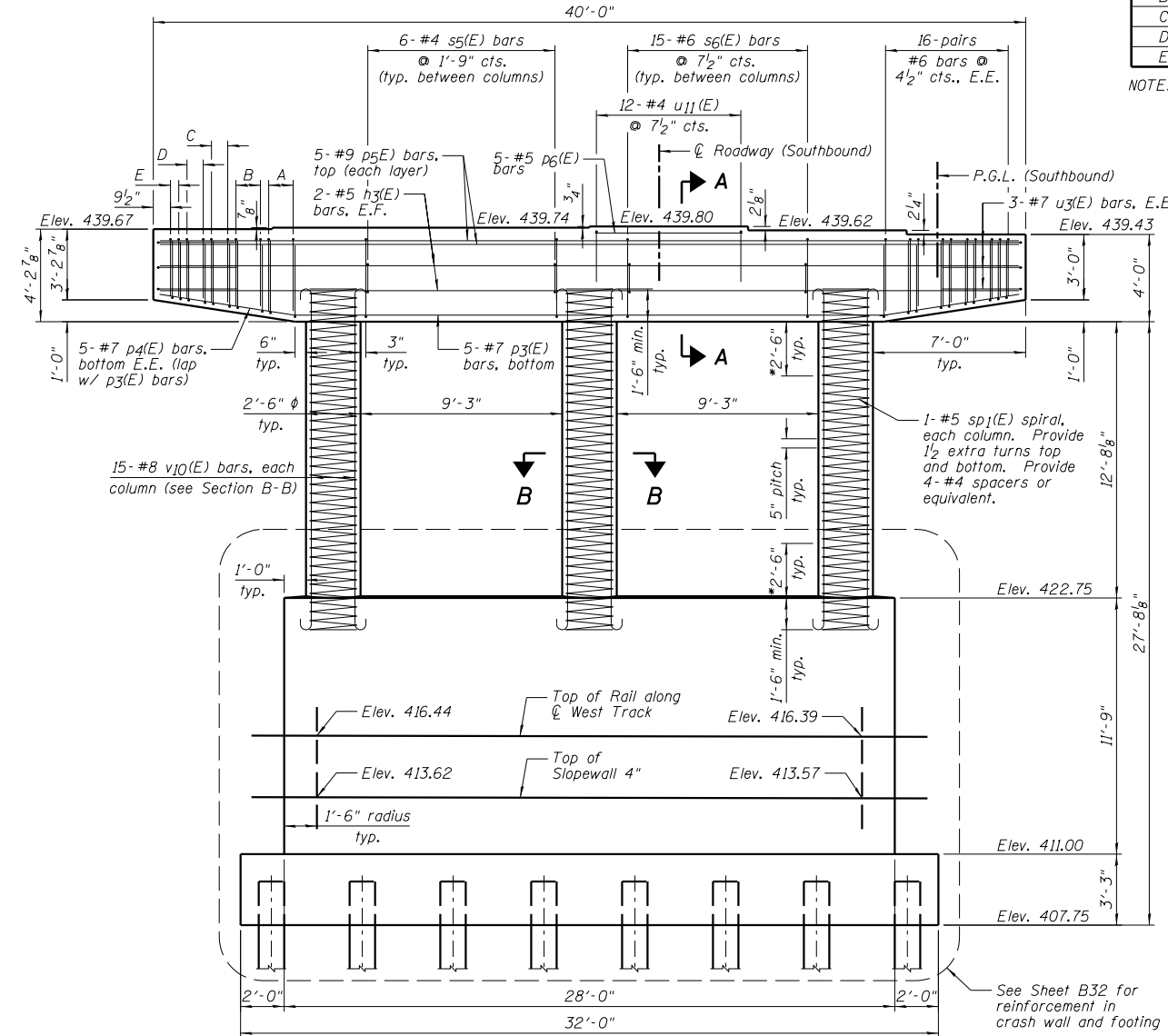

ELEVATION
(Looking North)

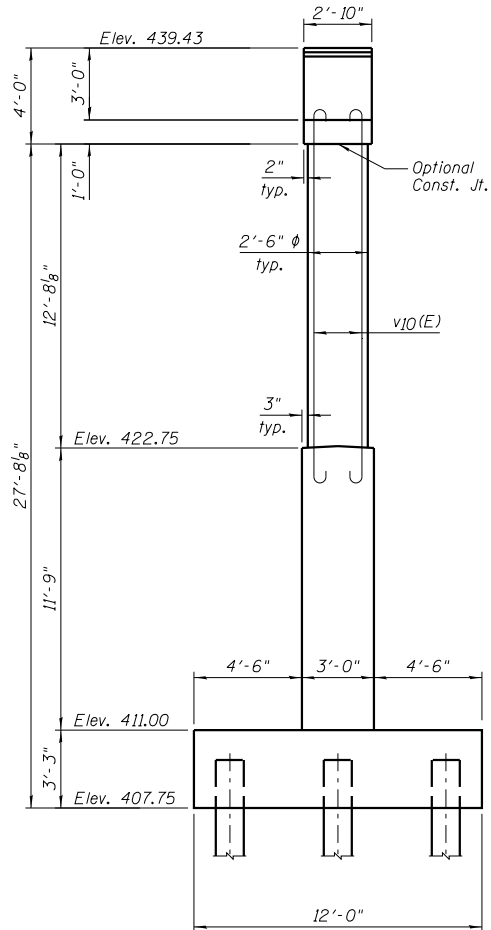

END VIEW

PIER NO. 2 BILL OF MATERIAL

Bar	No.	Size	Length	Shape
h2(E)	18	#6	25'-0"	—
h3(E)	4	#5	36'-10"	—
h4(E)	14	#6	17'-4"	—
n(E)	56	#8	7'-11"	U
n1(E)	52	#8	9'-11"	U
p3(E)	5	#7	26'-8"	—
p4(E)	10	#7	11'-7"	—
p5(E)	10	#9	36'-10"	—
p6(E)	5	#5	6'-11"	—
s4(E)	255	#4	3'-9"	U
s5(E)	12	#4	8'-1"	U
s6(E)	30	#6	13'-8"	U
sp1(E)	3	#5	16'-0"	W
t1(E)	51	#7	11'-6"	—
t2(E)	33	#6	13'-10"	U
u2(E)	14	#6	11'-10"	U
u3(E)	6	#7	14'-1"	U
u4(E)	26	#8	13'-10"	U
u5(E)	25	#8	17'-10"	U
u6(E)	16	#6	9'-2"	U
u7(E)	16	#6	8'-10"	U
u8(E)	12	#6	8'-6"	U
u9(E)	12	#6	8'-2"	U
u10(E)	8	#6	7'-8"	U
u11(E)	12	#4	7'-0"	U
u12(E)	18	#6	13'-10"	U
v8(E)	6	#8	7'-7"	—
v10(E)	45	#8	17'-10"	U
w1(E)	30	#6	31'-6"	—

Item	Unit	Quantity
Structure Excavation	Cu. Yd.	129
Concrete Structures	Cu. Yd.	105.7
Reinforcement Bars, Epoxy Coated	Pound	17,140
Mechanical Splicers	Each	136
Furnishing Metal Shell Piles 14" x 0.312"	Foot	943
Driving Piles	Foot	943
Test Pile Metal Shells	Each	1

** Length is height of spiral.

PILE DATA

Pile Type and Size	Metal Shell - 14 in. dia. x 0.312 in. walls
Nominal Required Bearing	437 kips
Factored Resistance Available	240 kips
Estimated Pile Length	41 Feet
Number of Production Piles	23
Number of Test Piles	1

NOTES:

- 1.) Space reinforcement in caps to miss anchor bolts.
- 2.) Pour steps monolithically with cap.
- 3.) E.F. denotes Each Face and E.E. denotes Each End.
- 4.) *Limits of plastic hinging region. Splicing of reinforcement will not be allowed in this region.
- 5.) See Sheet B32 for details of Crash Wall, Footing and Pile Layout.
- 6.) See Sheet B33 for Bar Bending Diagrams.



DESIGNED - TCR	REVISED
CHECKED - JML	REVISED
DRAWN - JWK/DJM	REVISED
CHECKED - MSW	REVISED

STATE OF ILLINOIS
DEPARTMENT OF TRANSPORTATION

PIER NO. 2, SOUTHBOUND
STRUCTURE NO. 082-0314 NB & 082-0315 SB

SHEET NO. B29 OF 50 SHEETS

F.A.P. RTE.	SECTION	COUNTY	TOTAL SHEETS	SHEET NO.
788	520-1-2HVB-1	ST. CLAIR	237	162

CONTRACT NO. 76848

ILLINOIS FED. AID PROJECT