

P:\CX31000\100cadd\1095tr\FINAL\_PLANS\0820334-76848-033-Girder\_Camber(NB).dgn  
 17-OCT-2012  
 16:29

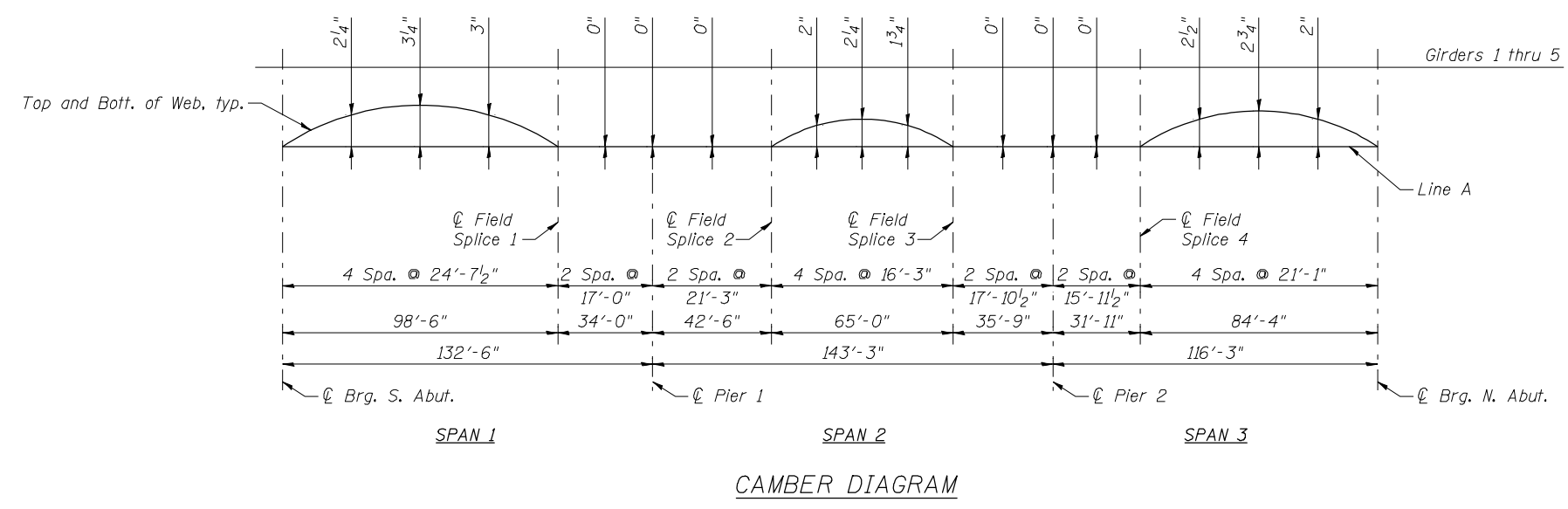

\* TOP OF GIRDER WEB ELEVATIONS

Location Girder	℄ Brg. South Abut.	℄ Field Splice 1	℄ Brg. and ℄ Pier 1	℄ Field Splice 2	℄ Field Splice 3	℄ Brg. and ℄ Pier 2	℄ Field Splice 4	℄ Brg. North Abut.
Girder 1	445.01	446.88	447.28	447.78	448.34	448.47	448.58	448.35
Girder 2	445.07	446.96	447.37	447.88	448.46	448.61	448.74	448.51
Girder 3	445.03	446.93	447.35	447.88	448.47	448.63	448.77	448.58
Girder 4	444.81	446.73	447.16	447.70	448.31	448.48	448.63	448.47
Girder 5	444.56	446.47	446.92	447.47	448.11	448.29	448.44	448.31

\* For fabrication only.

Notes:  
 Line A is a straight line at the top of web plates between ℄ bearing and ℄ field splice or from ℄ field splice to ℄ field splice.