

PLAN
(For skews $\leq 30^\circ$)

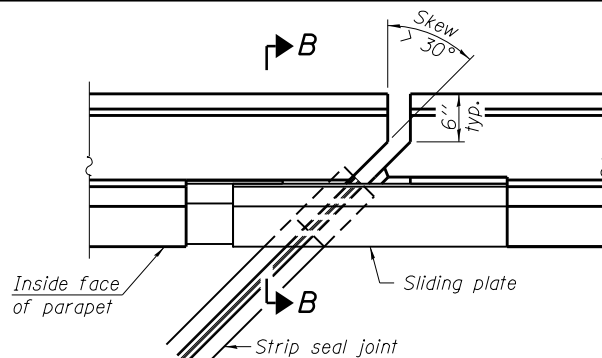

PLAN
(For skews $> 30^\circ$)
Showing point block

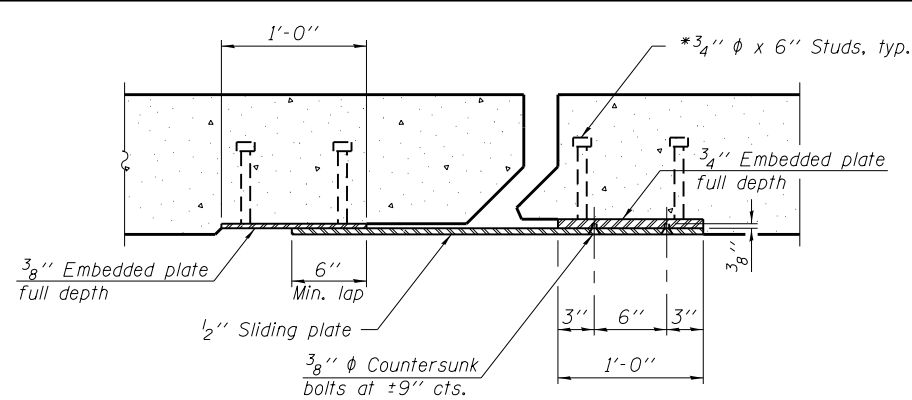

SECTION C-C

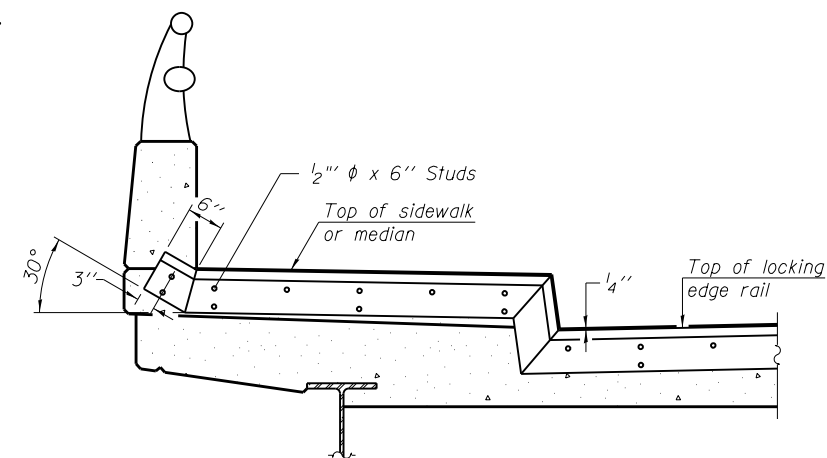

TYPICAL END TREATMENT AT SIDEWALK OR MEDIAN

Shorter plates with a single row of studs at 12" cts. may be necessary on medians which are shallower than 9". See manufacturer's recommendation.

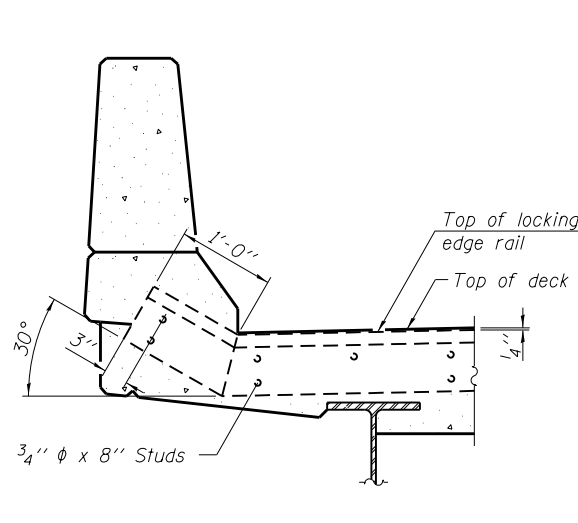

SECTION A-A

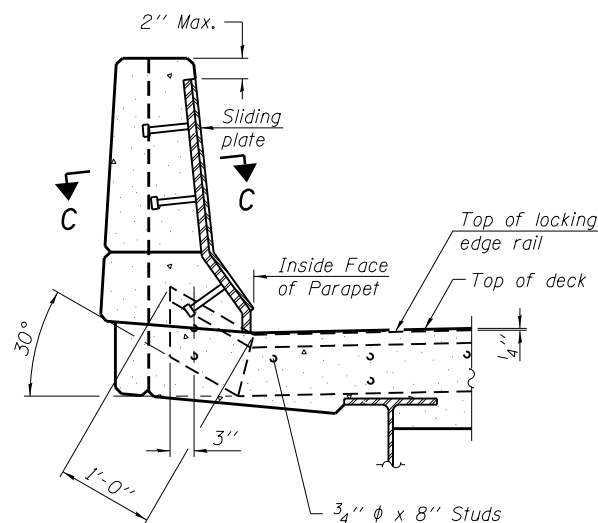

SECTION B-B

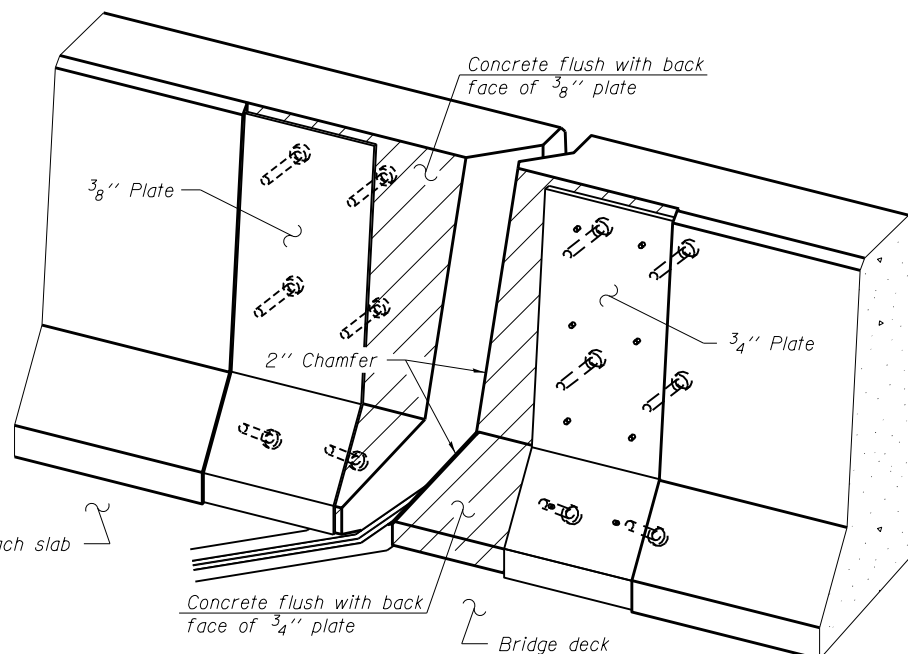

TRIMETRIC VIEW
(Showing back plates only)

Notes:

The strip seal shall be made continuous and shall have a minimum thickness of 1/4". The configuration of the strip seal shall match the configuration of the Locking Edge Rails. Open or "webbed" strip seal gland configurations are not permitted. The gland shall be sized for a maximum rated movement of 4 inches.

The height and thickness of the Locking Edge Rails shown are minimum dimensions. The actual configuration of the Locking Edge Rails and matching strip seal may vary from manufacturer to manufacturer. Flanged edge rails will not be allowed.

The inside of the Locking Edge Rail groove shall be free of weld residue.

Locking Edge Rails may be spliced at slope discontinuities and stage construction joints.

The manufacturer's recommended installation methods shall be followed.

All steel components shall be galvanized after fabrication according to Article 520.03 of the Standard Specifications.

Maximum space between rail segments at stage lines shall be 3#16", sealed with a suitable sealant.

Parapet plates and anchorage studs for skews > 30° included in the cost of Preformed Joint Strip Seal.

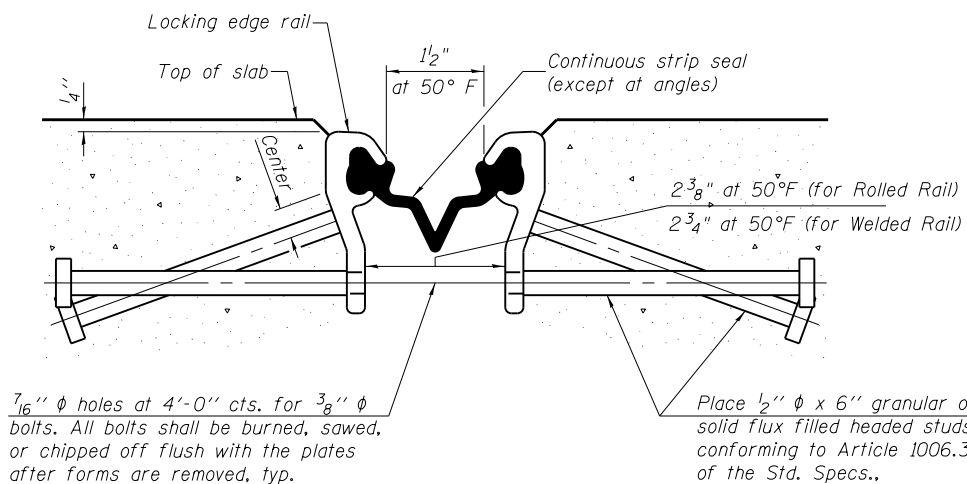

SECTION THRU STRIP SEAL JOINT FOR OVERLAY OVER DECK BEAMS

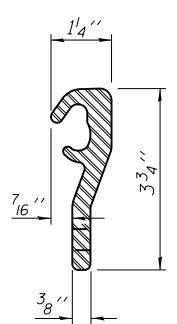

ROLLED (EXTRUDED) RAIL

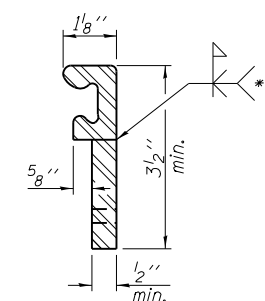

WELDED RAIL

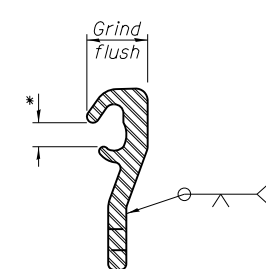

LOCKING EDGE RAIL SPLICE

Rolled rail shown, welded rail similar.

- * Omit weld at seal opening.
- ** Back gouge not required if complete joint penetration is verified by mock-up.

LOCKING EDGE RAIL

BILL OF MATERIAL

Item	Unit	Total
Preformed Joint Strip Seal	Foot	230.0

FILE NAME =	USER NAME = steffenmk	DESIGNED - DFZ	REVISED -
ei:\pw_work\p\idot\steffenmk\d0187065\074615-shit-brd\details.dgn		DRAWN - DFZ	REVISED -
Default	PLOT SCALE = 40.0000' / in.	CHECKED - MEA	REVISED -
	PLOT DATE = 3/28/2013	DATE - 10/31/2012	REVISED -

**STATE OF ILLINOIS
DEPARTMENT OF TRANSPORTATION**

**PREFORMED JOINT STRIP SEAL
SN. 087-0020**

SCALE: SHEET 16 OF 17 SHEETS STA. TO STA.

F.A.P. RTE.	SECTION	COUNTY	TOTAL SHEETS	SHEET NO.
325	(11B-11BR)	SHELBY	32	31
ILLINOIS FED. AID PROJECT			CONTRACT NO. 74615	