

EXISTING CONSTRUCTION

BRIDGE APPROACH PAVEMENT CONNECTOR (PCC)

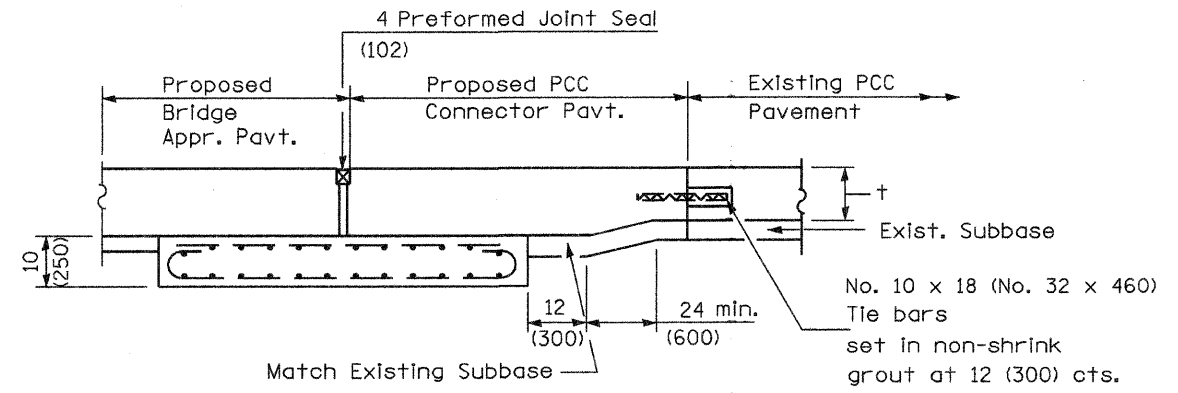

SECTION G-G - RIGID PAVEMENT

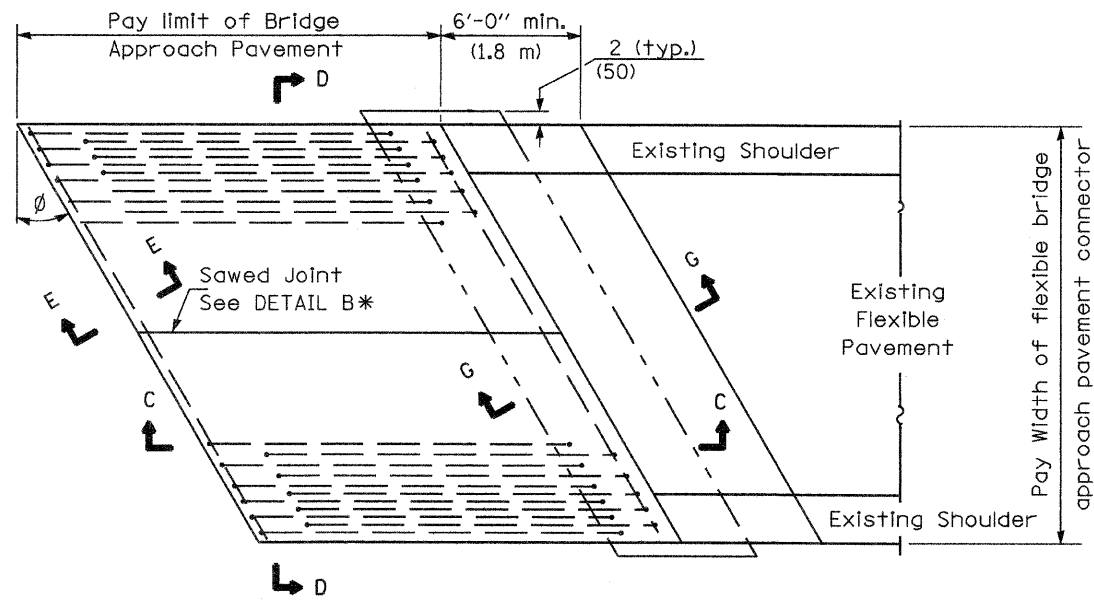

BRIDGE APPROACH PAVEMENT CONNECTOR (FLEXIBLE)

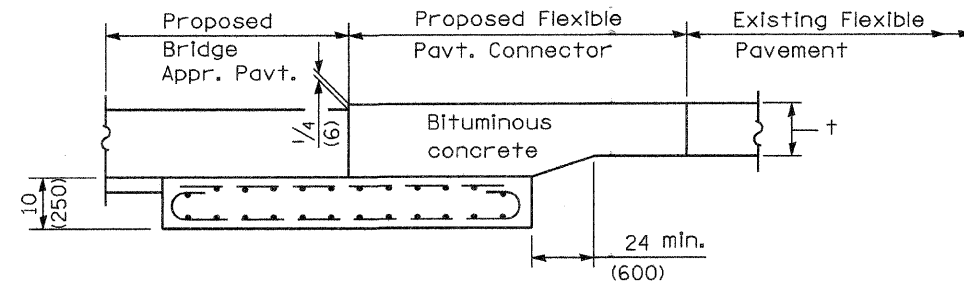

SECTION G-G - FLEXIBLE PAVEMENT

Illinois Department of Transportation
 APPROVED January 1, 2008
Ralph E. Anderson
 ENGINEER OF BRIDGES AND STRUCTURES
 APPROVED January 1, 2008
Ken C. Han
 ENGINEER OF DESIGN AND ENVIRONMENT
 ISSUED 1-1-97

BRIDGE APPROACH PAVEMENT

(Sheet 2 of 4)

FAI RTE.	SECTION	COUNTY	TOTAL SHEETS	SHEET NO.	CONTRACT #
74	(48-2646-4) I	KNOX	54	54B	88919

D.R.S. 1/14