

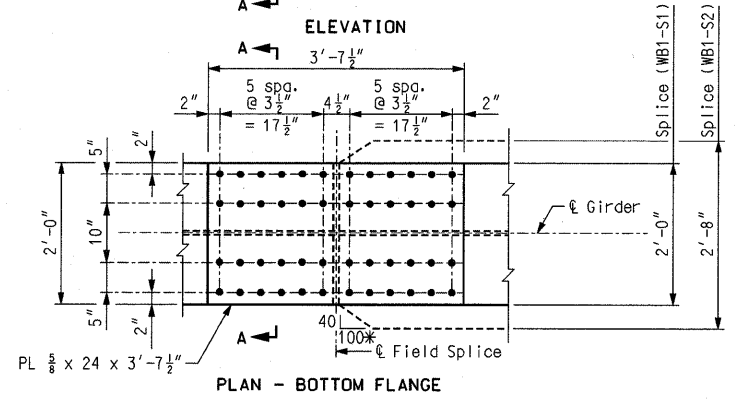

Splice	Top Flange			Bottom Flange		
	PL "A"	PL "B"	FILL PL "C"	PL "D"	PL "E"	FILL PL "F"
(WB1-S1)	7/8 x 20	1 1/8 x 20	1/4 x 20 x 18"	1 x 24	1 3/8 x 24	3/8 x 24 x 21 1/2"
(WB1-S2)	1 x 20	1 1/8 x 26	1/8 x 20 x 18"	1 3/8 x 24	1 3/8 x 32	-
(WB1-S3)	1 x 20	1 3/8 x 20	3/8 x 20 x 2'-1"	1 1/8 x 24	1 3/4 x 24	3/8 x 24 x 2'-8"
(WB1-S4)	1 x 20	1 3/8 x 20	3/8 x 20 x 2'-1"	1 3/8 x 24	1 3/4 x 24	3/8 x 24 x 2'-8"

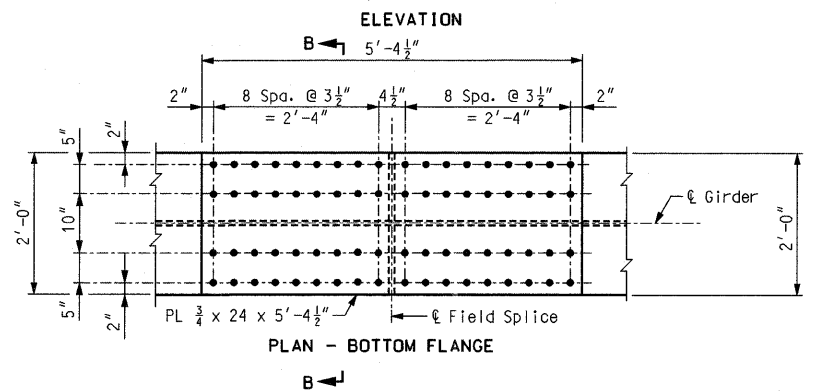
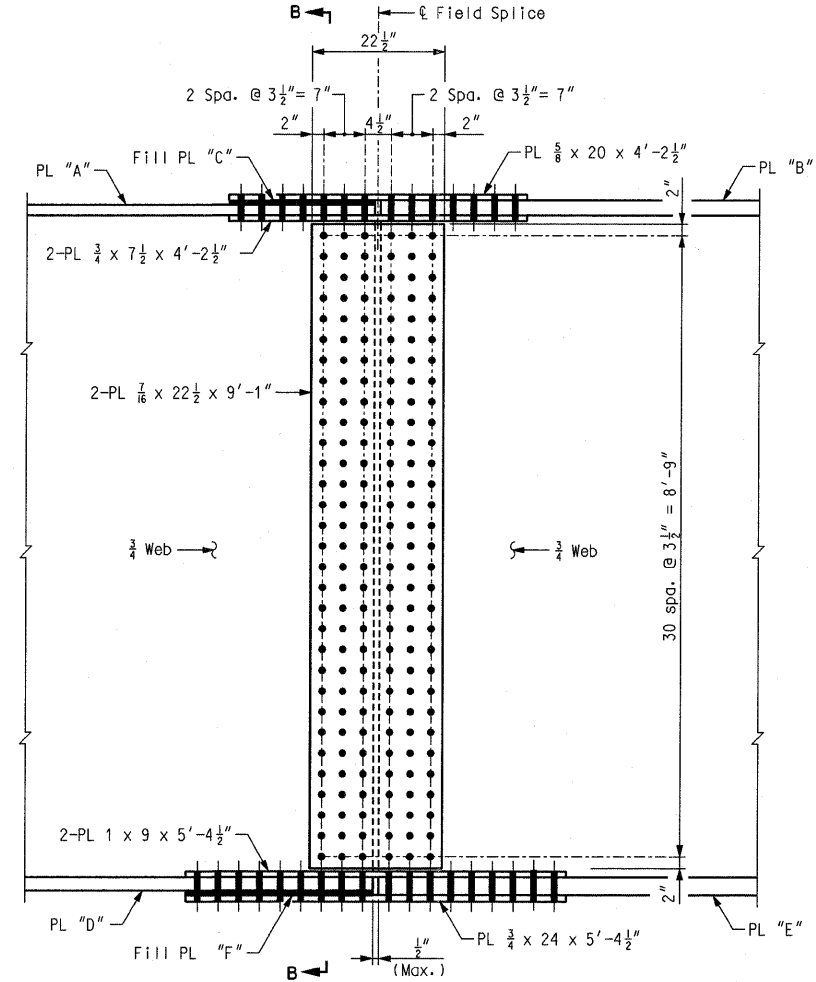
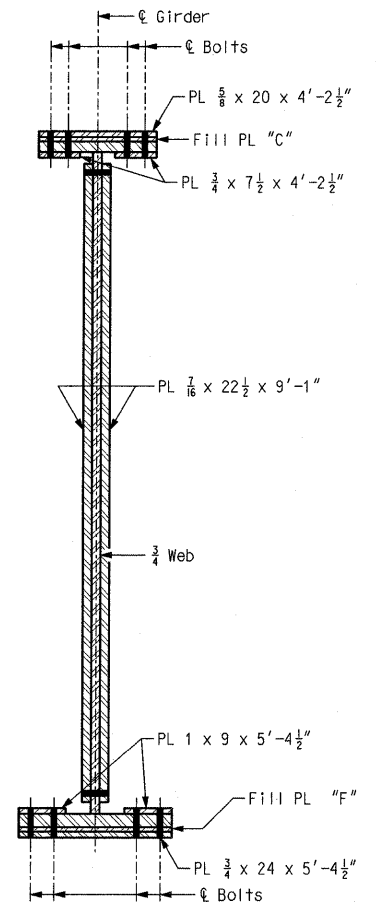
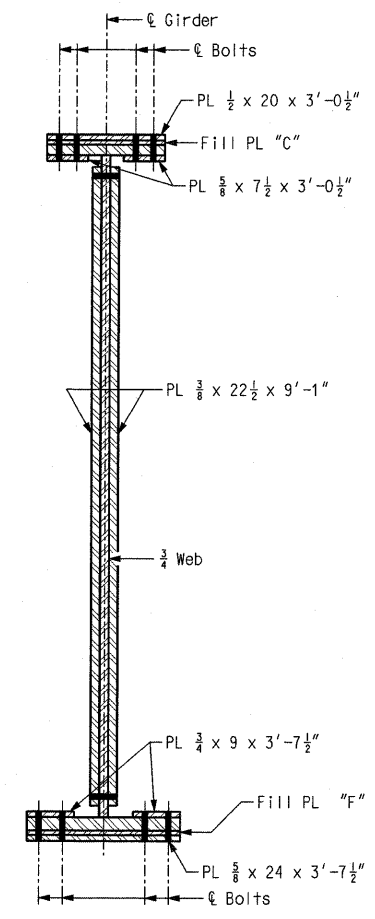
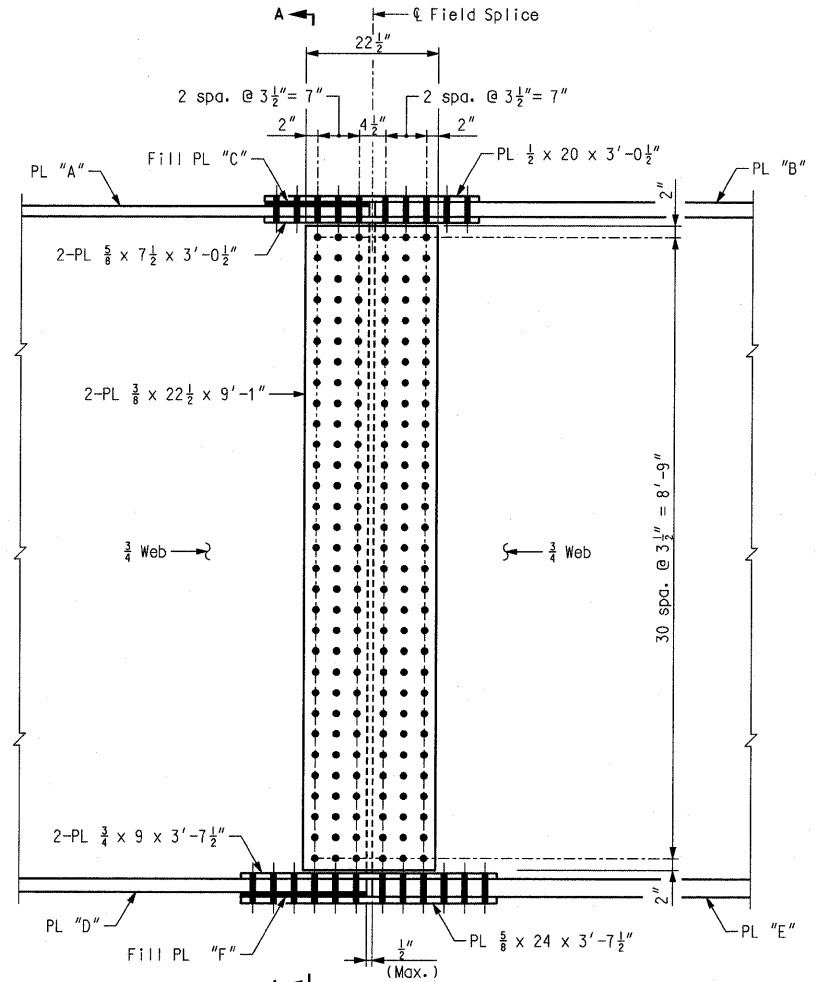
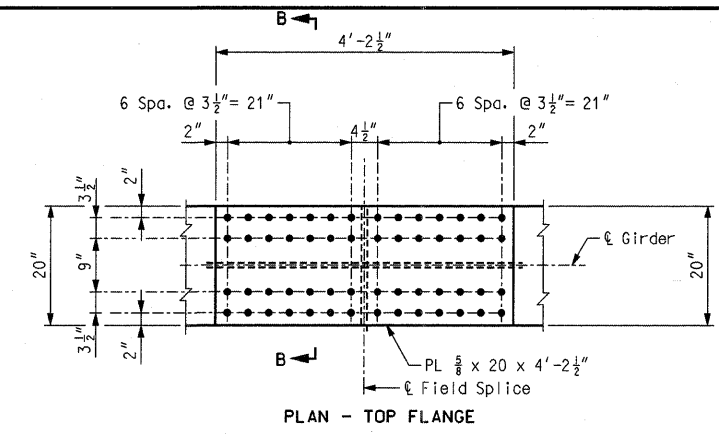
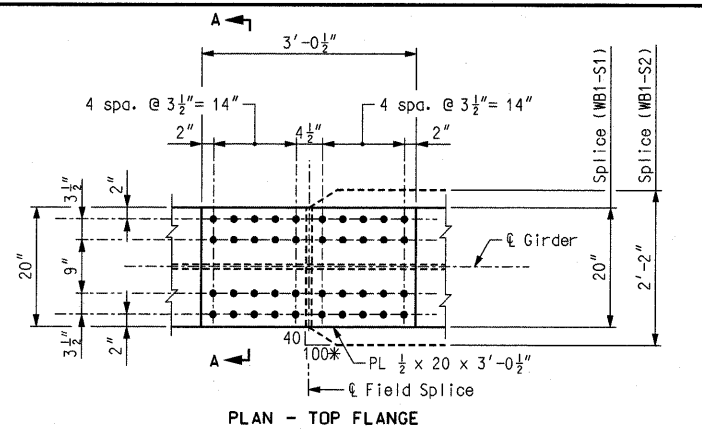

FIELD SPLICE (WB1-S1) & (WB1-S2)

FIELD SPLICE (WB1-S3) AND (WB1-S4)
BOLTED FIELD SPLICE DETAILS - WB UNIT 1

Notes:
Use 1" Ø A325 high strength bolts with 1 1/16" Ø holes.
Faying surfaces shall be in accordance with Sec.1080.4 for weathering steel and Sec. 1081 for surface preparation.
All splice plates except fill plates shall be subject to notch toughness requirements.
Fabricated structural steel for splice plates and fill plates shall be ASTM A709 Grade 50W.
For location of field splices, see Sheet Nos. 49 and 55.
* When width of flanges being spliced differs by more than 2", the larger flange shall be beveled as indicated.