

STATE OF ILLINOIS
DEPARTMENT OF TRANSPORTATION

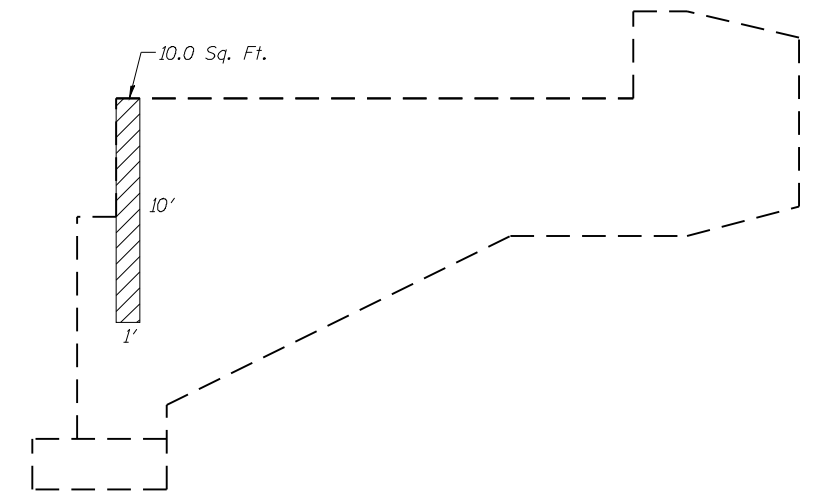

EAST ABUTMENT

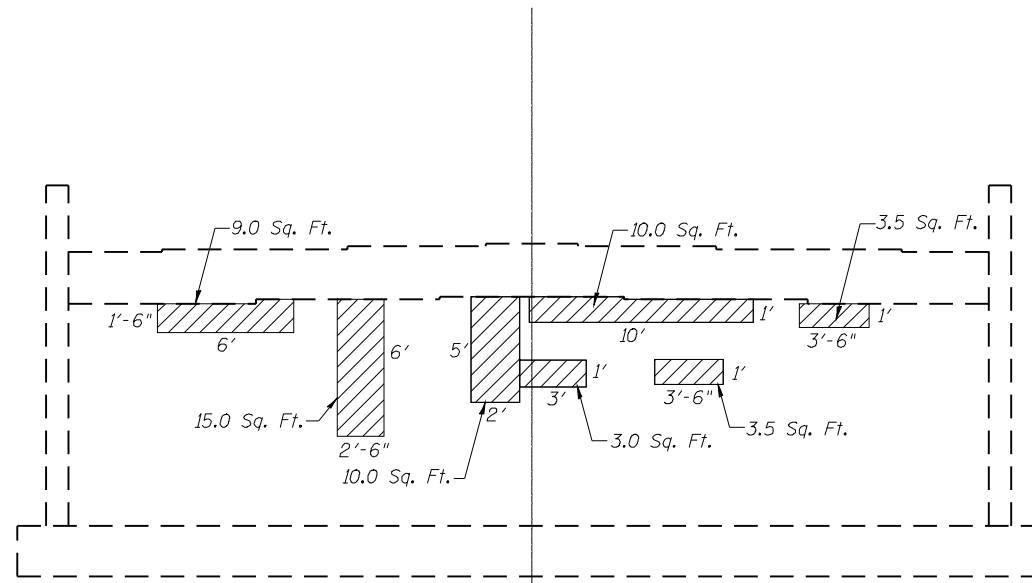
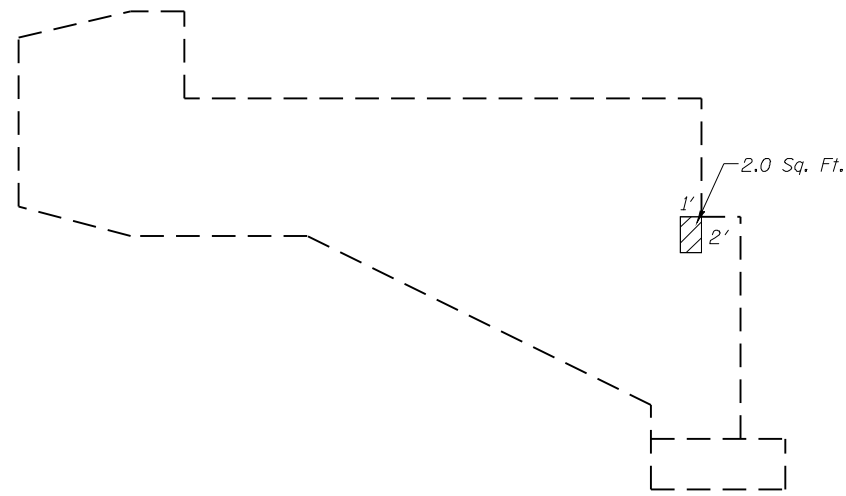
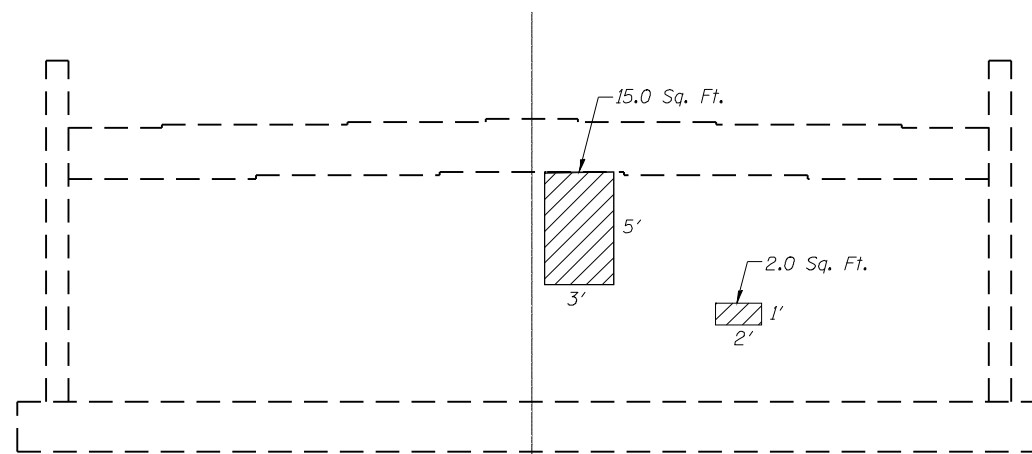
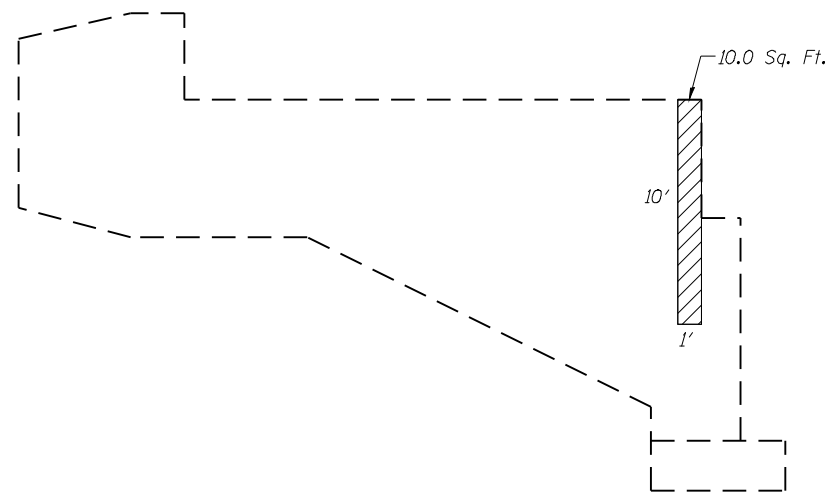

WEST ABUTMENT

Notes:
Quantities and repair areas shown are estimated, actual quantities to be determined by the Resident Engineer.
Concrete Sealer to be applied to exposed vertical faces and beam seats of the abutments.
The concrete sealer shall be a pigmented epoxy sealer from the department's approved product list for concrete sealers. It shall be applied in two coats. The color shall be per Federal Standard 595B Grey #36622."

Structural Repair of Concrete \leq 5"

BILL OF MATERIAL

Item	Unit	Total
Structural Repair of Concrete Depth equal to or less than 5 inches	Sq. Ft.	93
Concrete Sealer	Sq. Ft.	2260

**ABUTMENT PATCHING PLAN
STRUCTURE NO. 059-0044**

SHEET NO. 8 10 SHEETS	F.A.I. RTE.	SECTION	COUNTY	TOTAL SHEETS	SHEET NO.
	55	59RS-2, BR	Macoupin	100	88
CONTRACT NO. 72A60					
FED. ROAD DIST. NO.		ILLINOIS	FED. AID PROJECT		