

# DETAILS FOR RAMP INTERSECTION RESURFACING TRANSITIONS & BUTT JOINTS

CONTRACT NO. 70022

F.A.I. RTE.	SECTION	COUNTY	TOTAL SHEETS	SHEET NO.
72	*	PIATT	251	188

\* (58,74-66)&(74-67&68)RS-1

## I-72 INTERCHANGE NO. 164 AT FAP 135 (BRIDGE STREET)

INTERSECTION OF FAP 135 WITH RAMP A & RAMP B

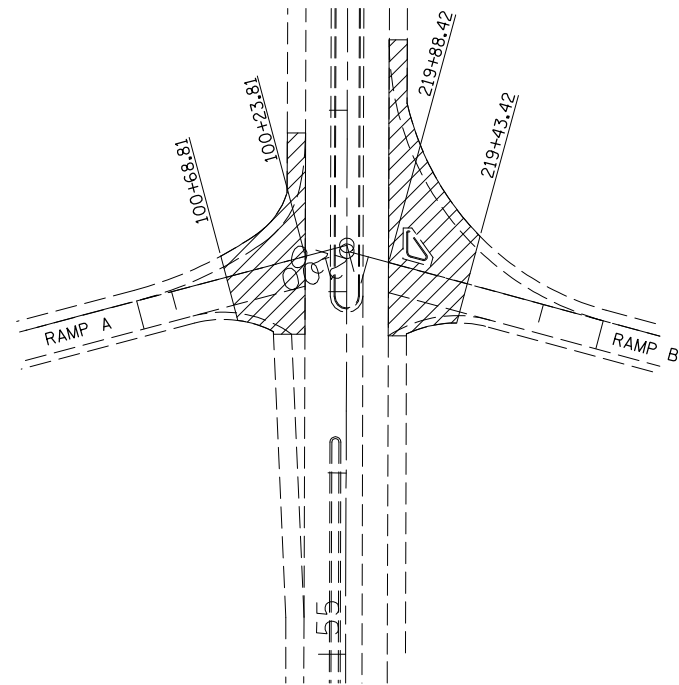

INTERSECTION OF FAP 135 WITH RAMP C & RAMP D

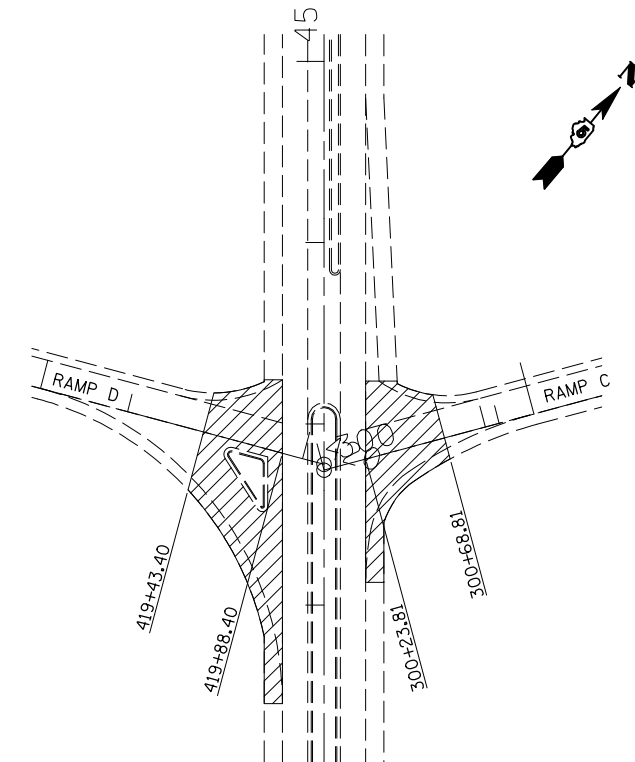

 HOT-MIX ASPHALT SURFACE REMOVAL - BUTT JOINT  
AREA INCLUDES BOTH RAMP LANE AND HMA SHOULDERS

NOT TO SCALE

## HOT-MIX ASPHALT SURFACE REMOVAL - BUTT JOINT

- RAMP A STATION 100+23.81 TO STATION 100+68.81
- RAMP B STATION 219+43.42 TO STATION 219+88.42
- RAMP C STATION 300+23.81 TO STATION 300+68.81
- RAMP D STATION 419+43.40 TO STATION 419+88.40

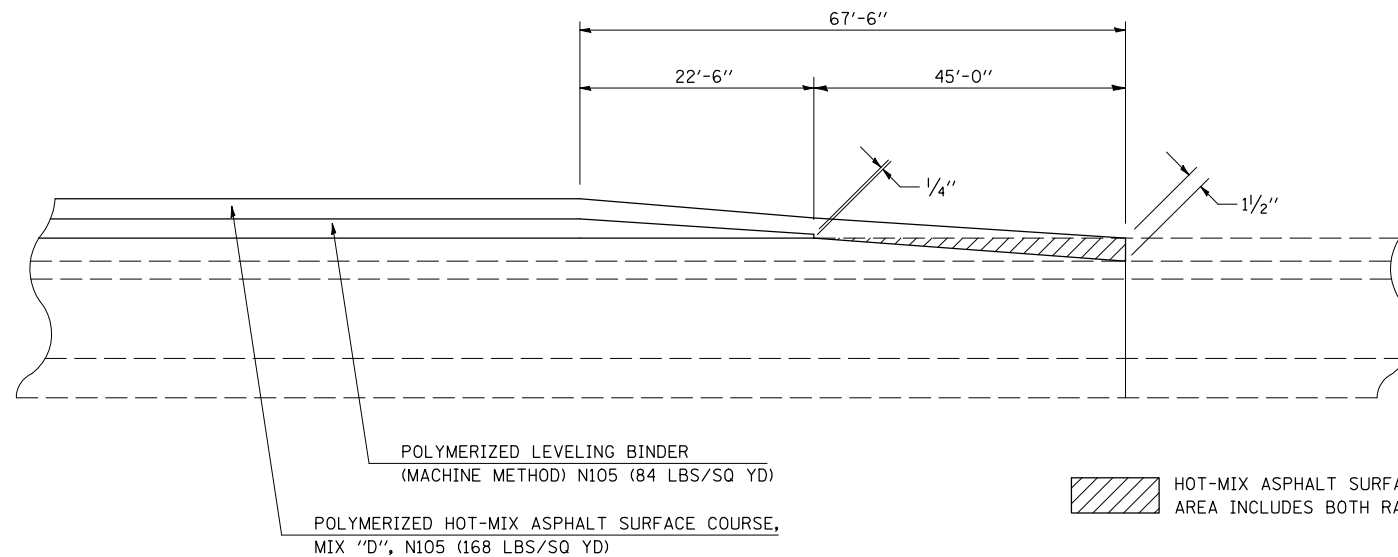

NOT TO SCALE

ILLINOIS DEPARTMENT OF TRANSPORTATION  
**DETAILS FOR RAMP INTERSECTION  
RESURFACING TRANSITIONS & BUTT JOINTS**

F.A.I. ROUTE 72  
SECTION (58,74-66)&(74-67&68)RS-1  
PIATT COUNTY  
*Sheet 2 of 4*

SCALE: NONE  
DATE: 12/18/09

DRAWN BY: CADD  
CHECKED BY: R.T.B.