

JOINT REPAIR DETAILS

S.N. 074-0063 & 074-0064

(EAST AND WEST ABUTMENT JOINTS)

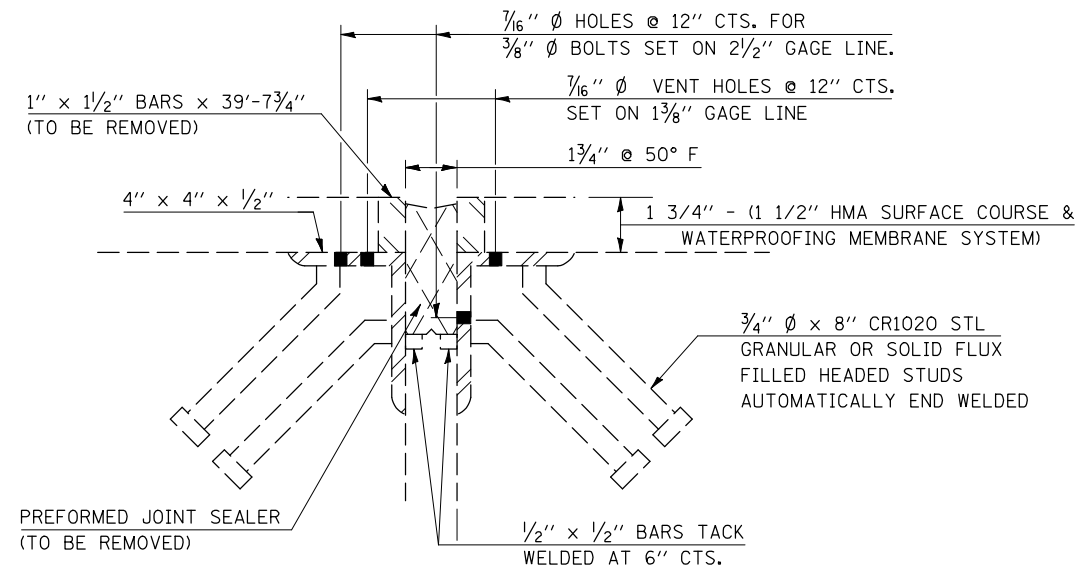

EXISTING JOINT

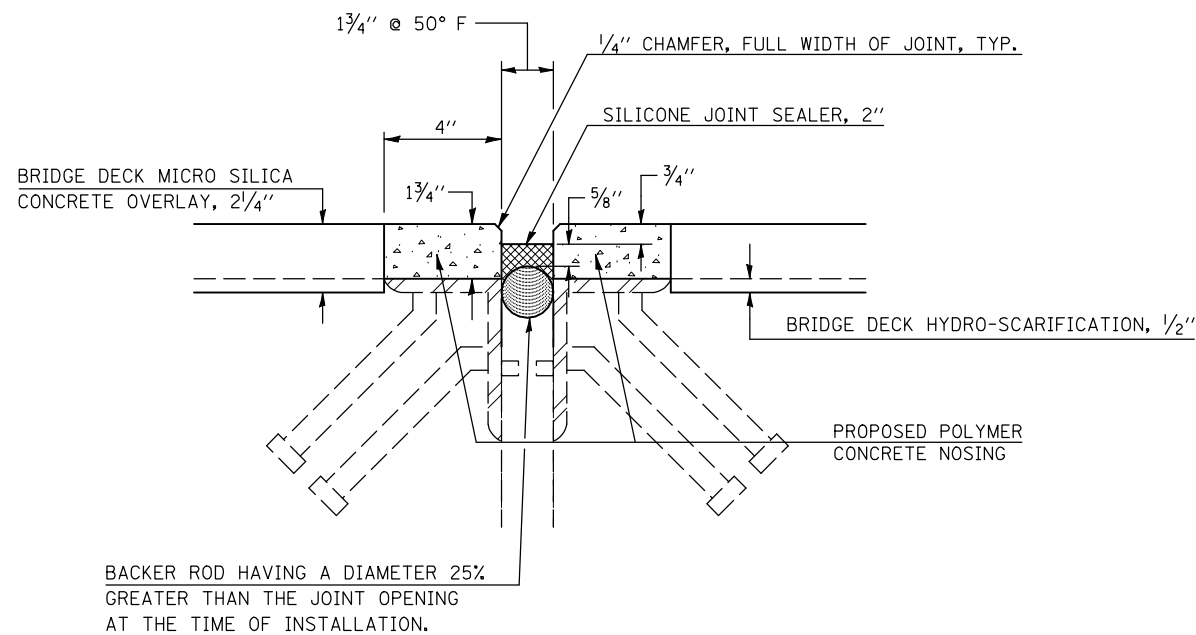

PROPOSED JOINT

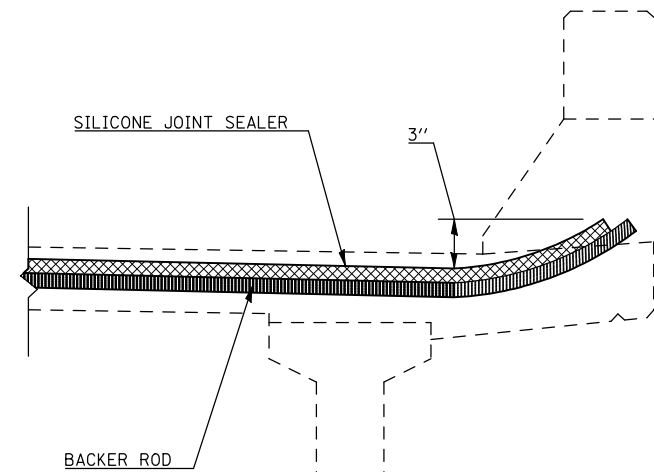

SECTION AT PARAPET
SILICONE JOINT SEALER

NOTES

REMOVE EXISTING PREFORMED JOINT SEALER AND 1" X 1/2" BARS (ARMOR EXTENSIONS) AND REPLACE WITH SILICONE JOINT SEALER AND POLYMER CONCRETE NOSING. COST OF ALL REMOVAL TO BE INCLUDED WITH SILICONE JOINT SEALER, 2".

BILL OF MATERIALS - TWO STRUCTURES

ITEM	UNIT	TOTAL
SILICONE JOINT SEALER, 2"	FOOT	165.0
POLYMER CONCRETE	CU FT	16.0

FILE NAME =	USER NAME = ppersonbr	DESIGNED - GMS	REVISED -
ct:\pw\work\p\dot\personbr\d0109687\70022-Bridge Repair Plan.dgn		DRAWN - GMS	REVISED -
	PLOT SCALE = 40.0000' / IN.	CHECKED -	REVISED -
	PLOT DATE = 2/8/2010	DATE -	REVISED -

**STATE OF ILLINOIS
DEPARTMENT OF TRANSPORTATION**

**JOINT REPAIR DETAILS
S.N. 074-0063 & 074-0064**

SCALE: SHEET NO. 5 OF 9 SHEETS STA. TO STA.

F.A.I. RTE.	SECTION	COUNTY	TOTAL SHEETS	SHEET NO.
72	(58,74-66)&(74-67&68)RS-1	PIATT	251	167
CONTRACT NO. 70022			ILLINOIS FED. AID PROJECT	