

# EXPANSION JOINT MEDIAN TREATMENT S.N. 074-0055

( NORTH AND SOUTH ABUTMENT JOINTS )

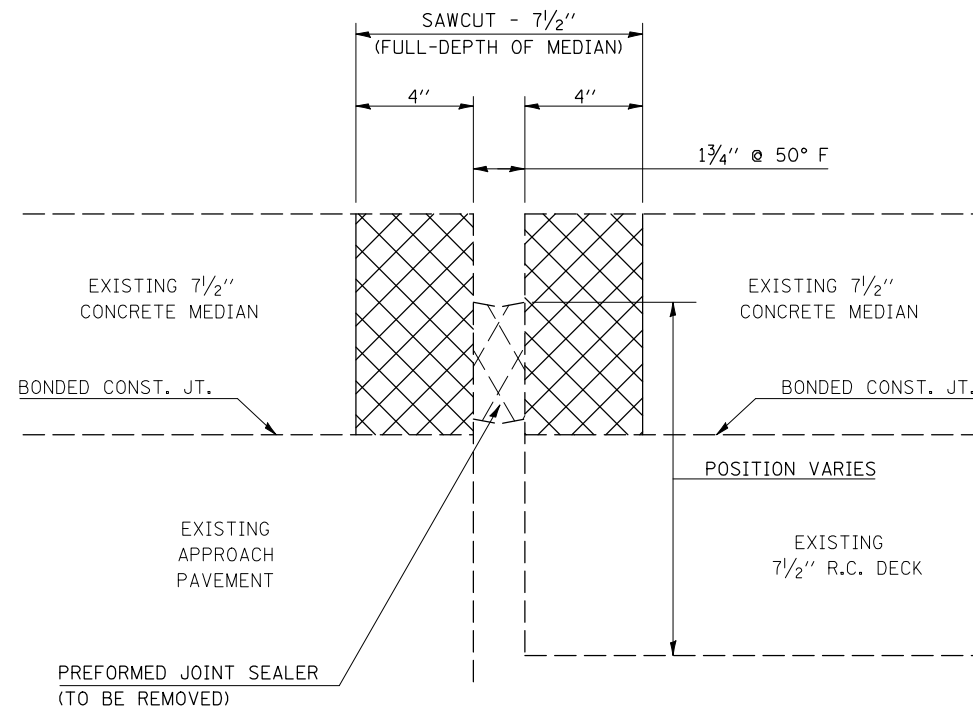

EXISTING JOINT  
( SECTION AT MEDIAN )

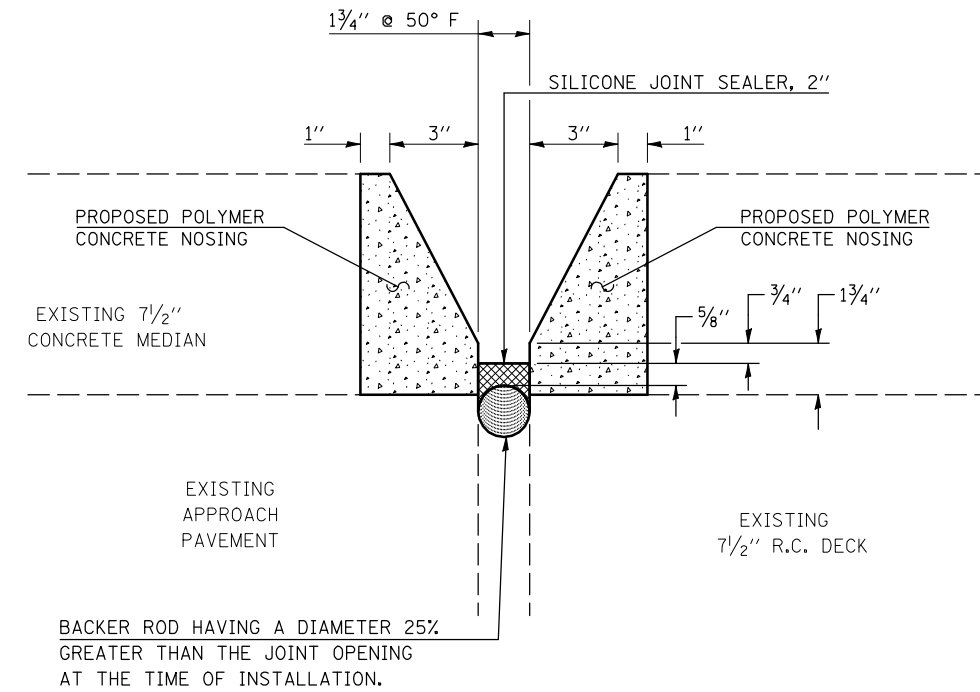

PROPOSED JOINT  
( SECTION A-A )

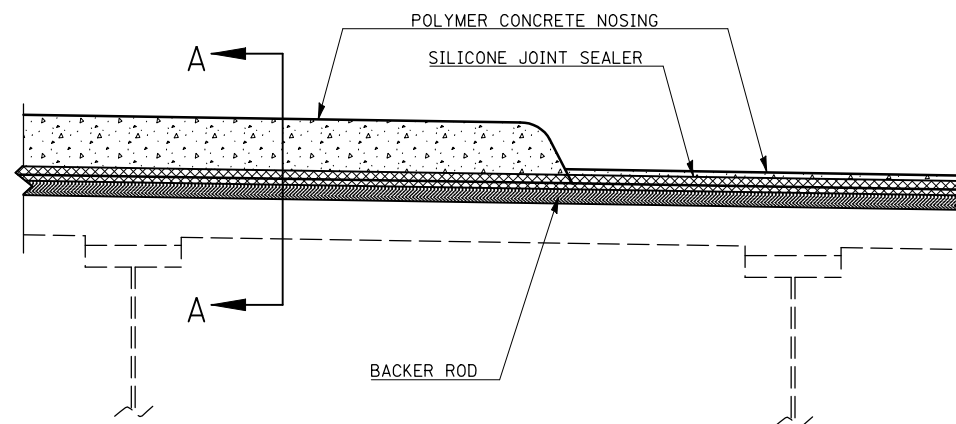

SECTION AT MEDIAN  
SILICONE JOINT SEALER

### NOTES

WHILE REMOVING THE PORTION OF THE BONDED CONCRETE MEDIAN AT THE JOINT, THE CONTRACTOR SHALL EXERCISE CARE TO AVOID DAMAGING THE DECK. AT THE ENGINEER'S DISCRETION, AREAS OF THE DECK OR APPROACH PAVEMENT DAMAGED BELOW THE BONDED JOINT SHALL EITHER BE REPAIRED WITH POLYMER CONCRETE IF ABOVE THE REINFORCEMENT, OR WITH PARTIAL-DEPTH PATCHING IF BELOW THE REINFORCEMENT, AND WILL NOT BE MEASURED FOR PAYMENT.

QUANTITIES FOR POLYMER CONCRETE AND SILICONE JOINT SEALER, 2" ARE INCLUDED ON SHEET 7 OF 14.

### BILL OF MATERIALS

ITEM	UNIT	TOTAL
CONCRETE REMOVAL	CU YD	0.5