

Vollmer Road
 EXISTING TYPICAL SECTION
 STA. 52+36 TO STA. 59+54

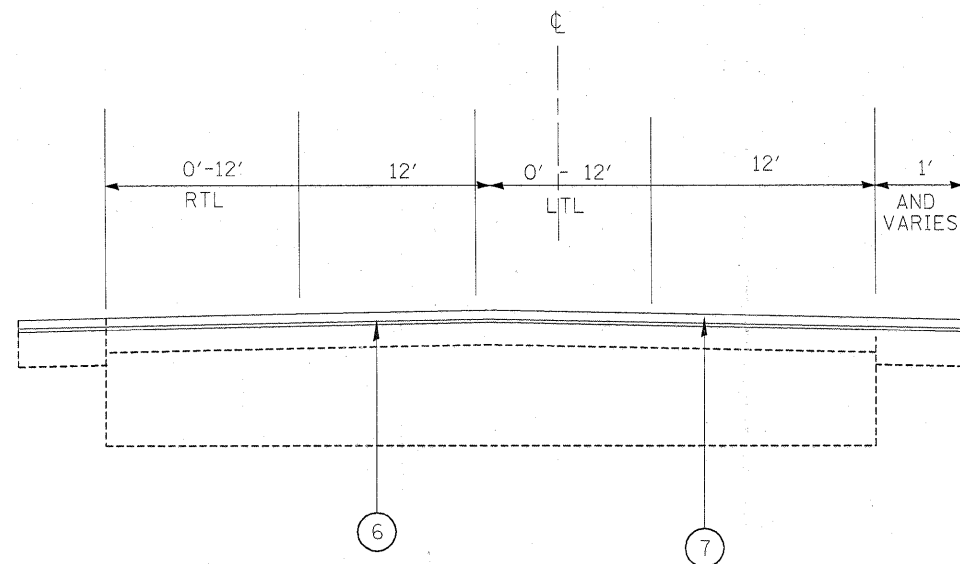

Vollmer Road
 PROPOSED TYPICAL SECTION
 STA. 52+36 TO STA. 59+24

LEGEND

- ① EXISTING P. C. C. PAVEMENT 10"
- ② EXISTING COMBINATION CONCRETE CURB AND GUTTER
- ③ EXISTING CORRUGATED MEDIAN TO BE MILLED FLUSH WITH ADJACENT ROADWAY (MEDIAN REMOVAL, PARTIAL DEPTH)
- ③A EXISTING HOT-MIX ASPHALT SHOULDER
- ④ EXISTING HOT-MIX ASPHALT SURFACE, 3" (±)
- ④A EXISTING AGGREGATE SHOULDER
- ⑤ PROPOSED HOT MIX ASPHALT SURFACE REMOVAL 2 1/4 "
- ⑥ PROPOSED POLYMERIZED LEVELING BINDER (MACHINE METHOD), IL-4.75, N50, 3/4"
- ⑦ PROPOSED HOT-MIX ASPHALT SURFACE COURSE, MIX "D", N70, 1 1/2"
- ⑧ PROPOSED P. C. C. SURFACE REMOVAL (VARIABLE DEPTH)
- ⑨ PROPOSED AGG. WEDGE SHOULDER TYPE, B
- ⑩ GRADING AND SHAPING SHOULDERS

FILE NAME =	USER NAME = banks1	DESIGNED -	REVISED -
cs:\pw_work\pwidot\banks1\017634\1\012731\shtrplan.dgn		DRAWN -	REVISED -
PLOT SCALE = 50,0000' / IN.		CHECKED -	REVISED -
PLOT DATE = 2/4/2010		DATE -	REVISED -

STATE OF ILLINOIS
 DEPARTMENT OF TRANSPORTATION

VOLLMER ROAD - ILL 1 (HALSTED STREET TO HOLBROOK ROAD)
 TYPICAL SECTIONS

SCALE: NONE SHEET NO. OF SHEETS STA. TO STA.

F.A.U. RTE.	SECTION	COUNTY	TOTAL SHEETS	SHEET NO.
3603	2009-125 RS	COOK	23	8
CONTRACT NO. 60J83				
ILLINOIS FED. AID PROJECT				