

Vollmer Road
EXISTING TYPICAL SECTION
 STA. 20+93 TO STA. 47+24
 STA. 49+57 TO STA. 52+36

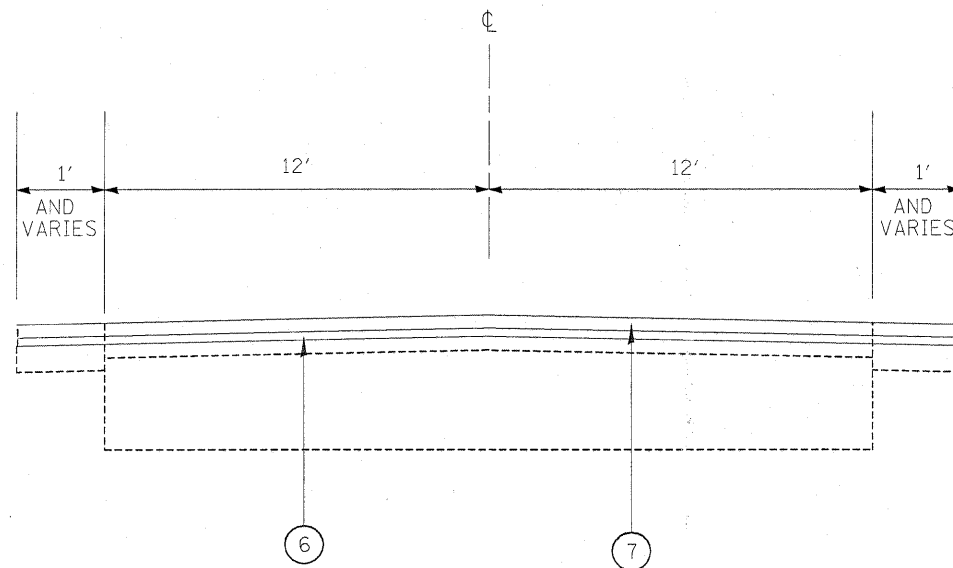

Vollmer Road
PROPOSED TYPICAL SECTION
 STA. 20+93 TO STA. 47+24
 STA. 49+57 TO STA. 52+36

LEGEND

- ① EXISTING P. C. C. PAVEMENT 10"
- ② EXISTING COMBINATION CONCRETE CURB AND GUTTER
- ③ EXISTING CORRUGATED MEDIAN TO BE MILLED FLUSH WITH ADJACENT ROADWAY (MEDIAN REMOVAL, PARTIAL DEPTH)
- ③A EXISTING HOT-MIX ASPHALT SHOULDER
- ④ EXISTING HOT-MIX ASPHALT SURFACE, 3" (±)
- ④A EXISTING AGGREGATE SHOULDER
- ⑤ PROPOSED HOT MIX ASPHALT SURFACE REMOVAL 2 1/4 "
- ⑥ PROPOSED POLYMERIZED LEVELING BINDER (MACHINE METHOD), IL-4.75, N50, 3/4"
- ⑦ PROPOSED HOT-MIX ASPHALT SURFACE COURSE, MIX "D", N70, 1 1/2"
- ⑧ PROPOSED P. C. C. SURFACE REMOVAL (VARIABLE DEPTH)
- ⑨ PROPOSED AGG. WEDGE SHOULDER TYPE, B
- ⑩ GRADING AND SHAPING SHOULDERS

FILE NAME = c:\pwork\pwork\banksl\08176341\0127310-shd-plen.dgn	USER NAME = banksl	DESIGNED -	REVISED -	STATE OF ILLINOIS DEPARTMENT OF TRANSPORTATION	VOLLMER ROAD - ILL 1 (HALSTED STREET TO HOLBROOK ROAD) TYPICAL SECTIONS	F.A.U. RTE.	SECTION	COUNTY	TOTAL SHEETS	SHEET NO.
	PLOT SCALE = 50.1380' / IN.	DRAWN -	REVISED -			3603	2009-125 RS	COOK	23	6
PLOT DATE = 2/4/2010	CHECKED -	REVISED -	SCALE: SHEET NO. OF SHEETS STA. TO STA.			FED. ROAD DIST. NO. 1 ILLINOIS FED. AID PROJECT				
	DATE -	REVISED -				CONTRACT NO. 60J83				