

FAI RTE 180	SECTION 2020-250-BY	COUNTY WILL	TOTAL SHEETS 133	SHEET NO. 1
FED. AID PROJECT		ILLINOIS	CONTRACT NO. 62N20	

D-91-060-21

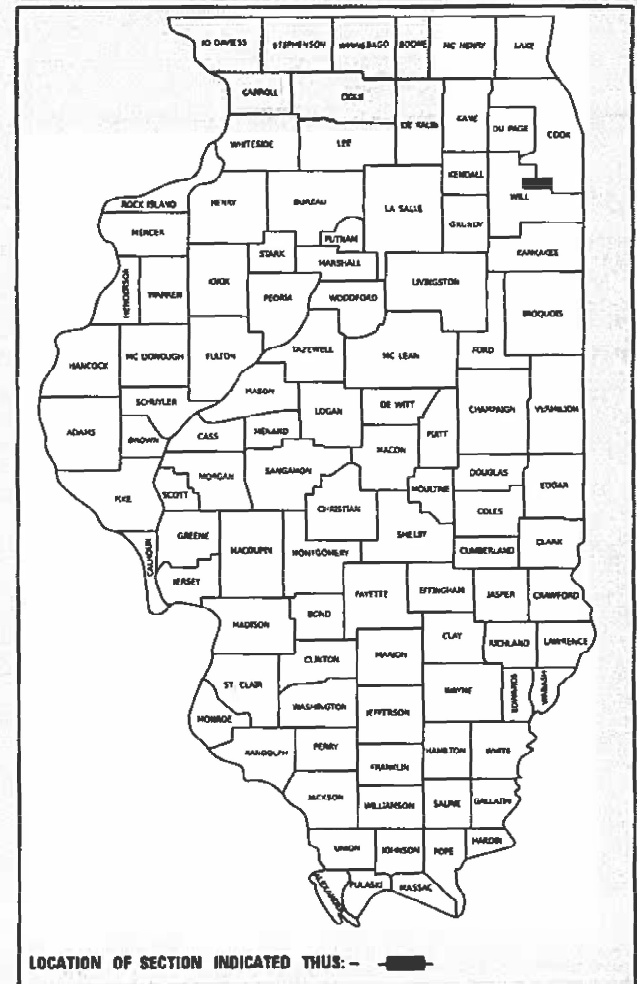

STATE OF ILLINOIS
DEPARTMENT OF TRANSPORTATION

**PROPOSED
HIGHWAY PLANS**

**FAI 80 / I-80 AT
WOLF ROAD
SECTION 2020-250-BY
PROJECT NHPP-L1G7(983)
BRIDGE NEW DECK AND BRIDGE WIDENING
(S.N. 099-0192)
WILL COUNTY**

<p>PRIMERA ENGINEERS LTD. ROBERT J. DEMING, P.E. DATE: 01/28/2022 SIGNATURE AND SEAL APPLY TO DRAWINGS: 1 - 39 EXPIRES: 11/30/2023</p>	<p>PRIMERA ENGINEERS LTD. ZAIDA MORILLO, P.E., S.E. DATE: 01/28/2022 SIGNATURE AND SEAL APPLY TO DRAWINGS: 63 - 100 EXPIRES: 11/30/2022</p>
--	---

ROGERS S. LOCKWOOD
DATE SIGNED: 1/28/2022
LICENSE EXP. DATE: 11/29/2023
SIGNATURE AND SEAL
APPLY TO DRAWINGS:
40 - 46

FOR INDEX OF SHEETS, SEE SHEET NO. 2

PROJECT IS LOCATED IN THE VILLAGE
OF MOKENA IN WILL COUNTY

WOLF ROAD TRAFFIC DATA:
FUNCTIONAL CLASSIFICATION
MINOR ARTERIAL
2019 ADT = 15800
SPEED LIMIT = 35 MPH
I-80 TRAFFIC DATA:
FUNCTIONAL CLASSIFICATION
INTERSTATE
2022 ADT = 102300
SPEED LIMIT = 65 MPH

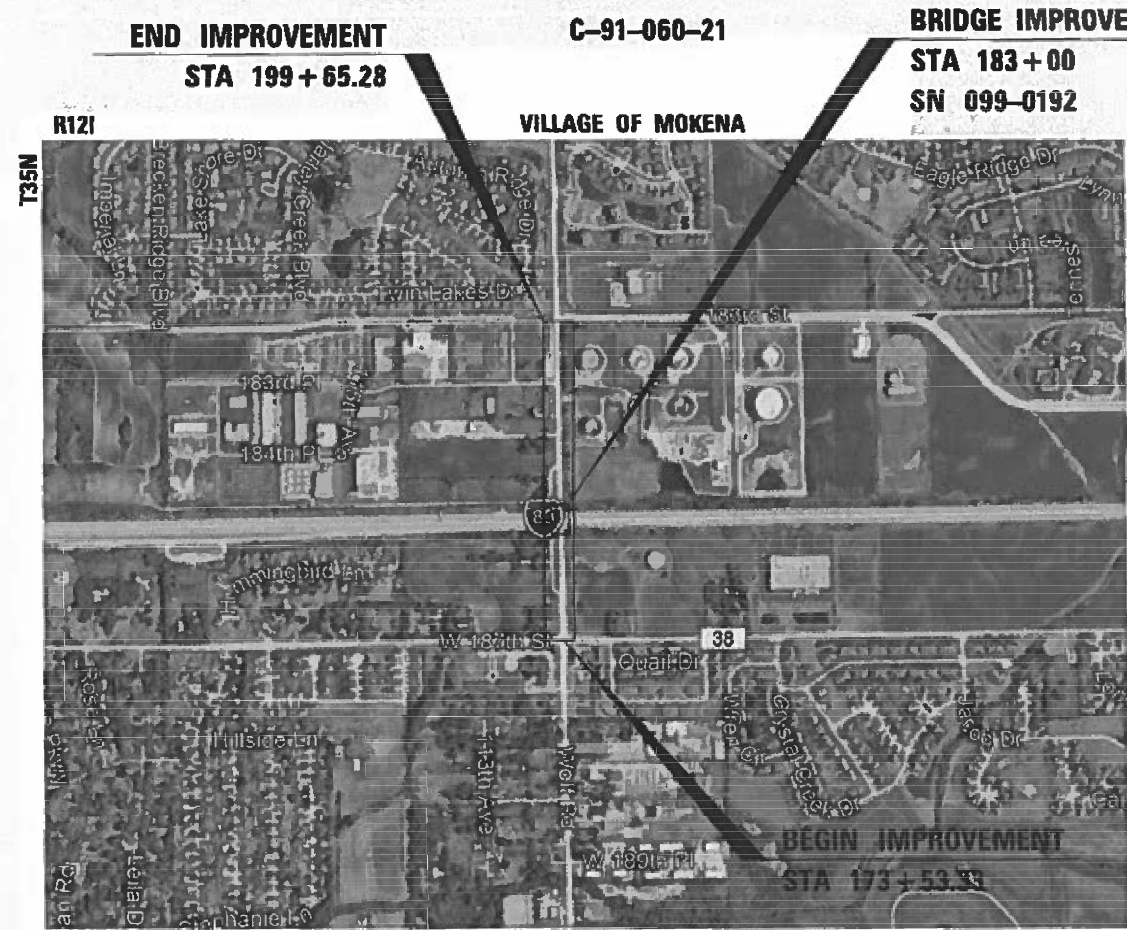

N
LOCATION MAP
NOT TO SCALE

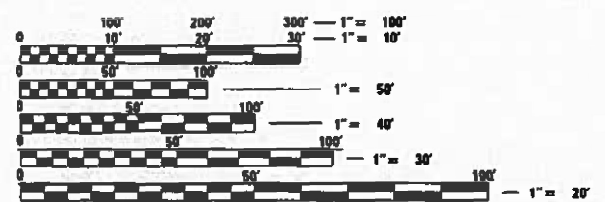

FULL SIZE PLANS HAVE BEEN PREPARED USING STANDARD
ENGINEERING SCALES. REDUCED SIZED PLANS WILL NOT
CONFORM TO STANDARD SCALES. IN MAKING MEASUREMENTS
ON REDUCED PLANS, THE ABOVE SCALES MAY BE USED.

J.U.L.I.E.
JOINT UTILITY LOCATION INFORMATION FOR EXCAVATORS
1-800-892-0123
OR 811

PROJECT ENGINEER PRAVEEN KAINI, PE
(847) 705-4237
PROJECT MANAGER J. ALAIN MIDY, PE
(847) 221-3056
CONTRACT NO. 62N20

SECTIONS 5 & 6
GROSS LENGTH = 2,612 FT. = 0.495 MILE
NET LENGTH = 2,612 FT. = 0.495 MILE



STATE OF ILLINOIS
DEPARTMENT OF TRANSPORTATION
SUBMITTED FEBRUARY 1, 2022
Jose Rios
March 25, 2022
REGIONAL ENGINEER
Stephen M. Zaida
March 22, 2022
ENGINEER OF DESIGN AND ENVIRONMENT
DIRECTOR OF HIGHWAYS PROJECT IMPLEMENTATION

**PRINTED BY THE AUTHORITY
OF THE STATE OF ILLINOIS**

MODEL: D:\default...
 FILE: M:\GIS...
 300 N JACKSON BLVD SUITE 600 CHICAGO IL 60611 P.312.465.4111 F.312.465.4115

CODE NO.	ITEM	UNIT	TOTAL QUANTITY URBAN	CONSTRUCTION CODE	
				BRIDGE 0013	90% FED 10% STATE
				WOLF RD SN 099-0192	
20100110	TREE REMOVAL (6 TO 15 UNITS DIAMETER)	UNIT	150	150	
20100210	TREE REMOVAL (OVER 15 UNITS DIAMETER)	UNIT	25	25	
20101000	TEMPORARY FENCE	FOOT	100	100	
20200100	EARTH EXCAVATION	CU YD	383	383	
20400800	FURNISHED EXCAVATION	CU YD	6106	6106	
20800150	TRENCH BACKFILL	CU YD	242	242	
25003210	INTERSEEDING, CLASS 2A	ACRE	1	1	
25100125	MULCH, METHOD 3	ACRE	1	1	
21101505	TOPSOIL EXCAVATION AND PLACEMENT	CU YD	824	824	
21101615	TOPSOIL FURNISH AND PLACE, 4"	SQ YD	5883	5883	
25000210	SEEDING, CLASS 2A	ACRE	0.5	0.5	
25000400	NITROGEN FERTILIZER NUTRIENT	POUND	46	46	
25000600	POTASSIUM FERTILIZER NUTRIENT	POUND	46	46	
25100635	HEAVY DUTY EROSION CONTROL BLANKET	SQ YD	2473	2473	
28000305	TEMPORARY DITCH CHECKS	FOOT	275	275	
28000400	PERIMETER EROSION BARRIER	FOOT	1584	1584	
28000500	INLET AND PIPE PROTECTION	EACH	3	3	
31200500	STABILIZED SUBBASE - HOT-MIX ASPHALT, 4"	SQ YD	118	118	
35101600	AGGREGATE BASE COURSE, TYPE B 4"	SQ YD	3795	3795	
35501308	HOT-MIX ASPHALT BASE COURSE, 6"	SQ YD	40	40	
40600290	BITUMINOUS MATERIALS (TACK COAT)	POUND	1853	1853	
40600400	MIXTURE FOR CRACKS, JOINTS, AND FLANGEWAYS	TON	5	5	
40600982	HOT-MIX ASPHALT SURFACE REMOVAL - BUTT JOINT	SQ YD	170	170	
40603085	HOT-MIX ASPHALT BINDER COURSE, IL-19.0, N70	TON	529	529	
40604060	HOT-MIX ASPHALT SURFACE COURSE, IL-9.5, MIX "D", N50	TON	5	5	
40604062	HOT-MIX ASPHALT SURFACE COURSE, IL-9.5, MIX "D", N70	TON	353	353	
42000080	PAVEMENT CONNECTOR (PCC) FOR BRIDGE APPROACH SLAB	SQ YD	147	147	
42001300	PROTECTIVE COAT	SQ YD	4195	4195	
42400200	PORTLAND CEMENT CONCRETE SIDEWALK 5 INCH	SQ FT	34155	34155	
42400800	DETECTABLE WARNINGS	SQ FT	200	200	
44000100	PAVEMENT REMOVAL	SQ YD	297	297	
44000600	SIDEWALK REMOVAL	SQ FT	200	200	
44000164	HOT-MIX ASPHALT SURFACE REMOVAL, 3 3/4"	SQ YD	3821	3821	
44000500	COMBINATION CURB AND GUTTER REMOVAL	FOOT	75	75	
44001980	CONCRETE BARRIER REMOVAL	FOOT	99	99	
44004250	PAVED SHOULDER REMOVAL	SQ YD	2148	2148	



USER NAME = rvandermus	DESIGNED - RM/RMV	REVISED -
PLOT SCALE = 2.0000 / in.	DRAWN - RM/RMV	REVISED -
PLOT DATE = 2/4/2022	CHECKED - MPV	REVISED -
	DATE - 07/07/2021	REVISED -

STATE OF ILLINOIS
DEPARTMENT OF TRANSPORTATION

SCALE:		SHEET	OF	SHEETS	STA.	TO	STA.
--------	--	-------	----	--------	------	----	------

F.A.P. RTE.	SECTION	COUNTY	TOTAL SHEETS	SHEET NO.
2688	2020-250-BY	WILL	133	3
CONTRACT NO. 62N20				
ILLINOIS FED. AID PROJECT				

MODEL: Default
 FILE: M:\GIS\Projects\2020\20200425.00 - DDOT Phase II Various Design\20200425.01_WO 1-3 - Wolf Road over I-80\Drawings\Current Drawing Files\CADD_Sheets\Roadway\0113233-ah-500-02.dgn
 301 W JACKSON BLVD SUITE 400 CHICAGO IL 60601 P.312.465.4111 F.312.465.4115

CODE NO.	ITEM	UNIT	TOTAL QUANTITY URBAN	CONSTRUCTION CODE	
				90% FED 10% STATE	WOLF RD
44200970	CLASS B PATCHES, TYPE II, 10 INCH	SQ YD	9		9
44200974	CLASS B PATCHES, TYPE III, 10 INCH	SQ YD	528		528
44200976	CLASS B PATCHES, TYPE IV, 10 INCH	SQ YD	50		50
44201299	DOWEL BARS 1 1/2"	EACH	1452		1452
44201765	CLASS D PATCHES, TYPE II, 10 INCH	SQ YD	500		500
44201769	CLASS D PATCHES, TYPE III, 10 INCH	SQ YD	100		100
44201771	CLASS D PATCHES, TYPE IV, 10 INCH	SQ YD	125		125
44213200	SAW CUTS	FOOT	4476		4476
48101620	AGGREGATE SHOULDERS, TYPE B 10"	SQ YD	436		436
48203029	HOT-MIX ASPHALT SHOULDERS, 8"	SQ YD	1897		1897
48300705	PORTLAND CEMENT CONCRETE SHOULDERS 12 1/4"	SQ YD	23		23
50101500	REMOVAL OF EXISTING SUPERSTRUCTURES	EACH	1		1
50102400	CONCRETE REMOVAL	CU YD	33.2		33.2
50104650	SLOPE WALL REMOVAL	SQ YD	370		370
50157300	PROTECTIVE SHIELD	SQ YD	598		598
50200100	STRUCTURE EXCAVATION	CU YD	226.0		226.0
50300225	CONCRETE STRUCTURES	CU YD	195.3		195.3
50300255	CONCRETE SUPERSTRUCTURE	CU YD	379.9		379.9
50300260	BRIDGE DECK GROOVING	SQ YD	941		941
50300300	PROTECTIVE COAT	SQ YD	1771		1771
50301350	CONCRETE SUPERSTRUCTURE (APPROACH SLAB)	CU YD	125.8		125.8
50500105	FURNISHING AND ERECTING STRUCTURAL STEEL	L SUM	1		1
50500505	STUD SHEAR CONNECTORS	EACH	9891		9891
50800205	REINFORCEMENT BARS, EPOXY COATED	POUND	229850		229850
50901720	BICYCLE RAILING	FOOT	1031		1031
* 50901730	BRIDGE FENCE RAILING	FOOT	278		278
* 50901735	BRIDGE FENCE RAILING (SIDEWALK)	FOOT	282		282
* 50901750	PARAPET RAILING	FOOT	278		278
51100100	SLOPE WALL 4 INCH	SQ YD	478		478
* 51200957	FURNISHING METAL SHELL PILES 12" X 0.250"	FOOT	135		135
* 51200963	FURNISHING METAL SHELL PILES 16" X 0.375"	FOOT	1272		1272
* 51202305	DRIVING PILES	FOOT	1407		1407
* 51203200	TEST PILE METAL SHELLS	EACH	3		3
* 51204650	PILE SHOES	EACH	28		28
51500100	NAME PLATES	EACH	2		2

*** SPECIALTY ITEM**

	USER NAME = rmartin	DESIGNED - RM/RMV	REVISED -
	PLOT SCALE = 2.0000 / in.	DRAWN - RM/RMV	REVISED -
	PLOT DATE = 2/2/2022	CHECKED - MPV	REVISED -
		DATE - 07/07/2021	REVISED -

**STATE OF ILLINOIS
DEPARTMENT OF TRANSPORTATION**

**SUMMARY OF QUANTITIES
WOLF ROAD BRIDGE OVER I-80**

SCALE: SHEET OF SHEETS STA. TO STA.

F.A.P. RTE.	SECTION	COUNTY	TOTAL SHEETS	SHEET NO.
2688	2020-250-BY	WILL	133	4
CONTRACT NO. 62N20			ILLINOIS FED. AID PROJECT	

MODEL: Default
 FILE: M:\GIS\Projects\primera-pw-bentley.com\primera-pw-01\Documents\01 - Project\2020\20200425.00 - DOT Phase II Various Design\20200425.01.WD.1.3 - Wolf Road over I-80\Drawings\Current Drawing Files\CADD_Sheets\Roadway\0113233-ink-500-03.dgn
 301 W JACKSON BLVD SUITE 400 CHICAGO IL 60601 P.312.465.4010 F.312.465.4015

CODE NO.	ITEM	UNIT	TOTAL QUANTITY URBAN	CONSTRUCTION CODE	
				BRIDGE 0013	90% FED 10% STATE
				WOLF RD	
52100010	ELASTOMERIC BEARING ASSEMBLY, TYPE 1	EACH	28	28	
52100505	ANCHOR BOLTS, 5/8"	EACH	28	28	
52100510	ANCHOR BOLTS, 3/4"	EACH	42	42	
550A0070	STORM SEWERS, CLASS A, TYPE 1 15"	FOOT	202	202	
550A0090	STORM SEWERS, CLASS A, TYPE 1 18"	FOOT	133	133	
550A0120	STORM SEWERS, CLASS A, TYPE 1 24"	FOOT	17	17	
54213660	PRECAST REINFORCED CONCRETE FLARED END SECTIONS 15"	EACH	5	5	
54213663	PRECAST REINFORCED CONCRETE FLARED END SECTIONS 18"	EACH	3	3	
55100500	STORM SEWER REMOVAL 12"	FOOT	50	50	
55101200	STORM SEWER REMOVAL 24"	FOOT	17	17	
56400100	FIRE HYDRANTS TO BE MOVED	EACH	1	1	
58600101	GRANULAR BACKFILL FOR STRUCTURES	CU YD	382.0	382.0	
58700300	CONCRETE SEALER	SQ FT	1603	1603	
59000200	EPOXY CRACK INJECTION	FOOT	4	4	
59100100	GEOCOMPOSITE WALL DRAIN	SQ YD	99	99	
60108206	PIPE UNDERDRAINS, TYPE 2, 6"	FOOT	128	128	
60200805	CATCH BASINS, TYPE A, 4'-DIAMETER, TYPE 8 GRATE	EACH	1	1	
60201310	CATCH BASINS, TYPE A, 4'-DIAMETER, TYPE 20 FRAME AND GRATE	EACH	9	9	
60219510	MANHOLES, TYPE A, 4'-DIAMETER, TYPE 20 FRAME AND GRATE	EACH	2	2	
60221100	MANHOLES, TYPE A, 5'-DIAMETER, TYPE 1 FRAME, CLOSED LID	EACH	1	1	
60260100	INLETS TO BE ADJUSTED	EACH	2	2	
60500040	REMOVING MANHOLES	EACH	1	1	
60500060	REMOVING INLETS	EACH	16	16	
60605000	COMBINATION CONCRETE CURB AND GUTTER, TYPE B-6.24	FOOT	400	400	
63000001	STEEL PLATE BEAM GUARDRAIL, TYPE A, 6 FOOT POSTS	FOOT	1172	1172	
63000035	BACK SIDE PROTECTION OF GUARDRAIL	FOOT	586	586	
63100085	TRAFFIC BARRIER TERMINAL, TYPE 6	EACH	4	4	
63100167	TRAFFIC BARRIER TERMINAL, TYPE 1 (SPECIAL) TANGENT	EACH	6	6	
63200310	GUARDRAIL REMOVAL	FOOT	1174	1174	
63700280	CONCRETE BARRIER, DOUBLE FACE, 44 INCH HEIGHT	FOOT	4	4	
63700805	CONCRETE BARRIER TRANSITION	FOOT	64	64	
64200116	SHOULDER RUMBLE STRIPS, 16 INCH	FOOT	3116	3116	
* 66900200	NON-SPECIAL WASTE DISPOSAL	CU YD	250	250	
* 66901006	REGULATED SUBSTANCES MONITORING	CAL DA	20	20	
66901001	REGULATED SUBSTANCES PRE-CONSTRUCTION PLANS	L SUM	1	1	
* 66901003	REGULATED SUBSTANCES FINAL CONSTRUCTION REPORTS	L SUM	1	1	
* 66900530	SOIL DISPOSAL ANALYSIS	EACH	4	4	

*** SPECIALTY ITEM**



USER NAME = rvandermus	DESIGNED - RM/RMV	REVISED -
DRAWN - RM/RMV	REVISED -	
PLOT SCALE = 2.0000 / in.	CHECKED - MPV	REVISED -
PLOT DATE = 2/4/2022	DATE - 07/07/2021	REVISED -

**STATE OF ILLINOIS
DEPARTMENT OF TRANSPORTATION**

**SUMMARY OF QUANTITIES
WOLF ROAD BRIDGE OVER I-80**

SCALE: SHEET OF SHEETS STA. TO STA.

F.A.P. RTE.	SECTION	COUNTY	TOTAL SHEETS	SHEET NO.
2688	2020-250-BY	WILL	133	5
CONTRACT NO. 62N20			ILLINOIS FED. AID PROJECT	

MODEL: Default
 FILE: M:\CADD\Primera\p01\Documents\01 - Projects\2020\20200205.00 - IDOT Phase II Various Design\20200205.01.WD 1-3 - Wolf Road over I-80\Drawings\Current Drawing Files\CADD_Sheets\Roadway\0112323-ah-500-04.dgn
 201 W JACKSON BLVD, SUITE 600 CHICAGO IL 60601 P 312-465-6910 F 312-465-6415

CODE NO.	ITEM	UNIT	TOTAL QUANTITY URBAN	CONSTRUCTION CODE	
				BRIDGE	WOLF RD
67100100	MOBILIZATION	L SUM	1		1
70300150	SHORT TERM PAVEMENT MARKING REMOVAL	SQ FT	4172		4172
70307120	TEMPORARY PAVEMENT MARKING - LINE 4" - TYPE IV TAPE	FOOT	8649		8649
70307130	TEMPORARY PAVEMENT MARKING - LINE 6" - TYPE IV TAPE	FOOT	2577		2577
70400100	TEMPORARY CONCRETE BARRIER	FOOT	1200		1200
70400200	RELOCATE TEMPORARY CONCRETE BARRIER	FOOT	1200		1200
70600250	IMPACT ATTENUATORS, TEMPORARY (NON- REDIRECTIVE), TEST LEVEL 3	EACH	2		2
70600350	IMPACT ATTENUATORS, RELOCATE (NON- REDIRECTIVE), TEST LEVEL 3	EACH	2		2
* 72000100	SIGN PANEL - TYPE 1	SQ FT	64		64
* 72000200	SIGN PANEL - TYPE 2	SQ FT	24		24
* 72400100	REMOVE SIGN PANEL ASSEMBLY - TYPE A	EACH	11		11
* 72400310	REMOVE SIGN PANEL - TYPE 1	SQ FT	72		72
* 72400320	REMOVE SIGN PANEL - TYPE 2	SQ FT	48		48
72500300	OBJECT MARKER - TYPE 3	EACH	4		4
72501000	TERMINAL MARKER - DIRECT APPLIED	EACH	4		4
72800100	TELESCOPING STEEL SIGN SUPPORT	FOOT	200		200
72900100	METAL POST - TYPE A	FOOT	28		28
* 78000100	THERMOPLASTIC PAVEMENT MARKING - LETTERS AND SYMBOLS	SQ FT	37		37
* 78000200	THERMOPLASTIC PAVEMENT MARKING - LINE 4"	FOOT	6686		6686
* 78000400	THERMOPLASTIC PAVEMENT MARKING - LINE 6"	FOOT	12000		12000
* 78000600	THERMOPLASTIC PAVEMENT MARKING - LINE 12"	FOOT	500		500
* 78000650	THERMOPLASTIC PAVEMENT MARKING - LINE 24"	FOOT	41		41
* 78009004	MODIFIED URETHANE PAVEMENT MARKING - LINE 4"	FOOT	1248		1248
* 78100100	RAISED REFLECTIVE PAVEMENT MARKER	EACH	50		50
* 78200005	GUARDRAIL REFLECTORS, TYPE A	EACH	19		19
* 78200011	BARRIER WALL REFLECTORS, TYPE C	EACH	50		50
78300200	RAISED REFLECTIVE PAVEMENT MARKER REMOVAL	EACH	50		50
78300202	PAVEMENT MARKING REMOVAL - WATER BLASTING	SQ FT	9000		9000
* 81028200	UNDERGROUND CONDUIT, GALVANIZED STEEL, 2" DIA.	FOOT	1960		1960
81200230	CONDUIT EMBEDDED IN STRUCTURE, 2" DIA.,PVC	FOOT	282		282
* 81400100	HANDHOLE	EACH	2		2
81400100	HANDHOLE	EACH	2		2
* 81301290	JUNCTION BOX, STAINLESS STEEL, EMBEDDED IN STRUCTURE, 12" X 12" X 6"	EACH	2		2
* 85000200	MAINTENANCE OF EXISTING TRAFFIC SIGNAL INSTALLATION	EACH	2		2
* 86400100	TRANSCEIVER - FIBER OPTIC	EACH	1		1
* 87300925	ELECTRIC CABLE IN CONDUIT, TRACER, NO. 14 1C	FOOT	2750		2750
* 87301215	ELECTRIC CABLE IN CONDUIT, SIGNAL NO. 14 2C	FOOT	480		480

*** SPECIALTY ITEM**



USER NAME = rmartin	DESIGNED - RM/RMV	REVISED -
	DRAWN - RM/RMV	REVISED -
PLOT SCALE = 2.0000' / in.	CHECKED - MPV	REVISED -
PLOT DATE = 2/2/2022	DATE - 07/07/2021	REVISED -

STATE OF ILLINOIS
DEPARTMENT OF TRANSPORTATION

SCALE:				SHEET	OF	SHEETS	STA.	TO	STA.
--------	--	--	--	-------	----	--------	------	----	------

SUMMARY OF QUANTITIES
WOLF ROAD BRIDGE OVER I-80

F.A.P. RTE.	SECTION	COUNTY	TOTAL SHEETS	SHEET NO.
2688	2020-250-BY	WILL	133	6
CONTRACT NO. 62N20				
ILLINOIS FED. AID PROJECT				

MODEL: Default
 FILE: M:\GIS\Projects\2020\20200425.00 - DDOT Phase II Various Design\20200425.01_WO 1-3 - Wolf Road over I-80\Drawings\Current Drawing Files\CADD_Sheets\Roadway\0113233-ah-500-05.dgn
 301 N JACKSON BLVD SUITE 600 CHICAGO IL 60611 P-312-465-4010 F-312-465-4015

CODE NO.	ITEM	UNIT	TOTAL QUANTITY URBAN	CONSTRUCTION CODE	
				BRIDGE 0013	90% FED 10% STATE
				WOLF RD	
* 87301900	ELECTRIC CABLE IN CONDUIT, EQUIPMENT GROUNDING CONDUCTOR, NO. 6 1C	FOOT	110	110	
* 87900200	DRILL EXISTING HANDHOLE	EACH	5	5	
* 88102717	PEDESTRIAN SIGNAL HEAD, LED, 1-FACE, BRACKET MOUNTED WITH COUNTDOWN TIME	EACH	8	8	
* 88500100	INDUCTIVE LOOP DETECTOR	EACH	11	11	
* 88600100	DETECTOR LOOP, TYPE 1	FOOT	50	50	
* 89501410	RELOCATE EXISTING EMERGENCY VEHICLE PRIORITY SYSTEM, PHASING UNIT	EACH	1	1	
* 89502375	REMOVE EXISTING TRAFFIC SIGNAL EQUIPMENT	EACH	1	1	
K1005418	TEMPORARY SEEDING	ACRE	1	1	
X0320070	PROTECTIVE SHIELD REMOVAL	L SUM	1	1	
* 78011050	GROOVING FOR RECESSED PAVEMENT MARKING 10"	FOOT	1561	1561	
X0325201	SHOULDER RUMBLE STRIP REMOVAL	SQ YD	460	460	
X0327120	WEED CONTROL, NATIVE LANDSCAPE ENHANCEMENT	ACRE	1.7	1.7	
* X1400378	PEDESTRIAN SIGNAL POST, 5 FT.	EACH	3	3	
X2010350	TREE REMOVAL, ACRES (SPECIAL)	ACRE	0.25	0.25	
* 78004630	PREFORMED PLASTIC PAVEMENT MARKING, TYPE D - LINE 6"	FOOT	5830	5830	
* 78004645	PREFORMED PLASTIC PAVEMENT MARKING, TYPE D - LINE 9"	FOOT	1561	1561	
X4201410	BRIDGE APPROACH PAVEMENT CONNECTOR (SPECIAL)	SQ YD	40	40	
X6700407	ENGINEER'S FIELD OFFICE, TYPE A (D1)	CAL MO	12	12	
X7010216	TRAFFIC CONTROL AND PROTECTION, (SPECIAL)	L SUM	1	1	
X7010410	SPEED DISPLAY TRAILER	CAL MO	8	8	
X7011015	TRAFFIC CONTROL AND PROTECTION (EXPRESSWAYS)	L SUM	1	1	
X7013820	TRAFFIC CONTROL SURVEILLANCE, EXPRESSWAYS	CAL DA	210	210	
X7030005	TEMPORARY PAVEMENT MARKING REMOVAL	SQ FT	4138	4138	
* 78011035	GROOVING FOR RECESSED PAVEMENT MARKING 7"	FOOT	5830	5830	
* X8570226	FULL-ACTUATED CONTROLLER AND TYPE IV CABINET, SPECIAL	EACH	1	1	
* X8710024	FIBER OPTIC CABLE IN CONDUIT, NO. 62.5/125, MM12F SM24F	FOOT	2780	2780	
X8760200	ACCESSIBLE PEDESTRIAN SIGNALS	EACH	8	8	
X8780012	CONCRETE FOUNDATION, TYPE A 12-INCH DIAMETER	FOOT	12	12	
Z0004552	APPROACH SLAB REMOVAL	SQ YD	98	98	
Z0012754	STRUCTURAL REPAIR OF CONCRETE (DEPTH EQUAL TO OR LESS THAN 5 INCHES)	SQ FT	125	125	
Z0013798	CONSTRUCTION LAYOUT	L SUM	1	1	
Z0022800	FENCE REMOVAL	FOOT	94	94	
Z0029604	HEADWALL REMOVAL	EACH	4	4	
Z0030850	TEMPORARY INFORMATION SIGNING	SQ FT	200	200	
* Z0033046	RE-OPTIMIZE TRAFFIC SIGNAL SYSTEM LEVEL 2	EACH	1	1	

*** SPECIALTY ITEM**

	USER NAME = rmartin	DESIGNED - RM/RMV	REVISED -
		DRAWN - RM/RMV	REVISED -
	PLOT SCALE = 2.0000' / in.	CHECKED - MPV	REVISED -
	PLOT DATE = 2/2/2022	DATE - 07/07/2021	REVISED -

**STATE OF ILLINOIS
DEPARTMENT OF TRANSPORTATION**

**SUMMARY OF QUANTITIES
WOLF ROAD BRIDGE OVER I-80**

SCALE: SHEET OF SHEETS STA. TO STA.

F.A.P. RTE.	SECTION	COUNTY	TOTAL SHEETS	SHEET NO.
2688	2020-250-BY	WILL	133	7
CONTRACT NO. 62N20			ILLINOIS FED. AID PROJECT	

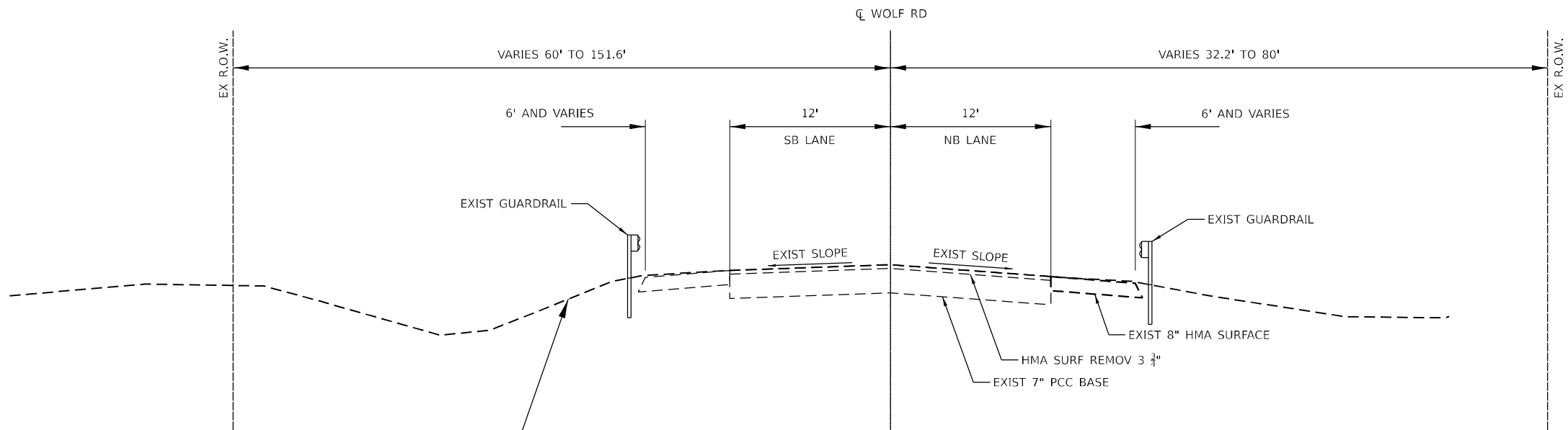

**EXISTING WOLF RD. TYPICAL SECTION
(LOOKING NORTH)**

STA. 173+50 TO STA. 181+61
BRIDGE OMISSION STA. 181+61 TO STA. 184+25
STA. 184+25 TO STA. 191+00

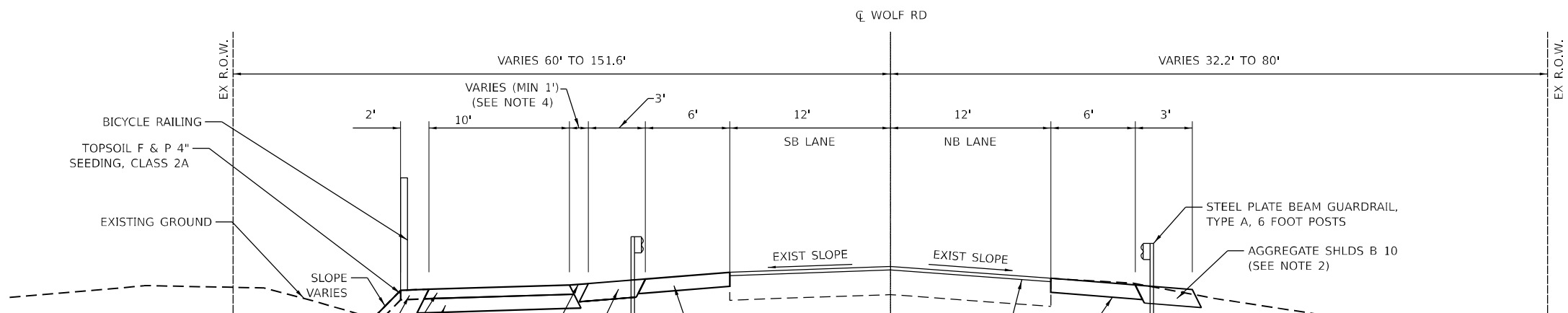

**PROPOSED WOLF RD. TYPICAL SECTION
(LOOKING NORTH)**

STA. 174+00 TO STA. 181+62
BRIDGE OMISSION STA. 181+62 TO 184+23
STA. 184+23 TO STA. 195+25

1. SHOULDER WORK APPLICABLE FROM STA. 174+00 TO STA. 181+80 AND FROM STA. 184+05 TO 191+08.
2. AGGREGATE SHOULDERS TO BE PLACED AT PROPOSED GUARDRAIL LOCATIONS.
3. SURFACE COURSE AND BINDER COURSE APPLICABLE FROM STA. 178+23 TO 181+37 AND FROM STA. 184+48 TO 195+25.
4. SEEDING CL 2A SHALL BE ADDED TO THIS TURF AREA WHEN THE WIDTH IS GREATER THAN 1'.

MIXTURE TYPE	AIR VOIDS	QUALITY MANAGEMENT PROGRAM (QMP)
HOT-MIX ASPHALT PAVEMENT (WOLF ROAD), 3.75"		
HOT-MIX ASPHALT SURFACE COURSE, MX "D", N70, 1.5" (L-9.5mm)	4% @ 70 Gyr.	QC/QA
HOT-MIX ASPHALT BINDER COURSE (IL-19.0), N70, 2.25"	4% @ 70 Gyr.	QC/QA
HOT-MIX ASPHALT SHOULDERS, 8" (WOLF ROAD & I-80)		
HOT-MIX ASPHALT SURFACE COURSE, MX "D", N70, 2" (L-9.5mm)	4% @ 70 Gyr.	QC/QA
HOT-MIX ASPHALT BINDER COURSE 6", (IL-19.0), N70	4% @ 70 Gyr.	QC/QA
PATCHING (WOLF ROAD)		
CLASS D PATCHES (HMA BINDER IL-19.0)	4% @ 70 Gyr.	QC/QA
HOT-MIX ASPHALT DRIVEWAYS		
HOT-MIX ASPHALT SURFACE COURSE, MX "D", IL-9.5, N50, 2"	4% @ 50 Gyr.	QC/QA
HOT-MIX ASPHALT BASE COURSE, 6" (HMA BINDER IL-19.0)	4% @ 50 Gyr.	QC/QA
SHOULDER RUMBLE STRIP REMOVAL		
HOT-MIX ASPHALT SURFACE COURSE, MX "D", N70, 2" (L-9.5mm)	4% @ 70 Gyr.	QC/QA
STABILIZED SUB-BASE HOT-MIX ASPHALT 4" (HMA BINDER IL-19.0)	3% @ 50 Gyr.	QC/QA

QMP DESIGNATION: QUALITY CONTROL/QUALITY ASSURANCE (QC/QA), QUALITY CONTROL FOR PERFORMANCE (QCP)
THE UNIT WEIGHT USED TO CALCULATE ALL HMA SURFACE MIXTURE QUANTITIES IS 112 LBS/SQ YD/IN.

The "AC Type" for Polymerized HMA Mixes SHALL BE "SBS/SBR PG 76 -22" AND FOR NON-POLYMERIZED HMA THE "AC TYPE" shall be "PG 64 -22" UNLESS modified by RECLAIMED MATERIALS SPECIFICATIONS.

MODEL: Default
 FILE: I:\MISC\primera\performance\pav\01\Documents\01\Documents\01\Drawings\Current\Drawings\Files\CADD_Sheets\Roadway\01132332-rt-typical.dgn
 Project: 20200405_00 - IDOT Phase II Veribus Design\20200405_01_WO 1-3 - Wolf Road over I-80\Drawings\Current\Drawings\Files\CADD_Sheets\Roadway\01132332-rt-typical.dgn
 460 N. JACKSON BLVD, SUITE 600, CHICAGO, IL 60611, P.312-467-4000 F.312-467-4005



USER NAME = rmandemus	DESIGNED - RM/RMV	REVISED -
PLOT SCALE = 2,000' / in.	DRAWN - RM/RMV	REVISED -
PLOT DATE = 3/16/2022	CHECKED - MPV	REVISED -
	DATE - 07/07/2021	REVISED -

**STATE OF ILLINOIS
DEPARTMENT OF TRANSPORTATION**

**TYPICAL SECTIONS
WOLF ROAD BRIDGE OVER I-80**

SCALE: SHEET OF SHEETS STA. TO STA.

F.A.I. RTE.	SECTION	COUNTY	TOTAL SHEETS	SHEET NO.
I-80	2020-250-BY	WILL	133	9
			CONTRACT NO. 62N20	
ILLINOIS FED. AID PROJECT				

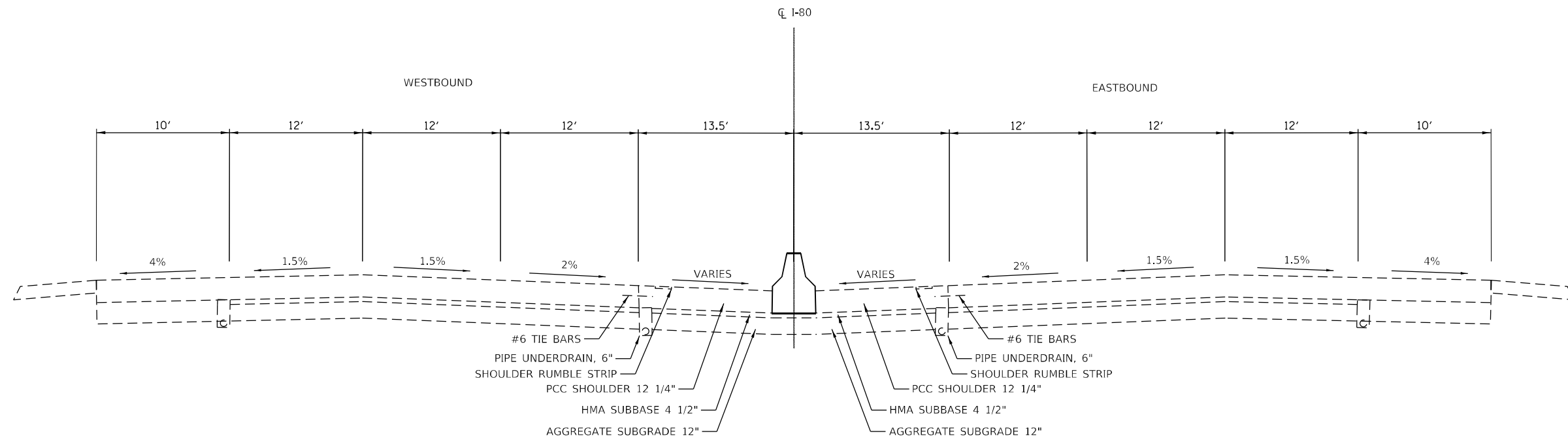

**EXISTING I-80 TYPICAL SECTION
(LOOKING EAST)**

STA. 173+50 TO STA. 181+61
BRIDGE OMISSION STA. 181+61 TO STA. 184+25
STA. 184+25 TO STA. 191+00

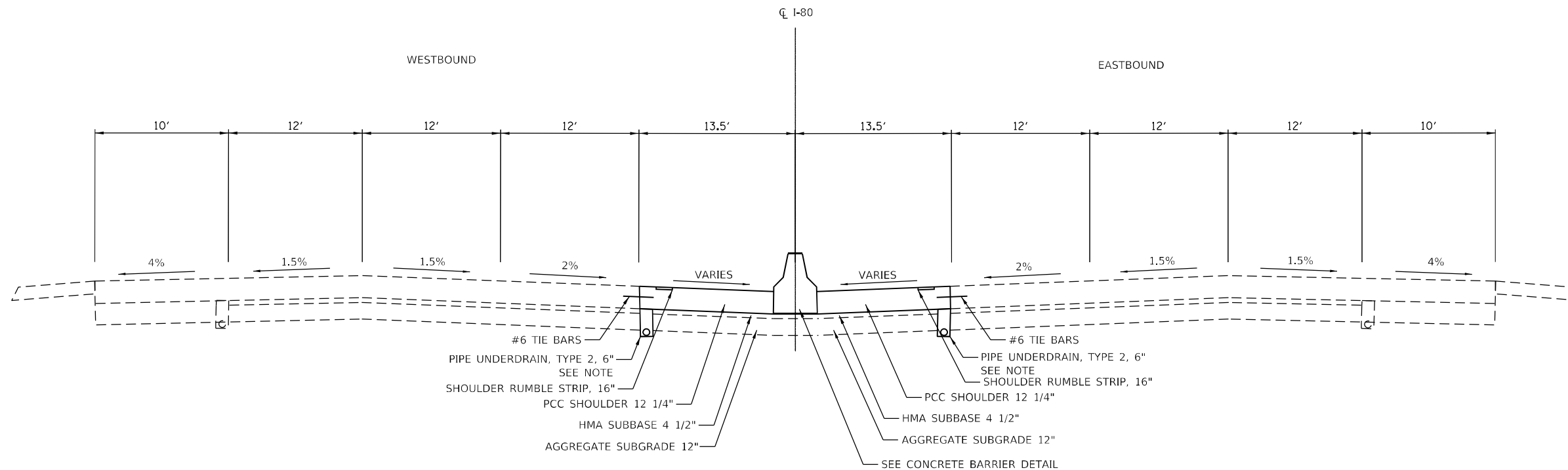

**PROPOSED I-80 TYPICAL SECTION
(LOOKING EAST)**

STA. 173+50 TO STA. 181+51.72
BRIDGE OMISSION STA. 181+51.72 TO STA. 184+33.80
STA. 184+33.80 TO STA. 191+00

NOTE: PIPE UNDERDRAINS SHALL BE INSTALLED ACCORDING TO SECTION 601 OF THE SSRBC AND STANDARD 601001-05. TOP OF PIPE UNDERDRAINS SHALL BE PLACED MINIMUM 6" BELOW THE AGGREGATE SUBGRADE IMPROVEMENT LAYER. THE COST OF MAKING PIPE UNDERDRAINS CONNECTIONS TO DRAINAGE STRUCTURES SHALL BE INCLUDED IN THE COST OF THE PIPE UNDERDRAINS.

MODEL: Default
 FILE: I:\MISC\proj\supp\mms-pw\benfey\comp\mms-pw\01\Documents\01 - DDOT Phase II Variable Drainage Detail\13233-shr-typrkcl-180.dgn
 461 N. JACKSON BLVD, SUITE 600, CHICAGO, IL 60611, P.312-467-0900 F.312-467-0905



USER NAME = rmartin	DESIGNED - RM/RMV	REVISED -
PLOT SCALE = 2,0000' / in.	DRAWN - RM/RMV	REVISED -
PLOT DATE = 2/2/2022	CHECKED - MPV	REVISED -
	DATE - 07/07/2021	REVISED -

**STATE OF ILLINOIS
DEPARTMENT OF TRANSPORTATION**

**I-80 TYPICAL SECTIONS
WOLF ROAD BRIDGE OVER I-80**

SCALE: SHEET OF SHEETS STA. TO STA.

F.A.P. RTE. 2688	SECTION 2020-250-BY	COUNTY WILL	TOTAL SHEETS 133	SHEET NO. 10
CONTRACT NO. 62N20				
ILLINOIS FED. AID PROJECT				

PROP. CURVE 1
 PI STA. = 12+46.67
 $\Delta = 8^\circ 20' 58''$ (RT)
 $D = 60^\circ 18' 41''$
 $R = 95.00'$
 $T = 6.93'$
 $L = 13.84'$
 $E = 0.25'$
 $e =$
 $T.R. =$
 $S.E. RUN =$
 $P.C. STA. = 12+39.74$
 $P.T. STA. = 12+53.58$

PROP. CURVE 2
 PI STA. = 16+89.82
 $\Delta = 2^\circ 08' 18''$ (RT)
 $D = 60^\circ 18' 41''$
 $R = 95.00'$
 $T = 1.77'$
 $L = 3.55'$
 $E = 0.02'$
 $e =$
 $T.R. =$
 $S.E. RUN =$
 $P.C. STA. = 16+88.04$
 $P.T. STA. = 16+91.59$

PROP. CURVE 3
 PI STA. = 21+92.59
 $\Delta = 2^\circ 30' 59''$ (RT)
 $D = 60^\circ 18' 41''$
 $R = 95.00'$
 $T = 2.09'$
 $L = 4.17'$
 $E = 0.02'$
 $e =$
 $T.R. =$
 $S.E. RUN =$
 $P.C. STA. = 21+90.50$
 $P.T. STA. = 21+94.67$

PROP. CURVE 4
 PI STA. = 28+34.67
 $\Delta = 14^\circ 59' 15''$ (LT)
 $D = 54^\circ 34' 03''$
 $R = 105.00'$
 $T = 13.81'$
 $L = 27.47'$
 $E = 0.90'$
 $e =$
 $T.R. =$
 $S.E. RUN =$
 $P.C. STA. = 28+20.86$
 $P.T. STA. = 28+48.33$

PROP. CURVE 5
 PI STA. = 29+50.12
 $\Delta = 14^\circ 22' 23''$ (RT)
 $D = 56^\circ 01' 44''$
 $R = 102.26'$
 $T = 12.89'$
 $L = 25.65'$
 $E = 0.81'$
 $e =$
 $T.R. =$
 $S.E. RUN =$
 $P.C. STA. = 29+37.23$
 $P.T. STA. = 29+62.88$

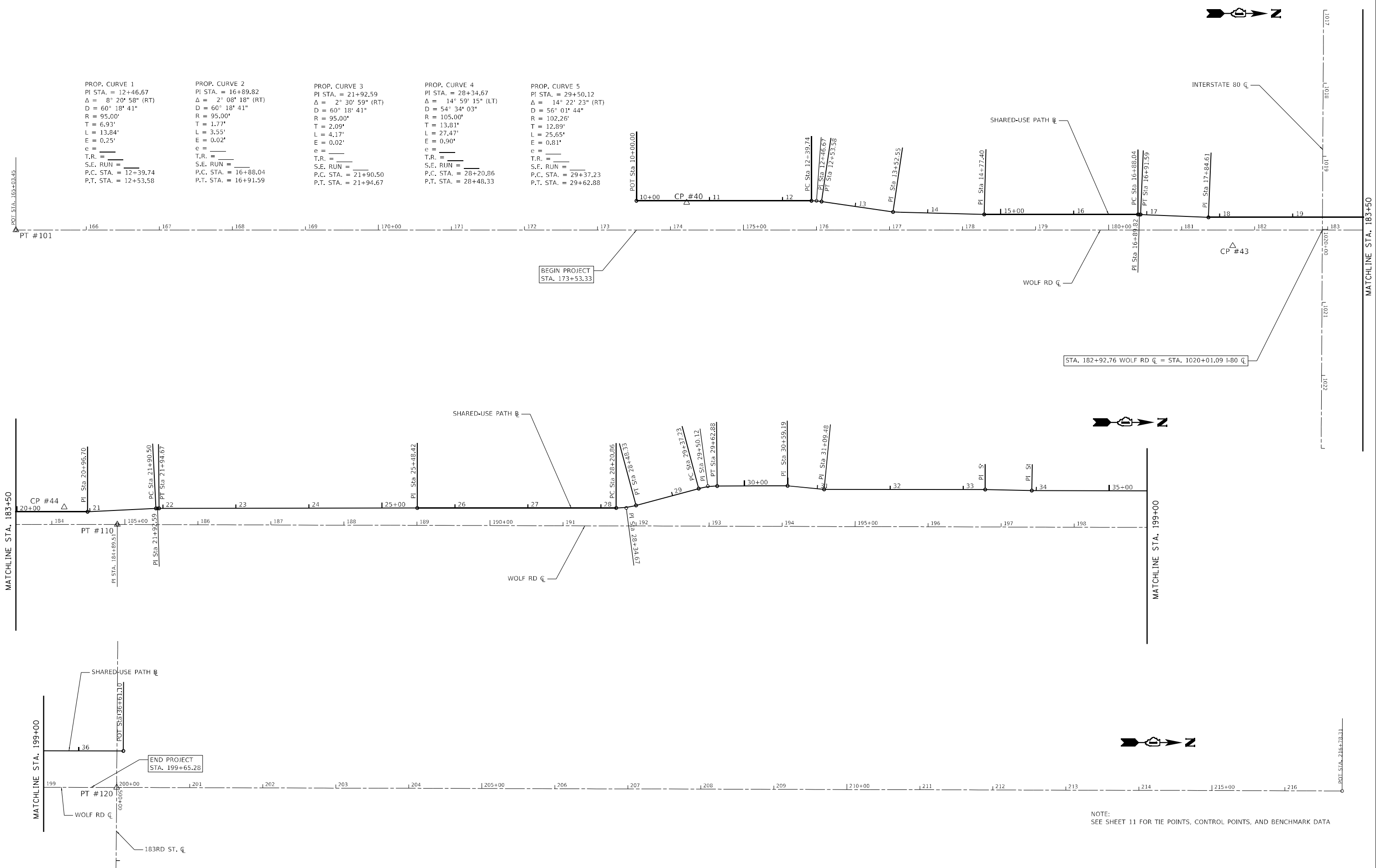

STA. 182+92.76 WOLF RD ζ = STA. 1020+01.09 I-80 ζ

END PROJECT
 STA. 199+65.28

NOTE:
 SEE SHEET 11 FOR TIE POINTS, CONTROL POINTS, AND BENCHMARK DATA

MODEL: D:\default...
 FILE: I:\M&E...
 PROJECT: I:\Projects\2020\20200425.00 - IDOT Phase II Wolf Road over I-80\Drawings\Current...
 DRAWING: I:\Projects\2020\20200425.00 - IDOT Phase II Wolf Road over I-80\Drawings\Current...
 SHEET: I:\Projects\2020\20200425.00 - IDOT Phase II Wolf Road over I-80\Drawings\Current...



USER NAME = rmartin	DESIGNED - RM/RMV	REVISED -
DRAWN - RM/RMV	REVISED -	
PLOT SCALE = 1/20,0109' / in.	CHECKED - MPV	REVISED -
PLOT DATE = 2/2/2022	DATE - 07/07/2021	REVISED -

**STATE OF ILLINOIS
 DEPARTMENT OF TRANSPORTATION**

ALIGNMENT SHEET			
WOLF ROAD BRIDGE OVER I-80			
SCALE: 1" = 50'	SHEET	OF	SHEETS
STA.			TO STA.

F.A.P. RTE.	SECTION	COUNTY	TOTAL SHEETS	SHEET NO.
2688	2020-250-BY	WILL	133	11
CONTRACT NO. 62N20				
ILLINOIS FED. AID PROJECT				

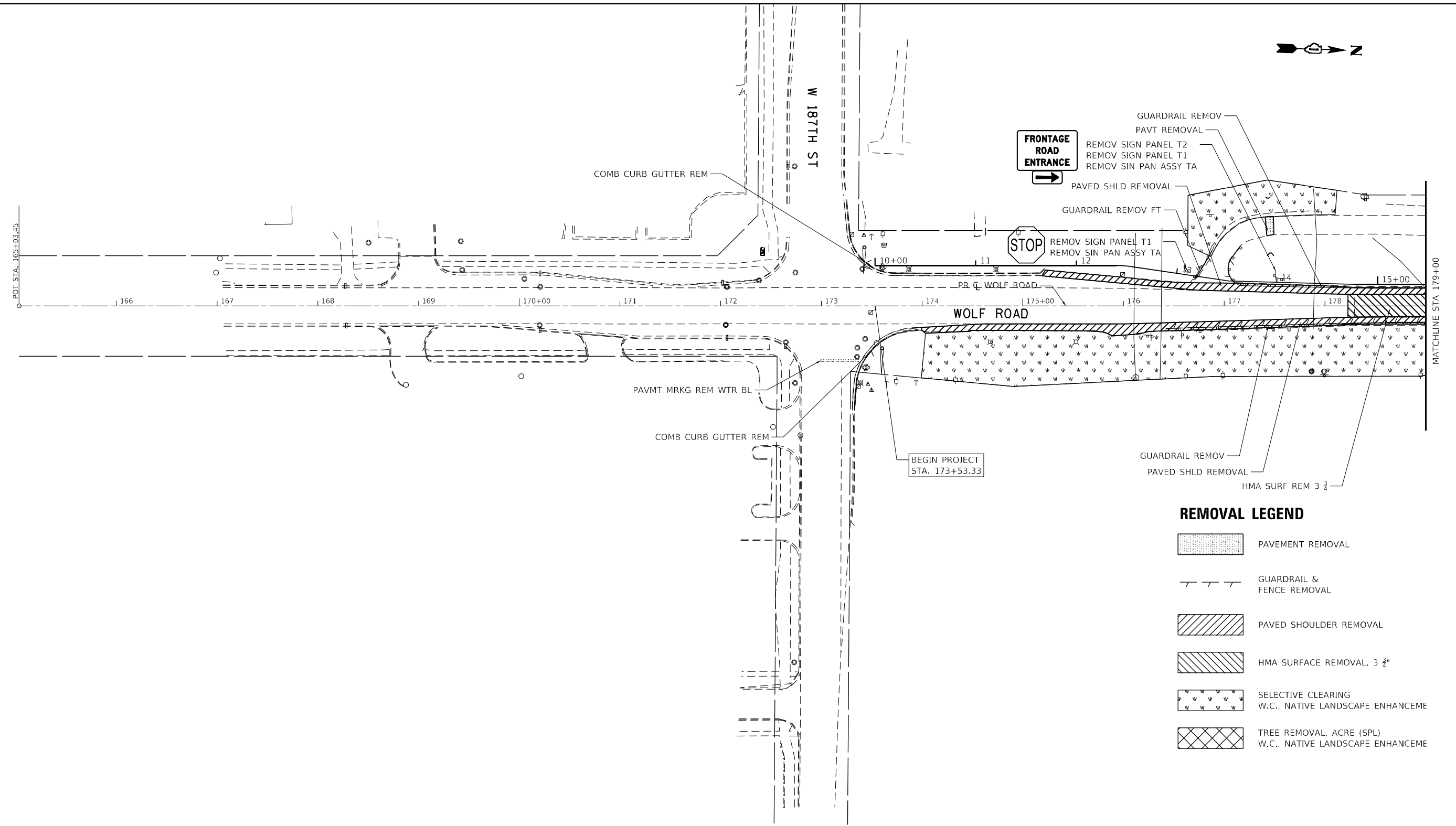

REMOVAL LEGEND

	PAVEMENT REMOVAL
	GUARDRAIL & FENCE REMOVAL
	PAVED SHOULDER REMOVAL
	HMA SURFACE REMOVAL, 3 3/4"
	SELECTIVE CLEARING W.C., NATIVE LANDSCAPE ENHANCEMENT
	TREE REMOVAL, ACRE (SPL) W.C., NATIVE LANDSCAPE ENHANCEMENT

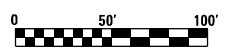

MODEL: Default
 FILE: \\MAILSrv\pub\primera\proj\bea\bea\proj\Documents\01\Projects\2020\2020\25\00 - DDOT Phase II Wolf Road over I-80\Drawings\Current Drawing Files\CADD_Sheets\Roadway\01\2323-sub-removal.dgn
 461 N. JACKSON BLVD, SUITE 600, CHICAGO, IL 60611, P.312-467-4000 F.312-467-4005

USER NAME = rmartin	DESIGNED - RM/RMV	REVISED -
DRAWN - RM/RMV	REVISIONS	REVISED -
PLOT SCALE = 100,0000' / in.	CHECKED - MPV	REVISED -
PLOT DATE = 2/2/2022	DATE - 07/07/2021	REVISED -



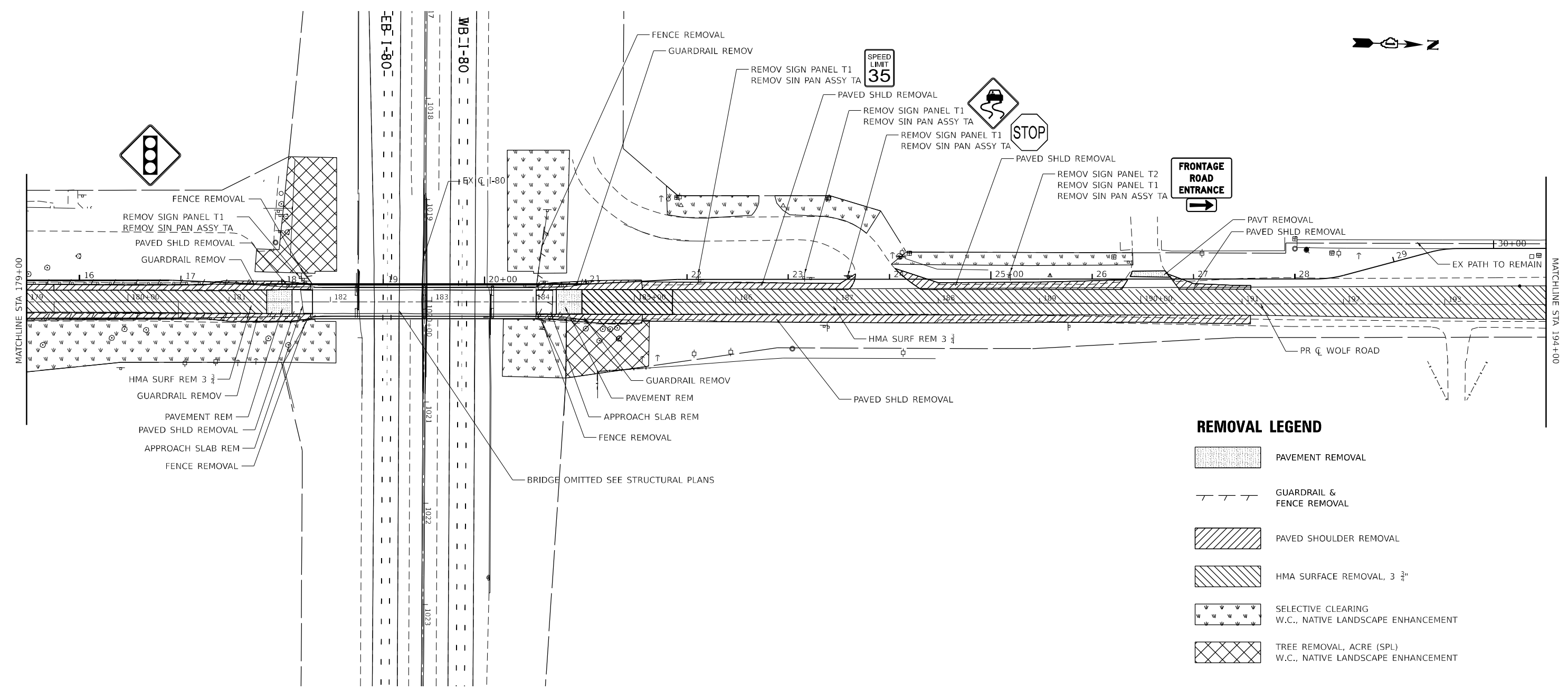

**STATE OF ILLINOIS
DEPARTMENT OF TRANSPORTATION**

REMOVAL PLAN				
WOLF ROAD BRIDGE OVER I-80				
SCALE:	SHEET	OF	SHEETS	STA. TO STA.

F.A.P. RTE. 2688	SECTION 2020-250-BY	COUNTY WILL	TOTAL SHEETS 133	SHEET NO. 13
CONTRACT NO. 62N20				
ILLINOIS FED. AID PROJECT				

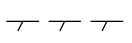

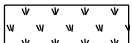
REMOVAL LEGEND

	PAVEMENT REMOVAL
	GUARDRAIL & FENCE REMOVAL
	PAVED SHOULDER REMOVAL
	HMA SURFACE REMOVAL, 3 3/4"
	SELECTIVE CLEARING W.C., NATIVE LANDSCAPE ENHANCEMENT
	TREE REMOVAL, ACRE (SPL) W.C., NATIVE LANDSCAPE ENHANCEMENT

MODEL: Default
 FILE: \\nautilus.primera.com\primera\proj\621\Documents\01\Project\2020\2500-1\DOT Phase II\Verbus Designer\2020\2500-1\MO 1-3 - Wolf Road over I-80\Drawings\Current\Drawing Files\CADD_Sheets\Radius\011223-2-rt-removal.dwg
 I:\DOT Phase II\Verbus Designer\2020\2500-1\DOT Phase II\Verbus Designer\2020\2500-1\MO 1-3 - Wolf Road over I-80\Drawings\Current\Drawing Files\CADD_Sheets\Radius\011223-2-rt-removal.dwg



USER NAME = rvandermus	DESIGNED - RM/RMV	REVISED -
DRAWN - RM/RMV	REVISIONS -	
PLOT SCALE = 100,0000' / in.	CHECKED - MPV	REVISED -
PLOT DATE = 3/11/2022	DATE - 07/07/2021	REVISED -

**STATE OF ILLINOIS
DEPARTMENT OF TRANSPORTATION**



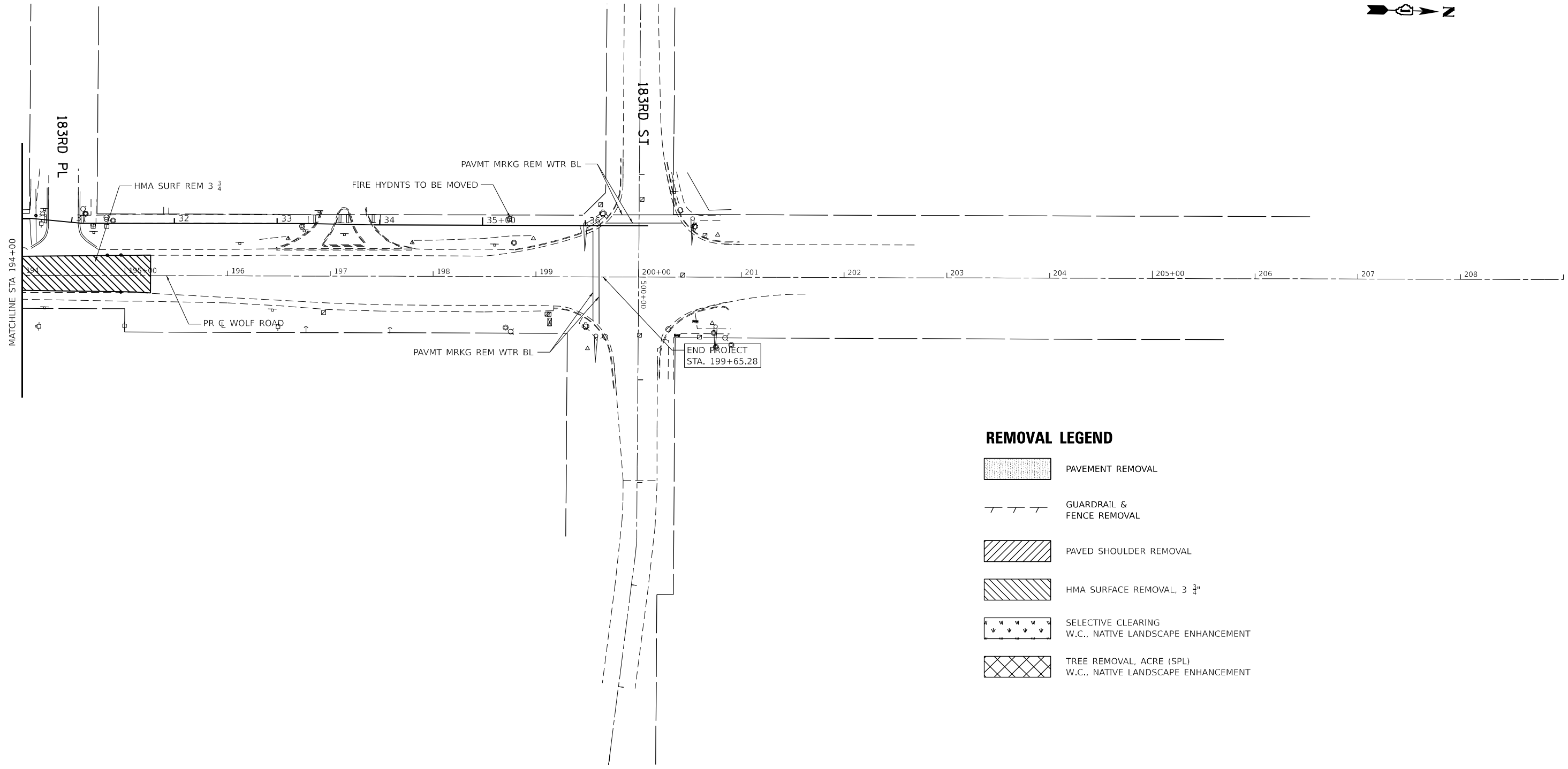

**REMOVAL PLAN
WOLF ROAD BRIDGE OVER I-80**

SCALE: SHEET OF SHEETS STA. TO STA.

F.A.I. RTE.	SECTION	COUNTY	TOTAL SHEETS	SHEET NO.
I-80	2020-250-BY	WILL	133	14
CONTRACT NO. 62N20			ILLINOIS FED. AID PROJECT	

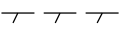

REMOVAL LEGEND

-  PAVEMENT REMOVAL
-  GUARDRAIL & FENCE REMOVAL
-  PAVED SHOULDER REMOVAL
-  HMA SURFACE REMOVAL, 3 3/4"
-  SELECTIVE CLEARING W.C., NATIVE LANDSCAPE ENHANCEMENT
-  TREE REMOVAL, ACRE (SPL) W.C., NATIVE LANDSCAPE ENHANCEMENT

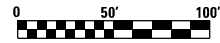

MODEL: Default
 FILE: \\naulc...primera.com\primera-ops\01\Documents\01_Projects\2020\2020-250-..._DOT_Phase II_Verbose_Design\2020\250.01_Wolf_Road..._MO_1-3...Wolf_Road...over_I-80\Drawings\Current_Drawing_Files\CADD_Sheets\Revised\011223-rlt-removal-03.dgn

	USER NAME = rvandermus	DESIGNED - RM/RMV	REVISED -
	PLOT SCALE = 100,0000' / in.	DRAWN - RM/RMV	REVISED -
	PLOT DATE = 3/16/2022	CHECKED - MPV	REVISED -
		DATE - 07/07/2021	REVISED -

STATE OF ILLINOIS
DEPARTMENT OF TRANSPORTATION

REMOVAL PLAN
WOLF ROAD BRIDGE OVER I-80

SCALE: SHEET OF SHEETS STA. TO STA.

F.A.I. RTE.	SECTION	COUNTY	TOTAL SHEETS	SHEET NO.
I-80	2020-250-BY	WILL	133	15
CONTRACT NO. 62N20				
ILLINOIS FED. AID PROJECT				

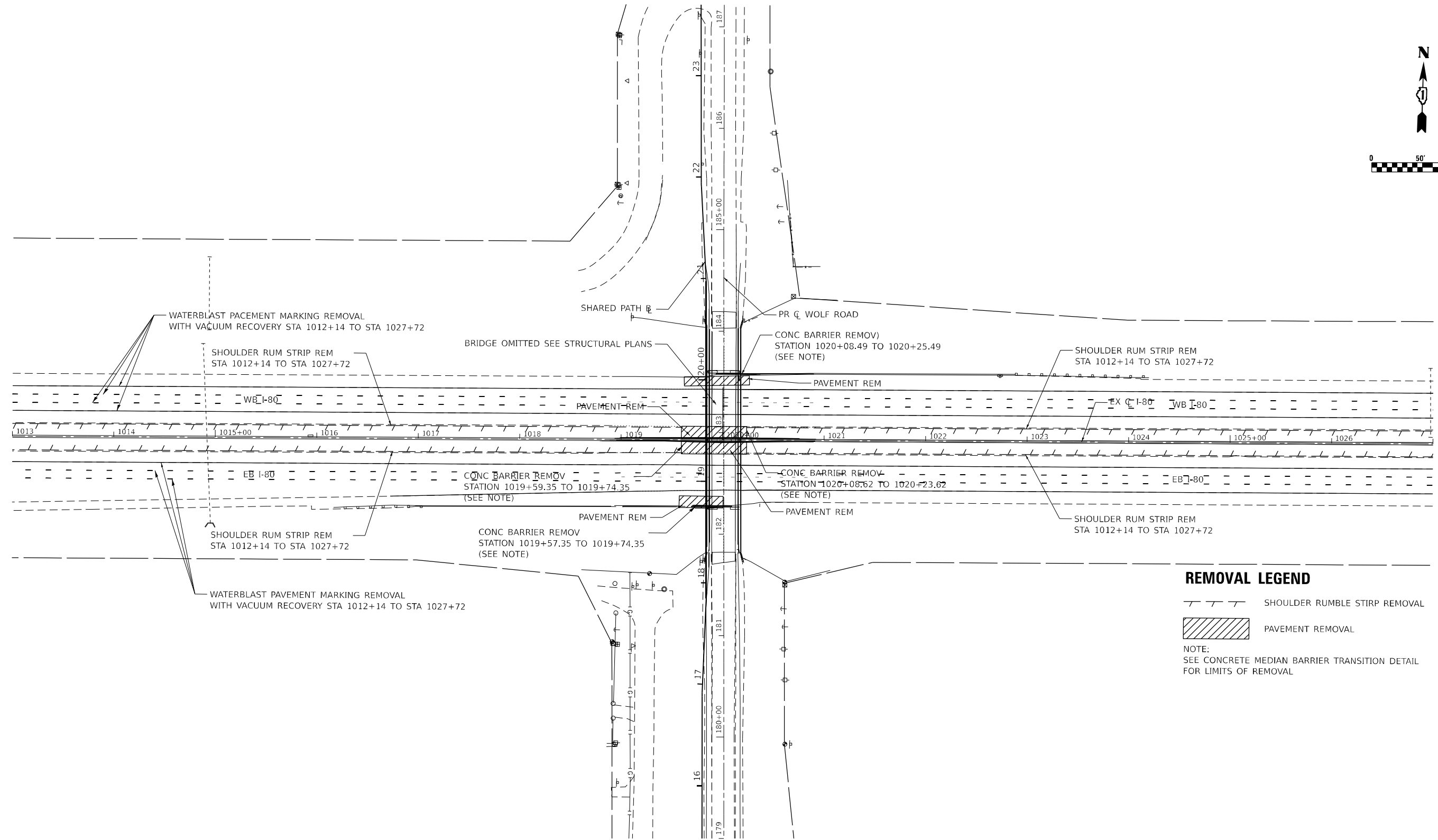
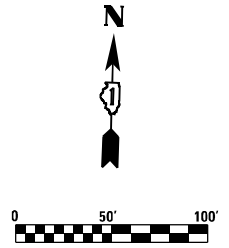

REMOVAL LEGEND

- SHOULDER RUMBLE STRIP REMOVAL
- PAVEMENT REMOVAL

NOTE:
SEE CONCRETE MEDIAN BARRIER TRANSITION DETAIL
FOR LIMITS OF REMOVAL

MODEL: Default
 FILE: \\MAILSrv\primera\p\k\best\p\comp\primera\proj\01\Documents\01\Project\2020\20200425\00 - IDOT Phase II Veribus Design\20200425\01 - WO L3 - Wolf Road over I-80 Drawings\Current Drawing File\CADD_Sheets\Radius\01122333-dt-l3-8b-removal.dwg
 461 W. JACKSON BLVD, SUITE 600, CHICAGO IL 60641, P.312-467-0911 F.312-467-0415



USER NAME = rvandermus	DESIGNED - RM/RMV	REVISED -
PLOT SCALE = 100,0000' / in.	DRAWN - RM/RMV	REVISED -
PLOT DATE = 2/4/2022	CHECKED - MPV	REVISED -
	DATE - 07/07/2021	REVISED -

**STATE OF ILLINOIS
DEPARTMENT OF TRANSPORTATION**

**I-80 REMOVAL PLAN
WOLF ROAD BRIDGE OVER I-80**

SCALE: SHEET OF SHEETS STA. TO STA.

F.A.P. RTE. 2688	SECTION 2020-250-BY	COUNTY WILL	TOTAL SHEETS 133	SHEET NO. 16
CONTRACT NO. 62N20			ILLINOIS FED. AID PROJECT	

PLAN	SURVEYED	DATE
	PLOTTED	
	ALIGNED	
	CHECKED	
	NO. _____	
	FILE NAME	

PROFILE	SURVEYED	DATE
	PLOTTED	
	GRADES	
	CHECKED	
	NO. _____	
	FILE NAME	

MODEL: Default
 FILE NAME: p:\projects\2020\202000425\00 - I-80 Phase II Vertical Design\202000425\01 - WO 1-3 - Wolf Road over I-80 Drawings\Current Drawing Files\CADD_Sheets\ roadway\01133333-11\plan\01.dwg
 PROJECTS\2020\202000425\00 - I-80 Phase II Vertical Design\202000425\01 - WO 1-3 - Wolf Road over I-80 Drawings\Current Drawing Files\CADD_Sheets\ roadway\01133333-11\plan\01.dwg

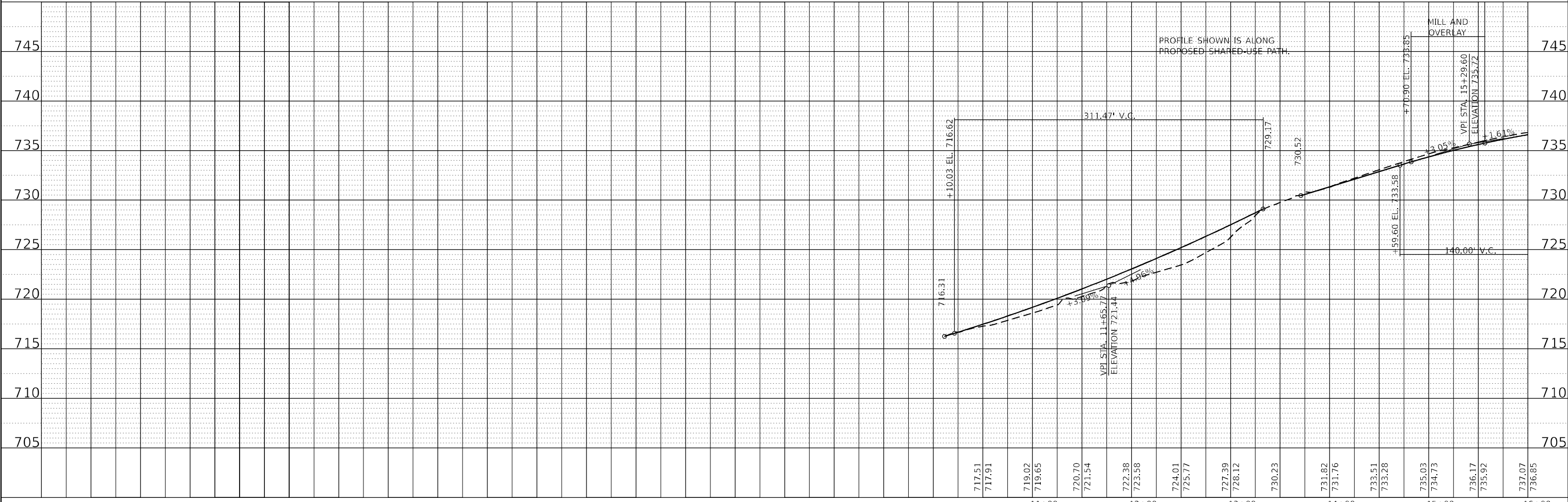
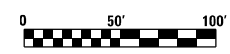
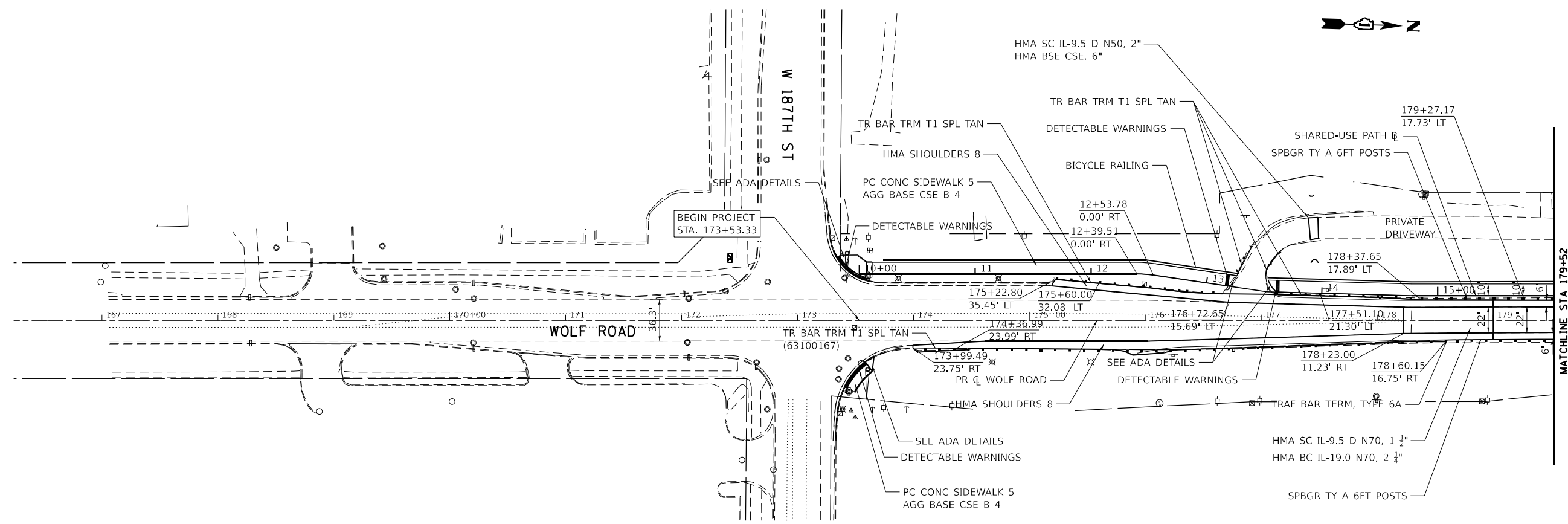

	USER NAME = rmandemus	DESIGNED - RM/RMV	REVISED -	STATE OF ILLINOIS DEPARTMENT OF TRANSPORTATION	SHARED USE PATH - PLAN & PROFILE WOLF ROAD BRIDGE OVER I-80		F.A.I. R.T.E.	SECTION	COUNTY	TOTAL SHEETS	SHEET NO.
	PLOT SCALE = 100,0000' / in.	CHECKED - MPV	REVISED -		SCALE:	SHEET	OF	SHEETS	STA.	TO	STA.
	PLOT DATE = 3/10/2022	DATE - 07/07/2021	REVISED -					2019-008-BR	WILL	133	17
										CONTRACT NO. 62N20	

DATE	
BY	
PLAN	SURVEYED
	NOTED
	ALIGNED
	CHECKED
	DATE
	FILE NAME
	NO.

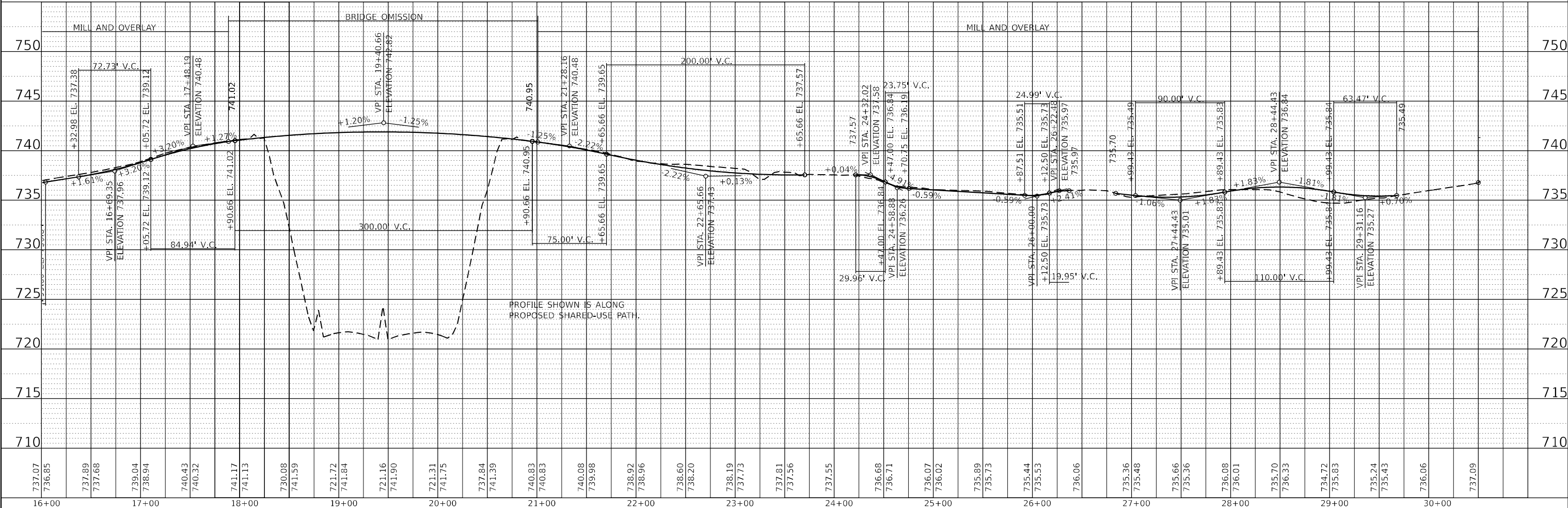
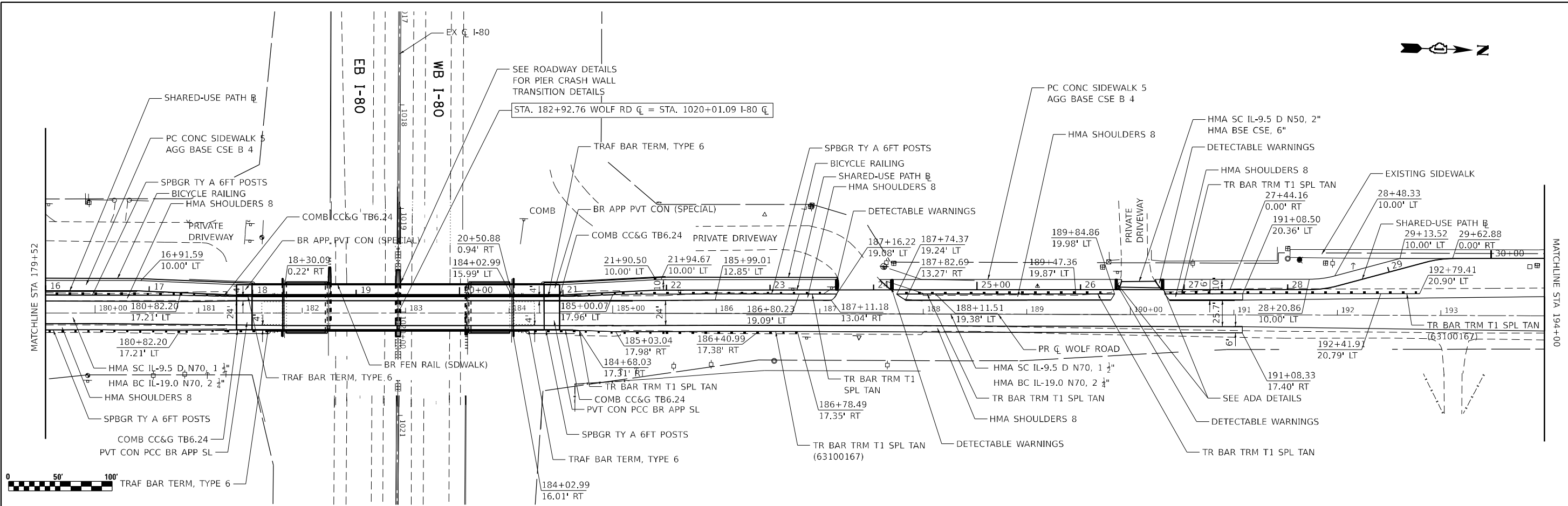

DATE	
BY	
PROFILE	SURVEYED
	NOTED
	ALIGNED
	CHECKED
	DATE
	FILE NAME
	NO.



USER NAME	= rvandermus
DESIGNED	- GSPRMV
DRAWN	- GSPRMV
CHECKED	- MPV
DATE	- 02/00/2029

REVISIONS	-
REVISIONS	-
REVISIONS	-
REVISIONS	-

**STATE OF ILLINOIS
DEPARTMENT OF TRANSPORTATION**

SHARED USE PATH - PLAN & PROFILE			
WOLF ROAD BRIDGE OVER I-80			
SCALE:	SHEET	OF SHEETS	STA. TO STA.

F.A.I. R.T.E.	SECTION	COUNTY	TOTAL SHEETS	SHEET NO.
I-80	2019-008-BR	WILL	133	18
CONTRACT NO. 62N20				
ILLINOIS FED. AID PROJECT				

PLAN	SURVEYED	BY	DATE
	PLOTTED		
	ALIGNMENT CHECKED		
	NOTE BOOK NO.		
	CADD FILE NAME		

PROFILE	SURVEYED	BY	DATE
	PLOTTED		
	GRADES CHECKED		
	NOTE BOOK NO.		
	STRUCTURE NOTATIONS C/PWD		

MODEL: Default
 FILE NAME: p:\primera\paweb\entirety\comp\in\m\p\p\0\Documents\01\Projects\2020\20200425\03 - IDOT Phase II Veribus Design\20200425\01_WO 1-3 - Wolf Road over I-80\Drawings\Current\Drawing Files\CADD_Sheets\ roadway\20113233-entirety\plan.dwg

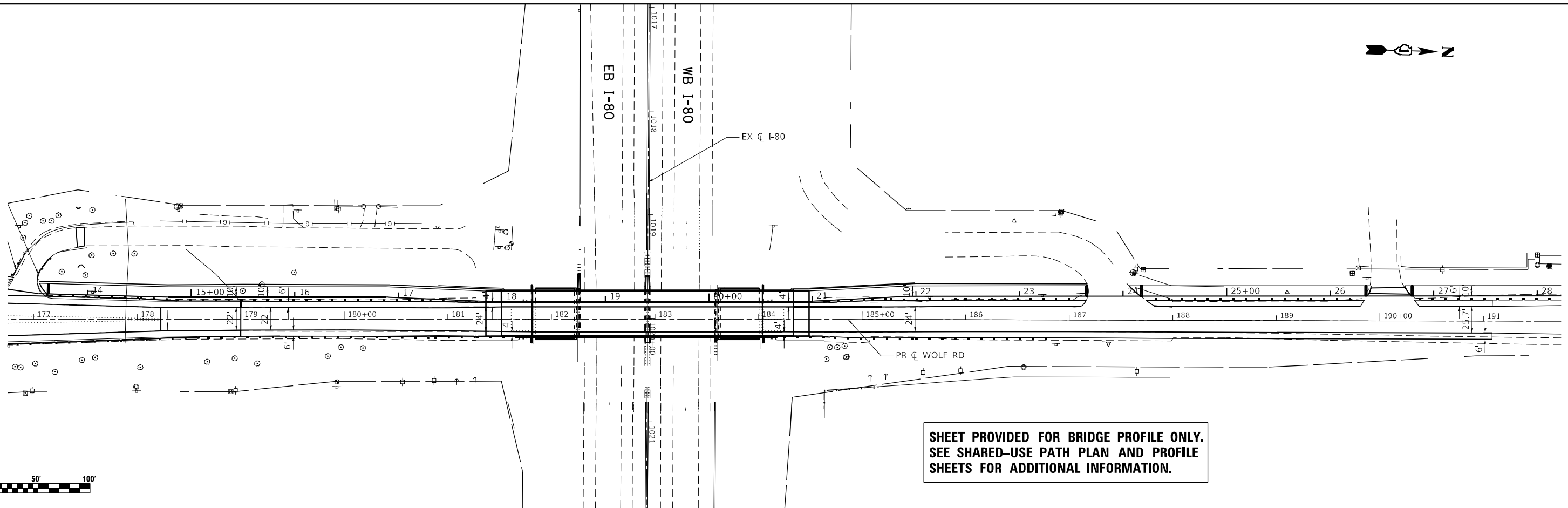

SHEET PROVIDED FOR BRIDGE PROFILE ONLY.
 SEE SHARED-USE PATH PLAN AND PROFILE SHEETS FOR ADDITIONAL INFORMATION.

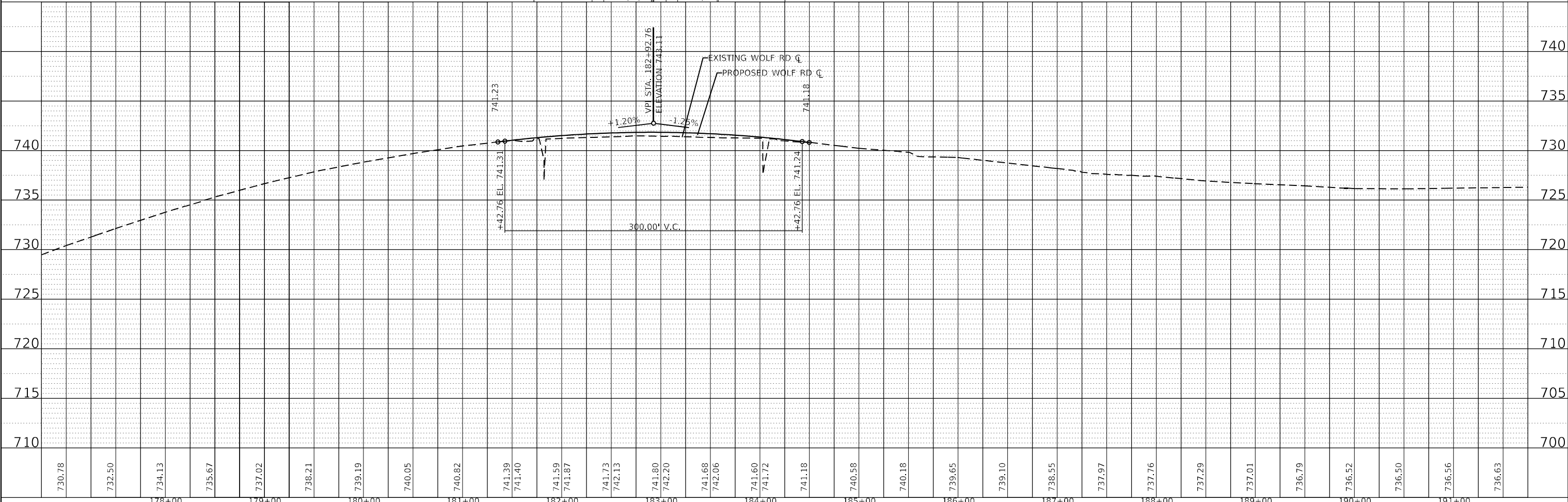

730.78	732.50	734.13	735.67	737.02	738.21	739.19	740.05	740.82	741.39	741.40	741.59	741.87	741.73	742.13	741.80	742.20	741.68	742.06	741.60	741.72	741.18	740.58	740.18	739.65	739.10	738.55	737.97	737.76	737.29	737.01	736.79	736.52	736.50	736.56	736.63		
178+00	179+00	180+00	181+00	182+00	183+00	184+00	185+00	186+00	187+00	188+00	189+00	190+00	191+00																								

661 N. JACKSON BLVD, SUITE 400, CHICAGO, IL 60611, P.312.465.4000 F.312.465.4000

USER NAME = rvandemus	DESIGNED - RM/RMV	REVISED -
	DRAWN - RM/RMV	REVISED -
PLOT SCALE = 100,0000' / in.	CHECKED - MPV	REVISED -
PLOT DATE = 2/2/2022	DATE - 07/07/2021	REVISED -

**STATE OF ILLINOIS
 DEPARTMENT OF TRANSPORTATION**

SN 099-0192 PLAN & PROFILE			
WOLF ROAD BRIDGE OVER I-80			
SCALE:	SHEET	OF SHEETS	STA. TO STA.

F.A.P. RTE.	SECTION	COUNTY	TOTAL SHEETS	SHEET NO.
	2019-008-BR	WILL	133	20
ILLINOIS FED. AID PROJECT			CONTRACT NO. 62N20	

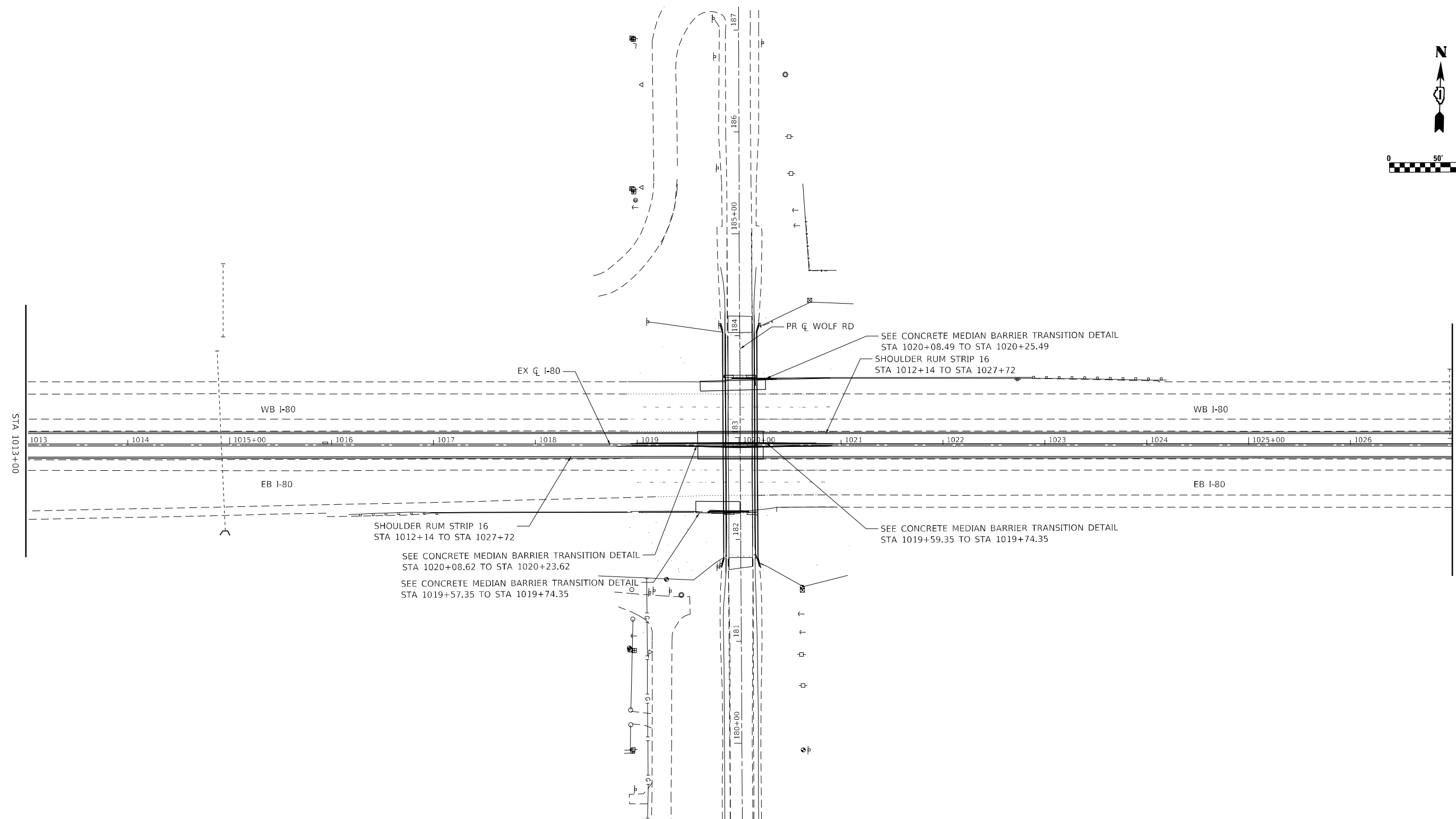
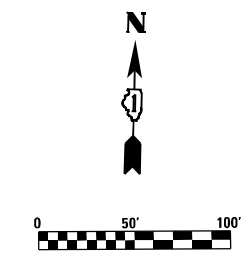

MODEL: Default
 FILE: \\MAILS\pub\primera\pk\benlley\comp\primera\proj\01\Documents\01 - Projects\2020\20200425.00 - IDOT Phase II Vertical Design\Drawings\01\20200425.01 - Wolf Road over I-80\Drawings\Current - Drawing Files\CADD_Sheets\Roadway\01\20200425.01.dgn
 401 N. JACKSON BLVD, SUITE 600, CHICAGO, IL 60611, P.312-467-4000 F.312-467-4005



USER NAME = rmartin	DESIGNED - RM/RMV	REVISED -
DRAWN - RM/RMV	REVISIONS	REVISED -
PLOT SCALE = 100,0000' / in.	CHECKED - MPV	REVISED -
PLOT DATE = 2/2/2022	DATE - 07/07/2021	REVISED -

STATE OF ILLINOIS
DEPARTMENT OF TRANSPORTATION

I-80 ROADWAY PLAN			
WOLF ROAD BRIDGE OVER I-80			
SCALE:	SHEET	OF SHEETS	STA. TO STA.

F.A.P. RTE.	SECTION	COUNTY	TOTAL SHEETS	SHEET NO.
2688	2020-250-BY	WILL	133	21
CONTRACT NO. 62N20				
ILLINOIS FED. AID PROJECT				

DETOUR NOTES

1. THE CONTRACTOR SHALL COORDINATE ALL DETOUR SIGNING WITH SIGNING IN PLACE FOR CONSTRUCTION ON ADJACENT PROJECTS.
2. THE DETOUR SIGNING SHALL BE IN ACCORDANCE WITH THE STANDARD AND AS DIRECTED BY THE ENGINEER.
3. THE CONTRACTOR SHALL BE RESPONSIBLE FOR THE LOCATION OF ALL DETOUR SIGNING. THE CONTRACTOR MAY REQUEST THAT THE ENGINEER VERIFY THE POSITION OF ANY SIGN.
4. ACTUAL LOCATION FOR SIGNING SHOWN ON THE DETOUR PLANS MAY BE ADJUSTED TO FIT FIELD CONDITIONS.
5. ALL EXISTING SIGNING THAT IS NOT APPLICABLE WHEN THE DETOUR IS IN EFFECT SHALL BE COVERED BY THE CONTRACTOR IN A MANNER MEETING THE APPROVAL OF THE ENGINEER. ALL DETOUR SIGNS INSTALLED ON ROADWAYS SHALL BE COVERED DURING HOURS THAT THE DETOUR IS NOT IN EFFECT.
6. THE CONTRACTOR SHALL NOTIFY THE ENGINEER OF THE PROPOSED ROADWAY CLOSURES 28 DAYS IN ADVANCE.
7. THE CONTRACTOR SHALL ERECT PORTABLE CHANGEABLE MESSAGE SIGNS ON ROADWAYS OR RAMP PROPOSED TO BE CLOSED 7 DAYS IN ADVANCE OF THE CLOSURE. THE MESSAGE TO BE AS SPECIFIED BY THE ENGINEER. CHANGEABLE MESSAGE SIGNS ARE TO BE INSTALLED IN EACH DIRECTION ALONG ROADWAYS PROPOSED TO BE CLOSED. CHANGEABLE MESSAGE SIGNS WILL BE INCLUDED IN THE COST OF THE DETOUR.
8. THE CONTRACTOR SHALL MAINTAIN ACCESS TO ALL DRIVEWAYS AT ALL TIMES.
9. ERECT SIGN ASSEMBLY 16 WITH START AND END DATE PANELS IN PLACE ON ROAD TO BE CLOSED IN EACH DIRECTION NEAR POINT OF CLOSURE OR WITHIN SECTION TO BE FULLY CLOSED TWO (2) WEEKS PRIOR TO START DATE OF FULL CLOSURE. REMOVE ASSEMBLY AFTER CLOSURE.

MAINTENANCE OF TRAFFIC NOTES

1. THE CONTRACTOR SHALL REQUEST AND GAIN APPROVAL FROM THE ILLINOIS DEPARTMENT OF TRANSPORTATION'S EXPRESSWAY TRAFFIC OPERATIONS ENGINEER AT WWW.IDOTLCS.COM TWENTY-FOUR (24) HOURS IN ADVANCE OF ALL PERMANENT AND WEEKEND CLOSURES ON ALL FREEWAYS AND/OR EXPRESSWAYS IN DISTRICT ONE. THIS ADVANCE NOTIFICATION IS CALCULATED BASED ON A WORKWEEK OF MONDAY THROUGH FRIDAY AND SHALL NOT INCLUDE WEEKENDS OR HOLIDAYS.
- ADJUSTMENTS TO TRAFFIC SIGNAL TIMINGS AT 187TH AND 183RD SHALL BE PAID FOR AS TEMPORARY TRAFFIC SIGNAL TIMING.
- TEMPORARY CONCRETE BARRIER SHALL INCLUDE WALL REFLECTORS PER IDOT STANDARD TC-09. THE CONTRACTOR SHALL ALSO INSTALL WALL REFLECTORS ON EXISTING CRASHWALL BARRIERS WHERE TRAFFIC IS LESS THAN 2 FEET FROM THE BASE OF EXISTING BARRIER.

DETOUR OVERVIEW

ROAD	MOT STAGE	WORK ACTIVITY	MAXIMUM DETOUR DURATION
WOLF RD BRIDGE WOLF RD OVER I-80	1	BRIDGE DECK REMOVAL AND REPLACEMENT, SHARED-USE PATH INSTALLATION	6 MONTHS

EXISTING RAMP MOVEMENTS, AVERAGE DAILY TRAFFIC (ADT) AND PEAK HOUR VOLUME (PHV)

ROAD	ADT (2019)	PHV AM(PM) (2019)
WOLF RD BRIDGE WOLF RD OVER I-80	15,800	1,896 (1,612)

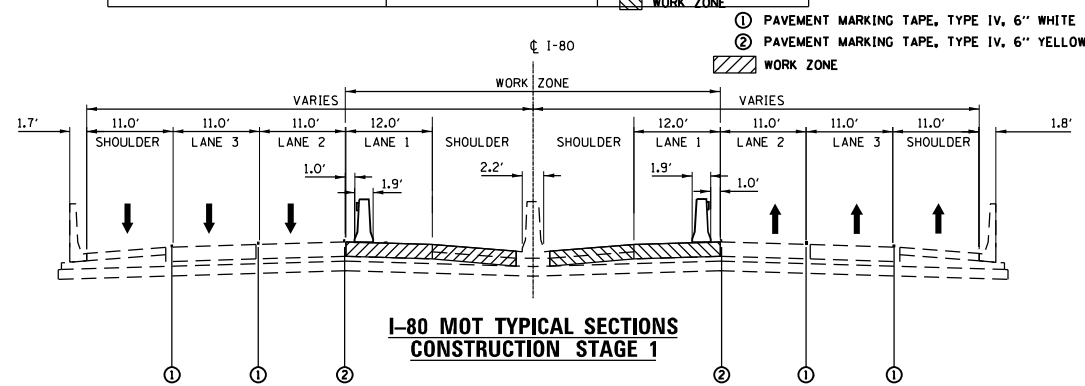

DETOUR SIGNS

① ROAD CLOSED TO THRU TRAFFIC
R11-4-6030 ON TYPE III BARRICADE

②g DETOUR
M4-10R-4818 ON TYPE III BARRICADE

②b DETOUR
M4-10L-4818 ON TYPE III BARRICADE

③ ROAD CLOSED AHEAD
W20-3(O)-48

③g DETOUR AHEAD
W20-2(O)-48

③b ROAD CLOSED 500'
W20-3(O)-48

④ END DETOUR
M4-8A-2418

⑤ NORTH M3-1(O)-3618
WOLF RD MX-X
DETOUR M4-9S-3024

⑥ NORTH M3-1(O)-3618
WOLF RD MX-X
DETOUR M4-9R-3024

⑦ NORTH M3-1(O)-3618
WOLF RD MX-X
DETOUR M4-9L-3024

⑧ NORTH M3-1(O)-3618
WOLF RD MX-X
DETOUR M4-9L-3024

⑨ NORTH M3-1(O)-3618
WOLF RD MX-X
DETOUR M4-9R-3024

⑩ SOUTH M3-1(O)-3618
WOLF RD MX-X (SEE NOTE 1)
DETOUR M4-9S-3024

⑪ SOUTH M3-1(O)-3618
WOLF RD MX-X
DETOUR M4-9R-3024

⑫ SOUTH M3-1(O)-3618
WOLF RD MX-X
DETOUR M4-9L-3024

⑬ SOUTH M3-1(O)-3618
WOLF RD MX-X
DETOUR M4-9L-3024

⑭ SOUTH M3-1(O)-3618
WOLF RD MX-X
DETOUR M4-9R-3024

⑮ WOLF RD CLOSED AHEAD FOLLOW DETOUR (SEE NOTE 1) MX-X

⑮c WOLF RD BRIDGE CLOSED AT I-80 FOLLOW DETOUR (SEE NOTE 1) MX-X

⑯ ROAD WILL BE CLOSED FROM MMM # THRU MMM

⑰ ROAD CLOSED ### MILES AHEAD LOCAL TRAFFIC ONLY (SEE NOTE 2)

NOTE 1: 6" UPPERCASE BLACK LETTERS ON ORANGE REFLECTIVE BACKGROUND
NOTE 2: 0.80 MILES FROM 179TH STREET. 0.70 FROM 191 STREET.

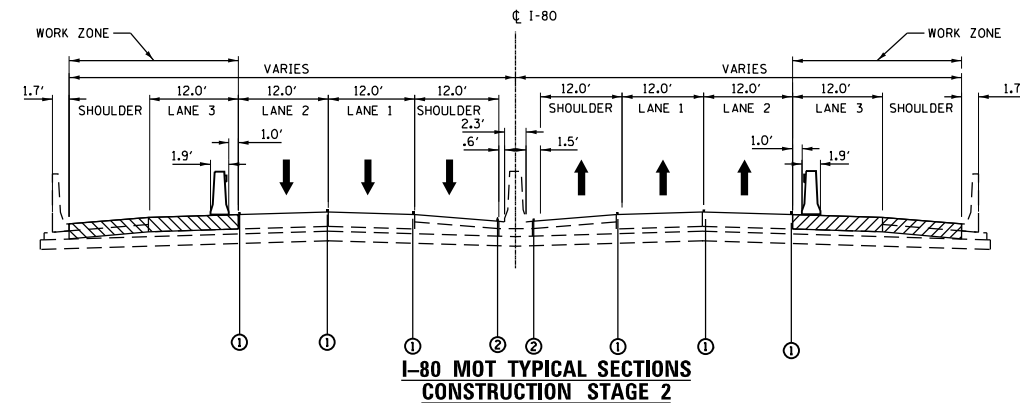

MODEL: Default
 FILE: I:\MTE_Plan\primera-nw-bentley.com\primera-nw\01\Documents\01\Project\2020\250_00_IDOT Phase II Vertical Designer\2020\250_01_Wolf Road over I-80\Drawings\Current\Drawing Files\CADD_Sheets\Roadway\01122131-plt-embgencross

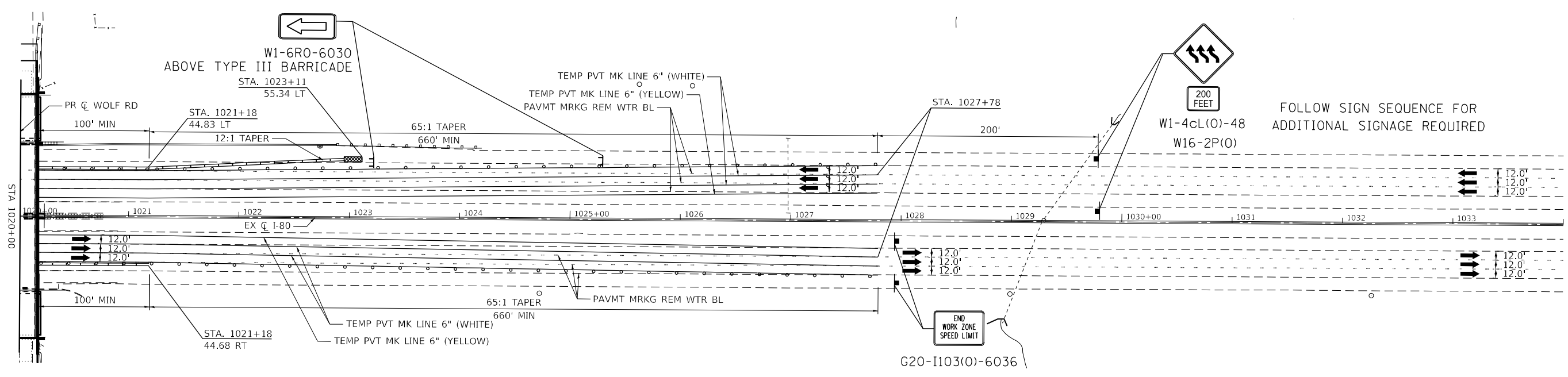
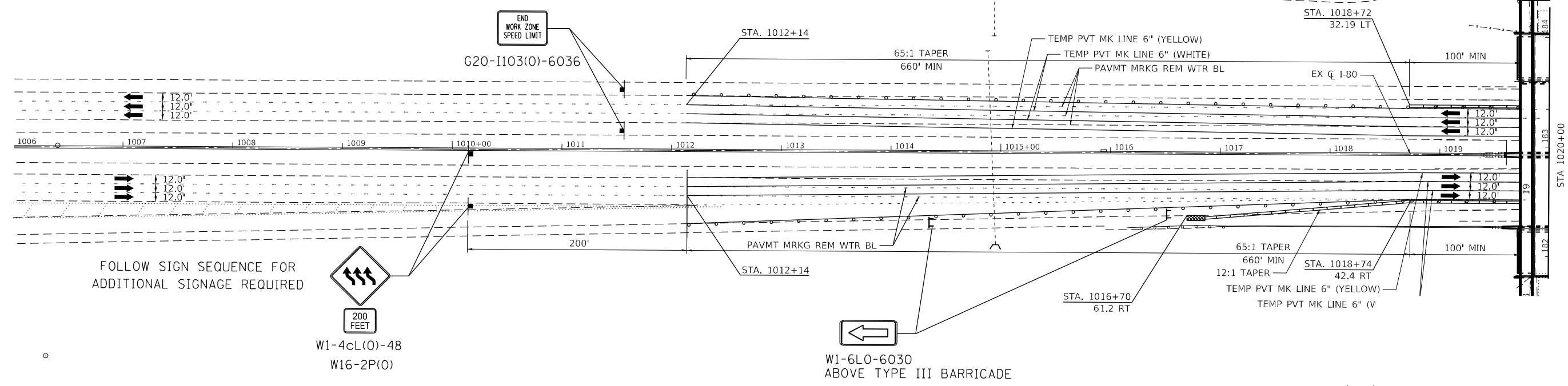
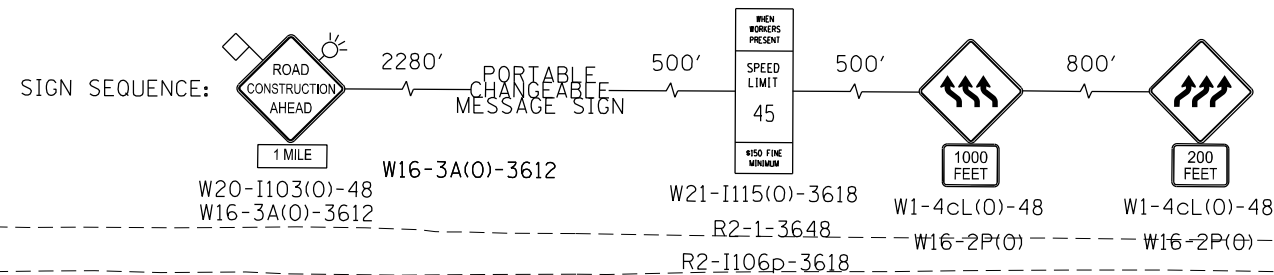

NOTE: WORK ZONE SIGN ARRAY SHALL FOLLOW IDOT DISTRICT 1 STANDARD TC-09

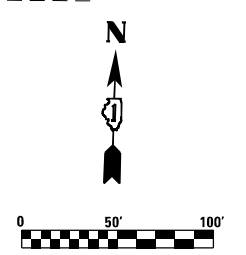

MODEL: Default
 FILE: \\nautilus.primera.com\primera\proj\01\Documents\01 - IDOT Phase II Variable Draft\m20200425_01_WO I-3 - Wolf Road over I-80\Drawings\Current Drawing Files\CADD_Sheets\Roadway\0113233-ehh-L-60-mot-02.dgn



USER NAME = rmarlin	DESIGNED - RM/RMV	REVISED -
PLOT SCALE = 100,0000' / in.	DRAWN - RM/RMV	REVISED -
PLOT DATE = 2/2/2022	CHECKED - MPV	REVISED -
	DATE - 07/07/2021	REVISED -

**STATE OF ILLINOIS
DEPARTMENT OF TRANSPORTATION**

I-80 TRAFFIC CONTROL STAGE 2 WOLF ROAD BRIDGE OVER I-80	
SCALE:	SHEET OF SHEETS STA. TO STA.

F.A.P. RTE. 2688	SECTION 2020-250-BY	COUNTY WILL	TOTAL SHEETS 133	SHEET NO. 24
CONTRACT NO. 62N20				
ILLINOIS FED. AID PROJECT				

MODEL: Default
 FILE: \\MAILS01\primera\pww\benjef\comp\primera\pww\01\Documents\01 - Project\2020\20200425\00 - IDOT Phase II Veribus Design\20200425\01 - WO 1-3 - Wolf Road over I-80\Drawings\Current\Drawing Files\CADD_Sheets\Radius\0112233-rt-1-80-act-03.dgn
 461 N. JACKSON BLVD, SUITE 600, CHICAGO, IL 60611, P.312-460-4000 F.312-460-4005

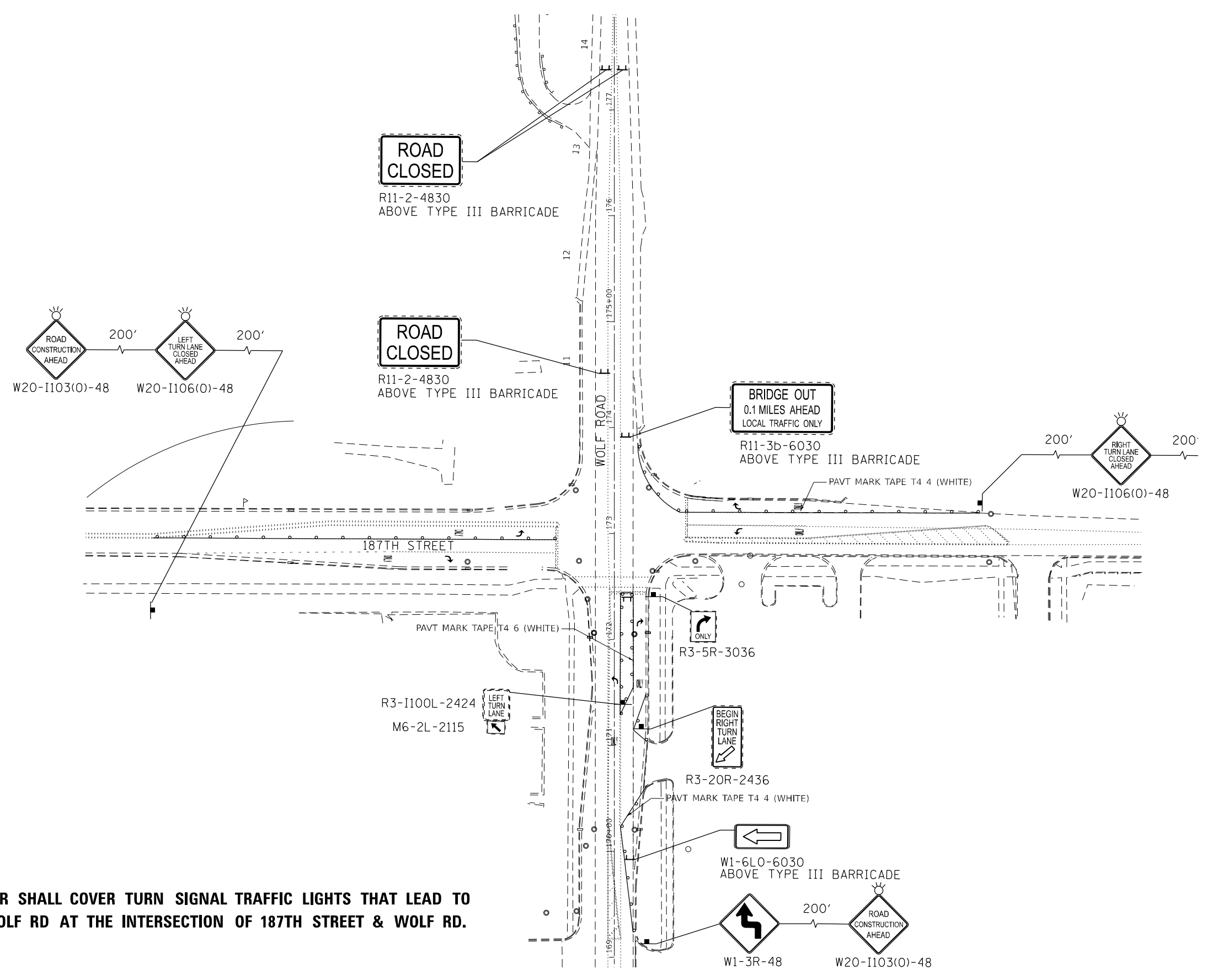

NOTE: CONTRACTOR SHALL COVER TURN SIGNAL TRAFFIC LIGHTS THAT LEAD TO NORTHBOUND WOLF RD AT THE INTERSECTION OF 187TH STREET & WOLF RD.

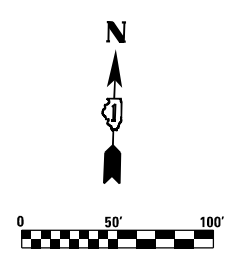

USER NAME = rvandermus	DESIGNED - RM/RMV	REVISED -
	DRAWN - RM/RMV	REVISED -
PLOT SCALE = 100,0000' / in.	CHECKED - MPV	REVISED -
PLOT DATE = 3/16/2022	DATE - 07/07/2021	REVISED -

**STATE OF ILLINOIS
DEPARTMENT OF TRANSPORTATION**

**187TH STREET TRAFFIC CONTROL
WOLF ROAD BRIDGE OVER I-80**

SCALE: SHEET OF SHEETS STA. TO STA.

F.A.I. RTE.	SECTION	COUNTY	TOTAL SHEETS	SHEET NO.
I-80	2020-250-BY	WILL	133	25
CONTRACT NO. 62N20				
ILLINOIS FED. AID PROJECT				

MODEL: Default
 FILE: \\nautilus.primera.com\primera\proj\62102020\0425\00 - IDOT Phase II Veribus Designer\20200425\01 - Wolf Road over I-80\Drawings\Current Drawing Files\CADD_Sheets\Roadway\01122323-rt-detour

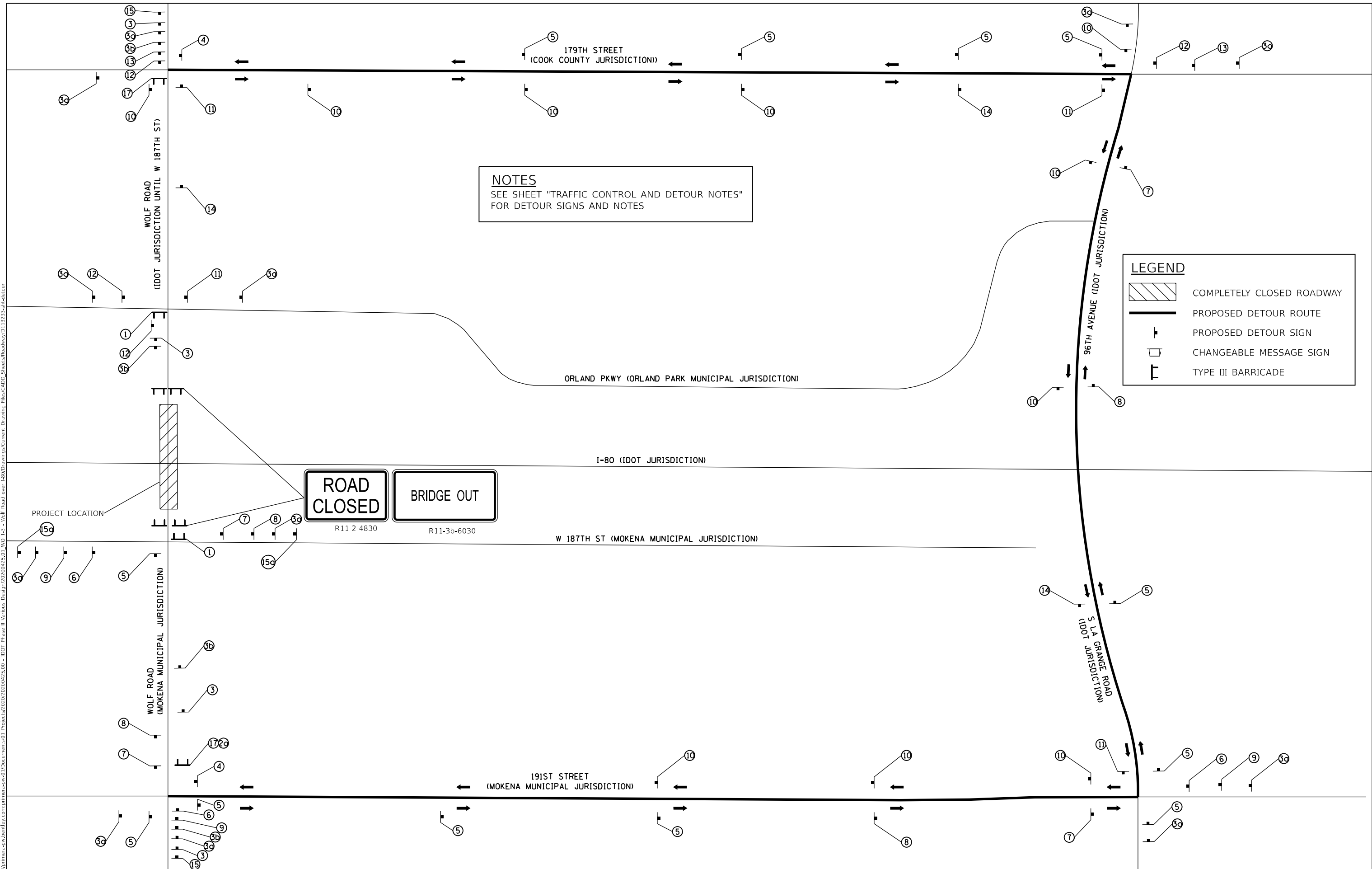

NOTES
 SEE SHEET "TRAFFIC CONTROL AND DETOUR NOTES" FOR DETOUR SIGNS AND NOTES

LEGEND

- COMPLETELY CLOSED ROADWAY
- PROPOSED DETOUR ROUTE
- PROPOSED DETOUR SIGN
- CHANGEABLE MESSAGE SIGN
- TYPE III BARRICADE

	USER NAME = rvandermus	DESIGNED - RM/RMV	REVISED -
	PLOT SCALE = 2,000' / in.	DRAWN - RM/RMV	REVISED -
	PLOT DATE = 3/10/2022	CHECKED - MPV	REVISED -
		DATE - 07/07/2021	REVISED -

STATE OF ILLINOIS
DEPARTMENT OF TRANSPORTATION

I-80 DETOUR PLANS
WOLF ROAD BRIDGE OVER I-80

SCALE: SHEET OF SHEETS STA. TO STA.

F.A.I. RTE.	SECTION	COUNTY	TOTAL SHEETS	SHEET NO.
I-80	2020-250-BY	WILL	133	26
ILLINOIS FED. AID PROJECT			CONTRACT NO. 62N20	

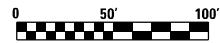
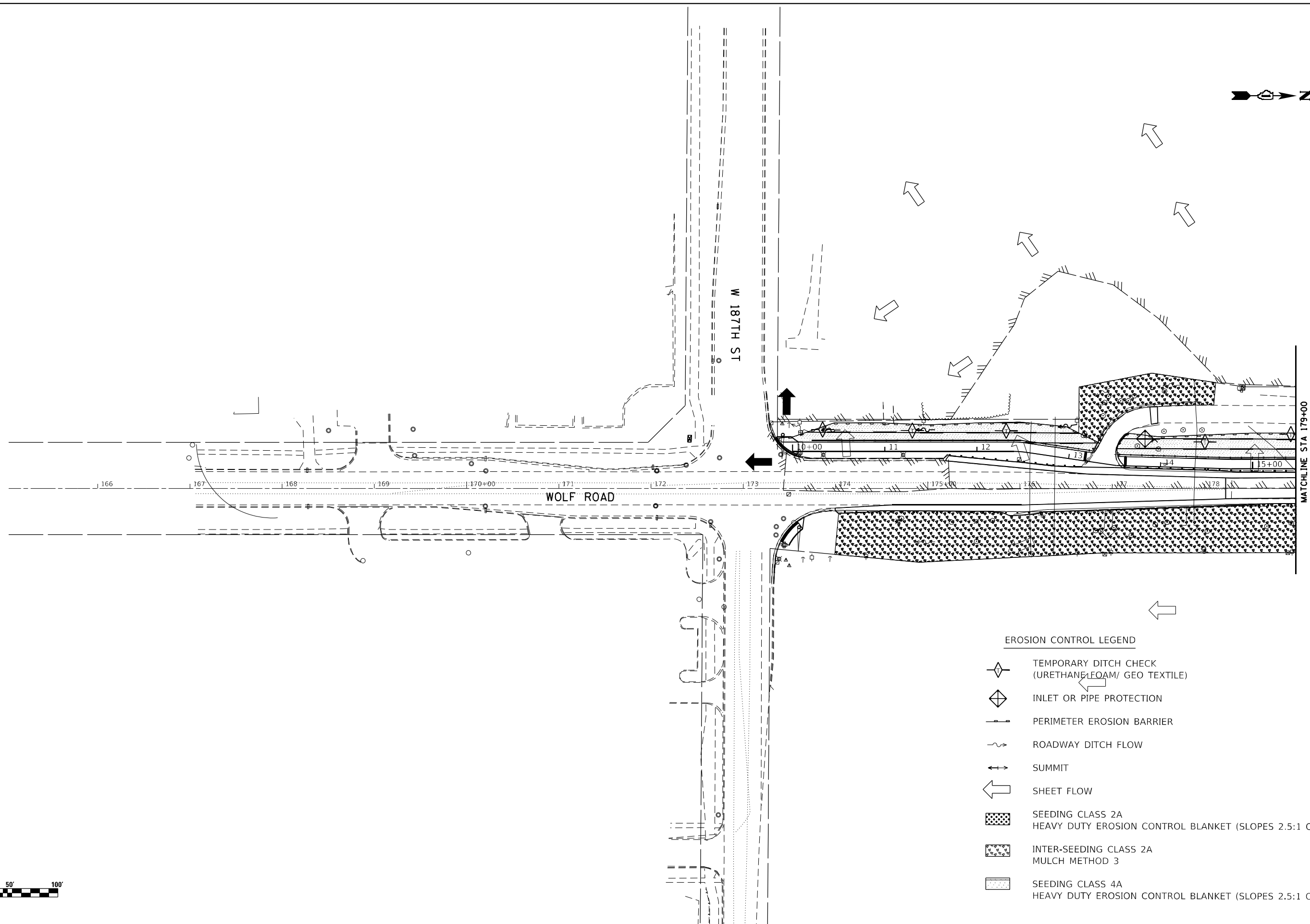

- EROSION CONTROL LEGEND**
- TEMPORARY DITCH CHECK (URETHANE LEQAM/ GEO TEXTILE)
 - INLET OR PIPE PROTECTION
 - PERIMETER EROSION BARRIER
 - ROADWAY DITCH FLOW
 - SUMMIT
 - SHEET FLOW
 - SEEDING CLASS 2A
HEAVY DUTY EROSION CONTROL BLANKET (SLOPES 2.5:1 OR GREATER)
 - INTER-SEEDING CLASS 2A
MULCH METHOD 3
 - SEEDING CLASS 4A
HEAVY DUTY EROSION CONTROL BLANKET (SLOPES 2.5:1 OR GREATER)

MODEL: D:\Full\...
 FILE: NAME: ...
 PROJECT: ...
 USER: ...
 DATE: ...



USER NAME = rmartin	DESIGNED - RM/RMV	REVISED -
DRAWN - RM/RMV	REVISED -	
PLOT SCALE = 100,0034' / in.	CHECKED - MPV	REVISED -
PLOT DATE = 2/2/2022	DATE - 07/07/2021	REVISED -

**STATE OF ILLINOIS
DEPARTMENT OF TRANSPORTATION**

**EROSION CONTROL PLAN
WOLF ROAD BRIDGE OVER I-80**

SCALE: SHEET OF SHEETS STA. TO STA.

F.A.P. RTE. 2688	SECTION 2020-250-BY	COUNTY WILL	TOTAL SHEETS 133	SHEET NO. 27
CONTRACT NO. 62N20				
ILLINOIS FED. AID PROJECT				

MODEL: D:\Full\...
 FILE NAME: ...
 441 W. JACKSON BLVD, SUITE 610, CHICAGO, IL 60641, P. 312-467-4900, F. 312-467-4915

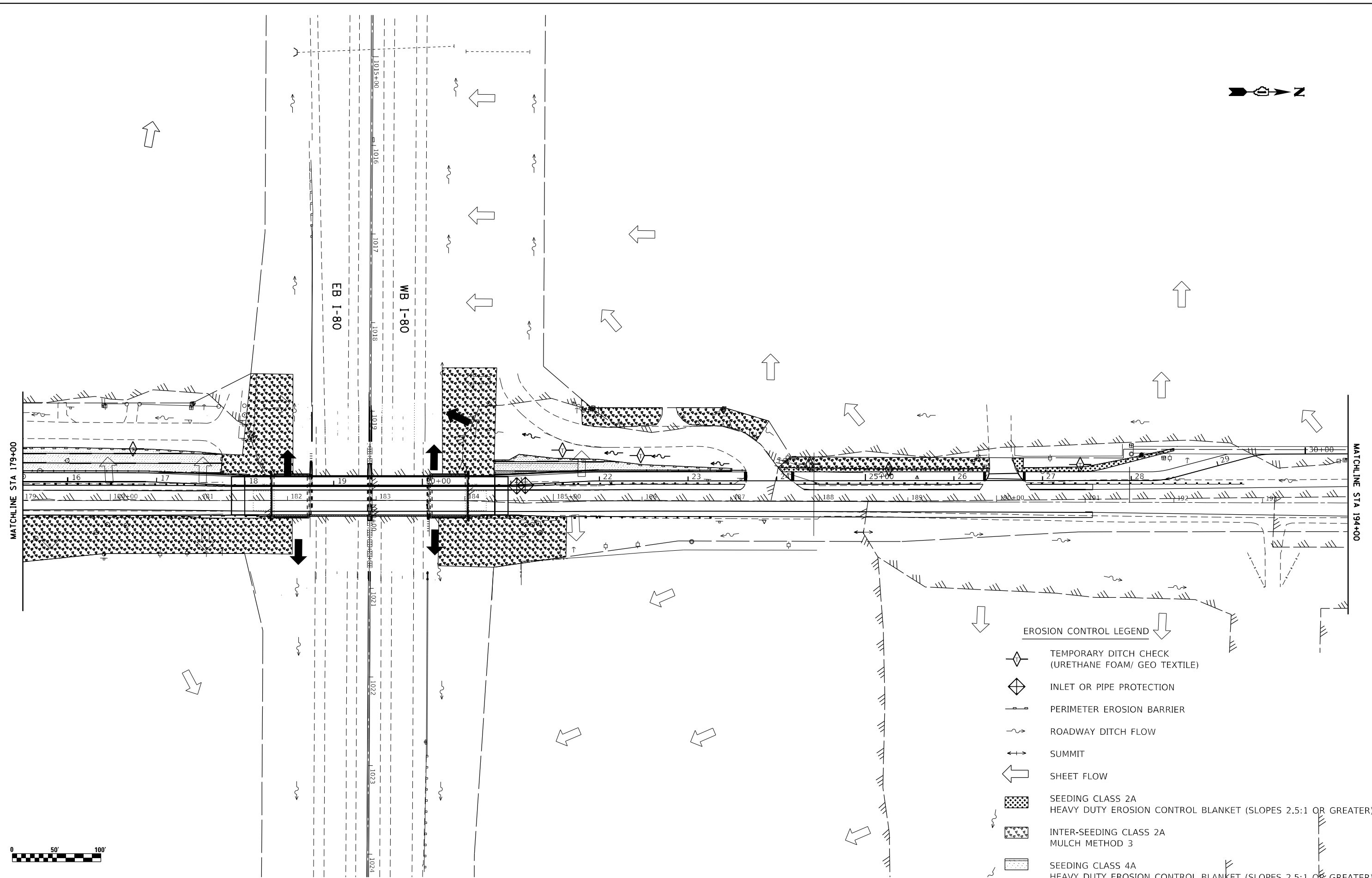

- EROSION CONTROL LEGEND**
- TEMPORARY DITCH CHECK (URETHANE FOAM/ GEO TEXTILE)
 - INLET OR PIPE PROTECTION
 - PERIMETER EROSION BARRIER
 - ROADWAY DITCH FLOW
 - SUMMIT
 - SHEET FLOW
 - SEEDING CLASS 2A
 - HEAVY DUTY EROSION CONTROL BLANKET (SLOPES 2.5:1 OR GREATER)
 - INTER-SEEDING CLASS 2A
 - MULCH METHOD 3
 - SEEDING CLASS 4A
 - HEAVY DUTY EROSION CONTROL BLANKET (SLOPES 2.5:1 OR GREATER)



USER NAME = rmartin	DESIGNED - RM/RMV	REVISED -
	DRAWN - RM/RMV	REVISED -
PLOT SCALE = 100.0034' / in.	CHECKED - MPV	REVISED -
PLOT DATE = 2/2/2022	DATE - 07/07/2021	REVISED -

STATE OF ILLINOIS
DEPARTMENT OF TRANSPORTATION







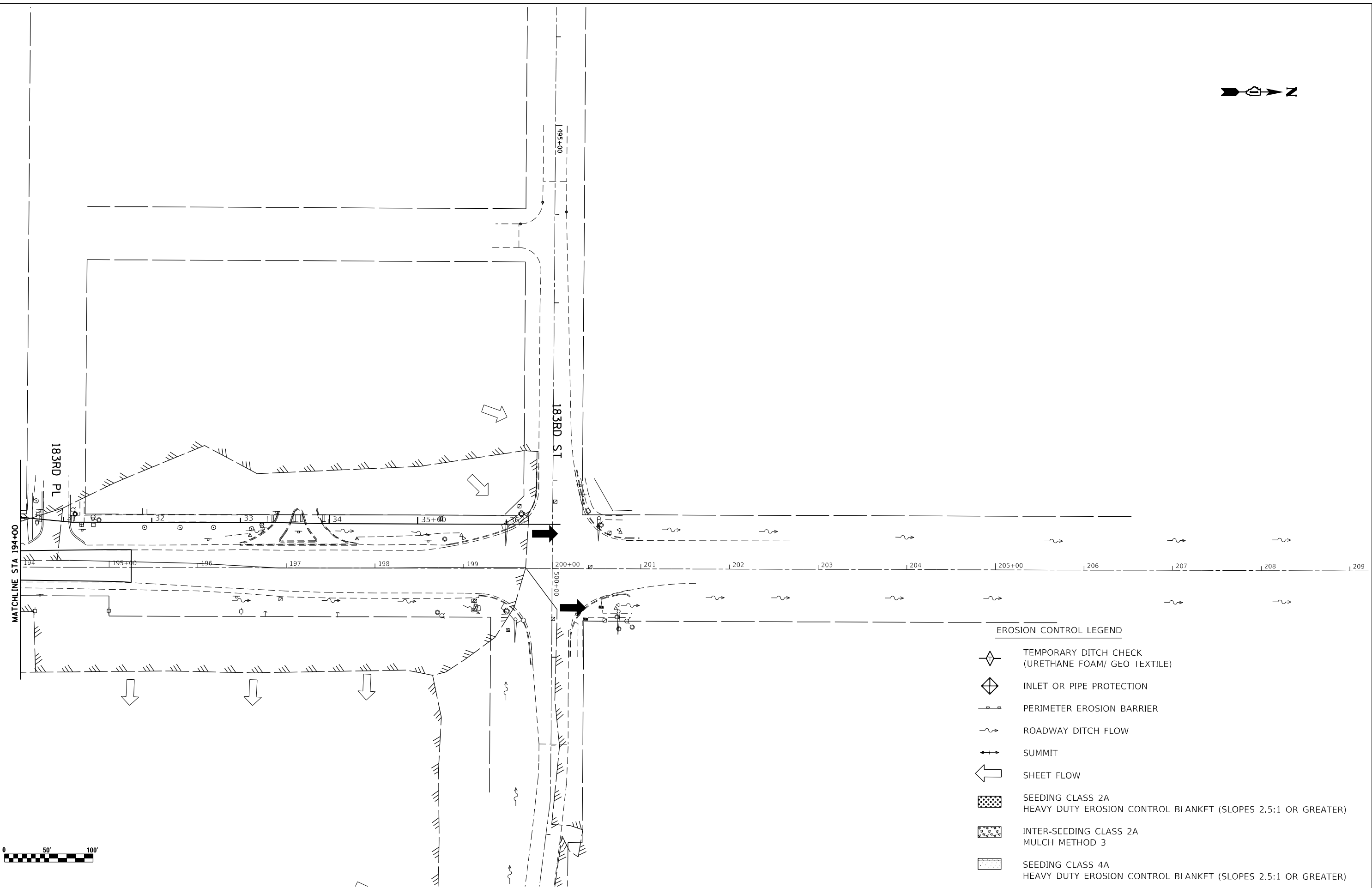

EROSION CONTROL PLAN
WOLF ROAD BRIDGE OVER I-80

F.A.P. RTE.	SECTION	COUNTY	TOTAL SHEETS	SHEET NO.
2688	2020-250-BY	WILL	133	28
CONTRACT NO. 62N20				
ILLINOIS FED. AID PROJECT				

SCALE: SHEET OF SHEETS STA. TO STA.



EROSION CONTROL LEGEND

-  TEMPORARY DITCH CHECK (URETHANE FOAM/ GEO TEXTILE)
-  INLET OR PIPE PROTECTION
-  PERIMETER EROSION BARRIER
-  ROADWAY DITCH FLOW
-  SUMMIT
-  SHEET FLOW
-  SEEDING CLASS 2A
HEAVY DUTY EROSION CONTROL BLANKET (SLOPES 2.5:1 OR GREATER)
-  INTER-SEEDING CLASS 2A
MULCH METHOD 3
-  SEEDING CLASS 4A
HEAVY DUTY EROSION CONTROL BLANKET (SLOPES 2.5:1 OR GREATER)

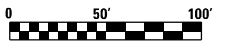

MODEL: Default
 FILE NAME: \\primera-pw-bca\p\proj\2020\20200425\00 - IDOT Phase II Wolf Road over I-80\Drawings\Contract_Drawing_Plot\CADD_Sheet\Roadway\0113233.dwg-crs03.dgn
 PROJECT: 2020\20200425\00 - IDOT Phase II Wolf Road over I-80\Drawings\Contract_Drawing_Plot\CADD_Sheet\Roadway\0113233.dwg-crs03.dgn
 USER: RM
 DATE: 2/2/2022



USER NAME = rmartin	DESIGNED - RM/RMV	REVISED -
DRAWN - RM/RMV	REVISIONS -	
PLOT SCALE = 100,0034' / in.	CHECKED - MPV	REVISED -
PLOT DATE = 2/2/2022	DATE - 07/07/2021	REVISED -

**STATE OF ILLINOIS
DEPARTMENT OF TRANSPORTATION**

**EROSION CONTROL PLAN
WOLF ROAD BRIDGE OVER I-80**

SCALE: SHEET OF SHEETS STA. TO STA.

F.A.P. RTE. 2688	SECTION 2020-250-BY	COUNTY WILL	TOTAL SHEETS 133	SHEET NO. 29
CONTRACT NO. 62N20				
ILLINOIS FED. AID PROJECT				

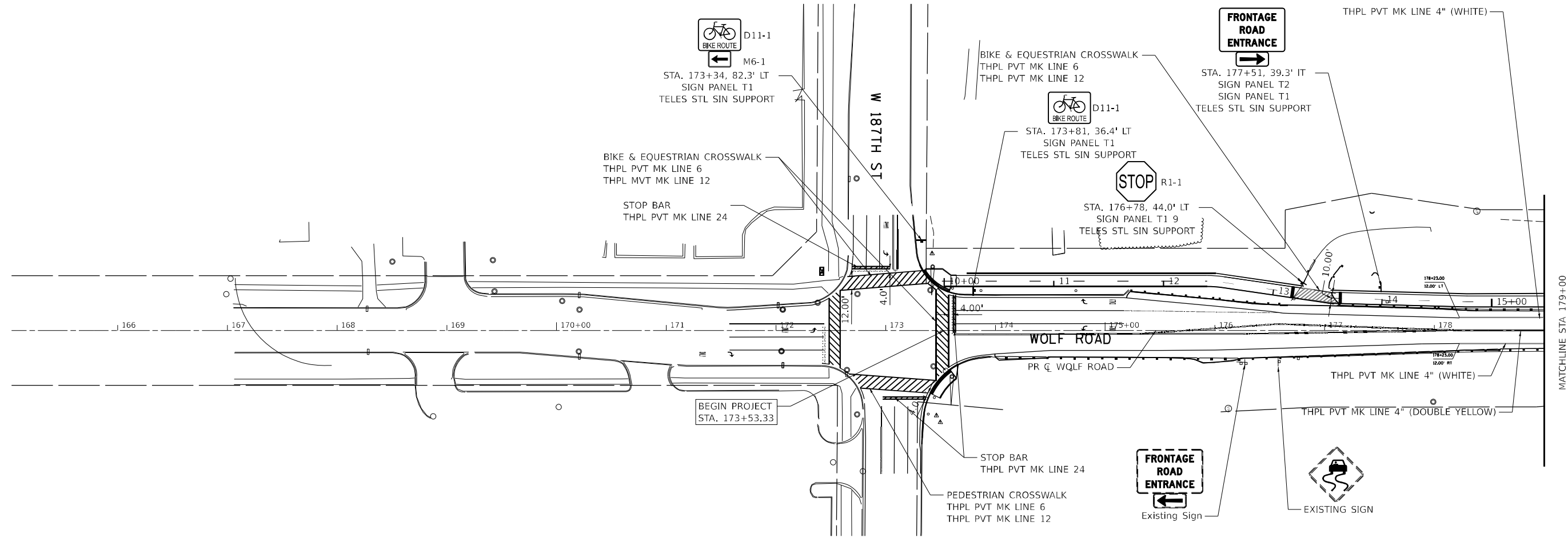

NOTE: CONTRACTOR SHALL NOT PLACE SIGNING OR ANY OTHER LATERAL OBSTRUCTIONS WITHIN 3' OF THE EDGE OF THE SHARED-USE PATH ON EITHER SIDE.

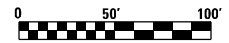

MODEL: Default
 FILE: \\nautilus.primera.com\primera-ops\01\Documents\01\Project\2020\20200425_00 - IDOT Phase II Veribus Design\20200425_01_WO 1-3 - Wolf Road over I-80\Drawings\Current Drawing Files\CADD_Sheets\Roadway\0112233-rlt-spmk-01.dwg
 461 N. JACKSON BLVD, SUITE 600, CHICAGO, IL 60611, P.312.460.4000 F.312.460.4015



USER NAME = rvandermus	DESIGNED - RM/RMV	REVISED -
DRAWN - RM/RMV	REVISED -	
PLOT SCALE = 100,0000' / in.	CHECKED - MPV	REVISED -
PLOT DATE = 3/16/2022	DATE - 07/07/2021	REVISED -

**STATE OF ILLINOIS
DEPARTMENT OF TRANSPORTATION**

PAVEMENT MARKING & SIGNING PLAN			
WOLF ROAD BRIDGE OVER I-80			
SCALE:	SHEET	OF SHEETS	STA. TO STA.

F.A.I. RTE.	SECTION	COUNTY	TOTAL SHEETS	SHEET NO.
I-80	2020-250-BY	WILL	133	30
ILLINOIS FED. AID PROJECT			CONTRACT NO. 62N20	

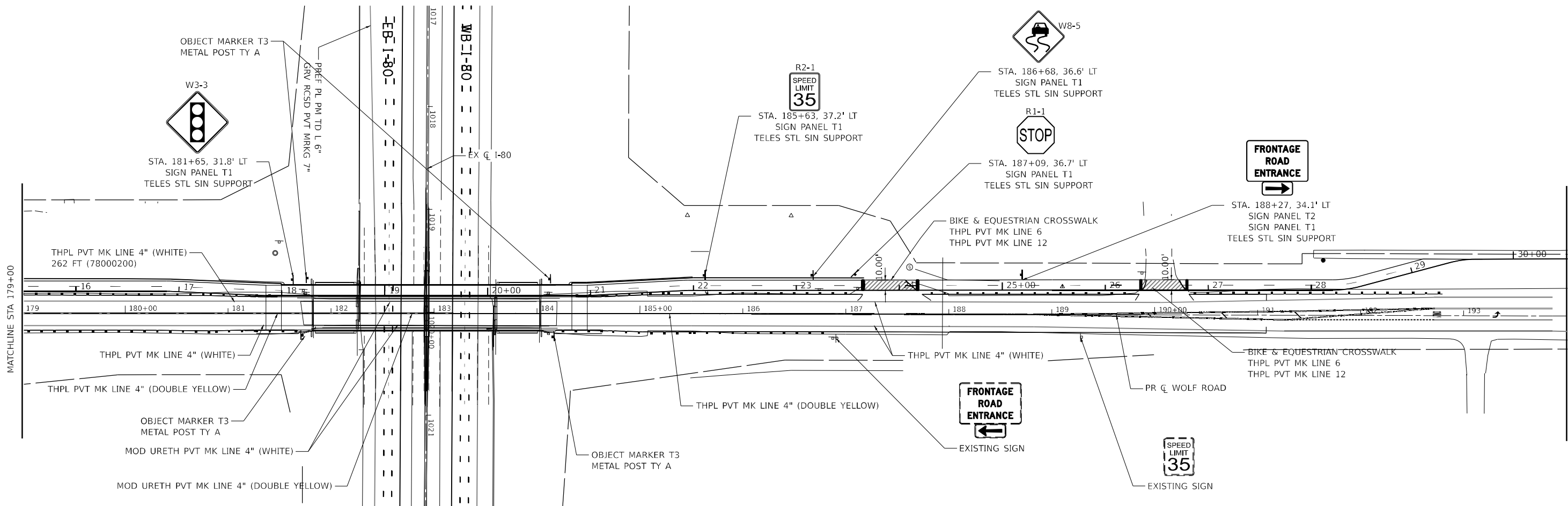

NOTE: CONTRACTOR SHALL NOT PLACE SIGNING OR ANY OTHER LATERAL OBSTRUCTIONS WITHIN 3' OF THE EDGE OF THE SHARED-USE PATH ON EITHER SIDE.



USER NAME = rvandermus	DESIGNED - RM/RMV	REVISED -
DRAWN - RM/RMV	REVISED -	
PLOT SCALE = 100,0000' / in.	CHECKED - MPV	REVISED -
PLOT DATE = 3/16/2022	DATE - 07/07/2021	REVISED -

**STATE OF ILLINOIS
DEPARTMENT OF TRANSPORTATION**

**PAVEMENT MARKING & SIGNING PLAN
WOLF ROAD BRIDGE OVER I-80**

SCALE: SHEET OF SHEETS STA. TO STA.

F.A.I. RTE.	SECTION	COUNTY	TOTAL SHEETS	SHEET NO.
I-80	2020-250-BY	WILL	133	31
CONTRACT NO. 62N20			ILLINOIS FED. AID PROJECT	

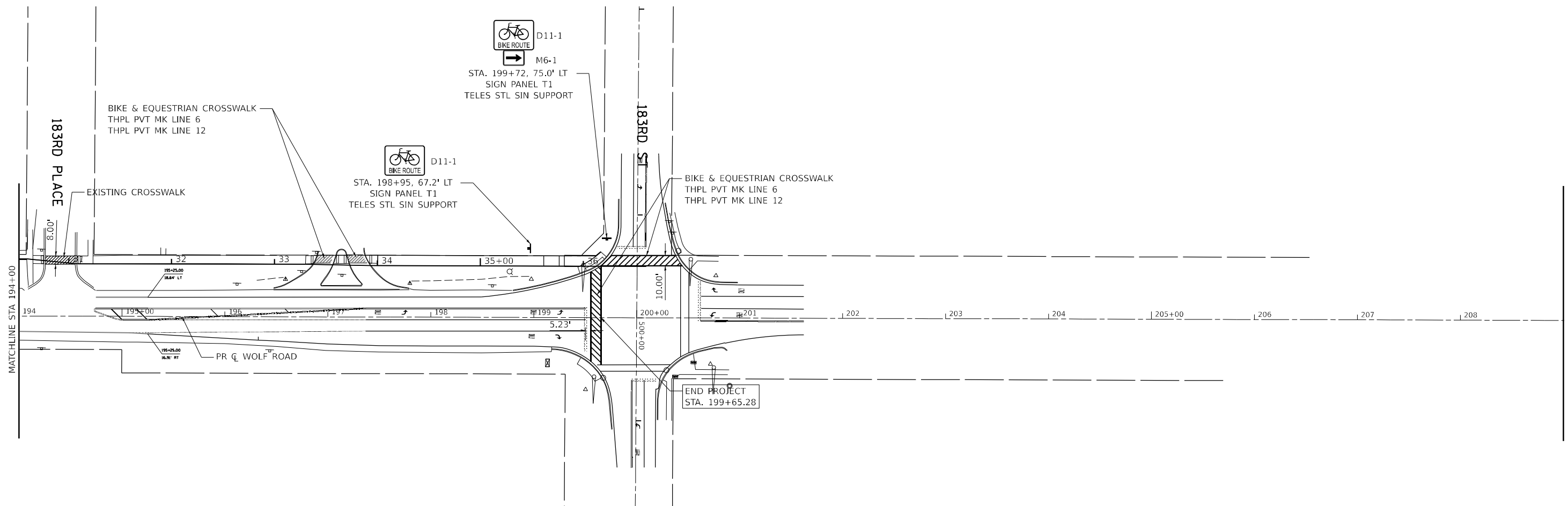

NOTE: CONTRACTOR SHALL NOT PLACE SIGNING OR ANY OTHER LATERAL OBSTRUCTIONS WITHIN 3' OF THE EDGE OF THE SHARED-USE PATH ON EITHER SIDE.

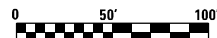

USER NAME = rvandermus	DESIGNED - RM/RMV	REVISED -
	DRAWN - RM/RMV	REVISED -
PLOT SCALE = 100,0000' / in.	CHECKED - MPV	REVISED -
PLOT DATE = 3/16/2022	DATE - 07/07/2021	REVISED -

**STATE OF ILLINOIS
DEPARTMENT OF TRANSPORTATION**

**PAVEMENT MARKING & SIGNING PLAN
WOLF ROAD BRIDGE OVER I-80**

SCALE: SHEET OF SHEETS STA. TO STA.

F.A.I. RTE.	SECTION	COUNTY	TOTAL SHEETS	SHEET NO.
I-80	2020-250-BY	WILL	133	32
ILLINOIS FED. AID PROJECT			CONTRACT NO. 62N20	

MODEL: Default
 FILE: \\nautilus.primera.com\primera\proj\62n20\2020\250-BY\DOT Phase II\Veribus Designer\20200425_01_WO 1-3 - Wolf Road over I-80\Drawings\Current Drawings\CADD_Sheets\Radius\0112233-rlt-spm-03.dwg
 PROJECT: 2020-250-BY
 DATE: 3/16/2022

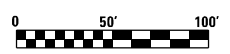
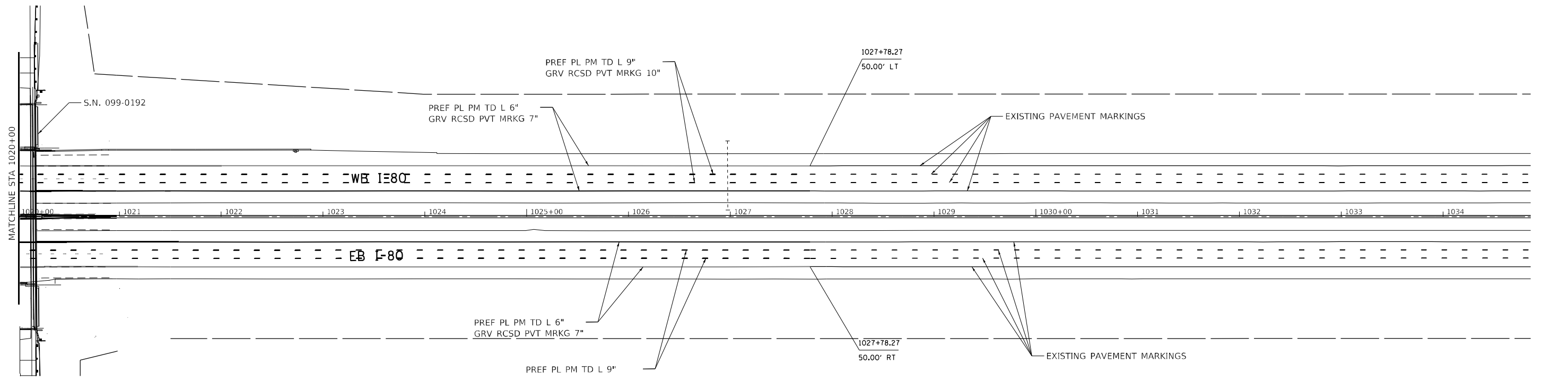
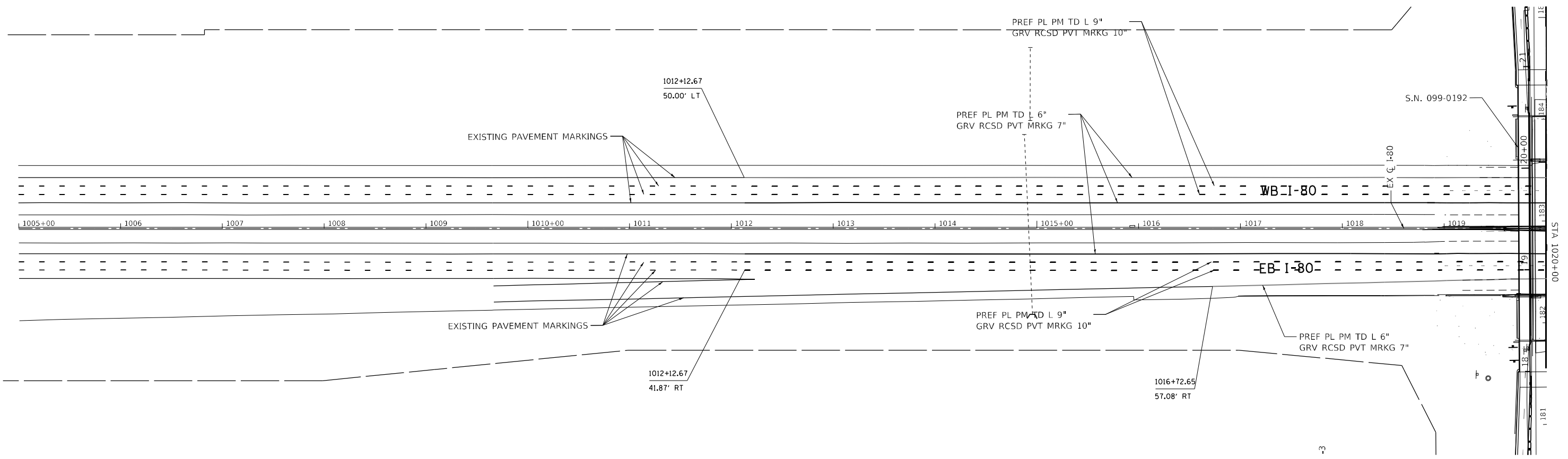

MODEL: Default
 FILE: \\MAILS\pub\primera\pk\ben\lfr\com\primera\proj\01\Documents\01 - Projects\2020\20200425.00 - IDOT Phase II Vertical Design\Drawings\Current Drawing Files\CADD_Sheets\Bosley\0113232-sub-prim-04.dwg
 401 N. JACKSON BLVD, SUITE 400, CHICAGO, IL 60611, P.312-467-0910 F.312-467-0915



USER NAME = rmartin
 PLOT SCALE = 100,0000' / in.
 PLOT DATE = 2/2/2022

DESIGNED - RM/RMV
 DRAWN - RM/RMV
 CHECKED - MPV
 DATE - 07/07/2021

REVISED -
 REVISED -
 REVISED -
 REVISED -

**STATE OF ILLINOIS
 DEPARTMENT OF TRANSPORTATION**

**PAVEMENT MARKING & SIGNING PLAN
 WOLF ROAD BRIDGE OVER I-80**

SCALE: SHEET OF SHEETS STA. TO STA.

F.A.P. RTE.	SECTION	COUNTY	TOTAL SHEETS	SHEET NO.
2688	2020-250-BY	WILL	133	33
CONTRACT NO. 62N20				
ILLINOIS FED. AID PROJECT				

MODEL: D:\default...
 FILE: I:\M&E...
 501 N. JACKSON BLVD, SUITE 600, CHICAGO, IL 60611, P.312-465-4913 F.312-465-4915

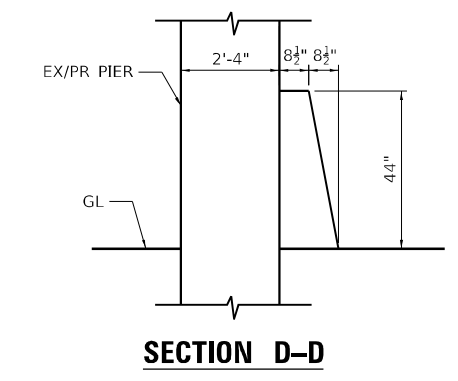
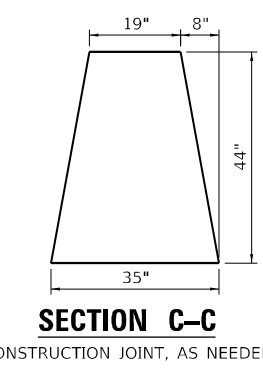
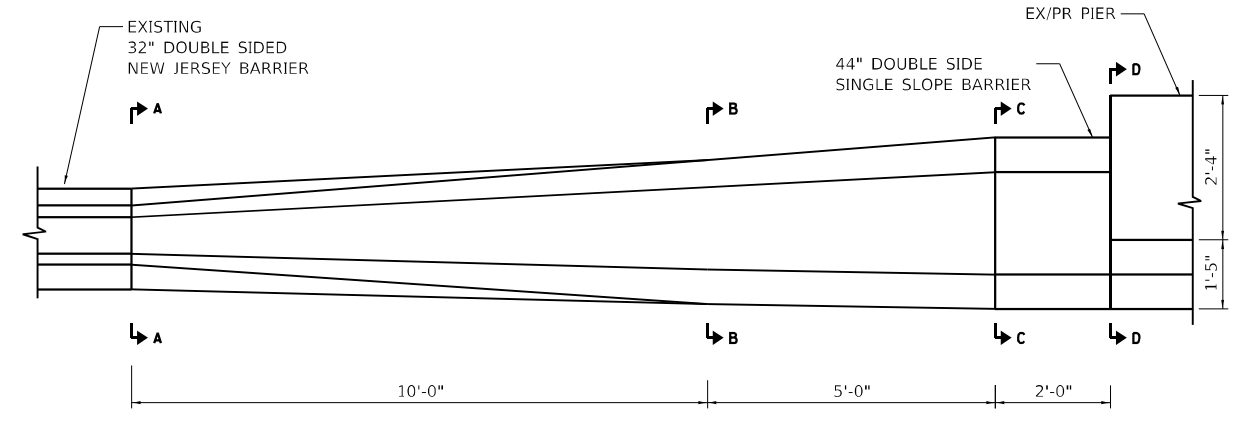
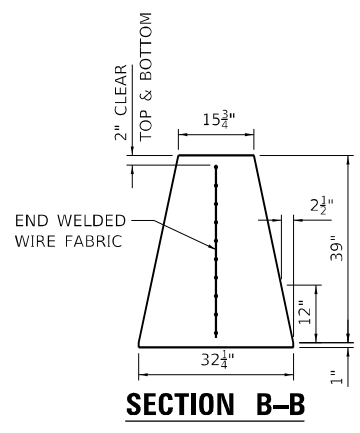
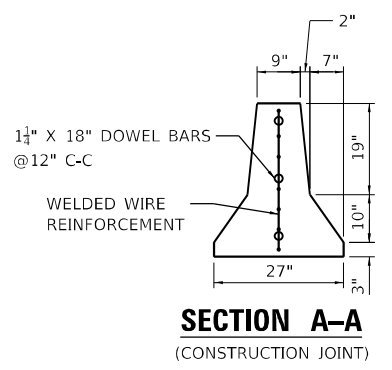
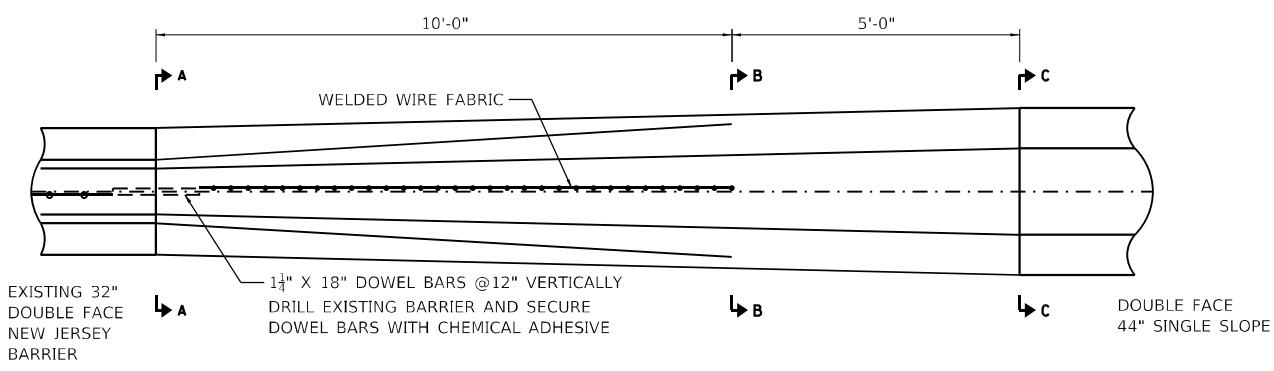

TRANSITION FROM 32" DOUBLE SIDE NEW JERSEY BARRIER TO 44" DOUBLE SIDE SINGLE SLOPE BARRIER

BARRIER TRANSITION AT PIER 1 & 3

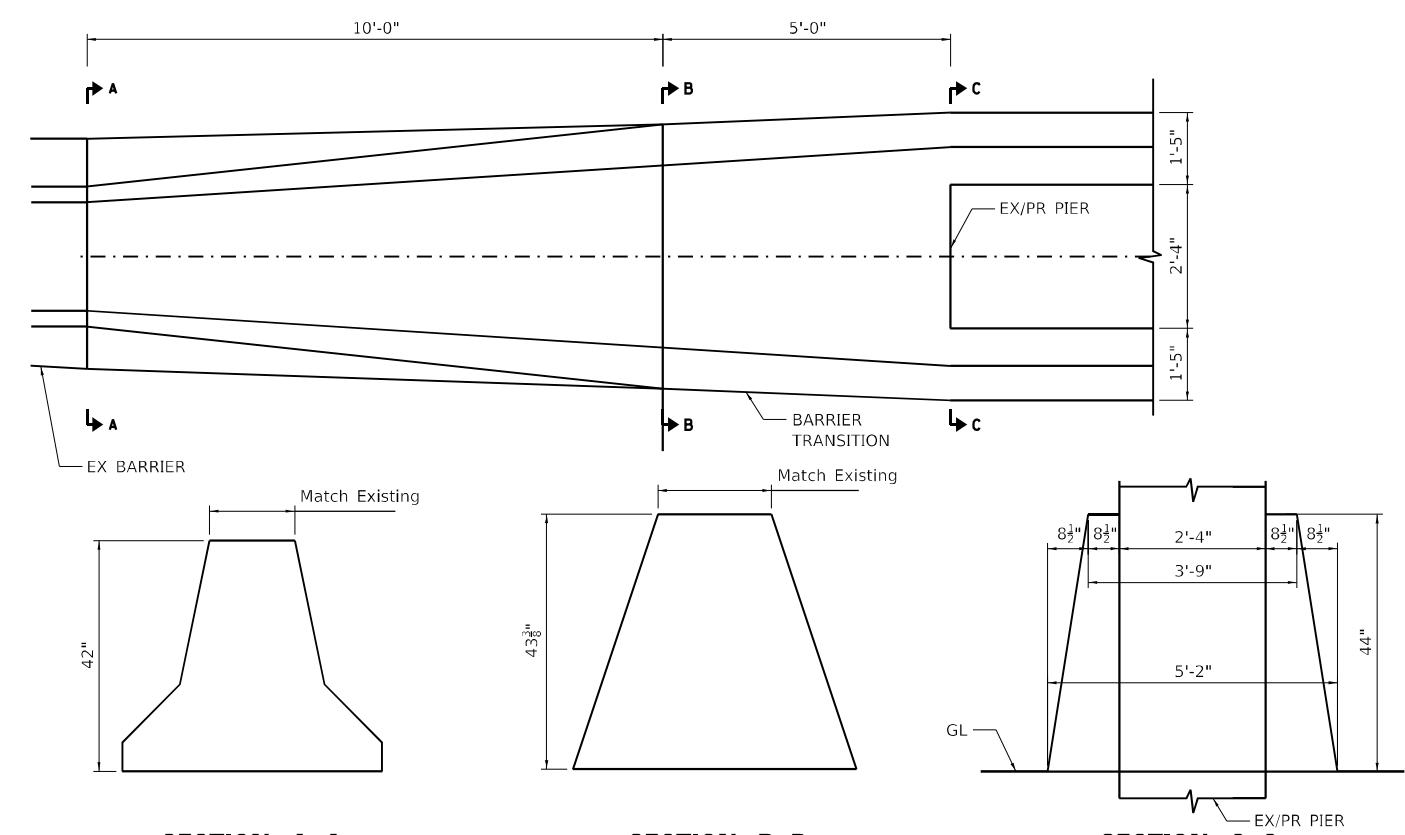

BARRIER TRANSITION AT CENTER PIER

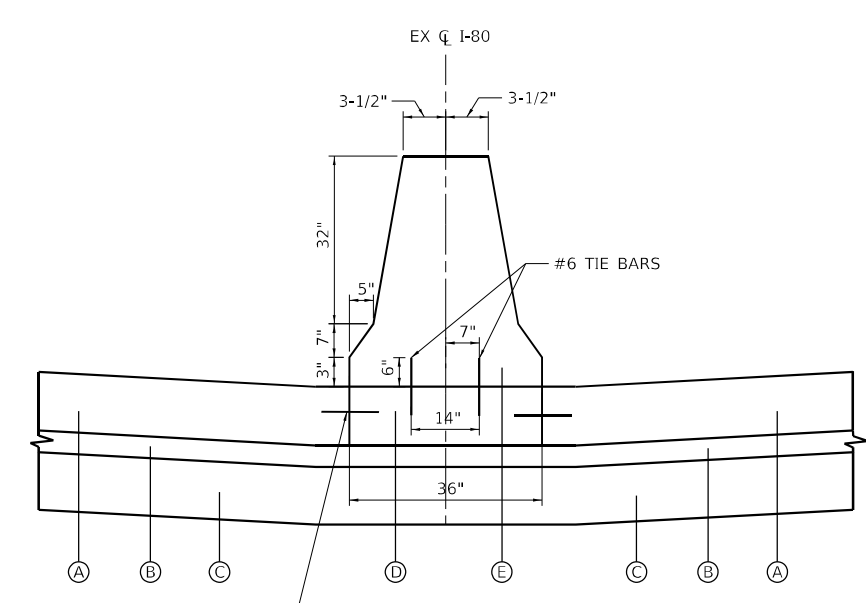

EXISTING CONCRETE BARRIER, DOUBLE FACE, 42" HEIGHT (FOR INFORMATION ONLY)

LEGEND

- (A) PORTLAND CEMENT CONCRETE SHOULDER
- (B) STABILIZED SUBBASE
- (C) AGGREGATE SUBGRADE
- (D) CONCRETE BARRIER BASE
- (E) CONCRETE BARRIER, DOUBLE FACE, 42" HEIGHT

PIER 1 & PIER 3 STATIONS

SECTION	PIER 1 STATION	PIER 3 STATION
A-A	1020+25.49	1019+57.35
B-B	1020+15.49	1019+67.35
C-C	1020+10.49	1019+72.35
D-D	1020+08.49	1019+74.35

PIER 2 STATIONS

SECTION	PIER 2 WEST STATION	PIER 2 EAST STATION
A-A	1019+59.35	1020+23.62
B-B	1019+69.35	1020+13.62
C-C	1019+74.35	1020+08.62



USER NAME = rmartin	DESIGNED - RM/RMV	REVISED -
PLOT SCALE = 10,0009' / in.	DRAWN - RM/RMV	REVISED -
PLOT DATE = 2/2/2022	CHECKED - MPV	REVISED -
	DATE - 07/07/2021	REVISED -

**STATE OF ILLINOIS
DEPARTMENT OF TRANSPORTATION**

**CONCRETE MEDIAN BARRIER TRANSITION DETAIL
WOLF ROAD BRIDGE OVER I-80**

SCALE: SHEET OF SHEETS STA. TO STA.

F.A.P. RTE. 2688	SECTION 2020-250-BY	COUNTY WILL	TOTAL SHEETS 133	SHEET NO. 34
ILLINOIS FED. AID PROJECT			CONTRACT NO. 62N20	

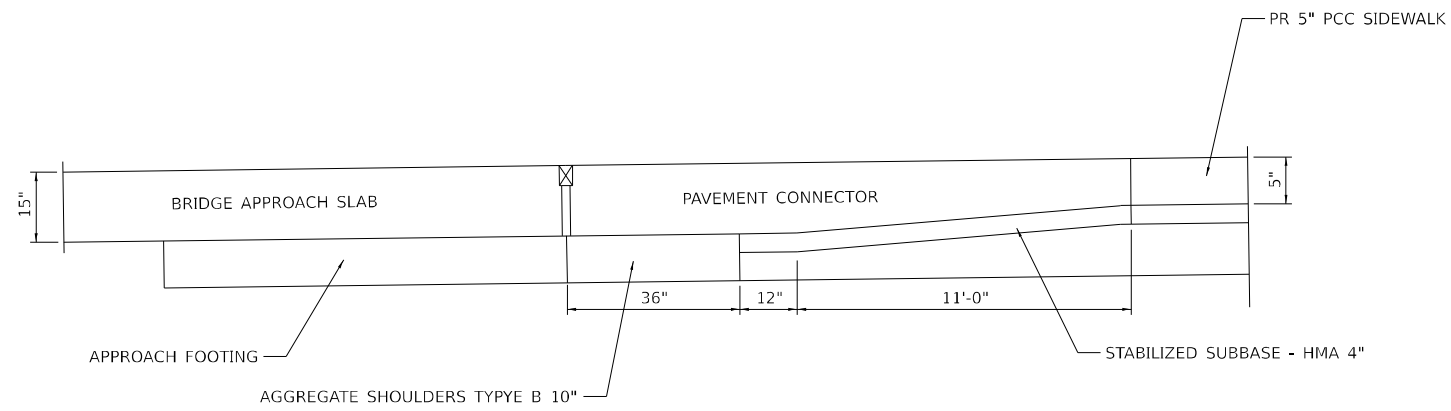

PCC CONNECTOR DETAIL FOR SHARED USE PATH

MODEL: Default
 FILE: \\MAILS01\primera\pwworkspace\benlley.com\primera\pwworkspace\Documents\01_P\Project\2020\20200425_00 - IDOT Phase II Verbus Designer\20200425_01_WO 1-3 - Wolf Road over I-80 Drawings\Current Drawing Files\CADD_Sheets\Radius\0112233-dt-detail-PCCConnector.dgn
 461 N. JACKSON BLVD, SUITE 600, CHICAGO, IL 60611, P.312-467-4910 F.312-467-4915



USER NAME = rvandermus	DESIGNED - RM/RMV	REVISED -
	DRAWN - RM/RMV	REVISED -
PLOT SCALE = 10,0000 * / in.	CHECKED - MPV	REVISED -
PLOT DATE = 3/10/2022	DATE - 07/07/2021	REVISED -

**STATE OF ILLINOIS
DEPARTMENT OF TRANSPORTATION**

PCC CONNECTOR DETAIL WOLF ROAD BRIDGE OVER I-80			
SCALE:	SHEET	OF	SHEETS
	STA.	TO	STA.

F.A.I. RTE.	SECTION	COUNTY	TOTAL SHEETS	SHEET NO.
I-80	2020-250-BY	WILL	133	35
			CONTRACT NO. 62N20	
		ILLINOIS FED. AID PROJECT		

MODEL: Default
 FILE: \\nautilus.primera.com\primera\proj\01\Documents\01\Project\2020\04\25\200 - IDOT Phase II Verbus Design\20200425.01_WO 1-3 - Wolf Road over I-80\Drawings\Current\Drawings\Files\CADD_Sheets\Radius\01123233-rt-a-ds-01.dwg
 401 N. JACKSON BLVD, SUITE 600, CHICAGO, IL 60611, P.312-465-4000 F.312-465-4005

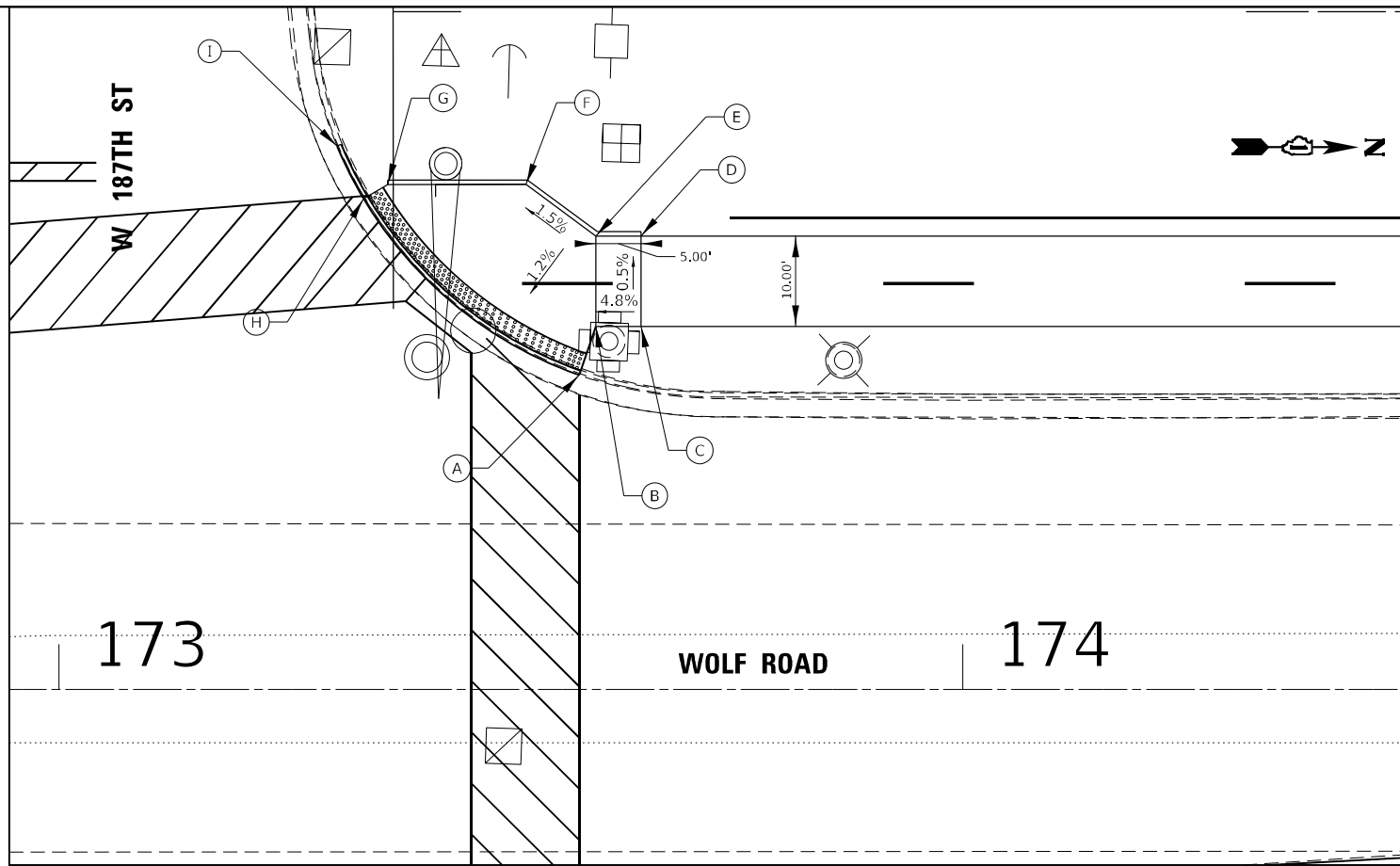

POINT	STATION	OFFSET	ELEVATION
A	173+57.57	34.79 LT	(716.47) MATCH EX.
B	173+59.40	40.18 LT	716.55
C	173+64.40	40.18 LT	716.79
D	173+64.40	50.18 LT	716.89
E	173+59.40	50.18 LT	716.65
F	173+51.68	55.90 LT	716.50
G	173+36.36	55.89 LT	716.32
H	173+33.71	54.29 LT	716.28
I	173+30.77	60.15 LT	(714.16) MATCH EX.

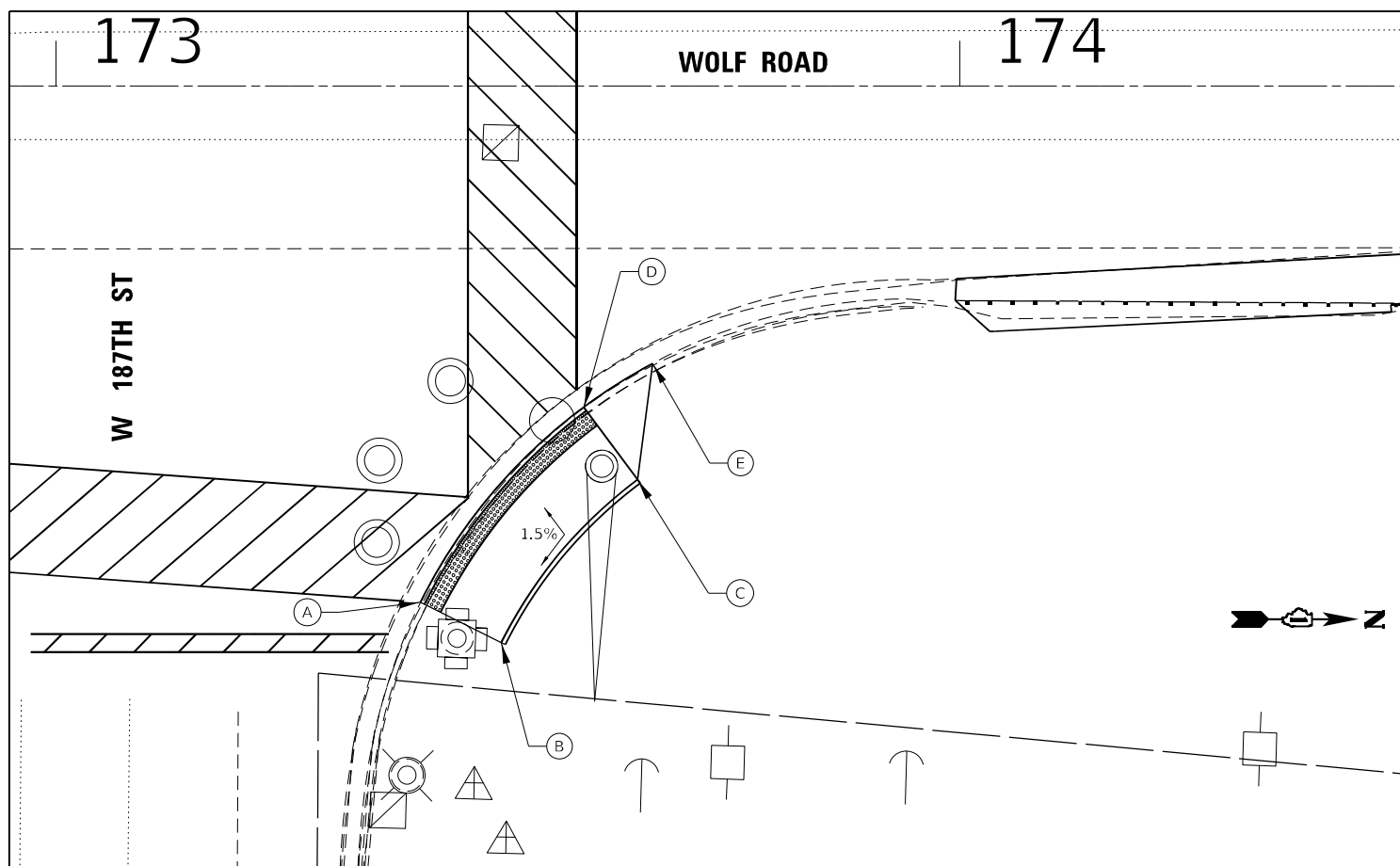

POINT	STATION	OFFSET	ELEVATION
A	173+40.30	57.17 RT	(714.89) MATCH EX.
B	173+49.26	61.62 RT	715.05
C	173+70.51	39.52 RT	715.42
D	173+66.00	60.70 RT	715.26
E	173+71.03	28.31 RT	(716.21) MATCH EX.



USER NAME = rvandermus	DESIGNED - RM/RMV	REVISED -
DRAWN - RM/RMV	REVISIONS	
PLOT SCALE = 20,0000 * / in.	CHECKED - MPV	REVISED -
PLOT DATE = 3/16/2022	DATE - 07/07/2021	REVISED -

STATE OF ILLINOIS
DEPARTMENT OF TRANSPORTATION

ADA DETAILS
WOLF ROAD BRIDGE OVER I-80

SCALE: SHEET OF SHEETS STA. TO STA.

F.A.I. RTE.	SECTION	COUNTY	TOTAL SHEETS	SHEET NO.
I-80	2020-250-BY	WILL	133	36
CONTRACT NO. 62N20			ILLINOIS FED. AID PROJECT	

MODEL: Default
 FILE: \\nautilus.primera.com\primera-ops\01\Documents\01\Project\2020\04\25\200 - IDOT Phase II Verbus Design\2020\04\25\01_WO 1-3 - Wolf Road over I-80\Drawings\Current Drawing Files\CADD_Sheets\Radius\0112233-rt-ada-03.dwg
 461 N. JACKSON BLVD, SUITE 600, CHICAGO, IL 60611, P.312-462-4000 F.312-462-4005

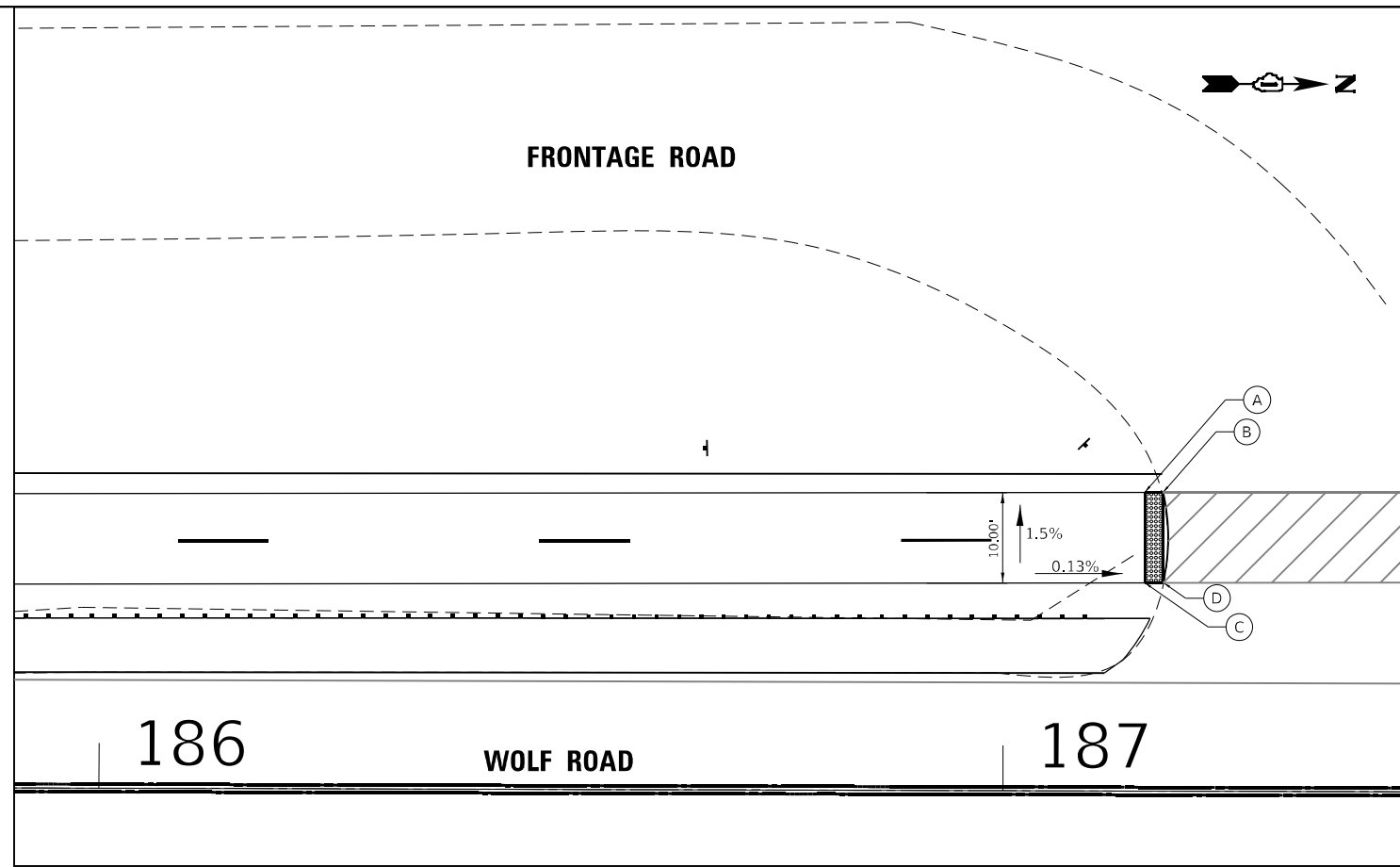

POINT	STATION	OFFSET	ELEVATION
A	187+15.69	33.03 LT	737.51
B	187+17.63	33.04 LT	737.50
C	187+15.69	23.03 LT	737.36
D	187+17.63	23.04 LT	737.35

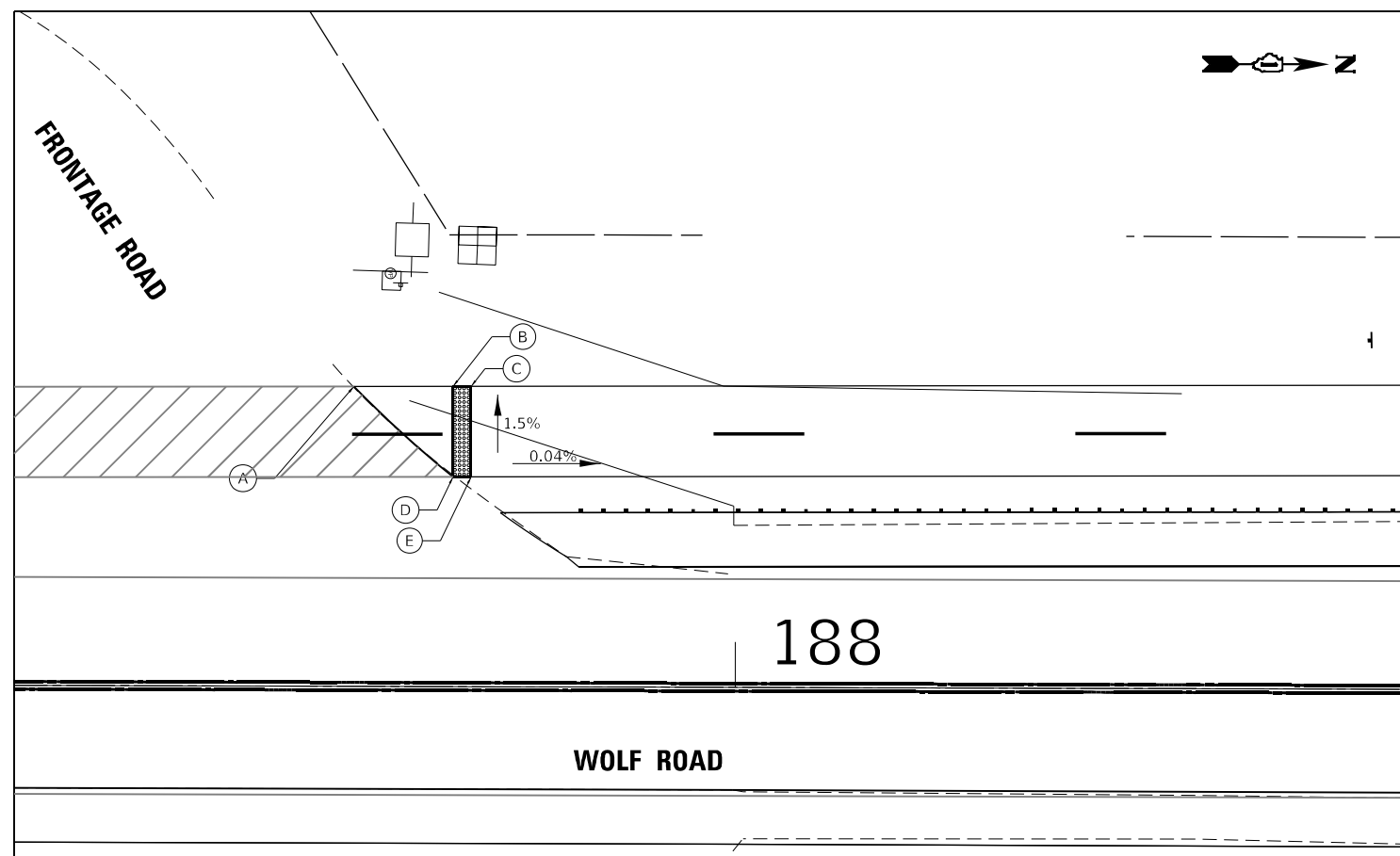

POINT	STATION	OFFSET	ELEVATION
A	187+57.65	33.13 LT	737.15
B	187+68.72	33.13 LT	737.16
C	187+70.08	33.13 LT	737.17
D	187+68.72	23.17 LT	736.96
E	187+70.08	23.17 LT	736.97



USER NAME = rvandermus	DESIGNED - RM/RMV	REVISED -
PLOT SCALE = 20,0000 * / in.	DRAWN - RM/RMV	REVISED -
PLOT DATE = 3/16/2022	CHECKED - MPV	REVISED -
	DATE - 07/07/2021	REVISED -

STATE OF ILLINOIS
DEPARTMENT OF TRANSPORTATION

ADA DETAILS			
WOLF ROAD BRIDGE OVER I-80			
SCALE:	SHEET	OF SHEETS	STA. TO STA.

F.A.I. RTE.	SECTION	COUNTY	TOTAL SHEETS	SHEET NO.
I-80	2020-250-BY	WILL	133	38
				CONTRACT NO. 62N20
ILLINOIS FED. AID PROJECT				

MODEL: D:\default...
 FILE: I:\MULES...
 461 N. JACKSON BLDG, SUITE 600, CHICAGO, IL 60611, P.312-467-4000 F.312-467-4015

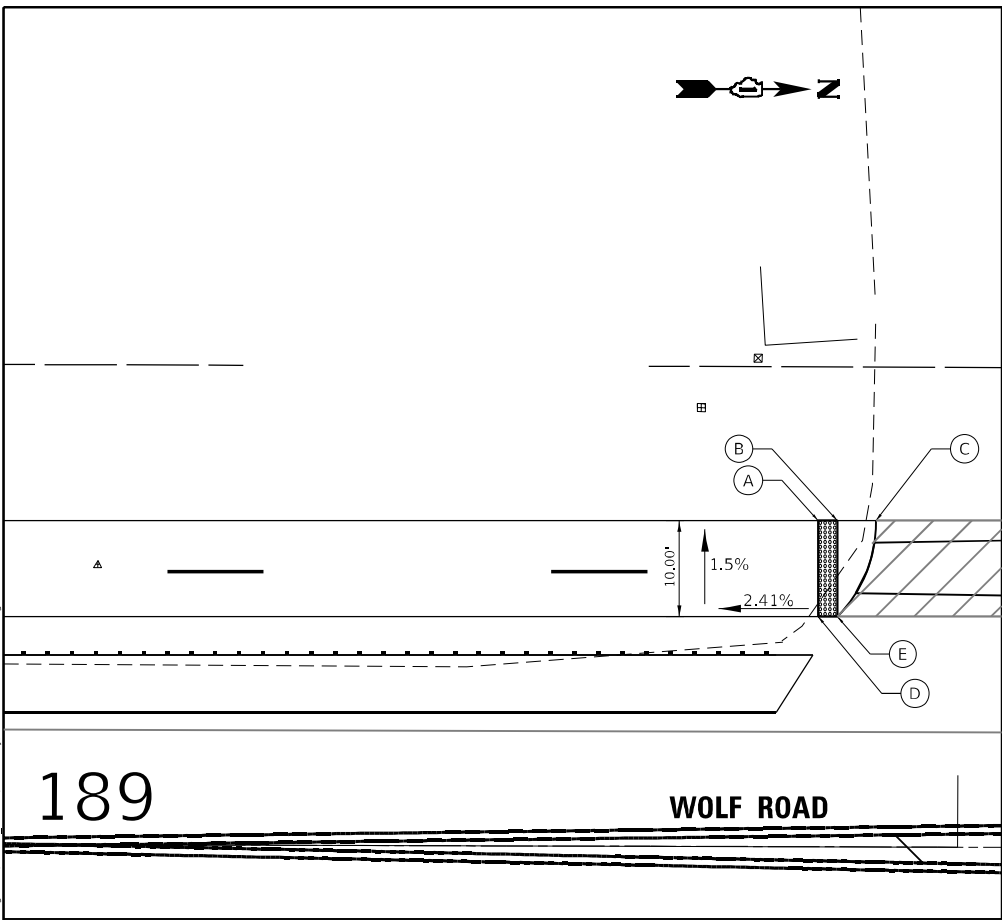

POINT	STATION	OFFSET	ELEVATION
A	189+85.47	33.98 LT	735.66
B	189+87.38	33.98 LT	735.66
C	189+91.40	33.98 LT	735.65
D	189+85.47	23.98 LT	735.52
E	189+87.38	23.96 LT	735.51

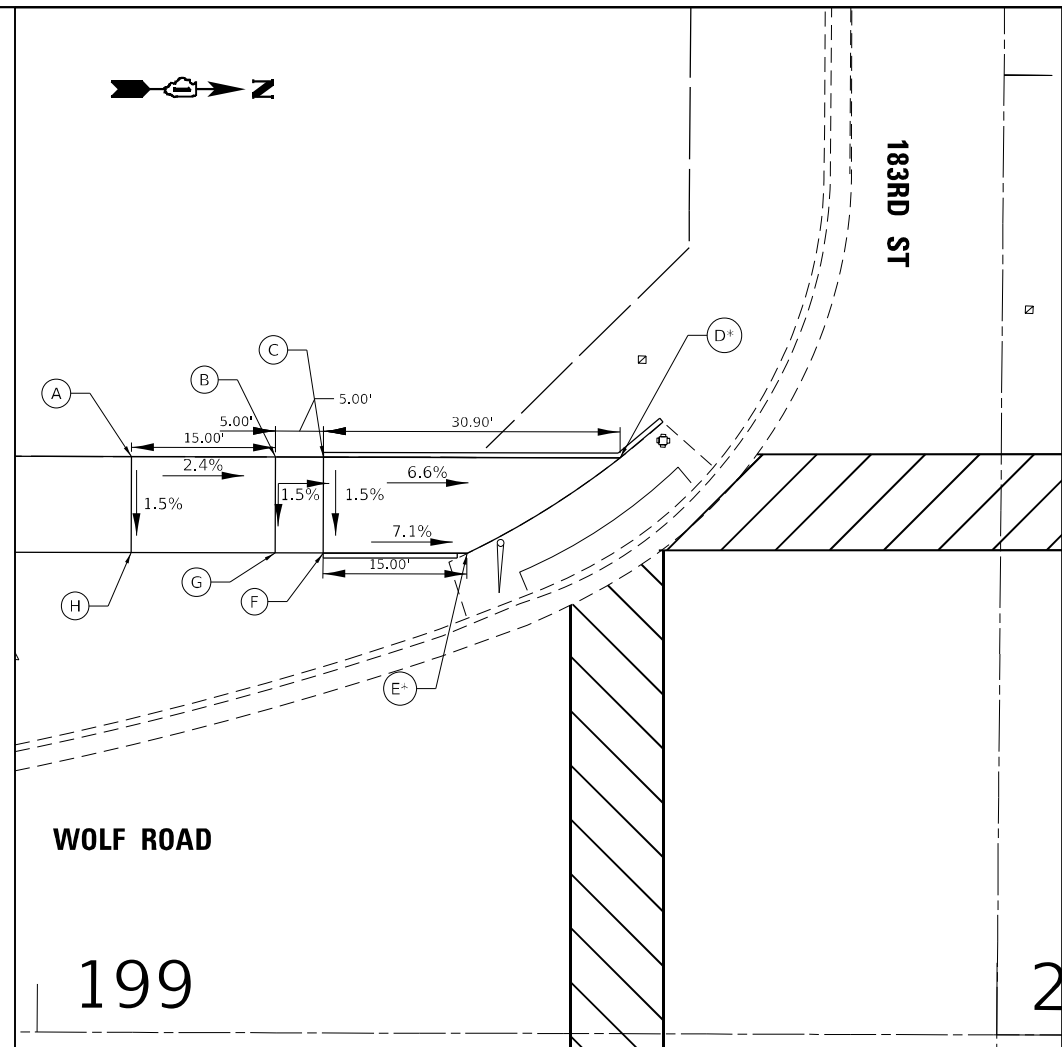

POINT	STATION	OFFSET	ELEVATION
A	199+09.79	60.00 LT	727.84
B	199+24.80	60.00 LT	727.48
C	199+29.80	60.00 LT	727.41
D*	199+60.70	60.00 LT	MATCH EXISTING
E*	199+44.80	50.00 LT	MATCH EXISTING
F	199+29.80	50.00 LT	727.26
G	199+24.80	50.00 LT	727.33
H	199+09.79	50.00 LT	727.69

* CONTRACTOR SHALL ENSURE THAT RUNNING AND CROSS SLOPE OF THE EXISTING SOUTHWEST ADA RAMP ON 183RD ST/WOLF RD ARE COMPLIANT PER ADA STANDARDS.

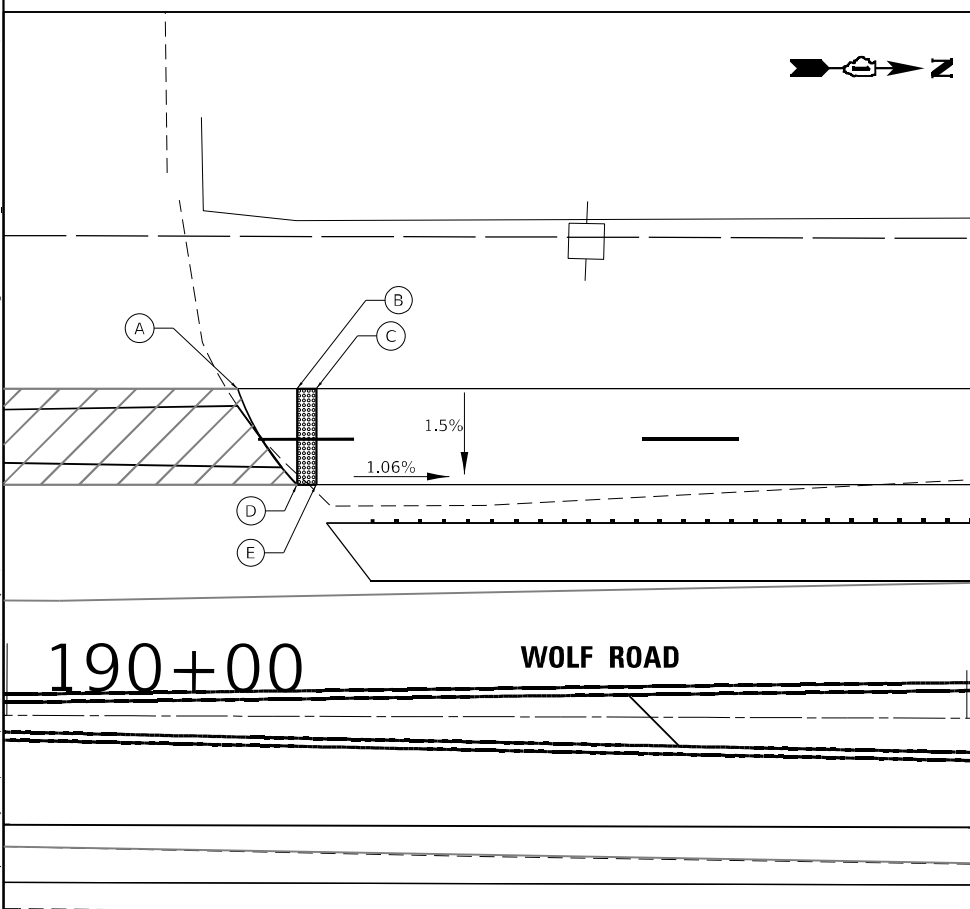

POINT	STATION	OFFSET	ELEVATION
A	190+23.92	34.12 LT	735.57
B	190+30.12	34.13 LT	735.51
C	190+32.22	34.14 LT	735.50
D	190+30.12	24.13 LT	735.36
E	190+32.23	24.14 LT	735.35



USER NAME = rvandermus	DESIGNED - RM/RMV	REVISED -
PLOT SCALE = 20,0000 * / in.	DRAWN - RM/RMV	REVISED -
PLOT DATE = 3/17/2022	CHECKED - MPV	REVISED -
	DATE - 07/07/2021	REVISED -

STATE OF ILLINOIS
DEPARTMENT OF TRANSPORTATION

ADA DETAILS
WOLF ROAD BRIDGE OVER I-80

SCALE: SHEET OF SHEETS STA. TO STA.

F.A.I. RTE. I-80	SECTION 2020-250-BY	COUNTY WILL	TOTAL SHEETS 133	SHEET NO. 39
			CONTRACT NO. 62N20	
ILLINOIS FED. AID PROJECT				

MODEL: Default
 FILE NAME: g:\supp\mcs-pw-beat\fy.comput\mcs-pw-01\Documents\01 - Projects\2020\2020\25.00 - DDOT Phase II Vertical Design\Drawings\2020\25.01 - WO 1-3 - Wolf Road over I-80\Drawings\Current Drawing Files\CADD_Sheets\Drawings\0123233-ent-Drenovs-01.dgn

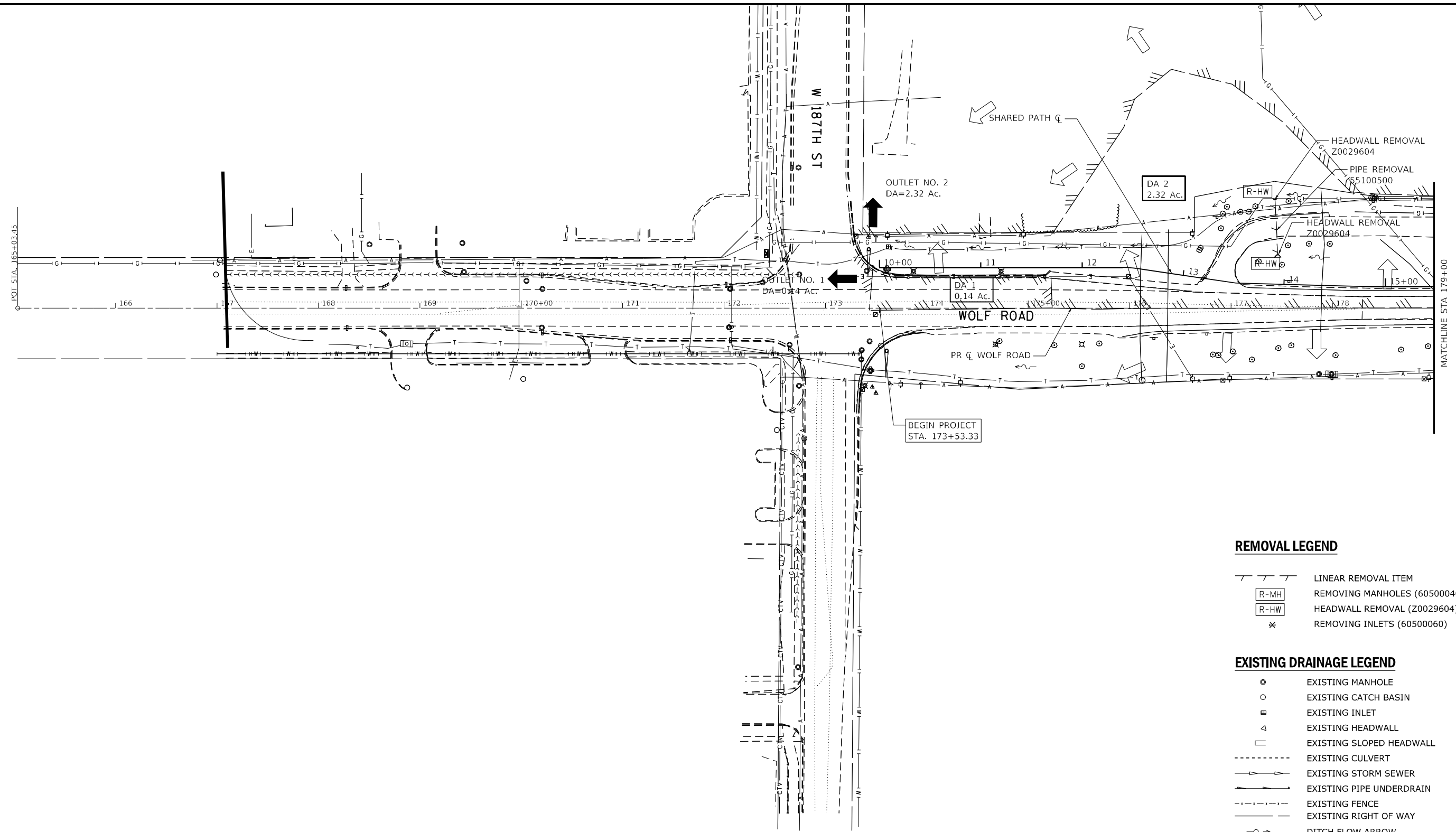

- REMOVAL LEGEND**
- LINEAR REMOVAL ITEM
 - R-MH REMOVING MANHOLES (60500040)
 - R-HW HEADWALL REMOVAL (Z0029604)
 - R-IN REMOVING INLETS (60500060)
- EXISTING DRAINAGE LEGEND**
- EXISTING MANHOLE
 - EXISTING CATCH BASIN
 - EXISTING INLET
 - EXISTING HEADWALL
 - EXISTING SLOPED HEADWALL
 - EXISTING CULVERT
 - EXISTING STORM SEWER
 - EXISTING PIPE UNDERDRAIN
 - EXISTING FENCE
 - EXISTING RIGHT OF WAY
 - DITCH FLOW ARROW
 - EXISTING WOUS / WETLAND (SITE XX)



USER NAME = rmartin	DESIGNED - AA	REVISED -
PLOT SCALE = 100,0000' / in.	DRAWN - AA	REVISED -
PLOT DATE = 2/2/2022	CHECKED - RSL	REVISED -
	DATE - 07/07/2021	REVISED -

**STATE OF ILLINOIS
 DEPARTMENT OF TRANSPORTATION**

**DRAINAGE EXISTING AND REMOVAL PLAN
 WOLF ROAD BRIDGE OVER I-80**

SCALE: SHEET OF SHEETS STA. TO STA.

F.A.P. RTE. 2688	SECTION 2020-250-BY	COUNTY WILL	TOTAL SHEETS 133	SHEET NO. 40
CONTRACT NO. 62N20				
ILLINOIS FED. AID PROJECT				

MODEL: Default
 FILE: \\MAILSrv\pub\pwworkspace\pkaw_bentley.com\pwworkspace\01\Documents\01 - Projects\2020\20200425.00 - IDOT Phase II Wolf Road over I-80\Drawings\Current Drawing Files\CADD_Sheet\Drawings\02.dwg
 PROJECT: 2020\20200425.00 - IDOT Phase II Wolf Road over I-80\Drawings\Current Drawing Files\CADD_Sheet\Drawings\02.dwg

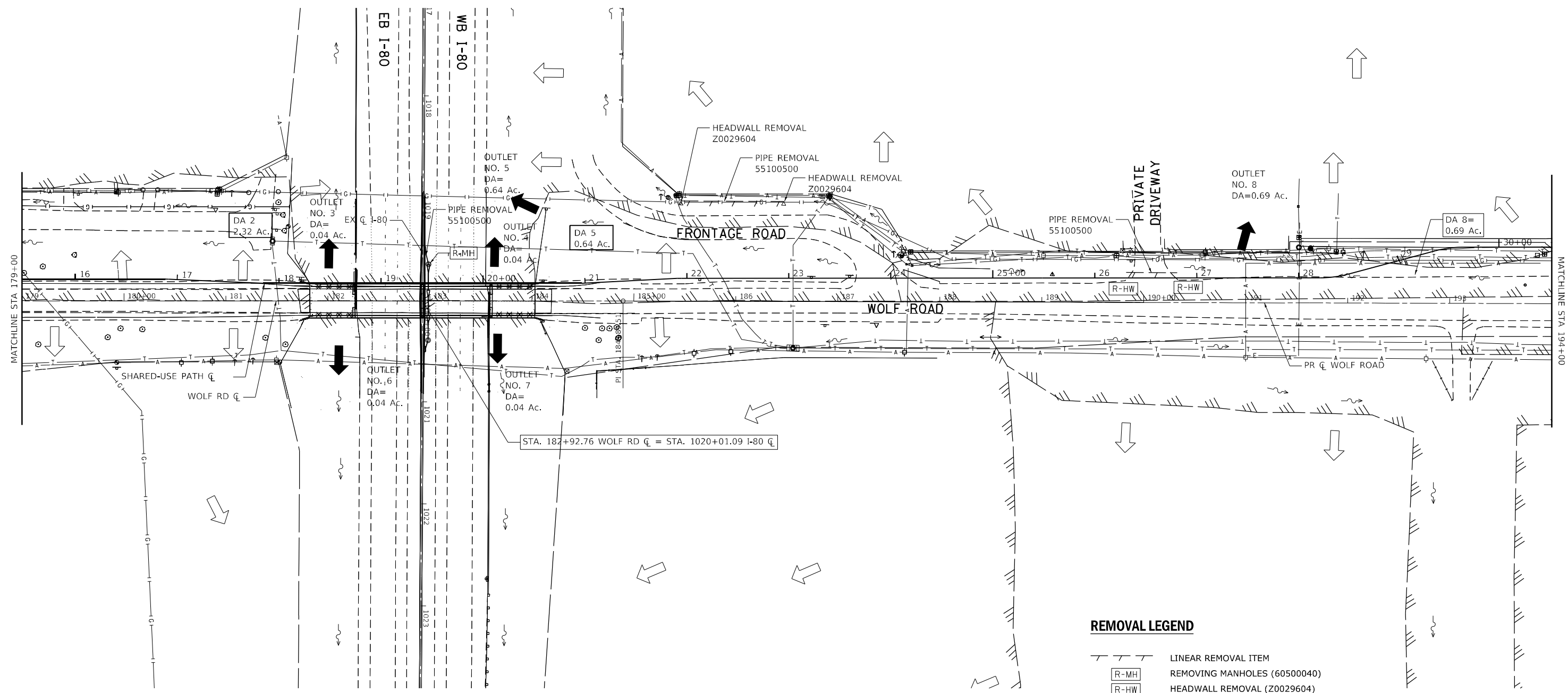

REMOVAL LEGEND

- LINEAR REMOVAL ITEM
- REMOVING MANHOLES (60500040)
- HEADWALL REMOVAL (Z0029604)
- REMOVING INLETS (60500060)

EXISTING DRAINAGE LEGEND

- EXISTING MANHOLE
- EXISTING CATCH BASIN
- EXISTING INLET
- EXISTING HEADWALL
- EXISTING SLOPED HEADWALL
- EXISTING CULVERT
- EXISTING STORM SEWER
- EXISTING PIPE UNDERDRAIN
- EXISTING FENCE
- EXISTING RIGHT OF WAY
- DITCH FLOW ARROW
- EXISTING WOUS / WETLAND (SITE XX)

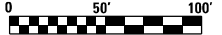
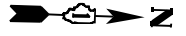

USER NAME = rmartin	DESIGNED - AA	REVISED -
DRAWN - AA	REVISED -	
PLOT SCALE = 100,0000' / in.	CHECKED - RSL	REVISED -
PLOT DATE = 2/2/2022	DATE - 07/07/2021	REVISED -

**STATE OF ILLINOIS
DEPARTMENT OF TRANSPORTATION**

**DRAINAGE EXISTING AND REMOVAL PLAN
WOLF ROAD BRIDGE OVER I-80**

SCALE: SHEET OF SHEETS STA. TO STA.

F.A.P. RTE. 2688	SECTION 2020-250-BY	COUNTY WILL	TOTAL SHEETS 133	SHEET NO. 41
CONTRACT NO. 62N20				
ILLINOIS FED. AID PROJECT				

MODEL: Default
 FILE: \\MAILSrv\pub\supp\mcrs-pw\benjefay.com\p1mcrs-pw\011\Documents\01 - Projects\2020\20200425.00 - IDOT Phase II Vertical Design\Drawings\20200425.01 - WO 1-3 - Wolf Road over I-80\Drawings\Current Drawing Files\CADD_Sheet\Drawings\03.dwg
 PROJECT: 2020\20200425.00 - IDOT Phase II Vertical Design\Drawings\20200425.01 - WO 1-3 - Wolf Road over I-80\Drawings\Current Drawing Files\CADD_Sheet\Drawings\03.dwg

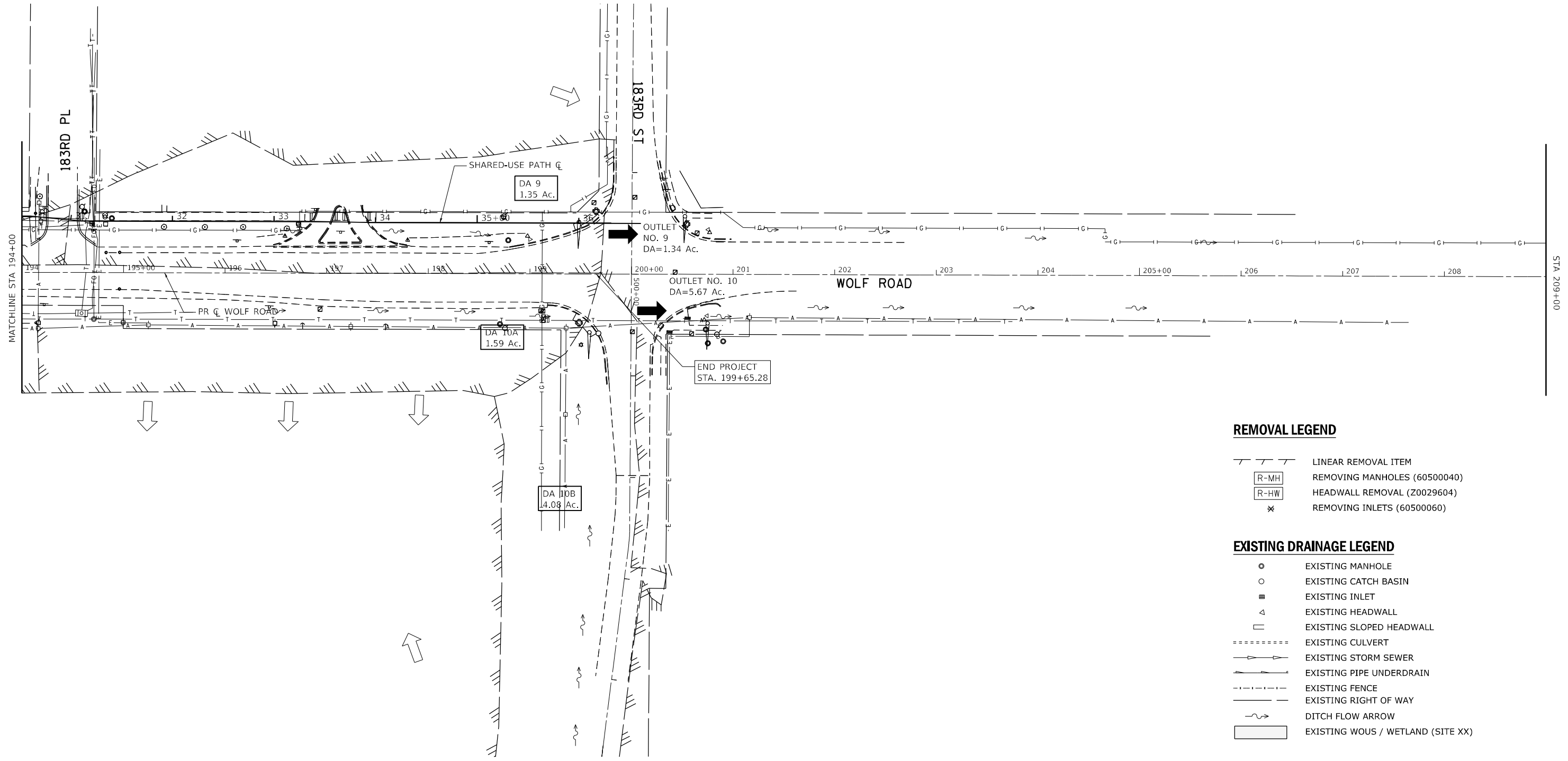

REMOVAL LEGEND

- LINEAR REMOVAL ITEM
- REMOVING MANHOLES (60500040)
- HEADWALL REMOVAL (Z0029604)
- REMOVING INLETS (60500060)

EXISTING DRAINAGE LEGEND

- EXISTING MANHOLE
- EXISTING CATCH BASIN
- EXISTING INLET
- EXISTING HEADWALL
- EXISTING SLOPED HEADWALL
- EXISTING CULVERT
- EXISTING STORM SEWER
- EXISTING PIPE UNDERDRAIN
- EXISTING FENCE
- EXISTING RIGHT OF WAY
- DITCH FLOW ARROW
- EXISTING WOUS / WETLAND (SITE XX)

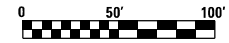

USER NAME = rmartin	DESIGNED - AA	REVISED -
DRAWN - AA	REVISIONS -	
PLOT SCALE = 100,0000' / in.	CHECKED - RSL	REVISED -
PLOT DATE = 2/2/2022	DATE - 07/07/2021	REVISED -

**STATE OF ILLINOIS
 DEPARTMENT OF TRANSPORTATION**

**DRAINAGE EXISTING AND REMOVAL PLAN
 WOLF ROAD BRIDGE OVER I-80**

SCALE: SHEET OF SHEETS STA. TO STA.

F.A.P. RTE. 2688	SECTION 2020-250-BY	COUNTY WILL	TOTAL SHEETS 133	SHEET NO. 42
CONTRACT NO. 62N20				
ILLINOIS FED. AID PROJECT				

PLAN	SURVEYED	DATE
	PLOTTED	BY
	ALIGNMENT CHECKED	
	CADD FILE NAME	
	NO.	

PROFILE	SURVEYED	DATE
	PLOTTED	BY
	GRADES CHECKED	
	STRUCTURE NOTATIONS CHECKED	
	NO.	

MODEL: Default
 FILE NAME: p:\projects\2020\20200025\00 - I-80 Phase II Vertical Design\20200025.dwg - Wolf Road over I-80 Drawings\Current Drawing Files\CADD_Sheets\Drainage\0113233-sh-drainage-01.dwg

DRAINAGE PLAN LEGEND

- | | | | | | | | | | |
|--|-----------------------------|--|---------------------------|--|----------|--|----------|--|--------------------------------|
| | EXISTING DRAINAGE OUTLET | | WATERS OF THE U.S. (WOUS) | | EXISTING | | PROPOSED | | STORM SEWER |
| | SUMMIT | | WETLAND | | | | | | PIPE UNDERDRAINS/TRENCH DRAINS |
| | DITCH FLOW ARROW | | FEMA FLOODWAY | | | | | | CULVERT |
| | SWALE FLOW ARROW | | FEMA FLOODPLAIN | | | | | | HEADWALL/SLOPED HEADWALL |
| | SHEET FLOW ARROW | | PR AGGREGATE SURFACE | | | | | | CATCH BASIN |
| | PROPOSED DRAINAGE STRUCTURE | | | | | | | | MANHOLE |
| | PROPOSED STORM SEWER | | | | | | | | INLET |

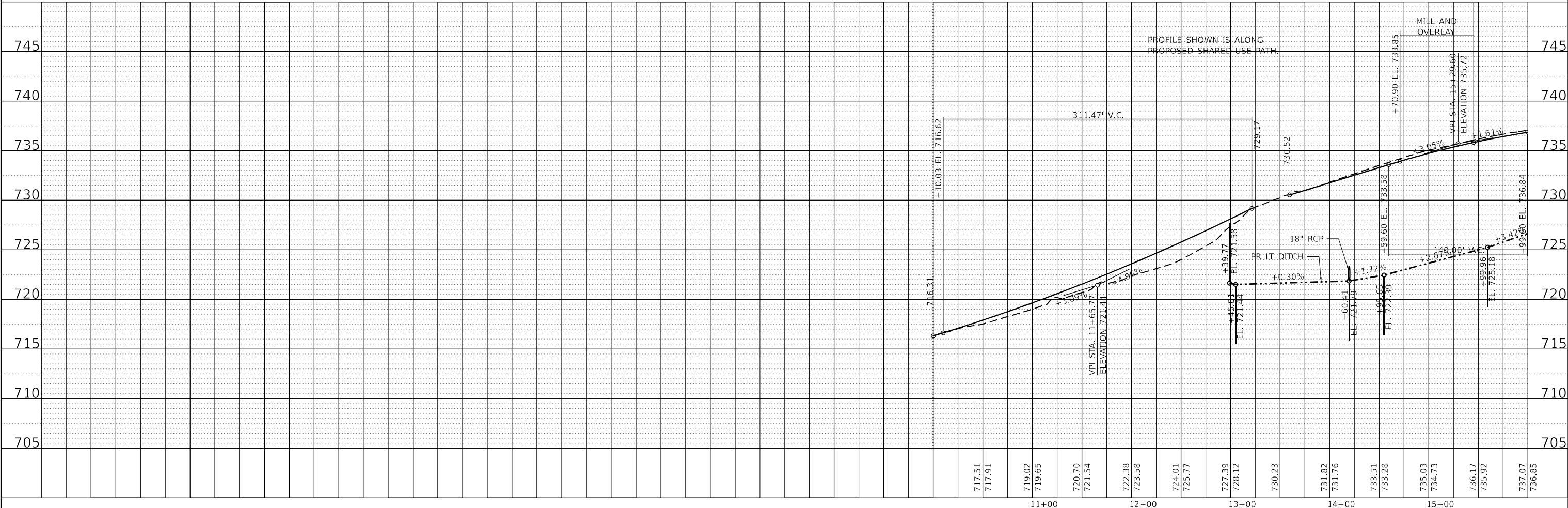
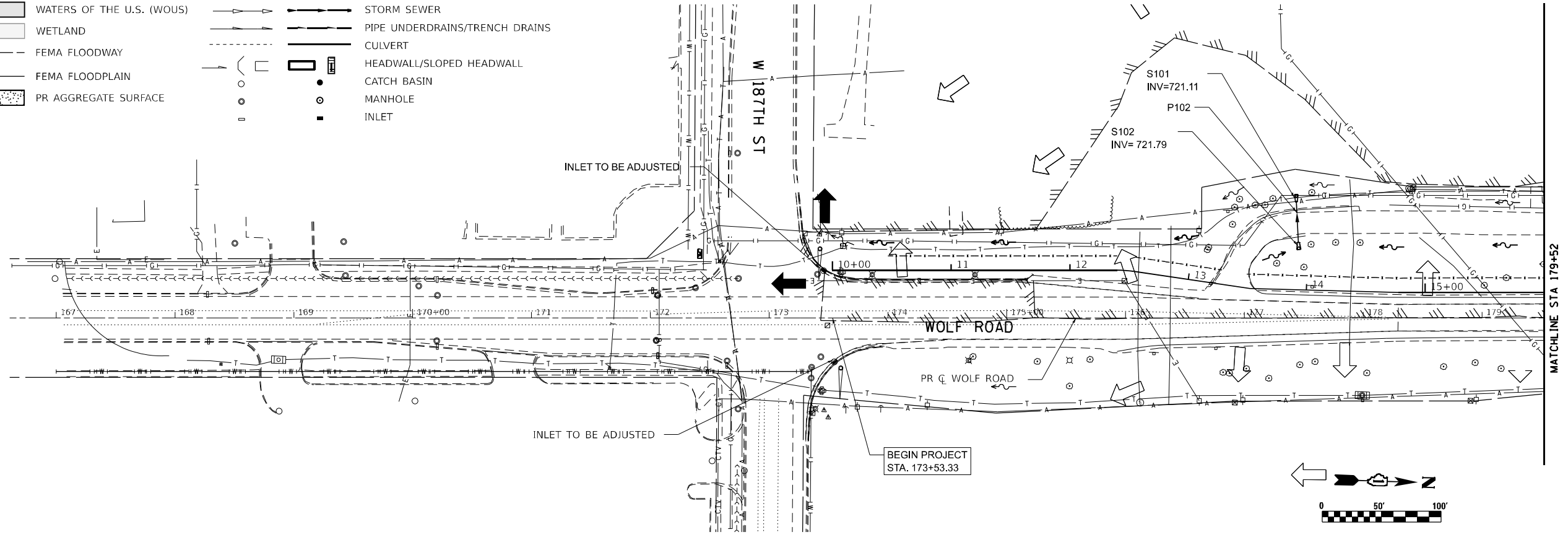

	USER NAME = r.vanderdus	DESIGNED - AA	REVISED -	STATE OF ILLINOIS DEPARTMENT OF TRANSPORTATION	PROPOSED DRAINAGE PLAN AND PROFILE WOLF ROAD BRIDGE OVER I-80			F.A.I. RTE.	SECTION	COUNTY	TOTAL SHEETS	SHEET NO.
	PLOT SCALE = 100,0000' / in.	CHECKED - RSL	REVISED -		I-80	2019-008-BR	WILL	133	43			
	PLOT DATE = 3/10/2022	DATE - 07/07/2021	REVISED -		SCALE:	SHEET	OF	SHEETS	STA.	TO	STA.	ILLINOIS

PLAN	SURVEYED	DATE
	PLOTTED	
	ALIGNMENT CHECKED	
	NOTE BOOK	
	NO.	
	CADD FILE NAME	
	NO.	

PROFILE	SURVEYED	DATE
	PLOTTED	
	GRADES CHECKED	
	NOTE BOOK	
	NO.	
	STRUCTURE NOTATIONS	
	NO.	

MODEL: Default
 FILE NAME: p:\projects\2019\201900425\08 - I-80 Phase II Vertical Design\201900425\01 - Wolf Road over I-80\Drawings\Current Drawing Files\CADD_Sheets\Drainage\01133233-sh-drainage\01133233-sh-drainage.dwg

DRAINAGE PLAN LEGEND

- ➔ EXISTING DRAINAGE OUTLET
- ⬆ SUMMIT
- ➔ DITCH FLOW ARROW
- ➔ SWALE FLOW ARROW
- ➔ SHEET FLOW ARROW
- 101 PROPOSED DRAINAGE STRUCTURE
- P101 PROPOSED STORM SEWER
- WATERS OF THE U.S. (WOUS)
- WETLAND
- FEMA FLOODWAY
- FEMA FLOODPLAIN
- PR AGGREGATE SURFACE
- EXISTING STORM SEWER
- PROPOSED STORM SEWER
- PIPE UNDERDRAINS/TRENCH DRAINS
- CULVERT
- HEADWALL/SLOPED HEADWALL
- CATCH BASIN
- MANHOLE
- INLET

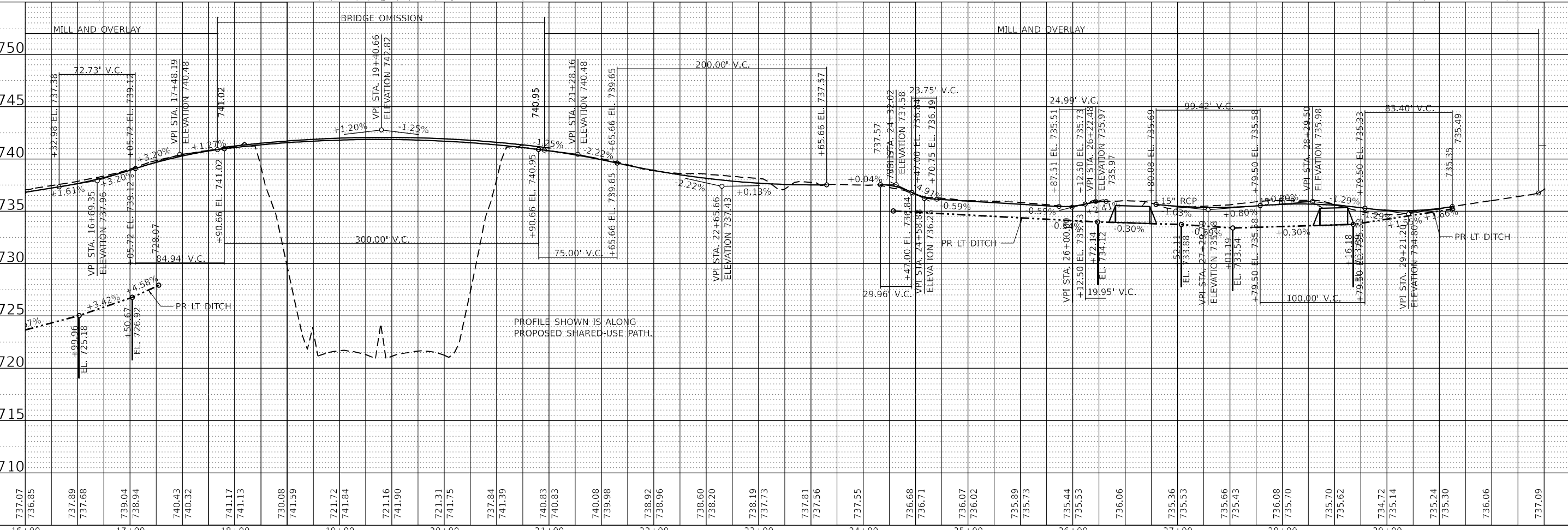
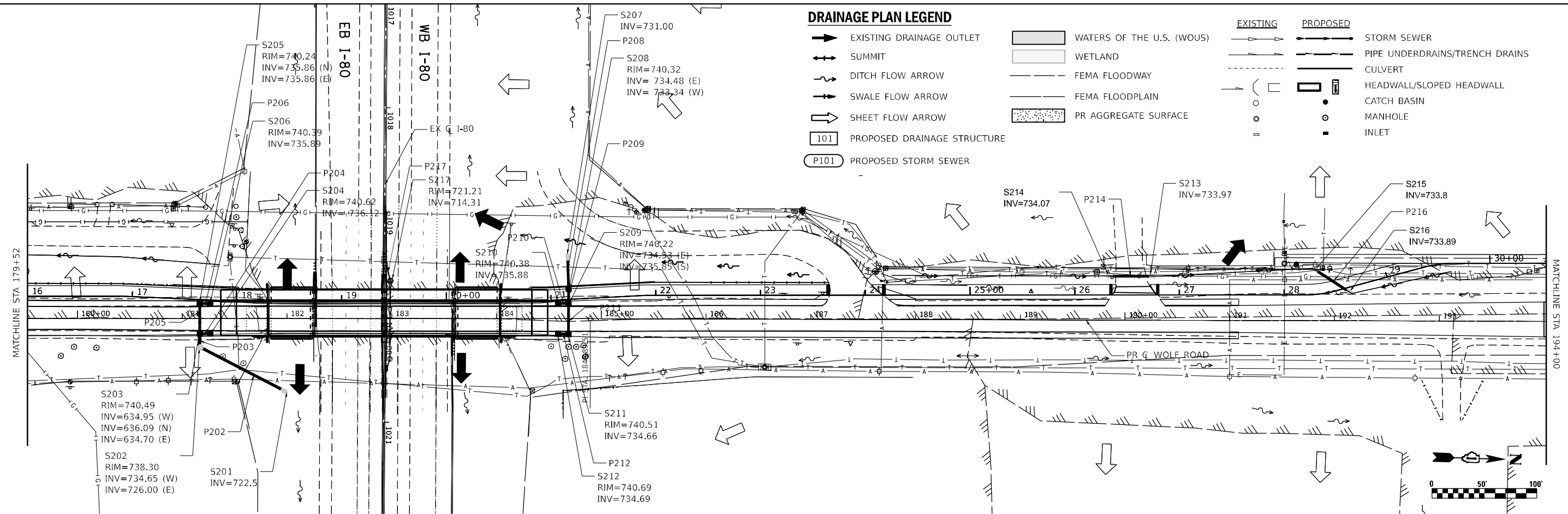

PROFILE SHOWN IS ALONG PROPOSED SHARED-USE PATH.

	USER NAME = rvandermus	DESIGNED - AA	REVISED -	STATE OF ILLINOIS DEPARTMENT OF TRANSPORTATION	PROPOSED DRAINAGE PLAN AND PROFILE WOLF ROAD BRIDGE OVER I-80			F.A.I. R.T.E.	SECTION	COUNTY	TOTAL SHEETS	SHEET NO.
	PLOT SCALE = 100,0000' / in.	CHECKED - RSL	REVISED -					I-80	2019-008-BR	WILL	133	44
	PLOT DATE = 3/10/2022	DATE - 07/07/2021	REVISED -					CONTRACT NO. 62N20				

SCALE: SHEET OF SHEETS STA. TO STA. ILLINOIS FED. AID PROJECT

PLAN	SURVEYED	DATE
	PLOTTED	
	ALIGNMENT CHECKED	
	NOTE BOOK	
	NO.	
	CADD FILE NAME	
	NO.	

PROFILE	SURVEYED	DATE
	PLOTTED	
	GRADES CHECKED	
	NOTE BOOK	
	NO.	
	STRUCTURE NOTATIONS CHKD	
	NO.	

MODEL: Default
 FILE NAME: p:\p\prime-pw\utility.com\p\inter-spw-0\Documents\01\Projects\2020\20200425\08 - I-80 Phase II\Various Design\20200425\01-WO 1-3 - Wolf Road over I-80\Drawings\Current Drawing Files\CADD_Sheets\Drainage\0113233-in-drainage-03.dgn

DRAINAGE PLAN LEGEND

- ➔ EXISTING DRAINAGE OUTLET
- ↕ SUMMIT
- ↘ DITCH FLOW ARROW
- ↙ SWALE FLOW ARROW
- ➔ SHEET FLOW ARROW
- 101 PROPOSED DRAINAGE STRUCTURE
- P101 PROPOSED STORM SEWER
- WATERS OF THE U.S. (WOUS)
- WETLAND
- FEMA FLOODWAY
- FEMA FLOODPLAIN
- PR AGGREGATE SURFACE
- EXISTING STORM SEWER
- PROPOSED STORM SEWER
- PIPE UNDERDRAINS/TRENCH DRAINS
- CULVERT
- HEADWALL/SLOPED HEADWALL
- CATCH BASIN
- MANHOLE
- INLET

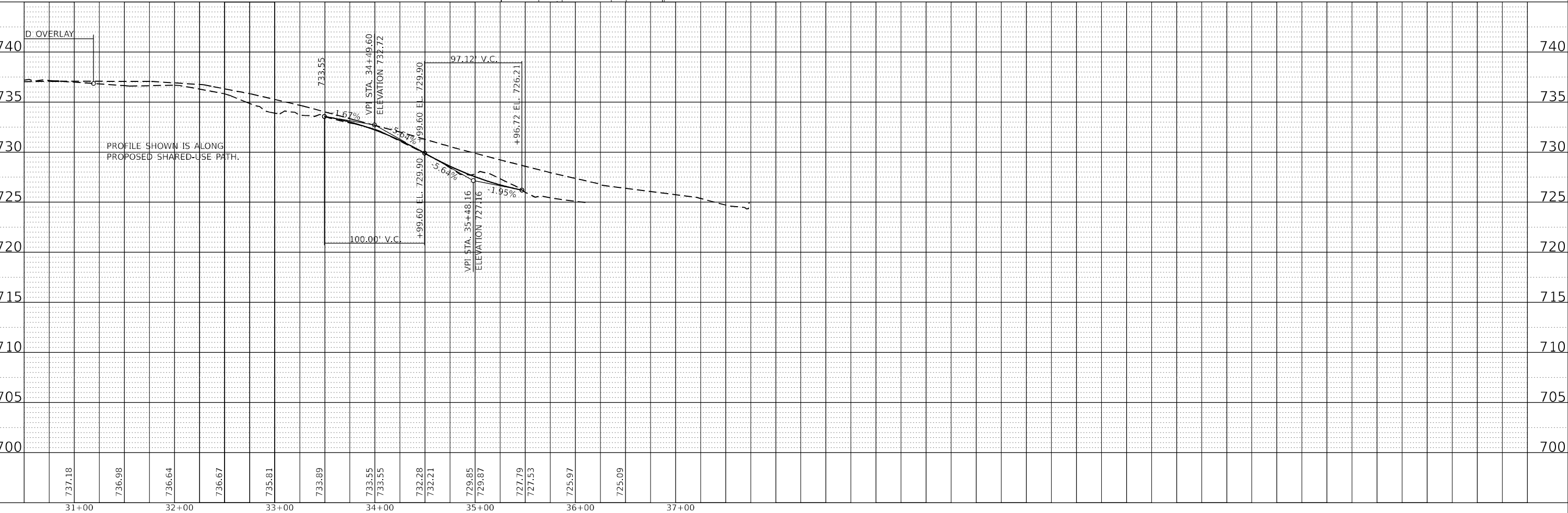
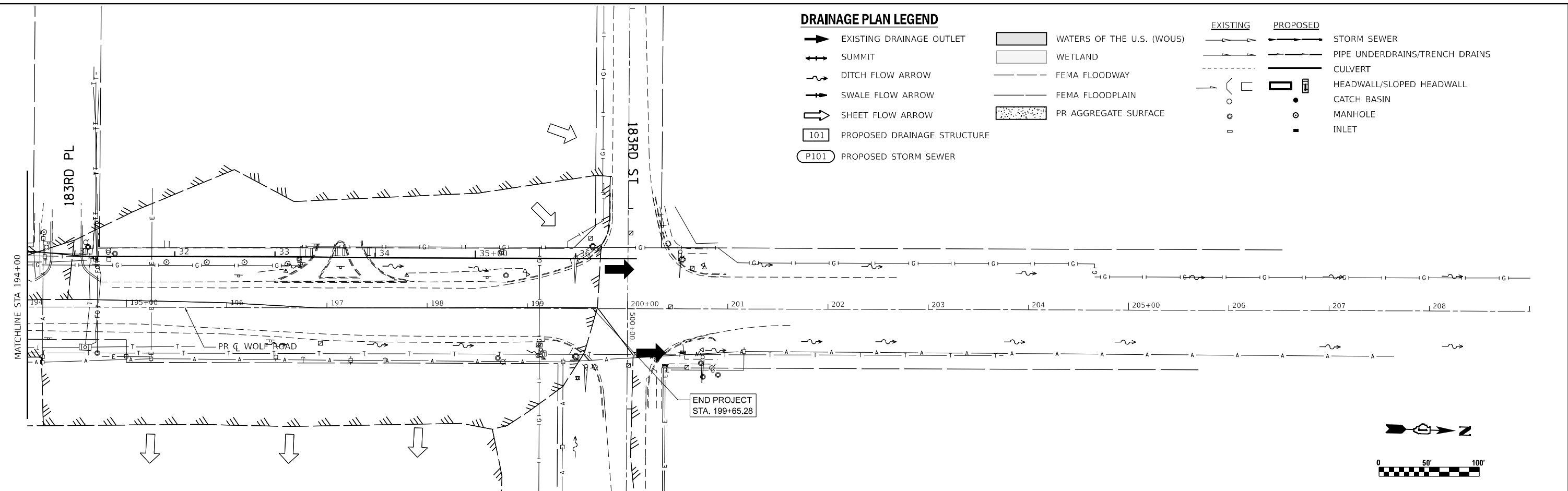

USER NAME = rvandemus	DESIGNED - AA	REVISED -
	DRAWN - AA	REVISED -
PLOT SCALE = 100,000' / in.	CHECKED - RSL	REVISED -
PLOT DATE = 3/10/2022	DATE - 07/07/2021	REVISED -

**STATE OF ILLINOIS
DEPARTMENT OF TRANSPORTATION**

**PROPOSED DRAINAGE PLAN AND PROFILE
WOLF ROAD BRIDGE OVER I-80**

SCALE: SHEET OF SHEETS STA. TO STA.

F.A.I. RTE.	SECTION	COUNTY	TOTAL SHEETS	SHEET NO.
I-80	2019-008-BR	WILL	133	45
CONTRACT NO. 62N20				
ILLINOIS		FED. AID PROJECT		

PROPOSED DRAINAGE STRUCTURE AND HEADWALL TABLE

SHEET	STRUCT. NO.	ALIGNMENT	STATION	OFFSET	TYPE	FRAME AND GRATE OR LID	PAY ITEM NO	RIM ELEV	INVERT ELEVATIONS			
									NORTH	SOUTH	EAST	WEST
PDP-1	101	WOLF RD	177+43	97.8 LT	PRC FLAR END SEC 18	--	421366301	--	--	--	--	721.11
PDP-1	102	WOLF RD	177+45	63.6 LT	PRC FLAR END SEC 18	--	421366301	--	--	--	721.79	--
PDP-2	201	WOLF RD	181+93	66.7 LT	PRC FLAR END SEC 18	--	421366301	--	--	--	722.50	--
PDP-2	202	WOLF RD	181+18	26.6 RT	MAN TA 4 DIA	T1F CL	60218400	738.30	--	--	726.00	734.65
PDP-2	203	WOLF RD	181+17	14.3 RT	CB TA 4 DIA	T20F&G	60201310	740.49	--	--	634.70	634.95
PDP-2	204	WOLF RD	181+27	14.2 RT	CB TA 4 DIA	T20F&G	60201310	740.62	--	736.12	--	--
PDP-2	205	WOLF RD	181+17	14.4 LT	CB TA 4 DIA	T20F&G	60201310	740.24	735.86	--	735.86	--
PDP-2	206	WOLF RD	181+27	14.2 LT	CB TA 4 DIA	T20F&G	60201310	740.39	--	735.89	--	--
PDP-2	207	WOLF RD	184+68	54.8 LT	PRC FLAR END SEC 15	--	54213660	--	--	--	--	731.00
PDP-2	208	WOLF RD	184+69	28.4 LT	CB TA 4 DIA	T20F&G	60201310	740.32	--	--	734.48	733.34
PDP-2	209	WOLF RD	184+69	14.7 LT	CB TA 4 DIA	T20F&G	60201310	740.22	--	735.85	734.53	--
PDP-2	210	WOLF RD	184+59	14.3 LT	CB TA 4 DIA	T20F&G	60201310	740.38	735.88	--	--	--
PDP-2	211	WOLF RD	184+69	14.7 RT	CB TA 4 DIA	T20F&G	60201310	740.51	734.66	--	--	--
PDP-2	212	WOLF RD	184+59	14.4 RT	CB TA 4 DIA	T20F&G	60201310	740.69	734.69	--	--	--
PDP-2	213	WOLF RD	190+22	42.0 LT	PRC FLAR END SEC 15	--	54213660	--	733.97	--	--	--
PDP-2	214	WOLF RD	189+89	42.0 LT	PRC FLAR END SEC 15	--	54213660	--	--	734.07	--	--
PDP-2	215	WOLF RD	191+84	46.5 LT	PRC FLAR END SEC 15	--	54213660	--	--	733.80	--	--
PDP-2	216	WOLF RD	192+11	29.6 LT	PRC FLAR END SEC 15	--	54213660	--	734.00	--	--	--
PDP-2	217	I-80	1019+66	6.7 LT	MAN TA 5 DIA	T1F CL	60221100	721.21	714.31	--	714.31	--

PROPOSED DRAINAGE PIPE TABLE

SHEET	PIPE NO.	STRUCTURE		DESCRIPTION	(IN)	PAY ITEM	LENGTH (FOOT)	SLOPE (%)	TBF (CY)
		FROM	TO						
PDP-1	102	102	101	STORM SEW CL A 1 18	18	550A0090	34	2.00	34.0
PDP-2	202	202	201	STORM SEW CL A 1 18	18	550A0090	86	4.10	--
PDP-2	203	203	202	STORM SEW CL A 1 18	18	550A0090	13	0.40	13.0
PDP-2	204	204	203	STORM SEW CL A 1 15	15	550A0070	10	0.30	10.0
PDP-2	205	205	203	STORM SEW CL A 1 15	15	550A0070	29	3.10	29.0
PDP-2	206	206	205	STORM SEW CL A 1 15	15	550A0070	10	0.30	10.0
PDP-2	208	208	207	STORM SEW CL A 1 15	15	550A0070	26	9.20	10.0
PDP-2	209	209	208	STORM SEW CL A 1 15	15	550A0070	14	0.40	14.0
PDP-2	210	210	209	STORM SEW CL A 1 15	15	550A0070	10	0.30	10.0
PDP-2	211	211	209	STORM SEW CL A 1 15	15	550A0070	29	0.40	29.0
PDP-2	212	212	211	STORM SEW CL A 1 15	15	550A0070	10	0.30	10.0
PDP-2	214	214	213	STORM SEW CL A 1 15	15	550A0070	33	0.31	33.0
PDP-2	216	216	215	STORM SEW CL A 1 15	15	550A0070	31	0.64	26.0
PDP-2	217	EX 443MH	217	STORM SEW CL A 1 24	24	550A0120	17	0.22	13.6

DRAINAGE PIPE REMOVAL TABLE

SHEET	ALIGNMENT	FROM		TO		55100500 STORM SEWER REMOVAL 12" FOOT	55101200 STORM SEWER REMOVAL 24" FOOT	55100500 TRENCH BACKFILL CY
		STATION	OFFSET	STATION	OFFSET			
PDP-2	WOLF ROAD	189+83	29.32 LT	190+33	29.16 LT	50	-	12.5
PDP-2	I-80	1019+50	1.3 LT	1019+66	6.7 LT	-	17	20.4

DRAINAGE STRUCTURE REMOVAL AND ADJUSTEMENT TABLE

SHEET	ALIGNMENT	STATION	OFFSET	60500060 REMOVING INLETS EACH	Z0029604 HEADWALL REMOVAL EACH	60260100 INLETS TO BE ADJUSTED EACH	60500040 REMOVING MANHOLES EACH
PDP-1	WOLF RD	173+45	39.35 LT	-	-	1	-
PDP-1	WOLF RD	173+54	35.80 RT	-	-	1	-
PDP-1	WOLF RD	177+46	52.78 LT	-	1	-	-
PDP-1	WOLF RD	1774+32	106.88 LT	-	1	-	-
PDP-2	WOLF RD	181+91	13.9 LT	1	-	-	-
PDP-2	WOLF RD	182+01	13.9 LT	1	-	-	-
PDP-2	WOLF RD	182+11	13.9 LT	1	-	-	-
PDP-2	WOLF RD	182+21	13.9 LT	1	-	-	-
PDP-2	WOLF RD	181+91	13.5 RT	1	-	-	-
PDP-2	WOLF RD	182+01	13.5 RT	1	-	-	-
PDP-2	WOLF RD	182+11	13.5 RT	1	-	-	-
PDP-2	WOLF RD	182+21	13.5 RT	1	-	-	-
PDP-2	WOLF RD	183+68	14.2 LT	1	-	-	-
PDP-2	WOLF RD	183+78	14.2 LT	1	-	-	-
PDP-2	WOLF RD	183+88	14.2 LT	1	-	-	-
PDP-2	WOLF RD	183+98	14.2 LT	1	-	-	-
PDP-2	WOLF RD	183+68	13.2 RT	1	-	-	-
PDP-2	WOLF RD	183+78	13.2 RT	1	-	-	-
PDP-2	WOLF RD	183+88	13.2 RT	1	-	-	-
PDP-2	WOLF RD	183+98	13.2 RT	1	-	-	-
PDP-2	WOLF RD	189+83	29.32 LT	-	1	-	-
PDP-2	WOLF RD	190+33	29.16 LT	-	1	-	-
PDP-2	I-80	1019+66	6.74 LT	-	-	-	1

MODEL: Default
 FILE NAME: p:\projects\2020\20200425_00 - IDOT Phase II Variable Design\Drawings\Current_Drawing_Files\CADD_Sheets\Drainage\0112333-ent-DrSchedule.dgn
 PROJECT: 2020\20200425_00 - IDOT Phase II Variable Design\Drawings\Current_Drawing_Files\CADD_Sheets\Drainage\0112333-ent-DrSchedule.dgn
 USER: rmarlin
 DESIGNED: AA
 DRAWN: AA
 CHECKED: RSL
 DATE: 07/07/2021
 PLOT SCALE: 2,0000 ' / in.
 PLOT DATE: 2/2/2022

STATE OF ILLINOIS
DEPARTMENT OF TRANSPORTATION

DRAINAGE SCHEDULE
WOLF ROAD BRIDGE OVER I-80

SCALE: SHEET OF SHEETS STA. TO STA.

F.A.P. RTE.	SECTION	COUNTY	TOTAL SHEETS	SHEET NO.
2688	2020-250-BY	WILL	133	46
CONTRACT NO. 62N20				
ILLINOIS FED. AID PROJECT				

TRAFFIC SIGNAL LEGEND

(NOT TO SCALE)

ITEM	EXISTING	PROPOSED	ITEM	EXISTING	PROPOSED	ITEM	EXISTING	PROPOSED
CONTROLLER CABINET			HANDHOLE -SQUARE -ROUND	 	 	SIGNAL HEAD -(P) PROGRAMMABLE SIGNAL HEAD		
COMMUNICATION CABINET			HEAVY DUTY HANDHOLE -SQUARE -ROUND	 	 	SIGNAL HEAD WITH BACKPLATE -(P) PROGRAMMABLE SIGNAL HEAD -(RB) RETROREFLECTIVE BACKPLATE		
MASTER CONTROLLER			DOUBLE HANDHOLE			PEDESTRIAN SIGNAL HEAD AT RAILROAD INTERSECTIONS		
MASTER MASTER CONTROLLER			JUNCTION BOX			PEDESTRIAN SIGNAL HEAD WITH COUNTDOWN TIMER		
UNINTERRUPTABLE POWER SUPPLY			RAILROAD CANTILEVER MAST ARM			ILLUMINATED SIGN "NO LEFT TURN"/"NO RIGHT TURN"		
SERVICE INSTALLATION -(P) POLE MOUNTED			RAILROAD FLASHING SIGNAL			NUMBER OF CONDUCTORS, ELECTRIC CABLE NO. 14, UNLESS NOTED OTHERWISE. ALL DETECTOR LOOP CABLE TO BE SHIELDED		
SERVICE INSTALLATION -(G) GROUND MOUNTED -(GM) GROUND MOUNTED METERED	 	 	RAILROAD CROSSING GATE			GROUND CABLE IN CONDUIT, NO. 6 SOLID COPPER (GREEN)		
TELEPHONE CONNECTION			RAILROAD CROSSBUCK			ELECTRIC CABLE IN CONDUIT, TRACER NO. 14 1/C		
STEEL MAST ARM ASSEMBLY AND POLE			RAILROAD CONTROLLER CABINET			COAXIAL CABLE		
ALUMINUM MAST ARM ASSEMBLY AND POLE			UNDERGROUND CONDUIT (UC), GALVANIZED STEEL			VENDOR CABLE		
STEEL COMBINATION MAST ARM ASSEMBLY AND POLE WITH LUMINAIRE			TEMPORARY SPAN WIRE, TETHER WIRE, AND CABLE			COPPER INTERCONNECT CABLE, NO. 18, 3 PAIR TWISTED, SHIELDED		
SIGNAL POST -(BM) BARREL MOUNTED - TEMPORARY			SYSTEM ITEM	S	SP	FIBER OPTIC CABLE -NO. 62.5/125, MM12F -NO. 62.5/125, MM12F SM12F -NO. 62.5/125, MM12F SM24F		
WOOD POLE			INTERSECTION ITEM	I	IP	GROUND ROD -(C) CONTROLLER -(M) MAST ARM -(P) POST -(S) SERVICE		
GUY WIRE			REMOVE ITEM		R			
SIGNAL HEAD			RELOCATE ITEM		RL			
SIGNAL HEAD WITH BACKPLATE			ABANDON ITEM		A			
SIGNAL HEAD OPTICALLY PROGRAMMED			CONTROLLER CABINET AND FOUNDATION TO BE REMOVED		RCF			
FLASHER INSTALLATION -(FS) SOLAR POWERED	 	 	MAST ARM POLE AND FOUNDATION TO BE REMOVED		RMF			
PEDESTRIAN SIGNAL HEAD			SIGNAL POST AND FOUNDATION TO BE REMOVED		RPF			
PEDESTRIAN PUSH BUTTON -(APS) ACCESSIBLE PEDESTRIAN PUSH BUTTON			DETECTOR LOOP, TYPE I					
RADAR DETECTION SENSOR			PREFORMED DETECTOR LOOP					
VIDEO DETECTION CAMERA			SAMPLING (SYSTEM) DETECTOR					
RADAR/VIDEO DETECTION ZONE			INTERSECTION AND SAMPLING (SYSTEM) DETECTOR					
PAN, TILT, ZOOM (PTZ) CAMERA			QUEUE AND SAMPLING (SYSTEM) DETECTOR					
EMERGENCY VEHICLE LIGHT DETECTOR			WIRELESS DETECTOR SENSOR					
CONFIRMATION BEACON			WIRELESS ACCESS POINT					
WIRELESS INTERCONNECT								
WIRELESS INTERCONNECT RADIO REPEATER								

TS SHT NO. 1

MODEL: P:\Info\... FILE NAME: S:\IP\Design\KCI\InHouse\Design\2019\CMAQ\Interconnect\Project\Contract\2161\SES3\rc\TLH\Review\CADD\with-Commissions\Symbol_12-20-19.dgn

USER NAME = bennettidw	DESIGNED - IP	REVISED -
	DRAWN - IP	REVISED -
PLOT SCALE = 50,0000 * / in.	CHECKED - LP	REVISED -
PLOT DATE = 1/20/2022	DATE - 9/29/2016	REVISED -

STATE OF ILLINOIS
DEPARTMENT OF TRANSPORTATION

DISTRICT ONE
STANDARD TRAFFIC SIGNAL DESIGN DETAILS

SCALE: NONE SHEET 1 OF 7 SHEETS STA. TO STA.

F.A. RTE.	SECTION	COUNTY	TOTAL SHEETS	SHEET NO.
2688	2020-250-BY	COOK & WILL	133	47
TS-05		CONTRACT NO. 62N20		
ILLINOIS FED. AID PROJECT				

LOOP DETECTOR NOTES

1. EACH PAIR OF LOOP WIRES SHALL BE PLACED IN A SEPARATE EMPTY COILABLE NONMETALLIC CONDUIT FROM THE EDGE OF PAVEMENT TO THE HANDHOLE. SPACING BETWEEN THE HOLES DRILLED IN THE PAVEMENT SHALL NOT BE LESS THAN 6" (150 mm). EMPTY COILABLE NONMETALLIC CONDUIT SHALL BE INCLUDED IN THE COST OF THE LOOP WIRE.
2. THE NUMBER OF LOOP TURNS SHALL BE AS RECOMMENDED BY THE AMPLIFIER MANUFACTURER. ALL ADJACENT SIDES OF THE LOOPS SHALL BE INSTALLED IN SUCH A WAY THAT THE CURRENT FLOW IS IN THE SAME DIRECTION TO REINFORCE ITS MAGNETIC FIELDS FOR SMALL VEHICLE DETECTION.
3. EACH LOOP LEAD-IN SHALL BE IDENTIFIED AND PERMANENTLY TAGGED IN THE HANDHOLE. EACH LEAD-IN CABLE TAG SHALL INDICATE THE LOCATION OF THE LOOP, LOOP ROTATION (CLOCKWISE/COUNTERCLOCKWISE), LOOP LEAD-IN DIRECTION (IN OR OUT), LOOP CABLE NUMBER AND LOCATION IN CABINET, AND NUMBER OF TURNS IN THE DETECTOR LOOPS IN WATER PROOF INK AS INDICATED ON THE DISTRICT 1 STANDARD TRAFFIC SIGNAL DESIGN DETAIL. THE CONTRACTOR SHALL MARK LOOP LOCATIONS ON RECORD DRAWINGS AND PRESENT TO THE ENGINEER AFTER FINAL INSPECTION. LOOPS SHALL BE MARKED BY LANE AND LOOP NUMBER. SEE DETAIL BELOW.
4. ALL LOOP CABLE SHALL BE FASTENED WITH PLASTIC TIE WRAP TO THE HANDHOLE HOOKS.
5. IN ASPHALT PAVEMENT, LOOPS SHOULD BE PLACED IN THE BINDER AND DIVEHOLES MARKED AT THE CURB WITH A SAW-CUT. THE SAW-CUT SHALL BE CUT IN ACCORDANCE WITH LOCAL AND E.P.A. DUST CONTROL REQUIREMENTS. DETECTOR LOOP(S) SHALL NOT BE INSTALLED IN WET CONDITIONS AND THE SAW-CUTS MUST BE FREE OF DEBRIS AND RESIDUE SUCH AS DUST AND WATER WHICH IS TO BE ACHIEVED BY THE USE OF COMPRESSED AIR, WIRE BRUSHING AND HEAT DRYING ACCORDING TO SEALANT MANUFACTURER REQUIREMENTS. THE DETECTOR WIRE SHALL BE HELD IN PLACE BY THE USE OF FORM WEDGES. WEDGES SHALL BE SPACED NO MORE THAN 18" (450 mm) APART.
6. LOOP SPLICES SHALL BE SOLDERED USING A SOLDERING IRON. BLOW TORCHES OR OTHER DEVICES WHICH OXIDIZE COPPER CABLE SHALL NOT BE ALLOWED FOR SOLDERING OPERATIONS. SEE DETAIL BELOW RIGHT.
7. PREFORMED DETECTOR LOOPS SHALL BE USED, AS SHOWN ON THE PLANS, WHERE NEW CONCRETE PAVEMENT IS PROPOSED. THE INSTALLATION OF PREFORMED LOOPS SHALL BE IN ACCORDANCE WITH THE DISTRICT 1 SPECIFICATIONS OR AS DIRECTED BY THE ENGINEER.

LOOP LEAD-IN CABLE TAG

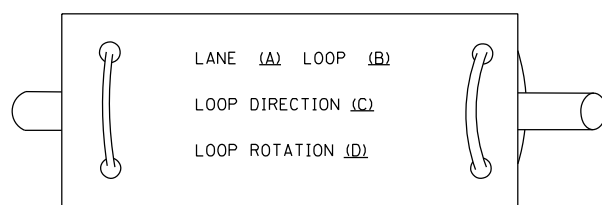

- A. LANE 1 IS THE LANE CLOSEST TO THE CENTERLINE OF THE ROADWAY
- B. LOOP #1 IS THE LOOP IN THE LANE CLOSEST TO THE INTERSECTION.
- C. LABEL LOOP CABLE "IN" OR LOOP CABLE "OUT".
- D. LABEL LOOP CABLE CLOCKWISE OR LOOP CABLE COUNTERCLOCKWISE.

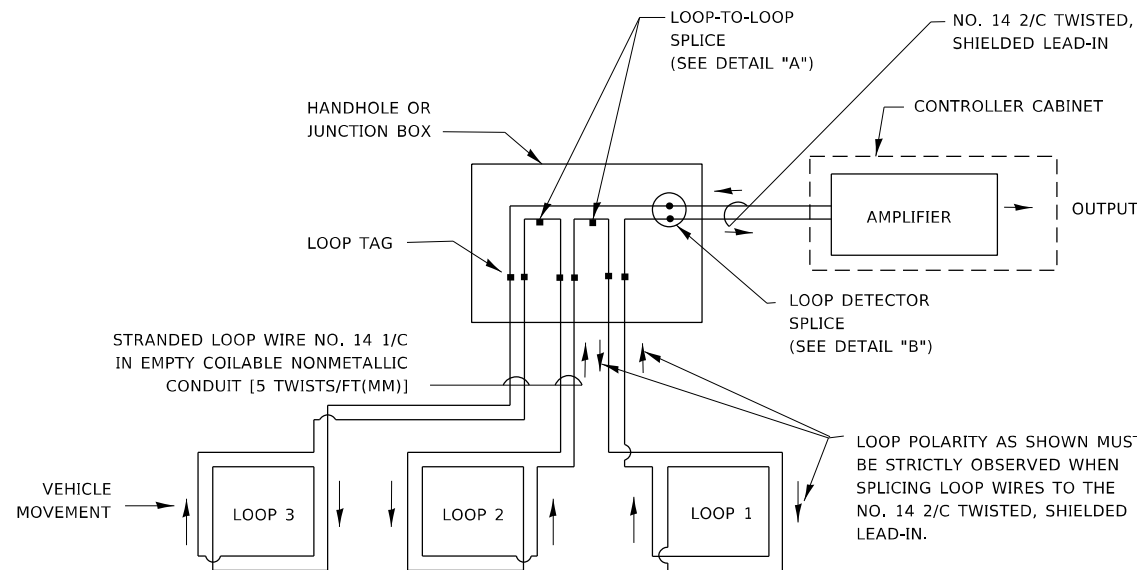

DETECTOR LOOP WIRING SCHEMATIC

- LOOPS SHALL BE SPLICED IN SERIES. SAW-CUTS SHALL BE A MINIMUM WIDTH OF 5/16" (8 mm).
- SAW-CUT DEPTHS SHALL BE 3" (75 mm), IF IN CONCRETE.
- THE SAW-CUT DEPTH SHALL BE TO THE TOP OF THE REINFORCEMENT.
- LOOP CORNERS SHALL BE DRILLED WITH A 2" (50 mm) DIAMETER CORE.

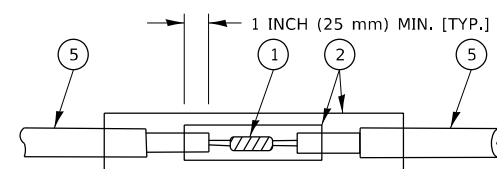

DETAIL "A"
LOOP-TO-LOOP SPLICE

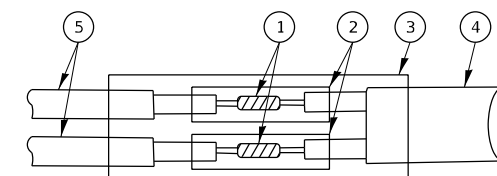

DETAIL "B"
LOOP-TO-CONTROLLER SPLICE

TYPE I LOOP

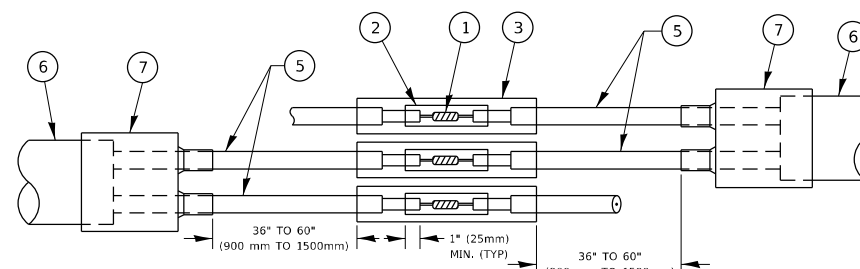

DETAIL "A"
LOOP-TO-LOOP SPLICE

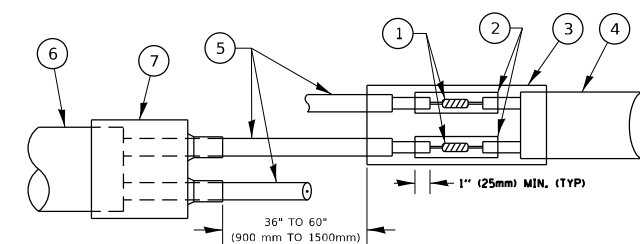

DETAIL "B"
LOOP-TO-CONTROLLER SPLICE

PREFORMED LOOP

LOOP DETECTOR SPLICE

- 1 WESTERN UNION SPLICE SOLDERED WITH ROSIN CORE FLUX. ALL EXPOSED SURFACES OF THE SOLDER SHALL BE SMOOTH. THE WESTERN UNION SPLICES SHALL BE STAGGERED.
- 2 WCSMW 30/100 HEAT SHRINK TUBE, MINIMUM LENGTH 3" (75 mm), UNDERWATER GRADE.
- 3 WCS 200/750 HEAT SHRINK TUBE, MINIMUM LENGTH 6" (150 mm), UNDERWATER GRADE.
- 4 NO. 14 2/C TWISTED, SHIELDED CABLE.
- 5 LOOP CONDUCTOR WITH FLEXIBLE PLASTIC TUBE. PREFORMED LOOP
- 6 XL POLYOLEFIN 2 CONDUCTOR
- 7 BREAKOUT SEALS, TYCO CBR-2 OR APPROVED EQUAL

TS SHT NO. 2

MODEL: Default; FILE: NAME: S:\IP\Design\K\In\Hous-Design\2019-CMAQ\Interconnect-Project\Contract-621861-SE3-Proc-4-TH-Review-CADD-with-Commissions\Symbol_12-20-19.dgn

USER NAME = bennettidw	DESIGNED -	REVISED -
	DRAWN -	REVISED -
PLOT SCALE = 50,0000 * / in.	CHECKED -	REVISED -
PLOT DATE = 1/20/2022	DATE -	REVISED -

**STATE OF ILLINOIS
DEPARTMENT OF TRANSPORTATION**

**DISTRICT ONE
STANDARD TRAFFIC SIGNAL DESIGN DETAILS**

SCALE: NONE SHEET 2 OF 7 SHEETS STA. TO STA.

F.A. RTE.	SECTION	COUNTY	TOTAL SHEETS	SHEET NO.
2688	2020-250-BY	COOK & WILL	133	48
TS-05		CONTRACT NO. 62N20		
ILLINOIS		FED. AID PROJECT		

TRAFFIC SIGNAL MAST ARM AND SIGNAL POST

MAST ARM MOUNTED SIGNALS IN EXISTING, PROPOSED OR FUTURE SIDEWALK/BICYCLE PATH AREA. INTERSECTION SHOWN WITH PEDESTRIAN SIGNALS AND PEDESTRIAN PUSHBUTTON DETECTORS.

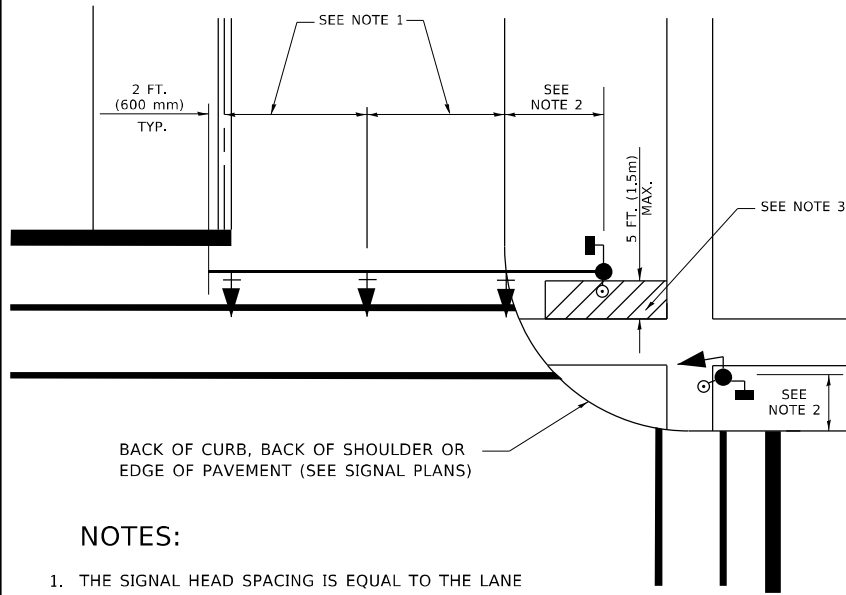

BACK OF CURB, BACK OF SHOULDER OR EDGE OF PAVEMENT (SEE SIGNAL PLANS)

NOTES:

1. THE SIGNAL HEAD SPACING IS EQUAL TO THE LANE WIDTH OR AS SHOWN ON THE TRAFFIC SIGNAL PLAN.
2. REFER TO THE TRAFFIC SIGNAL EQUIPMENT OFFSET TABLE.
3. PROVIDE A LEVEL ALL-WEATHER SURFACE (CONCRETE SIDEWALK, ASPHALT BICYCLE PATH SURFACE OR MATCHING MATERIAL TO THE ADJACENT SURFACE) UP TO THE MAST ARM SHAFT OR THE SIGNAL POST.
4. THE FACE OF THE PEDESTRIAN PUSHBUTTON SHALL BE PARALLEL TO THE CROSSWALK TO BE USED.
5. THE LOCATIONS AND INSTALLATION OF PEDESTRIAN SIGNAL HEADS AND PEDESTRIAN PUSHBUTTONS SHALL MEET THE REQUIREMENTS OF THE MUTCD AND INFORMATION FOUND IN THE "AMERICANS WITH DISABILITIES ACT ACCESSIBILITY GUIDELINES FOR BUILDINGS AND FACILITIES."

PEDESTRIAN SIGNAL POST AND PEDESTRIAN PUSH BUTTON POST

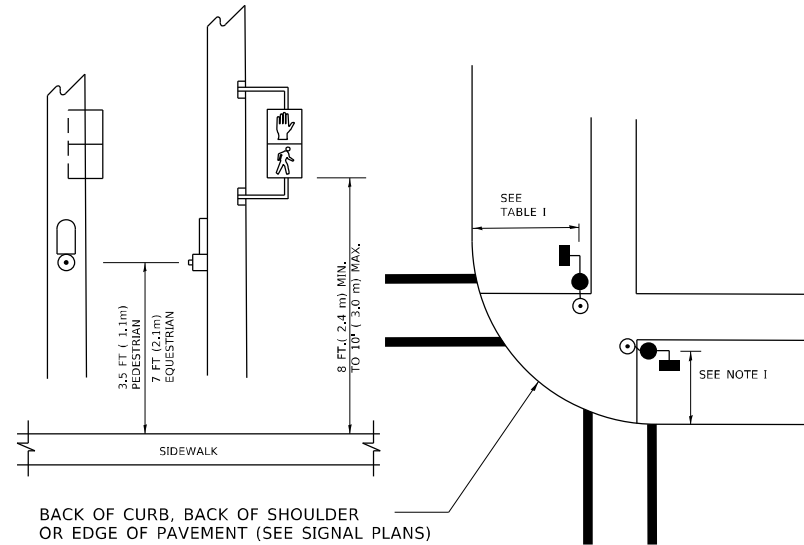

BACK OF CURB, BACK OF SHOULDER OR EDGE OF PAVEMENT (SEE SIGNAL PLANS)

NOTES:

1. REFER TO THE TRAFFIC SIGNAL EQUIPMENT OFFSET TABLE.
2. PROVIDE A LEVEL ALL-WEATHER SURFACE (CONCRETE SIDEWALK, ASPHALT BICYCLE PATH SURFACE OR MATCHING MATERIAL TO THE ADJACENT SURFACE) UP TO THE PEDESTRIAN SIGNAL POST OR THE PEDESTRIAN PUSH BUTTON POST.
3. THE FACE OF THE PEDESTRIAN PUSHBUTTON SHALL BE PARALLEL TO THE CROSSWALK TO BE USED.
4. THE LOCATIONS AND INSTALLATION OF PEDESTRIAN SIGNAL HEADS AND PEDESTRIAN PUSHBUTTONS SHALL MEET THE REQUIREMENTS OF THE MUTCD AND INFORMATION FOUND IN THE "AMERICANS WITH DISABILITIES ACT ACCESSIBILITY GUIDELINES FOR BUILDINGS AND FACILITIES."

RECOMMENDED PUSHBUTTON LOCATIONS

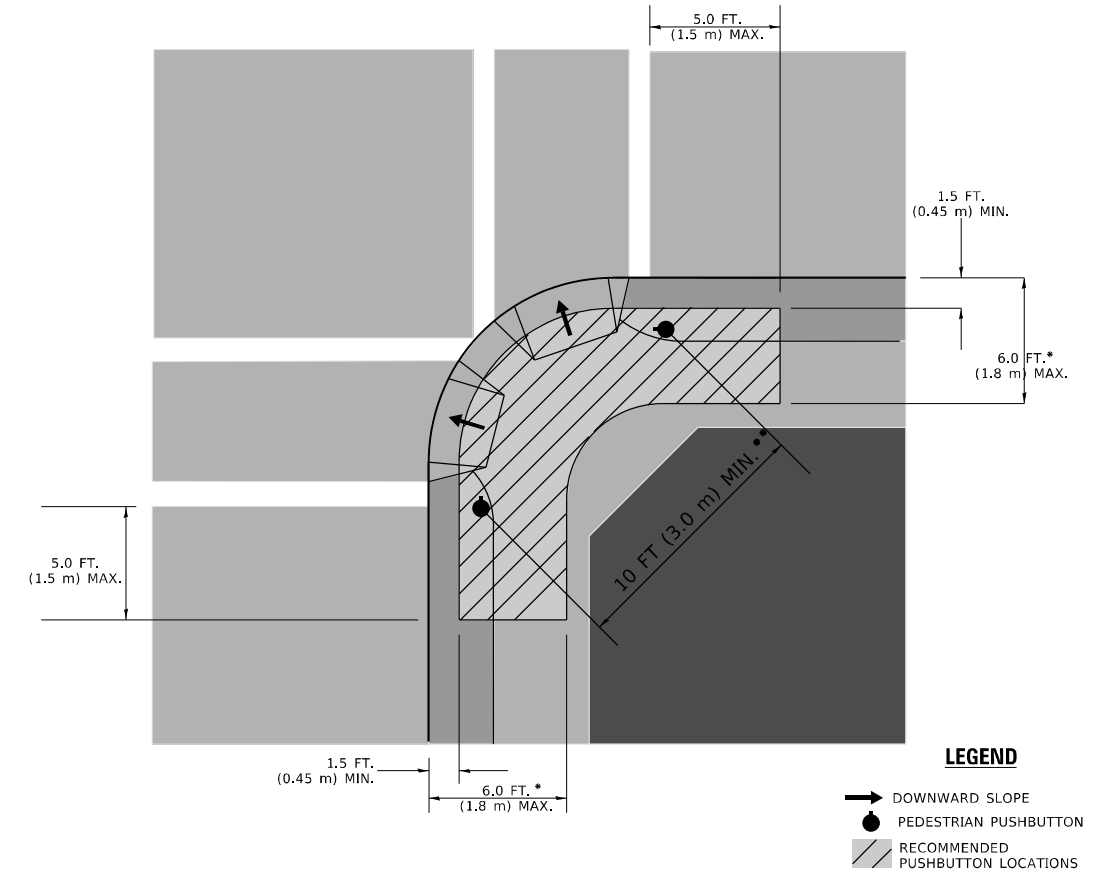

LEGEND

- DOWNWARD SLOPE
- PEDESTRIAN PUSHBUTTON
- ▨ RECOMMENDED PUSHBUTTON LOCATIONS

- * WHERE THERE ARE CONSTRAINTS THAT MAKE IT IMPRACTICAL TO PLACE THE PEDESTRIAN PUSHBUTTON BETWEEN 1.5 FT (0.45 m) AND 6 FT (1.8 m) FROM THE EDGE OF THE CURB, SHOULDER, OR PAVEMENT, IT SHOULD NOT BE FURTHER THAN 10 FT (3 m) FROM THE EDGE OF CURB, SHOULDER, OR PAVEMENT.
- ** WHERE THERE ARE CONSTRAINTS ON A PARTICULAR CORNER THAT MAKE IT IMPRACTICAL TO PROVIDE THE 10 FT (3 m) SEPERATION BETWEEN THE TWO PEDESTRIAN PUSHBUTTONS, THE PUSHBUTTONS MAY BE PLACED CLOSER TOGETHER OR ON THE SAME POLE.

NOTES:

1. PEDESTRIAN SIGNAL HEADS SHALL BE MOUNTED WITH THE BOTTOM OF THE SIGNAL HOUSING INCLUDING BRACKETS NOT LESS THAN 8 FT (2.4 m) OR MORE THAN 10 FT (3 m) ABOVE SIDEWALK LEVEL, AND SHALL BE POSITIONED AND ADJUSTED TO PROVIDE MAXIMUM VISIBILITY AT THE BEGINNING OF THE CONTROLLED CROSSWALK.
2. THE BOTTOM OF THE SIGNAL HOUSING (INCLUDING BRACKETS) OF A VEHICULAR SIGNAL FACE THAT IS NOT LOCATED OVER A HIGHWAY SHALL BE AT LEAST 8 FT (2.4 m) BUT NOT MORE THAN 19 FT (5.8 m) ABOVE THE SIDEWALK OR, IF THERE IS NO SIDEWALK, ABOVE THE PAVEMENT GRADE AT THE CENTER OF THE ROADWAY.
3. THE BOTTOM OF THE SIGNAL HOUSING AND ANY RELATED ATTACHMENTS TO A SIGNAL FACE LOCATED OVER ANY PORTION OF A HIGHWAY SHALL BE ACCORDING TO CURRENT STATE STANDARDS 877001, 877002, 877006, 877011 AND 877012 WITH A MINIMUM OF 16 FT (5.0 m) AND A MAXIMUM OF 18 FT. (5.5 m) FROM THE HIGHEST POINT OF PAVEMENT.
4. THE BOTTOM OF THE TEMPORARY SPAN WIRE MOUNTED SIGNAL HOUSING AND ANY RELATED ATTACHMENTS TO A SIGNAL FACE LOCATED OVER ANY PORTION OF A HIGHWAY SHALL BE ACCORDING TO CURRENT STATE STANDARD 880001 WITH A MINIMUM OF 17 FT (5.18 m) FROM THE HIGHEST POINT OF PAVEMENT.
5. THE TOP OF THE SIGNAL HOUSING OF A SIGNAL FACE LOCATED OVER ANY PORTION OF A HIGHWAY SHALL NOT BE MORE THAN 25.6 FT (7.8 m) ABOVE THE PAVEMENT.

TRAFFIC SIGNAL EQUIPMENT OFFSET

TRAFFIC SIGNAL EQUIPMENT	COMBINATION CONCRETE CURB AND GUTTER (MINIMUM DISTANCE FROM BACK OF CURB TO CENTERLINE OF FOUNDATION)	SHOULDER/NON-CURBED AREA (MINIMUM DISTANCE FROM EDGE OF PAVEMENT TO CENTERLINE OF FOUNDATION)
TRAFFIC SIGNAL MAST ARM POLE	6 FT (1.8m)	SHOULDER WIDTH + 2 FT (0.6m), MINIMUM 10 FT (3.0m)
TRAFFIC SIGNAL POST	4 FT (1.2m)	SHOULDER WIDTH + 2 FT (0.6m), MINIMUM 10 FT (3.0m)
PEDESTRIAN SIGNAL POST	4 FT (1.2m)	SHOULDER WIDTH + 2 FT (0.6m), MINIMUM 10 FT (3.0m)
PEDESTRIAN PUSHBUTTON POST	4 FT (1.2m)	SHOULDER WIDTH + 2 FT (0.6m), MINIMUM 10 FT (3.0m)
TEMPORARY WOOD POLE	6 FT (1.8m)	SHOULDER WIDTH + 2 FT (0.6m), MINIMUM 10 FT (3.0m)
CONTROLLER CABINET	6 FT (1.8m) MINIMUM DISTANCE SEE NOTE 2	SHOULDER WIDTH + 6 FT (1.8m), MINIMUM 16 FT (4.9m) SEE NOTE 3.
SERVICE INSTALLATION, GROUND MOUNT	6 FT (1.8m) MINIMUM DISTANCE SEE NOTE 2	SHOULDER WIDTH + 6 FT (1.8m), MINIMUM 16 FT (4.9m) SEE NOTE 3.

NOTES:

1. CONTACT THE "AREA TRAFFIC SIGNAL MAINTENANCE AND OPERATIONS ENGINEER" FOR ASSISTANCE IN LOCATING THE TRAFFIC SIGNAL EQUIPMENT WHEN THERE ARE CONFLICTS WITH DITCHES OR THE MINIMUM OFFSET DISTANCES CANNOT BE MET.
2. MINIMUM DISTANCE FROM THE BACK OF CURB TO THE ROADWAY SIDE OF THE FOUNDATION.
3. MINIMUM DISTANCE FROM THE EDGE OF PAVEMENT TO THE ROADWAY SIDE OF THE FOUNDATION.
4. ANY CHANGES TO THE OFFSETS OF THE FOUNDATIONS, FROM THE MINIMUM DISTANCES LISTED IN THE "TRAFFIC SIGNAL EQUIPMENT OFFSET" CHART AND THE TRAFFIC SIGNAL INSTALLATION PLAN, COULD EFFECT THE PLACEMENT OF THE SIGNAL HEADS, PEDESTRIAN SIGNAL HEADS AND THE PEDESTRIAN PUSHBUTTONS. THE SIGNAL HEAD PLACEMENT ON THE MAST ARMS SHALL REMAIN AS PER THE TRAFFIC SIGNAL INSTALLATION PLAN AND THE "TRAFFIC SIGNAL MAST ARM AND SIGNAL POST" DETAIL ABOVE. THE PROPOSED MAST ARM LENGTHS MAY NEED TO BE REVISED TO MEET THE ABOVE REQUIREMENTS. THE PEDESTRIAN SIGNAL HEADS AND PEDESTRIAN PUSHBUTTONS MUST MEET THE REQUIREMENTS UNDER THE DETAILS ON THIS SHEET.

TS SHT NO. 3

MODEL: Default; FILE NAME: S:\WP\Design\KIL\InUse\Design\2019\CMAQ\Interconnect\Project\Contract\27\MS1\SES3\Frc\21\Review\CADD\with-Commissions\Symbol_12-20-19.dwg

USER NAME = bennettidw	DESIGNED -	REVISED -
PLOT SCALE = 50,0000 */ in.	DRAWN -	REVISED -
PLOT DATE = 1/20/2022	CHECKED -	REVISED -
	DATE -	REVISED -

**STATE OF ILLINOIS
DEPARTMENT OF TRANSPORTATION**

**DISTRICT ONE
STANDARD TRAFFIC SIGNAL DESIGN DETAILS**

SCALE: NONE SHEET 3 OF 7 SHEETS STA. TO STA.

F.A. RTE.	SECTION	COUNTY	TOTAL SHEETS	SHEET NO.
2688	2020-250-BY	COOK & WILL	133	49
TS-05		CONTRACT NO. 62N20		
ILLINOIS FED. AID PROJECT				

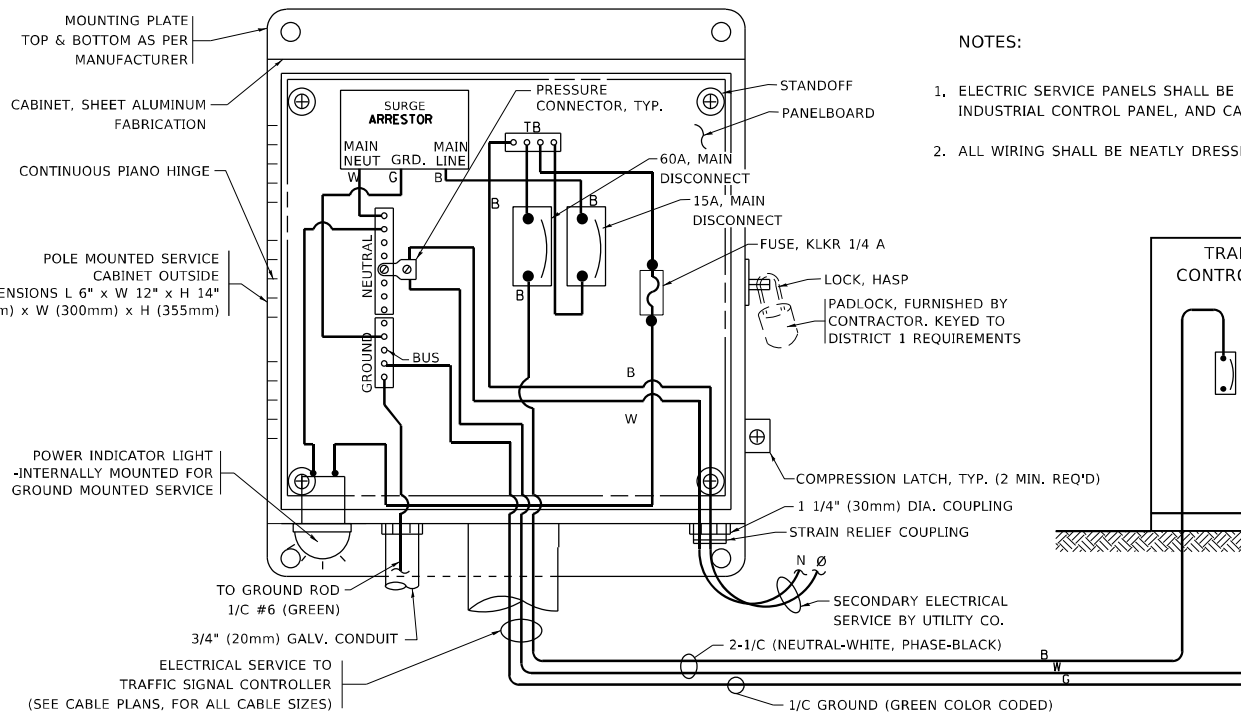

ELECTRICAL SERVICE – PANEL DIAGRAM (TYPICAL FOR POLE AND GROUND MOUNTED SERVICE)
SERVICE INSTALLATION POLE MOUNT (SHOWN)
 (NOT TO SCALE)

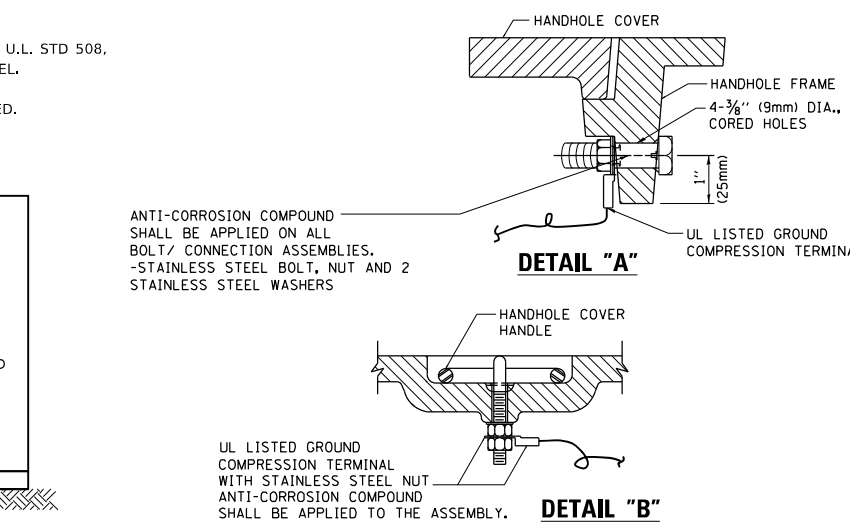

- NOTES:**
- GROUNDING SYSTEM**
- THE GROUNDING SYSTEM SHALL CONSIST OF AN INSULATED CONDUCTOR TYPE XLP, NO. 6 A.W.G., STRANDED COPPER TO BE INSTALLED IN RACEWAYS. THE GROUNDING CABLE SHALL BE INSTALLED IN A CONTINUOUS MANNER AS SHOWN ON THE CABLE PLAN PROVIDED. ALL GROUNDING CONDUCTORS SHALL BE BONDED TO METAL ENCLOSURE (HANDHOLE, POST, MAST ARM, CONTROLLER, ETC.). GROUND ROD SHALL BE 3/4" DIA. x 10'-0" (20mm x 3.0m) LONG, COPPER CLAD. ONE GROUND ROD SHALL BE INSTALLED AT ALL POST FOUNDATIONS, POLE FOUNDATIONS, CONTROLLER CABINET FOUNDATION AND ELECTRICAL SERVICE INSTALLATION AS INDICATED ON THE CABLE PLAN. IF THERE ARE ANY SPECIAL CONDITIONS SUCH AS SUB-SURFACE CONDITIONS OR INSTALLATION PROBLEMS, THE RESIDENT ENGINEER SHALL BE NOTIFIED OR CONTACT THE BUREAU OF TRAFFIC, ILLINOIS DEPARTMENT OF TRANSPORTATION DISTRICT ONE AT (847) 705-4139.
 - THE NEUTRAL CONDUCTOR AND THE GROUND CONDUCTOR SHALL BE CONNECTED IN THE SERVICE INSTALLATION. AT NO OTHER POINT IN THE TRAFFIC SIGNAL SYSTEM SHALL THE NEUTRAL AND GROUND CONDUCTORS BE CONNECTED.
 - ALL EQUIPMENT GROUNDING CONDUCTORS SHALL TERMINATE AT THE GROUND BUS IN THE CONTROLLER CABINET.
 - THE CONTRACTOR SHALL PROVIDE A GROUND CABLE WITH CONNECTORS BETWEEN THE HANDHOLE COVER AND HANDHOLE FRAME.

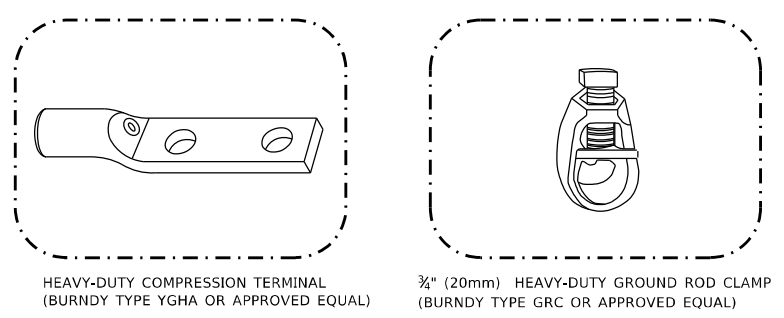

- NOTES:**
- ALL CLAMPS SHALL BE BRONZE OR COPPER, UL APPROVED.
 - GROUND CABLE SHALL BE LOOPED OVER HOOKS IN THE HANDHOLES. 6.5' (2.0m) SLACK SHALL BE PROVIDED IN SINGLE HANDHOLES. 13' (4.0m) OF SLACK SHALL BE PROVIDED IN DOUBLE HANDHOLES. 5' (1.4m) OF SLACK SHALL BE PROVIDED BETWEEN FRAME AND COVER.

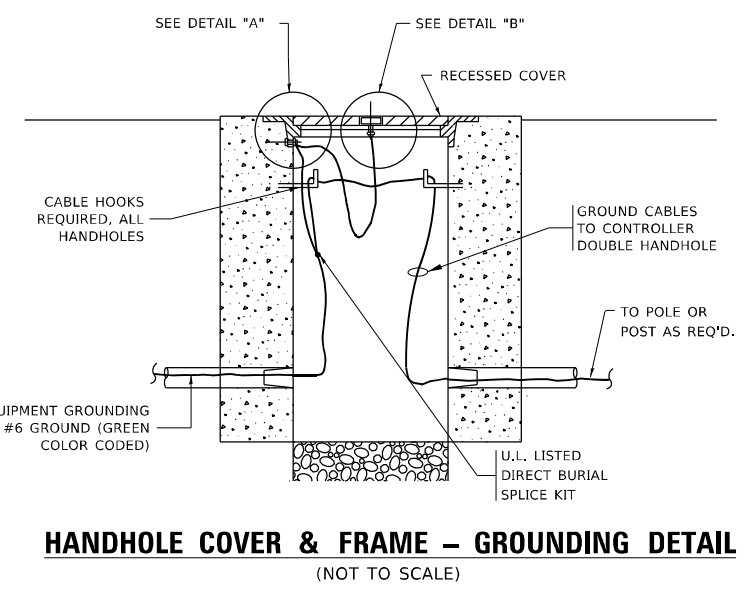

- (2) 1/2" x 1 1/4" STAINLESS STEEL BOLT WITH SPLIT LOCK WASHER AND NYLON INSERT LOCKOUT WELDED TO FRAME AND TO COVER. (TYPICAL). ANTI-CORROSION COMPOUND SHALL BE APPLIED TO EACH ASSEMBLY.

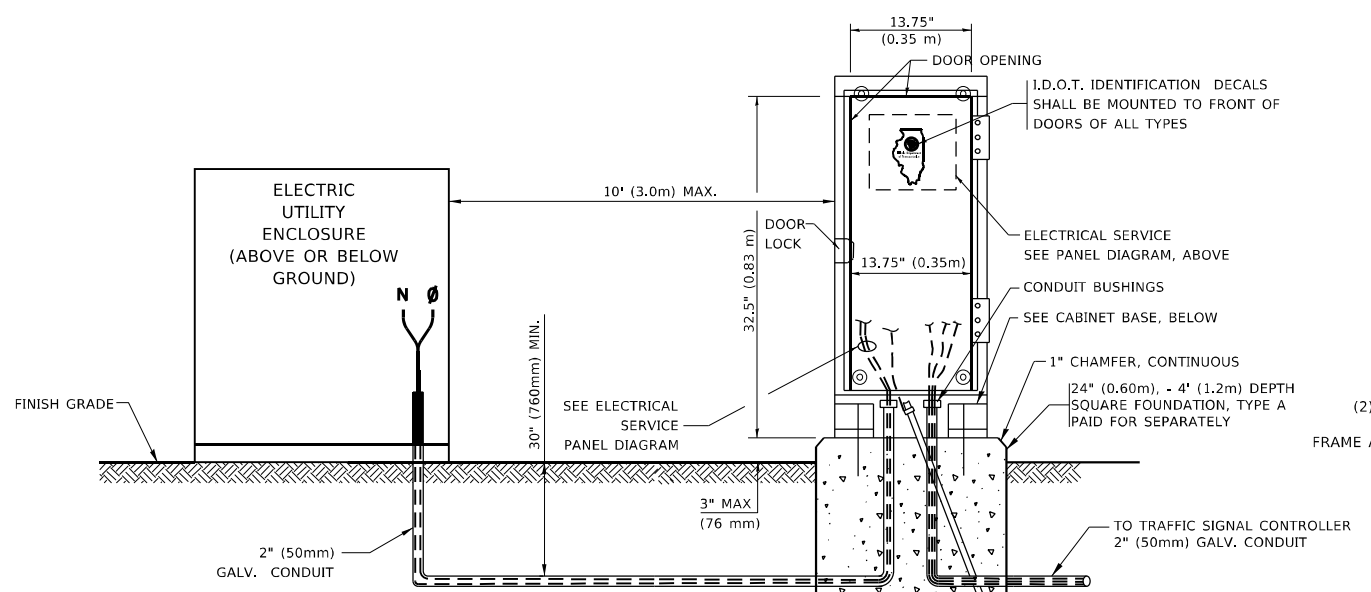
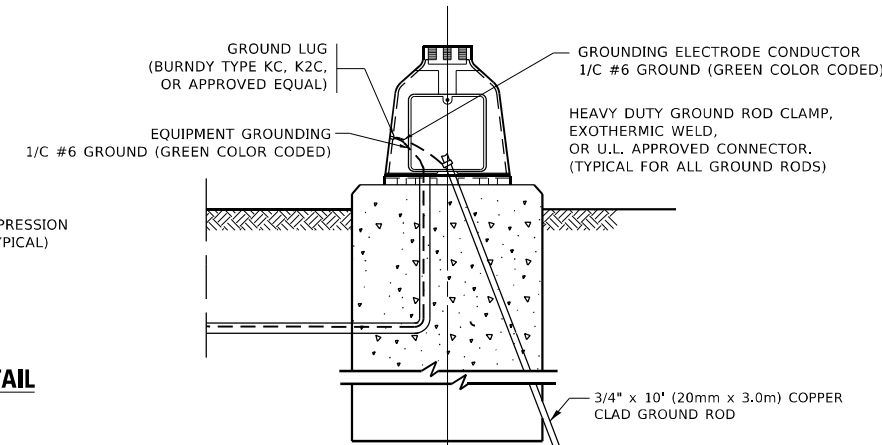
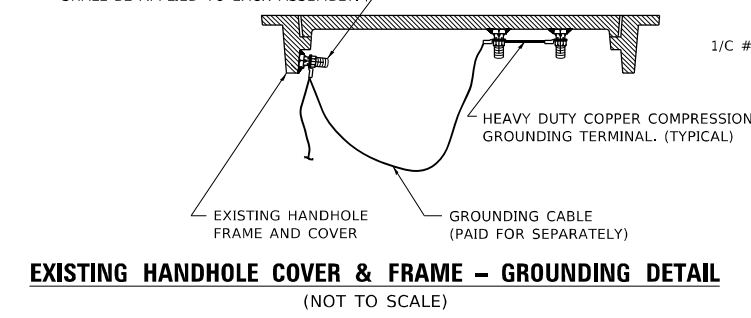

SERVICE INSTALLATION GROUND MOUNT
 (NOT TO SCALE)

CABINET – BASE BOLT PATTERN
 (NOT TO SCALE)

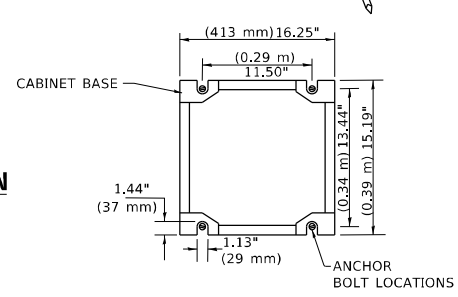

TS SHT NO. 4

MODEL: D:\p\p\Design\K\In\Hous\Design\2019\CMAQ\Interconnect\Projects\Contract\2161\SES3\rc\4\TH-Review-CADD-with-Commissions\Symbol\12-20-19.dgn
 FILE NAME: S:\P\Design\K\In\Hous\Design\2019\CMAQ\Interconnect\Projects\Contract\2161\SES3\rc\4\TH-Review-CADD-with-Commissions\Symbol\12-20-19.dgn

USER NAME = bennettidw	DESIGNED -	REVISED -
DRAWN -	REVISED -	REVISED -
PLOT SCALE = 50,0000 */ in.	CHECKED -	REVISED -
PLOT DATE = 1/20/2022	DATE -	REVISED -

**STATE OF ILLINOIS
 DEPARTMENT OF TRANSPORTATION**

DISTRICT ONE			
STANDARD TRAFFIC SIGNAL DESIGN DETAILS			
SCALE: NONE	SHEET 4	OF 7 SHEETS	STA. TO STA.

F.A. RTE. 2688	SECTION 2020-250-BY	COUNTY COOK & WILL	TOTAL SHEETS 133	SHEET NO. 50
TS-05		CONTRACT NO. 62N20		
ILLINOIS FED. AID PROJECT				

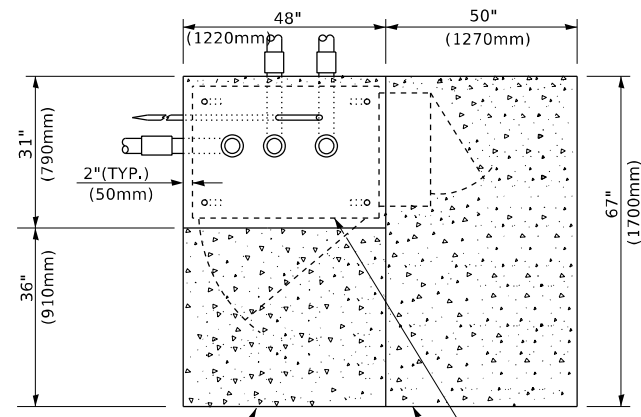

TOP VIEW

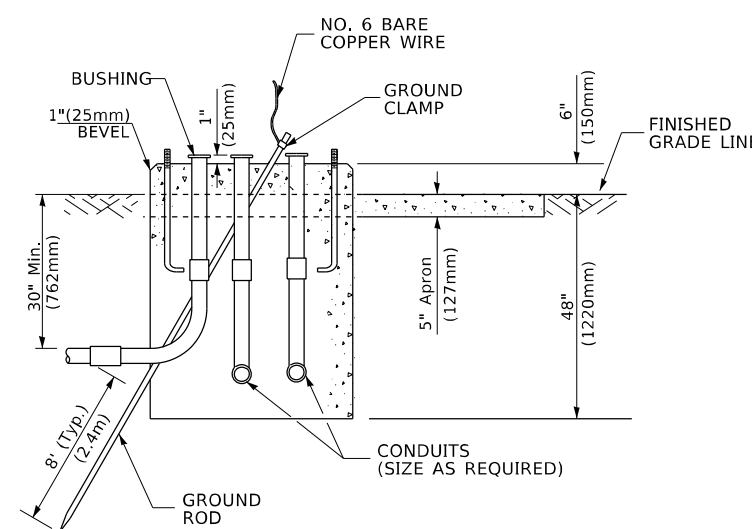

**TYPE D
FOR GROUND MOUNTED
CONTROLLER CABINET
AND UPS BATTERY CABINET**

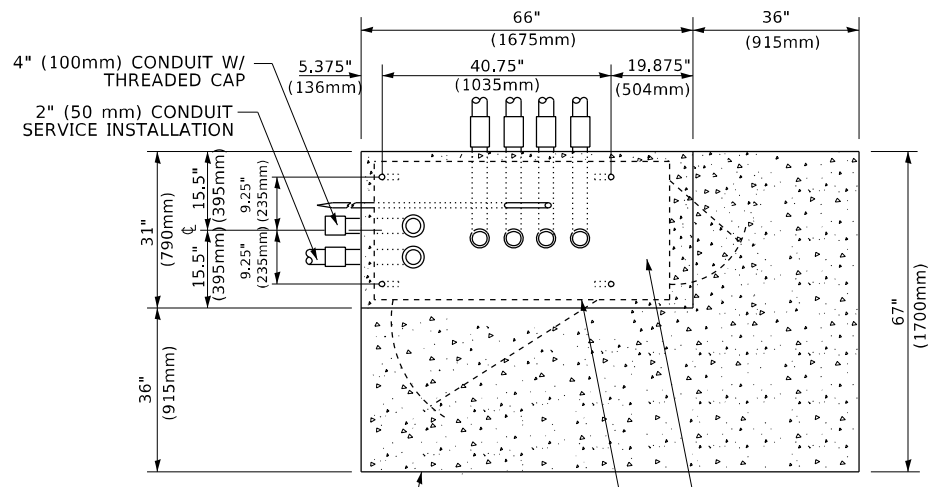

TOP VIEW

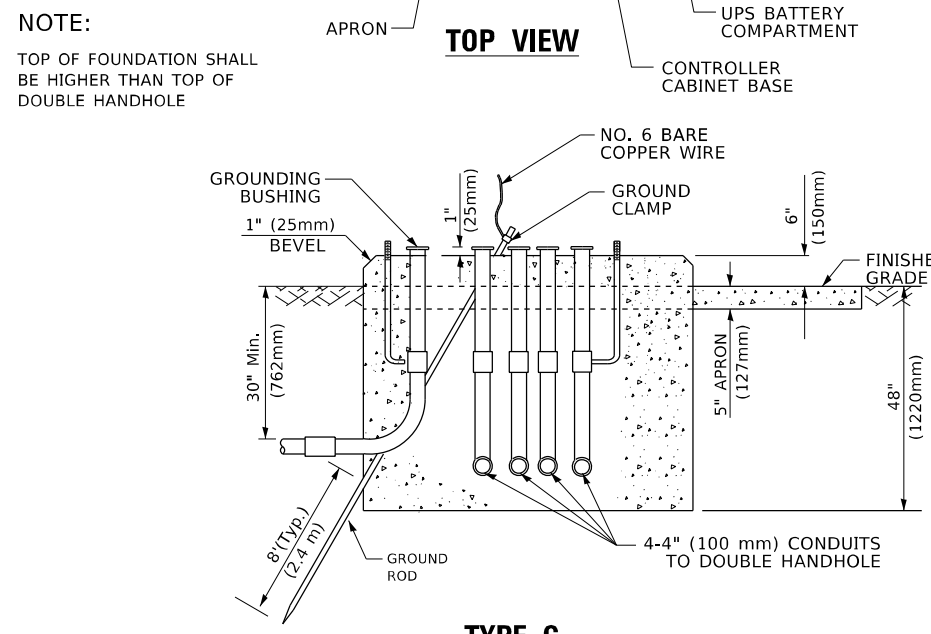

**TYPE C
FOR GROUND MOUNTED
SUPER P (TYPE IV) AND SUPER R (TYPE V)
CONTROLLER CABINETS**

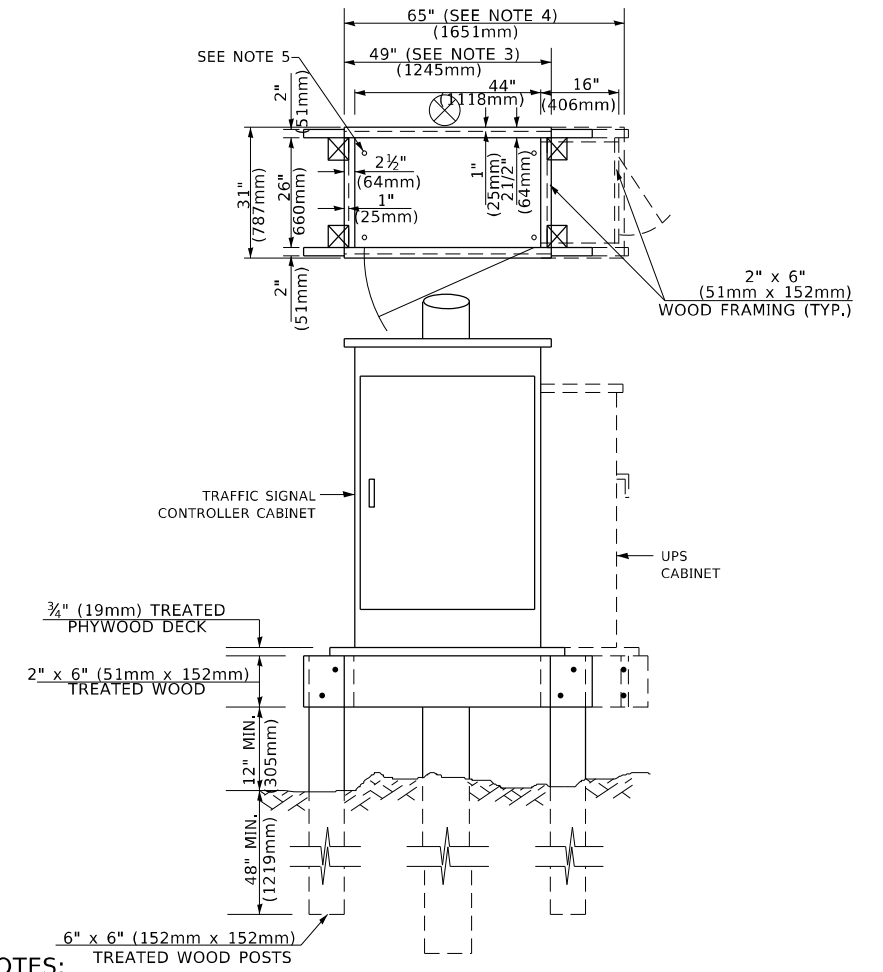

NOTES:

1. BASED ON CONTROLLER CABINET TYPE IV WITH BASE DIMENSIONS OF 26" x 44" (660mm x 1118mm). ADJUST PLATFORM SIZE TO FIT CABINET BASE DIMENSIONS BEING SUPPLIED.
2. BASED ON UNINTERRUPTIBLE POWER SUPPLY CABINET WITH BASE DIMENSIONS OF 16" x 25" (406mm x 635mm). ADJUST PLATFORM SIZE TO FIT CABINET BASE DIMENSIONS BEING SUPPLIED.
3. PLATFORM SIZE FOR CONTROLLER CABINET TYPE IV.
4. PLATFORM SIZE FOR CONTROLLER CABINET TYPE IV AND UNINTERRUPTIBLE POWER SUPPLY CABINET.
5. DRILLED HOLES THROUGH THE PLATFORM BASE TO MATCH THE CONTROLLER CABINET BOLT TEMPLATE. FASTEN THE CONTROLLER CABINET TO THE PLATFORM WITH CARRIAGE BOLTS, WASHERS AND NUTS.
6. FASTEN ALL SUPPORT WOOD FRAMING TO THE WOOD POSTS WITH 2 LAG SCREWS FOR EACH CONNECTION..

**TEMPORARY SIGNAL CONTROLLER
WOOD SUPPORT PLATFORM**

CABLE SLACK LENGTH	FEET	METER
HANDHOLE	6.5	2.0
DOUBLE HANDHOLE	13.0	4.0
SIGNAL POST	2.0	0.6
MAST ARM	2.0	0.6
CONTROLLER CABINET	1.5	0.5
FIBER OPTIC AT CABINET	13.0	4.0
ELECTRIC SERVICE AT (CABINET OR SERVICE LOCATION)	1.5	0.5
GROUND CABLE (SIGNAL POST, MAST ARM, CABINET)	1.5	0.5
GROUND CABLE (BETWEEN FRAME AND COVER)	5.0	1.6

CABLE SLACK

VERTICAL CABLE LENGTH	FEET	METER
MAST ARM POLE (MAST ARM MOUNTED SIGNAL HEAD) (L = MAST ARM LENGTH - DISTANCE TO SIGNAL HEAD FROM END OF ARM)	20.0+L	6.0+L
BRACKET MOUNTED (MAST ARM POLE OR SIGNAL POLE)	13.0	4.0
PEDESTRIAN PUSH BUTTON	6.0	2.0
SERVICE INSTALLATION POLE MOUNT TO SERVICE DROP	13.5	4.1
SERVICE INSTALLATION POLE MOUNT TO GROUND	13.5	4.1
SERVICE INSTALLATION GROUND MOUNT	6.0	2.0
FOUNDATION (SIGNAL POST, MAST ARM POLE, CONTROLLER CABINET, SERVICE-GROUND MOUNT)	3.0	1.0

VERTICAL CABLE LENGTH

FOUNDATION	DEPTH
TYPE A - Signal Post	4'-0" (1.2m)
TYPE C - CONTROLLER W/ UPS	4'-0" (1.2m)
TYPE D - CONTROLLER	4'-0" (1.2m)
SERVICE INSTALLATION, GROUND MOUNT, TYPE A - SQUARE	4'-0" (1.2m)

DEPTH OF FOUNDATION

MAST ARM LENGTH	① FOUNDATION DEPTH	FOUNDATION DIAMETER	SPIRAL DIAMETER	QUANTITY OF REBARS	SIZE OF REBARS
Less than 30' (9.1 m)	10'-0" (3.0 m)	30" (750mm)	24" (600mm)	8	6(19)
Greater than or equal to 30' (9.1 m) and less than 40' (12.2 m)	13'-6" (4.1 m)	30" (750mm)	24" (600mm)	8	6(19)
Greater than or equal to 40' (12.2 m) and less than 50' (15.2 m)	11'-0" (3.4 m)	36" (900mm)	30" (750mm)	12	7(22)
Greater than or equal to 50' (15.2 m) and up to 55' (16.8 m)	13'-0" (4.0 m)	36" (900mm)	30" (750mm)	12	7(22)
Greater than or equal to 55' (16.8 m) and less than 65' (19.8 m)	15'-0" (4.6 m)	36" (900mm)	30" (750mm)	12	7(22)
Greater than or equal to 65' (19.8 m) and up to 75' (22.9 m)	21'-0" (6.4 m)	42" (1060mm)	36" (900mm)	16	8(25)
	25'-0" (7.6 m)	42" (1060mm)	36" (900mm)	16	8(25)

NOTES:

1. These foundation depths are for sites which have cohesive soils (clayey silt, sandy clay, etc.) along the length of the shaft, with an average unconfined compressive strength (qu) > 1.0 tsf (100 kpa). This strength shall be verified by boring data prior to construction or with testing by the Engineer during foundation drilling. The Bureau of Bridges & Structures should be contacted for a revised design if other conditions are encountered.
2. Combination mast arm assemblies under 55 feet (16.8 m) shall use 36" (900 mm) diameter foundations.
3. Combination mast arm assemblies under 56 feet (16.8 m) through 75 feet (22.9 m) shall use 42" (1060 mm) diameter foundations.
4. For mast arm assemblies with dual arms refer to state standard 878001..

DEPTH OF MAST ARM FOUNDATIONS, TYPE E

TS SHT NO. 5

MODEL: D:\p\Design\KCK\InHouse\Design\2019\2019-CMAA\04\Interconnect\Project\Contract-627\61-SES3\Arc\2\TH-Review-CADD-with-Commissions\Symbol_12-2-10-19.dwg

USER NAME = bennettidw	DESIGNED -	REVISED -
PLOT SCALE = 50,0000 * / in.	DRAWN -	REVISED -
PLOT DATE = 1/20/2022	CHECKED -	REVISED -
	DATE -	REVISED -

**STATE OF ILLINOIS
DEPARTMENT OF TRANSPORTATION**

**DISTRICT ONE
STANDARD TRAFFIC SIGNAL DESIGN DETAILS**

SCALE: NONE SHEET 5 OF 7 SHEETS STA. TO STA.

F.A. RTE.	SECTION	COUNTY	TOTAL SHEETS	SHEET NO.
2688	2020-250-BY	COOK & WILL	133	51
TS-05		CONTRACT NO. 62N20		
		ILLINOIS FED. AID PROJECT		

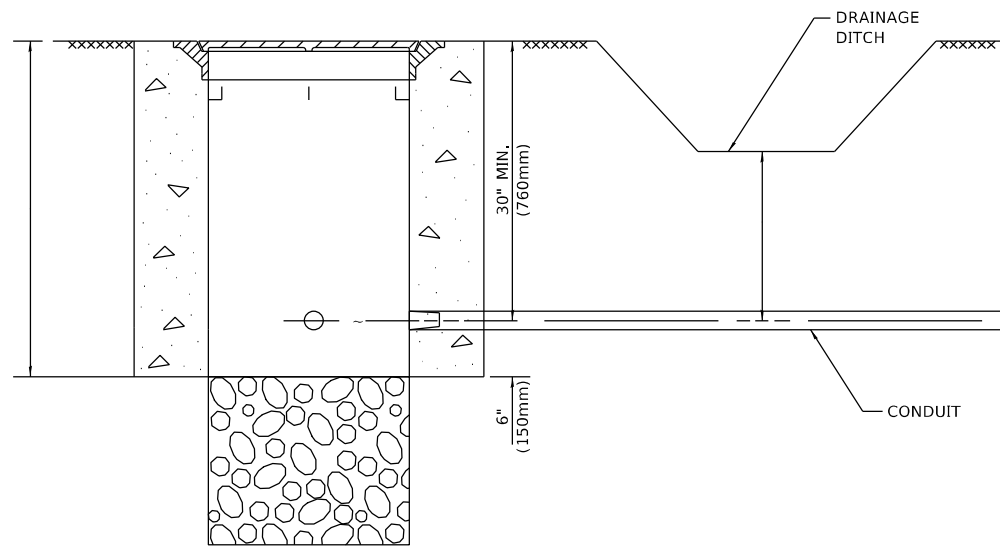

NOTES:

1. CONDUIT DEPTH SHALL BE A MINIMUM OF 30" (760mm) BELOW THE BOTTOM OF THE DRAINAGE DITCH OR ANY SLOPING GROUND
2. THE MINIMUM CONDUIT DEPTH APPLIES TO ALL CONDUIT PLACED UNDER ROADWAY PAVEMENT, MULTI-USE PATHS, SIDEWALKS AND SOIL SURFACES.
3. THE MINIMUM CONDUIT DEPTH APPLIES TO ALL HANDHOLES, HEAVY DUTY HANDHOLES AND DOUBLE HANDHOLES.

HANDHOLE WITH MINIMUM CONDUIT DEPTH
(NOT TO SCALE)

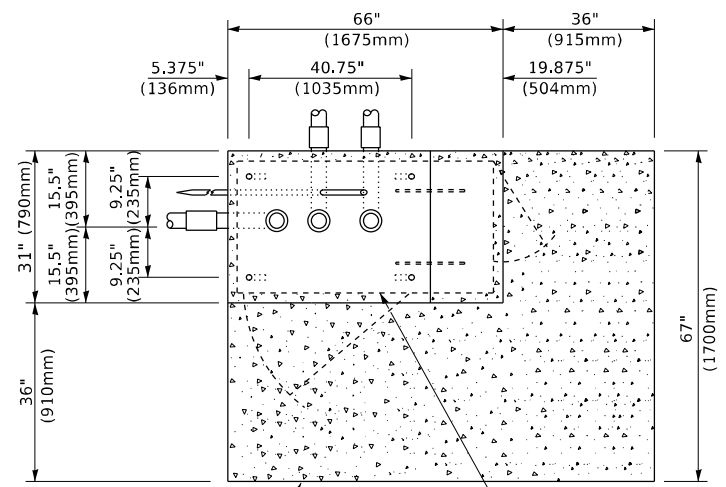

TOP VIEW
(NOT TO SCALE)

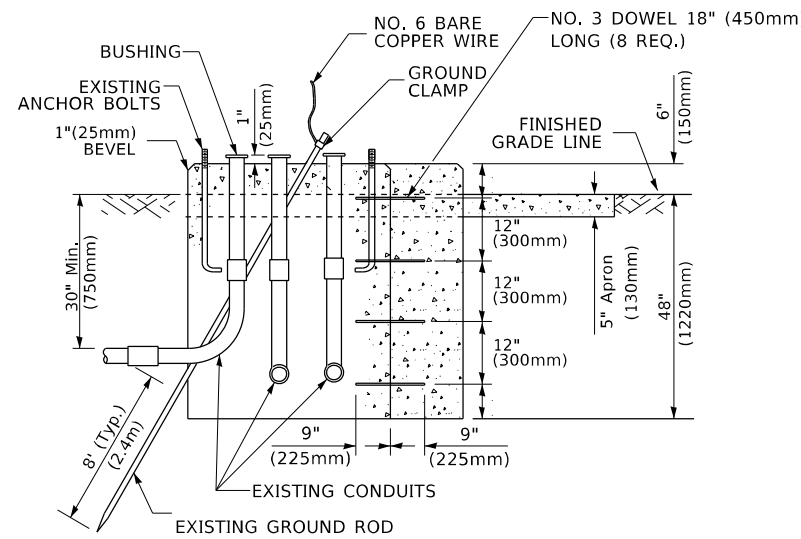

MODIFY EXISTING TYPE "D" FOUNDATION TO TYPE "C" FOUNDATION
(NOT TO SCALE)

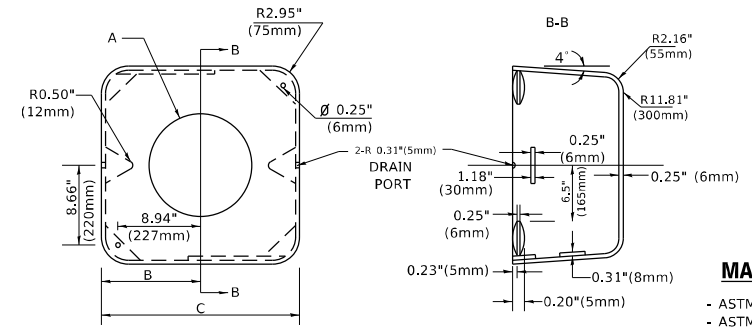

MATERIAL
- ASTM A36 STEEL
- ASTM A-123 HOT DIPPED GALVANIZED

	A	B	C	HEIGHT	WEIGHT
VARIES	9.5"(241mm)	19"(483mm)	7"(178mm)	12" (300mm)	53 lbs (24kg)
VARIES	10.75"(273mm)	21.5"(546mm)	7" (178mm)	12" (300mm)	68 lbs (31 kg)
VARIES	13.0"(330mm)	26"(660mm)	7" (178mm)	12" (300mm)	81 lbs (37 kg)
VARIES	18.5"(470mm)	37"(940mm)	7" (178mm)	12" (300mm)	126 lbs (57 kg)

SHROUD

NOTES:

1. DIMENSION "A" IS EQUAL TO THE DIAMETER OF THE MAST ARM POLE AT THE TOP OF THE SHROUD. THE SHROUD SHALL BE TIGHT TO THE MAST ARM POLE.
2. THE SUPPLIER SHALL VERIFY THE ABOVE DIMENSIONS BASED ON MAST ARM REQUIREMENTS.
3. THE HEIGHT OF THE SHROUD SHALL COVER THE ANCHOR BOLTS, NUTS AND MAST ARM POLE BASE.

NOTE:

SUPPORT EXISTING CABINET AND CONTROL EQUIPMENT ABOVE FOUNDATION TO KEEP TRAFFIC SIGNAL FUNCTIONING WHILE FOUNDATION MODIFICATION WORK IS PROCEEDING.

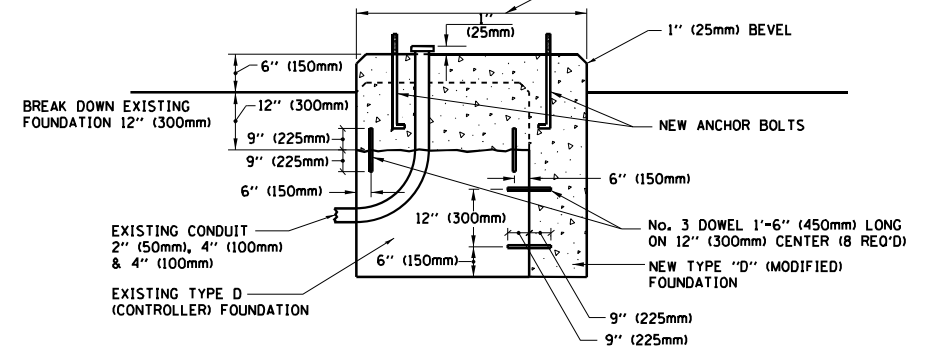

MODIFY EXISTING TYPE "D" FOUNDATION

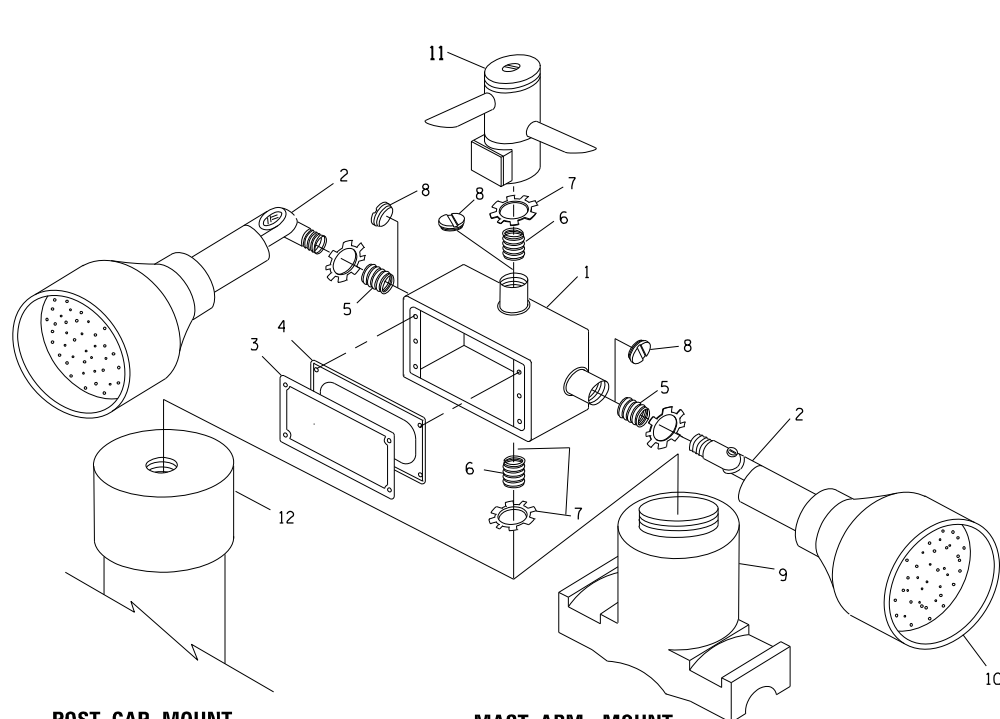

EMERGENCY VEHICLE DETECTOR WITH CONFIRMATION BEACON MOUNTING DETAIL

ITEM NO.	IDENTIFICATION
1	OUTLET BOX- GALV. 21 CU.IN. (0,000344 CU-M)
2	LAMP HOLDER AND COVER
3	OUTLET BOX COVER
4	RUBBER COVER GASKET
5	REDUCING BUSHING
6	3/4"(19 mm) CLOSE NIPPLE
7	3/4"(19 mm) LOCKNUT
8	3/4"(19 mm) HOLE PLUG
9	SADDLE BRACKET - GALV.
10	6 WATT PAR 38 LED FLOOD LAMP
11	DETECTOR UNIT
12	POST CAP [18 FT. (5.4 m) POST MIN.]

NOTES:

1. ALL ELECTRICAL ITEMS, EXCEPT ITEMS #2 AND #11 SHALL BE ALUMINUM OR GALVANIZED
2. ITEM #1- OZ/GEDNEY FSX-1-50 OR EQUIVALENT
ITEM #2- MULBERRY CON-O-SHADE LAMP SHIELD OR EQUIVALENT
ITEM #9- "BAND-IT" SADDLE BRACKET OR EQUIVALENT
3. WHEN POST MOUNTING IS SPECIFIED, ITEM #9 SHALL NOT BE REQUIRED. THE DETECTION UNIT SHALL BE MOUNTED DIRECTLY ON TOP OF THE CAP BY DRILLING AND TAPPING A 3/4 "(19 mm) HOLE WITH PIPE THREADS. THE POST CAP SHALL EITHER BE SCREWED TO THE TOP OF THE POST OR A MINIMUM OF 3 TIGHTENING SCREWS SHALL BE REQUIRED ON EACH CAP.

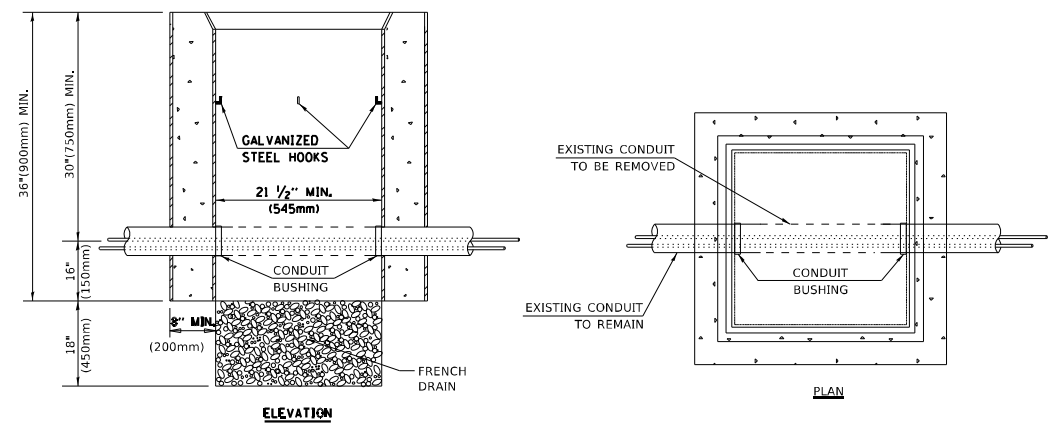

NOTES:

1. HANDHOLE CONSTRUCTED PER STATE STANDARD 814001.
2. REMOVAL OF THE EXISTING CONDUIT FROM THE HANDHOLE AND THE INSTALLATION OF THE CONDUIT BUSHINGS SHALL BE INCLUDED WITH THE COST OF THE HANDHOLE.

HANDHOLE TO INTERCEPT EXISTING CONDUIT

TS SHT NO. 6

MODEL Path: \\p\design\kcl\in\h\o\c\design\2019\CMAQ\interconnect\projects\contract\621861\SES3\rc\c\l\h\Review\CADD\with-Commissions\Symbol_12-20-19.dwg
FILE NAME: \\p\design\kcl\in\h\o\c\design\2019\CMAQ\interconnect\projects\contract\621861\SES3\rc\c\l\h\Review\CADD\with-Commissions\Symbol_12-20-19.dwg

USER NAME = bennettidw	DESIGNED -	REVISED -
PLOT SCALE = 50,0000 * / in.	DRAWN -	REVISED -
PLOT DATE = 1/20/2022	CHECKED -	REVISED -
	DATE -	REVISED -

**STATE OF ILLINOIS
DEPARTMENT OF TRANSPORTATION**

**DISTRICT ONE
STANDARD TRAFFIC SIGNAL DESIGN DETAILS**

SCALE: NONE	SHEET 6 OF 7 SHEETS	STA. TO STA.	F.A. RTE. 2688	SECTION 2020-250-BY TS-05	COUNTY COOK & WILL	TOTAL SHEETS 133	SHEET NO. 52
-------------	---------------------	--------------	----------------	---------------------------	--------------------	------------------	--------------

ILLINOIS FED. AID PROJECT CONTRACT NO. 62N20

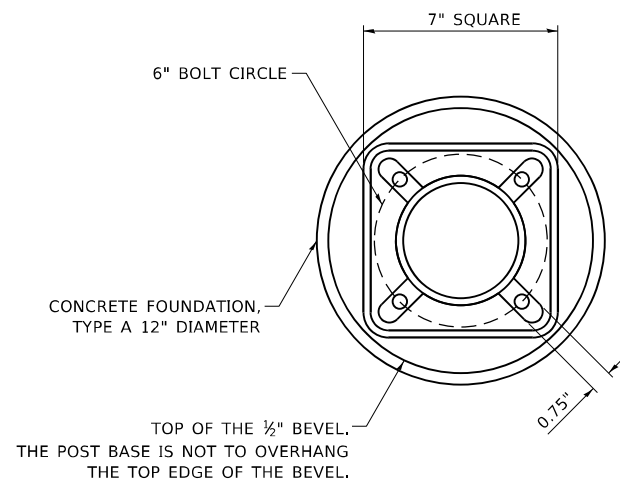

BOLT PATTERN

NOTE:
 1. IF THE PEDESTRIAN SIGNAL POST FOUNDATION IS INSTALLED WITHIN OR BEHIND A BARRIER CURB, THE TOP OF THE FOUNDATION SHALL BE INSTALLED FLUSH WITH THE TOP OF THE BARRIER CURB.

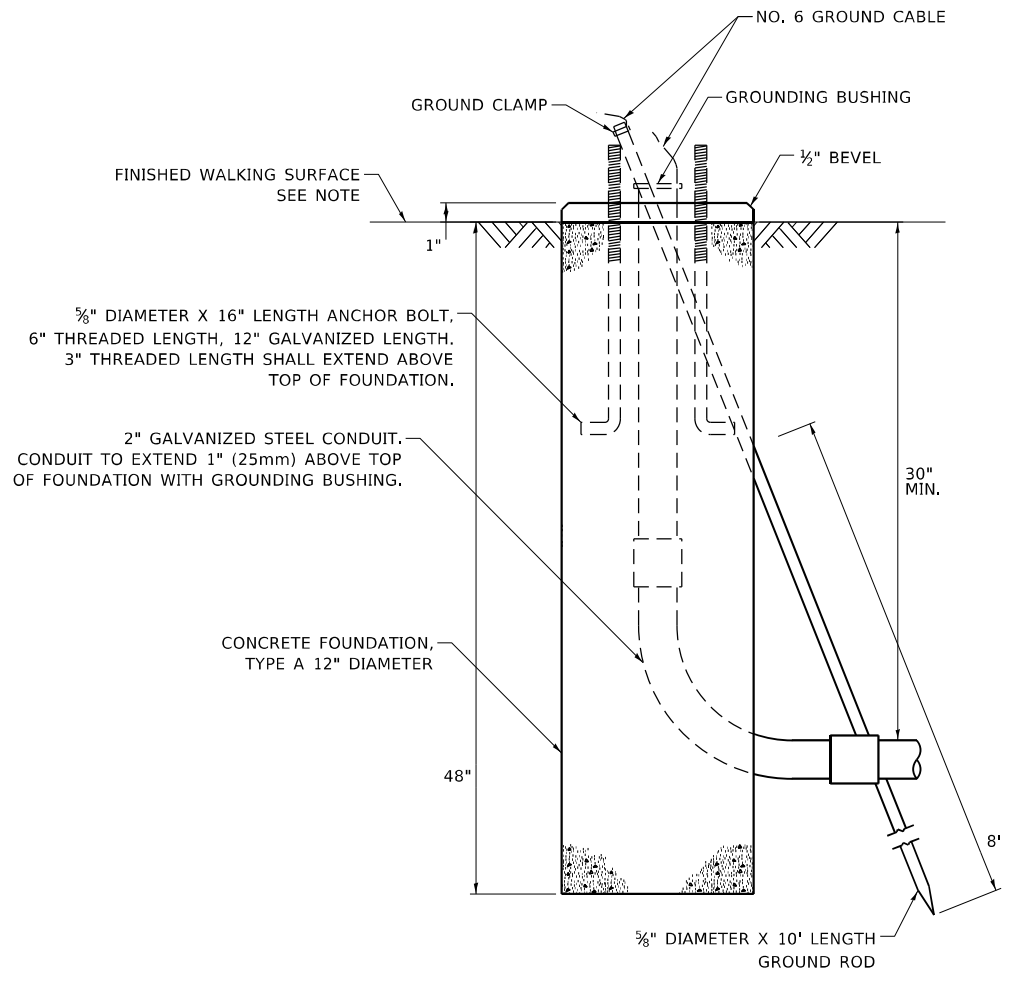

**CONCRETE FOUNDATION,
 TYPE A 12-INCH DIAMETER**

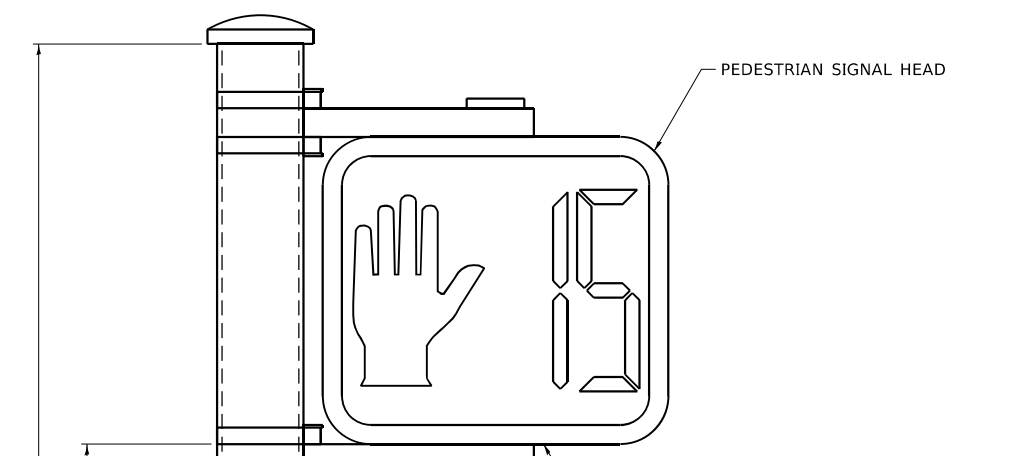

PEDESTRIAN SIGNAL POST, 10 FT.

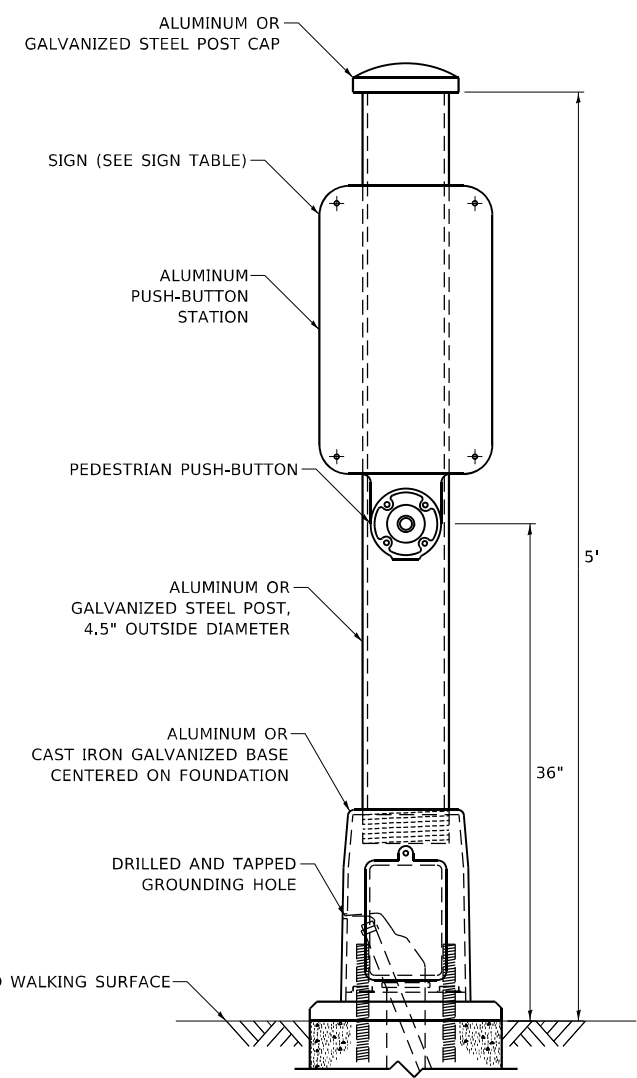

PEDESTRIAN SIGNAL POST, 5 FT.

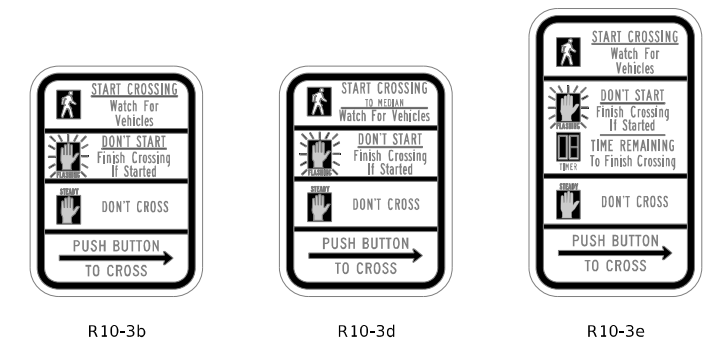

SIGN TABLE

SIGN	DIMENSIONS
R10-3b (RAILROAD ONLY)	9" X 12"
R10-3d (RAILROAD ONLY)	9" X 12"
R10-3e	9" X 15"

NOTES:
 1. THE SIGN PANELS SHALL BE TYPE AP SHEETING.
 2. THE ARROW ON SIGNS FOR PUSH-BUTTONS SERVING TWO DIRECTIONS ON THE SAME PHASE SHALL BE BI-DIRECTIONAL.
 3. THE SIGN FOR DUAL-CALL PUSH-BUTTONS SHALL HAVE NO ARROW.

TS SHT NO. 7

MODEL: D:\p\p\Design\KCI\In\Hous\Design\2019\CMAQ\Interconnect\Projects\Contract\22\MS1\SES3\rc\2\1\Review\CADD\with-Commissions\Symbol_12-20-19.dwg
 FILE NAME: S:\P\Design\KCI\In\Hous\Design\2019\CMAQ\Interconnect\Projects\Contract\22\MS1\SES3\rc\2\1\Review\CADD\with-Commissions\Symbol_12-20-19.dwg

USER NAME = bennettidw	DESIGNED - IP	REVISED -
DRAWN - IP	REVISIONS -	
PLOT SCALE = 50,0000 * / in.	CHECKED - LP	REVISED -
PLOT DATE = 1/20/2022	DATE - 10/15/2018	REVISED -

**STATE OF ILLINOIS
 DEPARTMENT OF TRANSPORTATION**

**DISTRICT ONE
 STANDARD TRAFFIC SIGNAL DESIGN DETAILS**

SCALE: NONE SHEET 7 OF 7 SHEETS STA. TO STA.

F.A. RTE.	SECTION	COUNTY	TOTAL SHEETS	SHEET NO.
2688	2020-250-BY	COOK & WILL	133	53
TS-05		CONTRACT NO. 62N20		
ILLINOIS FED. AID PROJECT				

SIGN PANEL – TYPE 1 OR TYPE 2

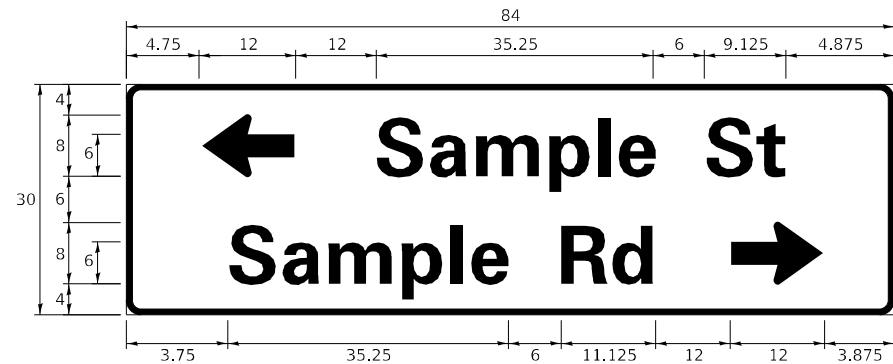
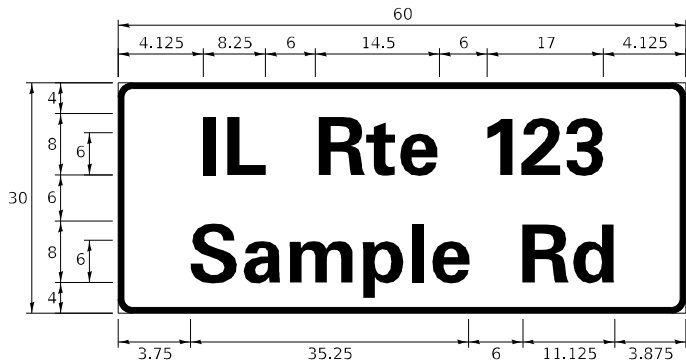

DESIGN SERIES	AREA (SQ FT)	SIGN PANEL TYPE	SHEETING TYPE	QTY. REQUIRED
D OR C	-	1 OR 2	ZZ	-

COMMON STREET NAME ABBREVIATIONS AND WIDTHS

NAME	ABBREVIATION	WIDTH (INCH)	
		SERIES "C"	SERIES "D"
AVENUE	Ave	15.000	18.250
BOULEVARD	Blvd	17.125	20.000
CIRCLE	Cir	11.125	13.000
COURT	Ct	8.250	9.625
DRIVE	Dr	8.625	10.125
HIGHWAY	Hwy	18.375	22.000
ILLINOIS	IL	7.000	8.250
LANE	Ln	9.125	10.750
PARKWAY	Pkwy	23.375	27.375
PLACE	Pl	7.125	7.750
ROAD	Rd	9.625	11.125
ROUTE	Rte	12.625	14.500
STREET	St	8.000	9.125
TERRACE	Ter	12.625	14.625
TRAIL	Tr	7.750	9.125
UNITED STATES	US	10.375	12.250

GENERAL NOTES

- WHERE MAST ARM MOUNTED STREET NAME SIGNS ARE SPECIFIED, THE MAST ARM ASSEMBLY AND POLES SHALL BE DESIGNED TO SUPPORT THE LOADINGS CALLED FOR ON STANDARDS 877001, 877002, 877006, 877011 AND 877012, AS APPLICABLE, PLUS TWO (2) SIGN PANELS 2'-6" x 8'-0" MOUNTED AS SHOWN. THE DESIGN SHALL BE IN ACCORDANCE WITH THE REQUIREMENTS OF THE CURRENT "STANDARD SPECIFICATIONS FOR STRUCTURAL SUPPORTS FOR HIGHWAY SIGNS, LUMINAIRES, AND TRAFFIC SIGNALS" AS PUBLISHED BY THE AMERICAN ASSOCIATION OF STATE HIGHWAY AND TRANSPORTATION OFFICIALS FOR 80 M.P.H. WIND VELOCITY.
- ALL SIGNS SHALL CONSIST OF A WHITE LEGEND AND BORDER (TYPE ZZ SHEETING) ON A GREEN BACKGROUND (TYPE ZZ SHEETING)
- THE SIGN LENGTH SHALL BE IN 6-INCH INCREMENTS, BUT THE OVERALL LENGTH SHALL NOT EXCEED 8'-0". ALL BORDERS IF POSSIBLE, BUT MAY BE REDUCED TO 5" WHEN SPACING IS CRITICAL. A MINIMUM OF 2-1/2" SHALL BE INCLUDED BETWEEN THE WORD AND THE RIGHT AND LEFT EDGES OF THE SIGN.
- A PREFERRED METHOD FOR THE SIGN DESIGN IS TO USE SERIES "D" LETTER ON A ONE-LINE SIGN 18" IN HEIGHT AND A MAXIMUM OF 8'-0" IN WIDTH. IF SERIES "D" DOES NOT FIT ON A 8'-0" SIGN, THEN SERIES "C" SHOULD BE TRIED. IF SERIES "C" DOES NOT FIT ON A 8'-0" SIGN, A 30" HIGH TWO-LINE SIGN CAN BE USED. THE CROSSROAD DESIGNATION AS TO STREET, AVENUE, ETC. SHOULD BE SPELLED OUT ON THE SECOND LINE, IF THE ABBREVIATION CANNOT FIT ON THE FIRST LINE.
- LED ILLUMINATED STREET NAME SIGNS CAN BE USED IN PLACE OF REGULAR SIGN PANELS BUT ANY SPECIAL WORDING AND SYMBOLOGY MUST BE APPROVED BY THE DEPARTMENT. GENERAL DESIGN REQUIREMENT AS LISTED ABOVE (COLOR, FONT, SIZE, ETC.) MUST BE FOLLOWED.
- SIGNFIX ALUMINUM CHANNEL FRAMING SYSTEM SHALL BE USED FOR ALL SIGNS ATTACHED TO SIGNAL POLES AND POSTS.

LOCAL SUPPLIERS:

- J.O. HERBERT COMPANY, INC
MIDLOTHIAN, VA
- WESTERN REMAC, INC.
WOODRIDGE, IL

PARTS LISTING:

- SIGN CHANNEL PART #HPN053 (MED. CHANNEL)
- SIGN SCREWS 1/4" x 14 x 1" H.W.H. #3
- BRACKETS SELF TAPPING WITH NEOPRENE WASHER PART #HPN034 (UNIVERSAL)
- CHANNEL CLAMPS WITH STAINLESS STEEL STRAPPING

OTHER BRANDS OF MOUNTING HARDWARE ARE ACCEPTABLE, BASED UPON THE DEPARTMENT'S APPROVAL AND COMPATIBILITY WITH THE CHANNEL/BACKET OF THE ABOVE PRODUCT.

MOUNTING LOCATION

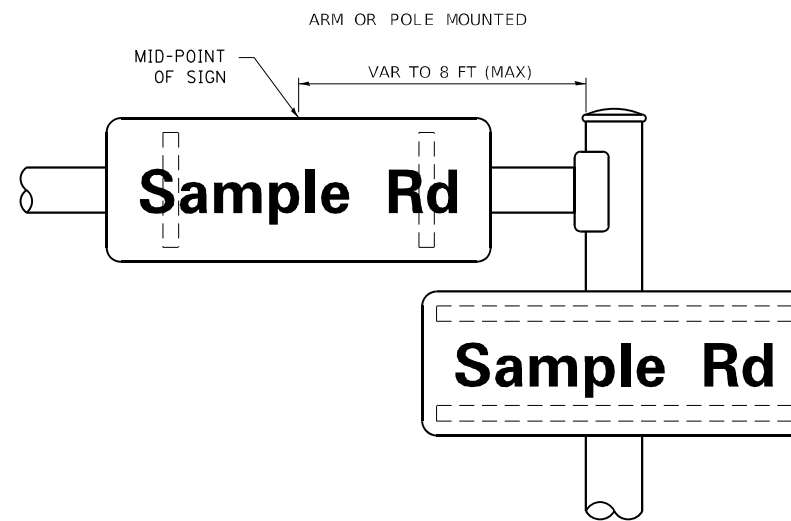

SUPPORTING CHANNELS

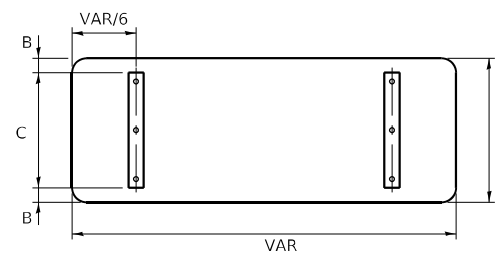

A	B	C
18"	2"	14"
30"	2"	24"

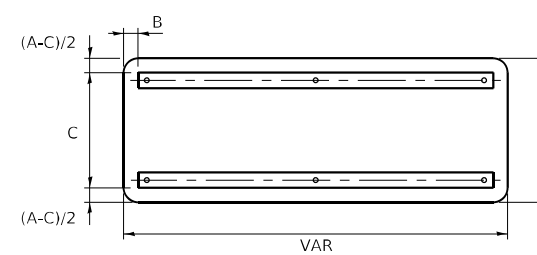

A	B	C
18"	2"	12"
30"	2"	22"

STANDARD ALPHABETS SPACING CHART

(8") UPPER CASE AND (6") LOWER CASE

CHARACTER	FHWA SERIES "C"			CHARACTER	FHWA SERIES "D"		
	LEFT SPACING (INCH)	WIDTH (INCH)	RIGHT SPACING (INCH)		LEFT SPACING (INCH)	WIDTH (INCH)	RIGHT SPACING (INCH)
A	0.240	5.122	0.240	A	0.240	6.804	0.240
B	0.880	4.482	0.480	B	0.960	5.446	0.400
C	0.720	4.482	0.720	C	0.800	5.446	0.800
D	0.880	4.482	0.720	D	0.960	5.446	0.800
E	0.880	4.082	0.480	E	0.960	4.962	0.400
F	0.880	4.082	0.240	F	0.960	4.962	0.240
G	0.720	4.482	0.720	G	0.800	5.446	0.800
H	0.880	4.482	0.880	H	0.960	5.446	0.960
I	0.880	1.120	0.880	I	0.960	1.280	0.960
J	0.240	4.082	0.880	J	0.240	5.122	0.960
K	0.880	4.482	0.480	K	0.960	5.604	0.400
L	0.880	4.082	0.240	L	0.960	4.962	0.240
M	0.880	5.284	0.880	M	0.960	6.244	0.960
N	0.880	4.482	0.880	N	0.960	5.446	0.960
O	0.720	4.722	0.720	O	0.800	5.684	0.800
P	0.880	4.482	0.720	P	0.960	5.446	0.240
Q	0.720	4.722	0.720	Q	0.800	5.684	0.800
R	0.880	4.482	0.480	R	0.960	5.446	0.400
S	0.480	4.482	0.480	S	0.400	5.446	0.400
T	0.240	4.082	0.240	T	0.240	4.962	0.240
U	0.880	4.482	0.880	U	0.960	5.446	0.960
V	0.240	4.962	0.240	V	0.240	6.084	0.240
W	0.240	6.084	0.240	W	0.240	7.124	0.240
X	0.240	4.722	0.240	X	0.400	5.446	0.400
Y	0.240	5.122	0.240	Y	0.240	6.884	0.240
Z	0.480	4.482	0.480	Z	0.400	5.446	0.400
a	0.320	3.842	0.640	a	0.400	4.562	0.720
b	0.720	4.082	0.480	b	0.800	4.802	0.480
c	0.480	4.002	0.240	c	0.480	4.722	0.240
d	0.480	4.082	0.720	d	0.480	4.802	0.800
e	0.480	4.082	0.320	e	0.480	4.722	0.320
f	0.320	2.480	0.160	f	0.320	2.882	0.160
g	0.480	4.082	0.720	g	0.480	4.802	0.800
h	0.720	4.082	0.640	h	0.800	4.722	0.720
i	0.720	1.120	0.720	i	0.800	1.280	0.800
j	0.000	2.320	0.720	j	0.000	2.642	0.800
k	0.720	4.322	0.160	k	0.800	5.122	0.160
l	0.720	1.120	0.720	l	0.800	1.280	0.800
m	0.720	6.724	0.640	m	0.800	7.926	0.720
n	0.720	4.082	0.640	n	0.800	4.722	0.720
o	0.480	4.082	0.480	o	0.480	4.882	0.480
p	0.720	4.082	0.480	p	0.800	4.802	0.480
q	0.480	4.082	0.720	q	0.480	4.802	0.800
r	0.720	2.642	0.160	r	0.800	3.042	0.160
s	0.320	3.362	0.240	s	0.320	3.762	0.240
t	0.080	2.882	0.080	t	0.080	3.202	0.080
u	0.640	4.082	0.720	u	0.720	4.722	0.800
v	0.160	4.722	0.160	v	0.160	5.684	0.160
w	0.160	7.524	0.160	w	0.160	9.046	0.160
x	0.000	5.202	0.000	x	0.000	6.244	0.000
y	0.160	4.962	0.160	y	0.160	6.004	0.160
z	0.240	3.362	0.240	z	0.240	4.002	0.240
1	0.720	1.680	0.880	1	0.800	2.000	0.960
2	0.480	4.482	0.480	2	0.800	5.446	0.800
3	0.480	4.482	0.480	3	1.440	5.446	0.800
4	0.240	4.962	0.720	4	0.160	6.004	0.960
5	0.480	4.482	0.480	5	0.800	5.446	0.800
6	0.720	4.482	0.720	6	0.800	5.446	0.800
7	0.240	4.482	0.720	7	0.560	5.446	0.560
8	0.480	4.482	0.480	8	0.800	5.446	0.800
9	0.480	4.482	0.480	9	0.800	5.446	0.800
0	0.720	4.722	0.720	0	0.800	5.684	0.800
-	0.240	2.802	0.240	-	0.240	2.802	0.240

TS SHT NO. 8

MODEL: D:\p\Design\K\Illinois\Design\2012\CMAQ\Interconnect\Project\Contract\2\MSL\SES3\rc\Illinois\Review\CADD\with-Commissions\Symbol_12-20-15.dwg
FILE NAME: S:\P\Design\K\Illinois\Design\2012\CMAQ\Interconnect\Project\Contract\2\MSL\SES3\rc\Illinois\Review\CADD\with-Commissions\Symbol_12-20-15.dwg

USER NAME = bennettidw	DESIGNED - LP/IP	REVISED - LP 07/01/2015
PLOT SCALE = 50,0000 / in.	DRAWN - LP	REVISED -
PLOT DATE = 1/20/2022	CHECKED - IP	REVISED -
	DATE - 10/01/2014	REVISED -

STATE OF ILLINOIS
DEPARTMENT OF TRANSPORTATION

DISTRICT ONE
MAST ARM MOUNTED STREET NAME SIGNS

SCALE: SHEET OF SHEETS STA. TO STA.

F.A. RTE. 2688	SECTION 2020-250-BY TS-02	COUNTY COOK & WILL	TOTAL SHEETS 133	SHEET NO. 54
ILLINOIS		FED. AID PROJECT CONTRACT NO. 62N20		

TEMPORARY CONTROLLER SEQUENCE

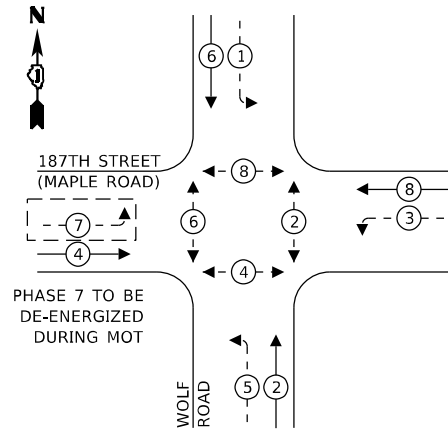

LEGEND:

- ← * → PROTECTED PHASE
- ← - * - → PROTECTED/PERMITTED PHASE
- ← * → PEDESTRIAN PHASE
- ← * OL → OVERLAP

TEMPORARY EMERGENCY VEHICLE PREEMPTION SEQUENCE

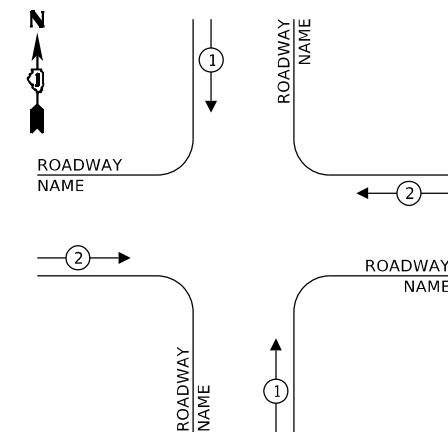

TRAFFIC SIGNAL ELECTRICAL SERVICE REQUIREMENTS

TYPE	NO. OF LAMPS	LED WATTAGE	% OPERATION	TOTAL WATTAGE
SIGNAL (RED)	12	11	50	66.0
(YELLOW)	12	20	5	12.0
(GREEN)	12	12	45	64.8
PERMISSIVE ARROW	12	10	10	12.0
PED. SIGNAL	8	20	100	160.0
CONTROLLER	1	100	100	100.0
UPS	1	25	100	25.0
VIDEO SYSTEM	-	150	100	-
BLANK-OUT SIGN	-	25	5	-
FLASHER	-	-	50	-
STREET NAME SIGN	-	120	50	-
LUMINAIRE	-	-	-	-
TOTAL =				439.8

ENERGY COSTS TO:

VILLAGE OF MOKENA
11004 CARPENTER STREET
MOKENA, IL 60488

ENERGY SUPPLY: CONTACT: TIM COSLET
PHONE: (815) 724-5010
COMPANY: COMMONWEALTH EDISON
ACCOUNT NUMBER: ---

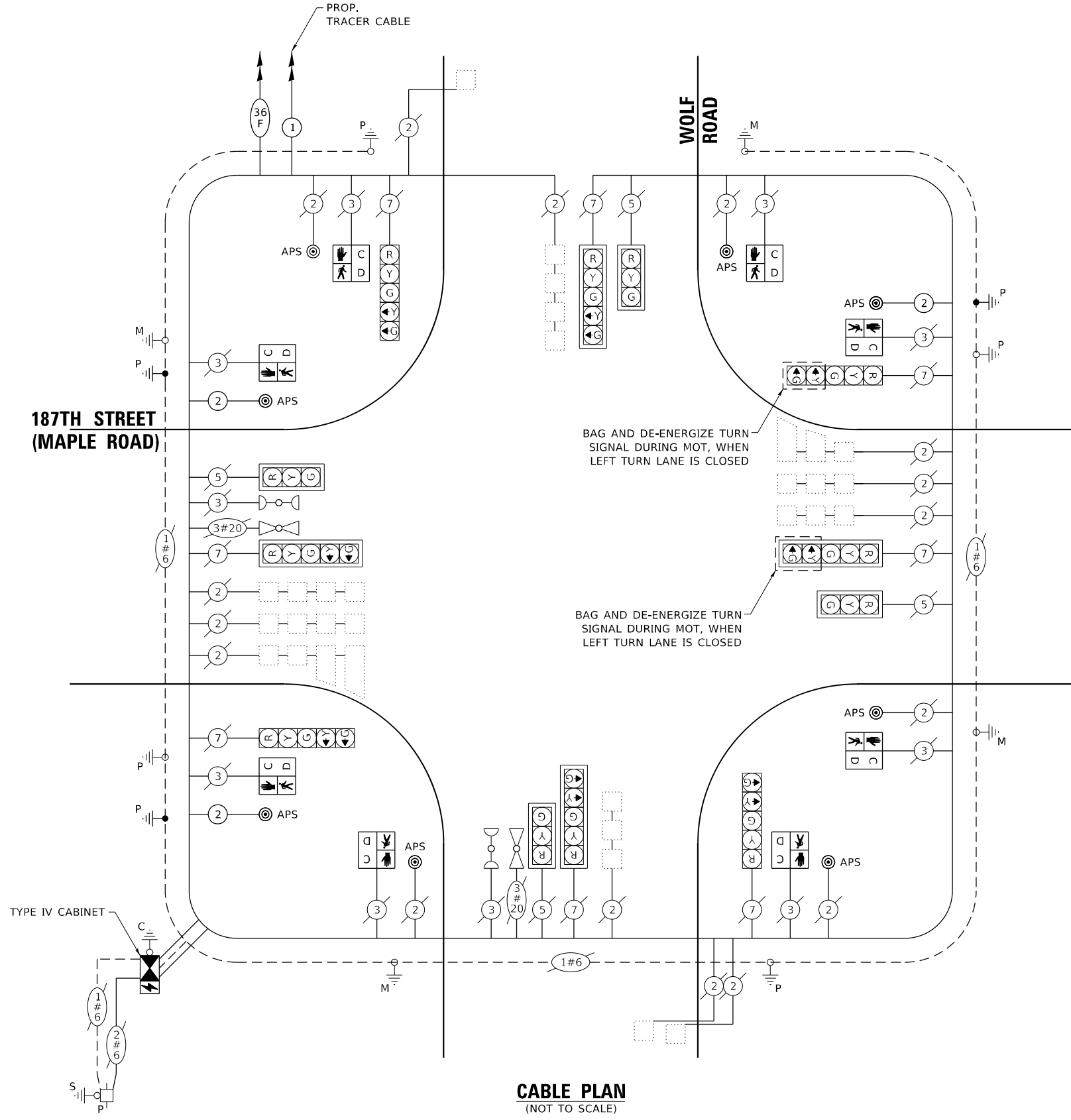

CABLE PLAN
(NOT TO SCALE)

TS SHT NO. 09

MODEL: D:\p\h\... FILE NAME: S:\p\Design\K\In\Hoc\Des\figm\2019\CMAQ\Interconnect\Proj\csc\Contract\2\MS1\SES3\p\c\TL\Review\CADD\with-Commissions\112223-Temp\Cable_Plan.dgn

USER NAME = bennettidw	DESIGNED - DB	REVISED -
PLOT SCALE = 40,0000 * / in.	DRAWN - DB	REVISED -
PLOT DATE = 1/27/2022	CHECKED - KK	REVISED -
	DATE -	REVISED -

STATE OF ILLINOIS
DEPARTMENT OF TRANSPORTATION

TEMPORARY CABLE PLAN, PHASE DESIGNATION DIAGRAM, AND EMERGENCY VEHICLE PREEMPTION SEQUENCE
WOLF ROAD AT 187TH STREET (MAPLE ROAD)

F.A. RTE.	SECTION	COUNTY	TOTAL SHEETS	SHEET NO.
2688	2020-250-BY	COOK & WILL	133	55
			CONTRACT NO. 62N20	
ILLINOIS FED. AID PROJECT				

TSW 0139
ECON:

SCALE: SHEET OF SHEETS STA. TO STA.

SCHEDULE OF QUANTITIES

ITEM DESCRIPTION	UNITS	TOTAL QTY
UNDERGROUND CONDUIT, GALVANIZED STEEL, 2" DIA.	FOOT	60
MAINTENANCE OF EXISTING TRAFFIC SIGNAL INSTALLATION	EACH	1
ELECTRIC CABLE IN CONDUIT, SIGNAL NO. 14 2C	FOOT	480
ELECTRIC CABLE IN CONDUIT, EQUIPMENT GROUNDING CONDUCTOR, NO. 6 1C	FOOT	110
DRILL EXISTING HANDHOLE	EACH	3
PEDESTRIAN SIGNAL HEAD, LED, 1-FACE, BRACKET MOUNTED WITH COUNTDOWN TIMER	EACH	8
INDUCTIVE LOOP DETECTOR	FOOT	11
DETECTOR LOOP REPLACEMENT	EACH	50
RELOCATE EXISTING EMERGENCY VEHICLE PRIORITY SYSTEM, PHASING UNIT	EACH	1
REMOVE EXISTING TRAFFIC SIGNAL EQUIPMENT	EACH	1
PEDESTRIAN SIGNAL POST, 5 FT.	EACH	3
FULL-ACTUATED CONTROLLER AND TYPE IV CABINET, SPECIAL	EACH	1
ACCESSIBLE PEDESTRIAN SIGNALS	EACH	8
CONCRETE FOUNDATION, TYPE A 12-INCH DIAMETER	EACH	12
RE-OPTIMIZE TRAFFIC SIGNAL SYSTEM LEVEL 2	EACH	1
TEMPORARY TRAFFIC SIGNAL TIMING	EACH	1

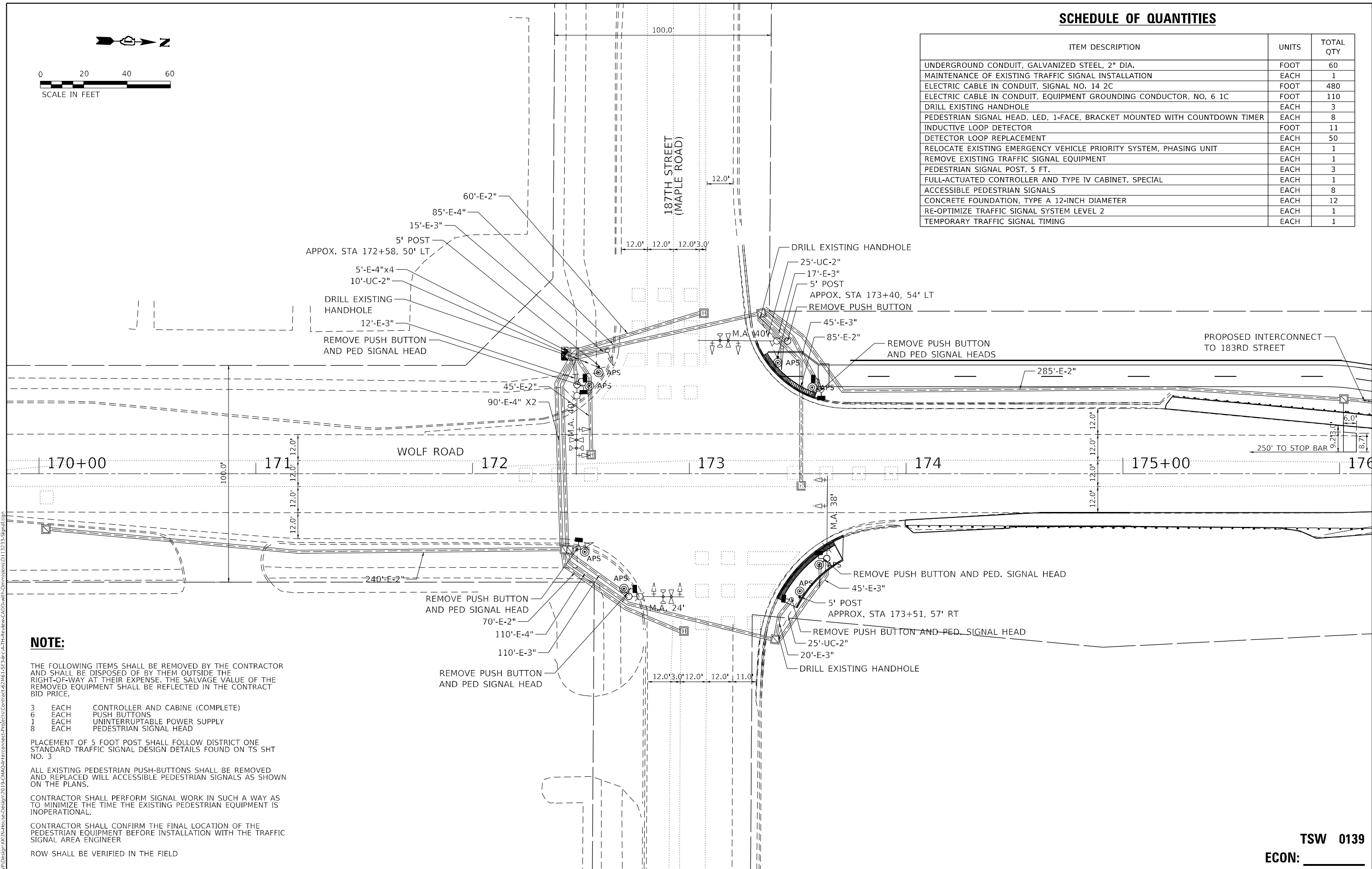
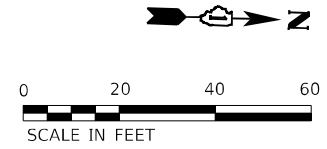

NOTE:

THE FOLLOWING ITEMS SHALL BE REMOVED BY THE CONTRACTOR AND SHALL BE DISPOSED OF BY THEM OUTSIDE THE RIGHT-OF-WAY AT THEIR EXPENSE. THE SALVAGE VALUE OF THE REMOVED EQUIPMENT SHALL BE REFLECTED IN THE CONTRACT BID PRICE.

3	EACH	CONTROLLER AND CABINE (COMPLETE)
6	EACH	PUSH BUTTONS
1	EACH	UNINTERRUPTABLE POWER SUPPLY
8	EACH	PEDESTRIAN SIGNAL HEAD

PLACEMENT OF 5 FOOT POST SHALL FOLLOW DISTRICT ONE STANDARD TRAFFIC SIGNAL DESIGN DETAILS FOUND ON TS SHT NO. 3

ALL EXISTING PEDESTRIAN PUSH-BUTTONS SHALL BE REMOVED AND REPLACED WILL ACCESSIBLE PEDESTRIAN SIGNALS AS SHOWN ON THE PLANS.

CONTRACTOR SHALL PERFORM SIGNAL WORK IN SUCH A WAY AS TO MINIMIZE THE TIME THE EXISTING PEDESTRIAN EQUIPMENT IS INOPERATIONAL.

CONTRACTOR SHALL CONFIRM THE FINAL LOCATION OF THE PEDESTRIAN EQUIPMENT BEFORE INSTALLATION WITH THE TRAFFIC SIGNAL AREA ENGINEER

ROW SHALL BE VERIFIED IN THE FIELD

TS SHT NO. 10

MODEL: D:\p\Design\K\Illinois\Design\2019\CMAQ\Interconnect\Project\Contract\218615\53\3rc\218615\Rev\Rev-CADD\with-Commissions\112323-Signal.dwg
FILE NAME: S:\P\Design\K\Illinois\Design\2019\CMAQ\Interconnect\Project\Contract\218615\53\3rc\218615\Rev\Rev-CADD\with-Commissions\112323-Signal.dwg

USER NAME = bennettidw	DESIGNED - DB	REVISED -
	DRAWN - DB	REVISED -
PLOT SCALE = 40,0000 * / in.	CHECKED - KK	REVISED -
PLOT DATE = 1/27/2022	DATE - 01/20/2022	REVISED -

**STATE OF ILLINOIS
DEPARTMENT OF TRANSPORTATION**

**TRAFFIC SIGNAL PLAN
WOLF ROAD AT 187TH STREET (MAPLE ROAD)**

SCALE: SHEET OF SHEETS STA. TO STA.

F.A. RTE.	SECTION	COUNTY	TOTAL SHEETS	SHEET NO.
2688	2020-250-BY	COOK & WILL	133	56
ILLINOIS FED. AID PROJECT			CONTRACT NO. 62N20	

**TSW 0139
ECON:**

MODEL: D:\c\... FILE NAME: S:\u\... PROJECTS\Contract\62N2\62N2_SCD\m\11\Revised\CD00\w\h\Dimensions\1st\1st Wolf Road Interconnect.schematic.dwg

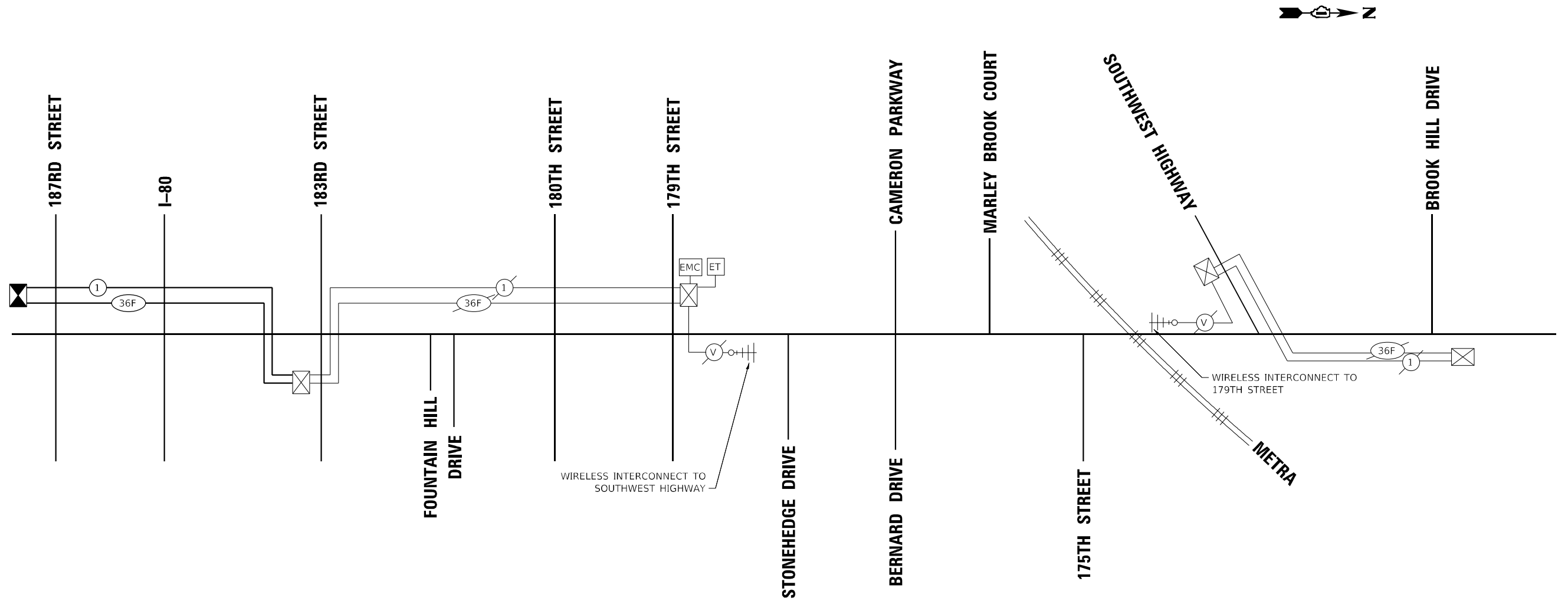

SCHEDULE OF QUANTITIES

ITEM DESCRIPTION	UNITS	TOTAL QTY
UNDERGROUND CONDUIT, GALVANIZED STEEL, 2" DIA.	FOOT	1900
HANDHOLE	EACH	2
HEAVY-DUTY HANDHOLE	EACH	2
MAINTENANCE OF EXISTING TRAFFIC SIGNAL INSTALLATION	EACH	1
TRANSCIVER FIBER OPTIC	EACH	1
ELECTRIC CABLE IN CONDUIT, TRACER, NO. 14 1C	FOOT	2750
DRILL EXISTING HANDHOLE	EACH	2
FIBER OPTIC CABLE IN CONDUIT, NO. 62.5/125, MM12F SM24F	FOOT	2780
RE-OPTIMIZE TRAFFIC SIGNAL SYSTEM LEVEL 2	EACH	1

NOTE:
THE TRAFFIC SIGNAL CONTROLLER EQUIPMENT FOR THIS PROJECT SHALL BE "ECONOLITE" TO MATCH THE EXISTING ADJACENT SYSTEM

SYSTEM SHALL BE OPTIMIZED WITH THE CURRENT SYSTEM OPTIMIZATION OF THE REST OF THE SYSTEM.

ECON: _____

USER NAME = bennettidw	DESIGNED - DB	REVISED -
PLOT SCALE = 40,0000 sf / in.	CHECKED - KK	REVISED -
PLOT DATE = 1/25/2022	DATE - 01/20/2022	REVISED -

**STATE OF ILLINOIS
DEPARTMENT OF TRANSPORTATION**

**PROPOSED INTERCONNECT SCHEMATIC AND SCHEDULE OF QUANTITIES
WOLF ROAD**

SCALE: SHEET OF SHEETS STA. TO STA.

F.A. RTE.	SECTION	COUNTY	TOTAL SHEETS	SHEET NO.
2688	2020-250-BY	COOK & WILL	133	58
CONTRACT NO. 62N20				
ILLINOIS FED. AID PROJECT				

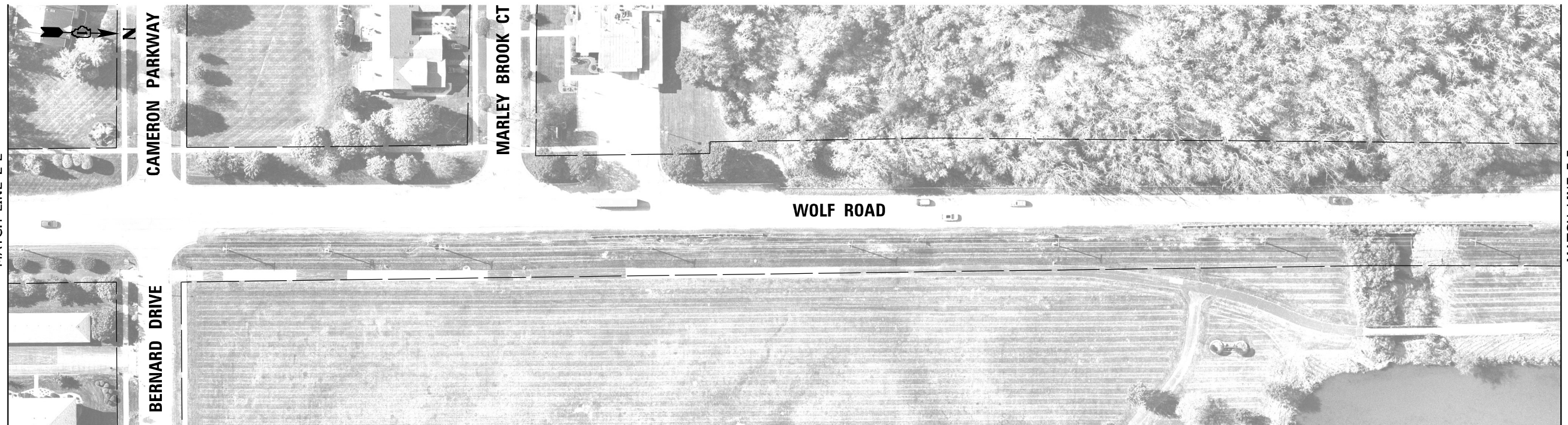
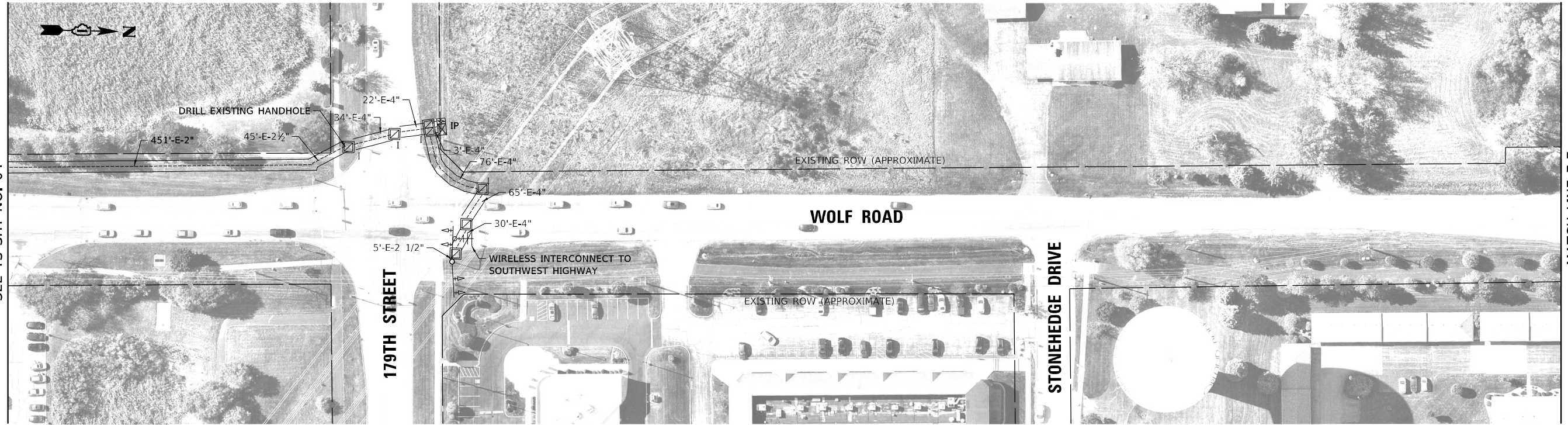

NOTE

- 1. NO WORK ON WOLF ROAD AT THIS SEGMENT

ECON: _____

USER NAME = bennettidw	DESIGNED - DB	REVISED -
	DRAWN - DB	REVISED -
PLOT SCALE = 100,0000' / in.	CHECKED - KK	REVISED -
PLOT DATE = 1/20/2022	DATE - 01/20/2022	REVISED -

**STATE OF ILLINOIS
DEPARTMENT OF TRANSPORTATION**

**INTERCONNECT PLAN
WOLF ROAD**

SCALE: 1"=50' SHEET OF SHEETS STA. TO STA.

F.A. RTE.	SECTION	COUNTY	TOTAL SHEETS	SHEET NO.
2688	2020-250-BY	COOK & WILL	133	61
CONTRACT NO. 62N20			ILLINOIS FED. AID PROJECT	

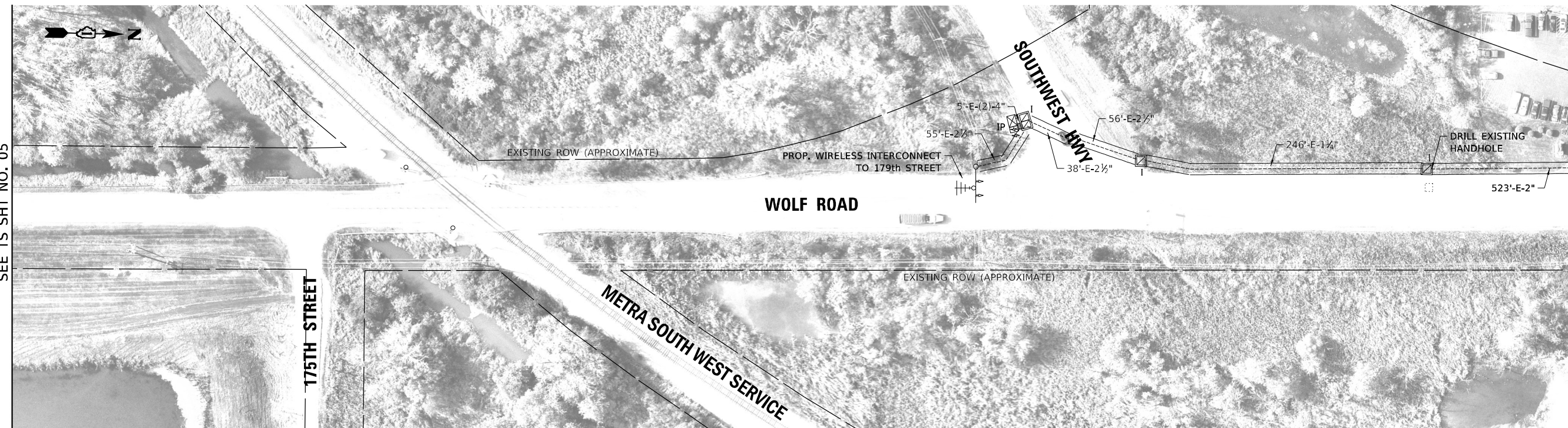

MATCH LINE F-F
SEE TS SHT NO. 05

MATCH LINE G-G
SEE BELOW

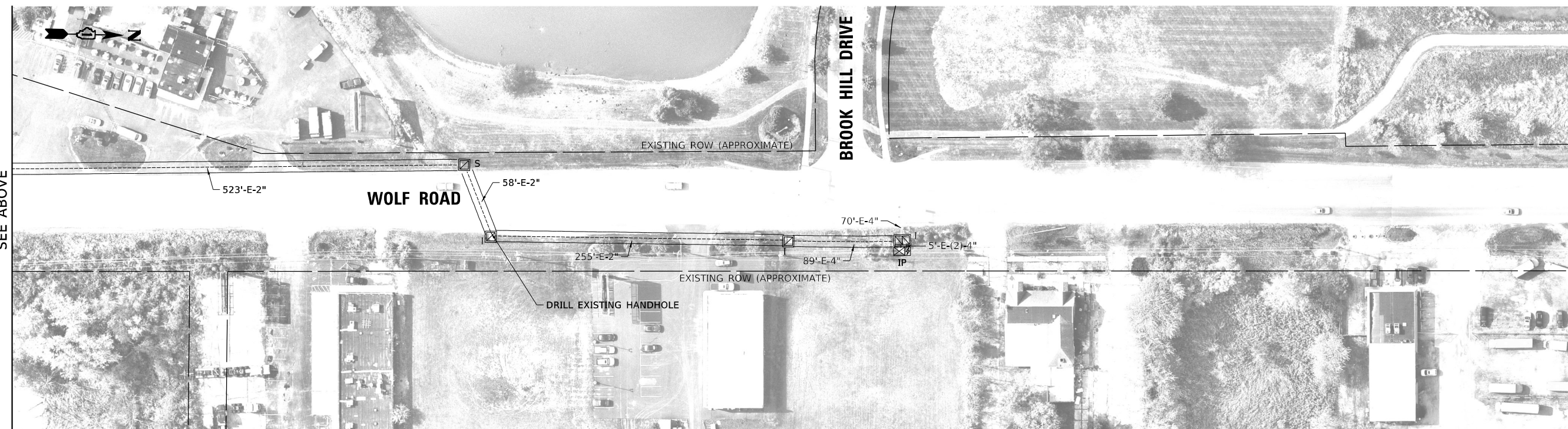

MATCH LINE G-G
SEE ABOVE

TS SHT NO. 16

MODEL: Default
FILE NAME: S:\IP\Design\KCK\In\Hous\Design\2019\CMAQ\Interconnect\Project\Contract\21\615\SE3\Arc\GUT\Review\CADD\with-Commissions\1631\ME\1-18-22\c-d_fires-con\ip-03.dgn

ECON: _____

USER NAME = bennettdw	DESIGNED - DB	REVISED -
	DRAWN - DB	REVISED -
PLOT SCALE = 100,0000' / in.	CHECKED - KK	REVISED -
PLOT DATE = 1/20/2022	DATE - 01/20/2022	REVISED -

STATE OF ILLINOIS
DEPARTMENT OF TRANSPORTATION

PROPOSED INTERCONNECT PLAN
LOCATION D - WOLF ROAD

SCALE: 1"=50' SHEET OF SHEETS STA. TO STA.

F.A. RTE.	SECTION	COUNTY	TOTAL SHEETS	SHEET NO.
2688	2020-250-BY	COOK & WILL	133	62
CONTRACT NO. 62N20				
ILLINOIS		FED. AID PROJECT		

Benchmark: BM #5, Westerly bolt of F.H., Sta. 191+63.24, 53.1' LT, Elev. = 736.06

Existing Structure: S.N. 099-0192 was originally built in 1965, as F.A.I. Route 80 under Section 99-5HB-4. In 1993, the bearings were replaced, the expansion joints were reconstructed, and the deck and substructure were repaired. In 2001, a concrete overlay was added to the bridge deck. In 2007, protective shielding was installed over the I-80 lanes. Concrete barriers were cast around the piers (plans for this work are unavailable). The existing structure is a four-span, reinforced concrete deck on steel girder superstructure with concrete hammerhead piers and stub abutments. The abutments are supported on concrete piles and the piers are supported by spread footings. The structure is 224'-1" back to back abutments and 33'-8" out-to-out deck. Existing deck and steel framing to be replaced and widened to accommodate a shared multi-use path. New concrete deck (composite full length) will be added and the abutments will be converted to semi-integral abutments. Substructure to be widened and repaired.

Traffic Control: Wolf Road will be closed during construction. 3-lanes of traffic to be maintained in each direction on I-80, and traffic to be shifted to the inside/outside shoulders in 2 stages in order to provide a full lane of buffer space during pier and crashwall construction.

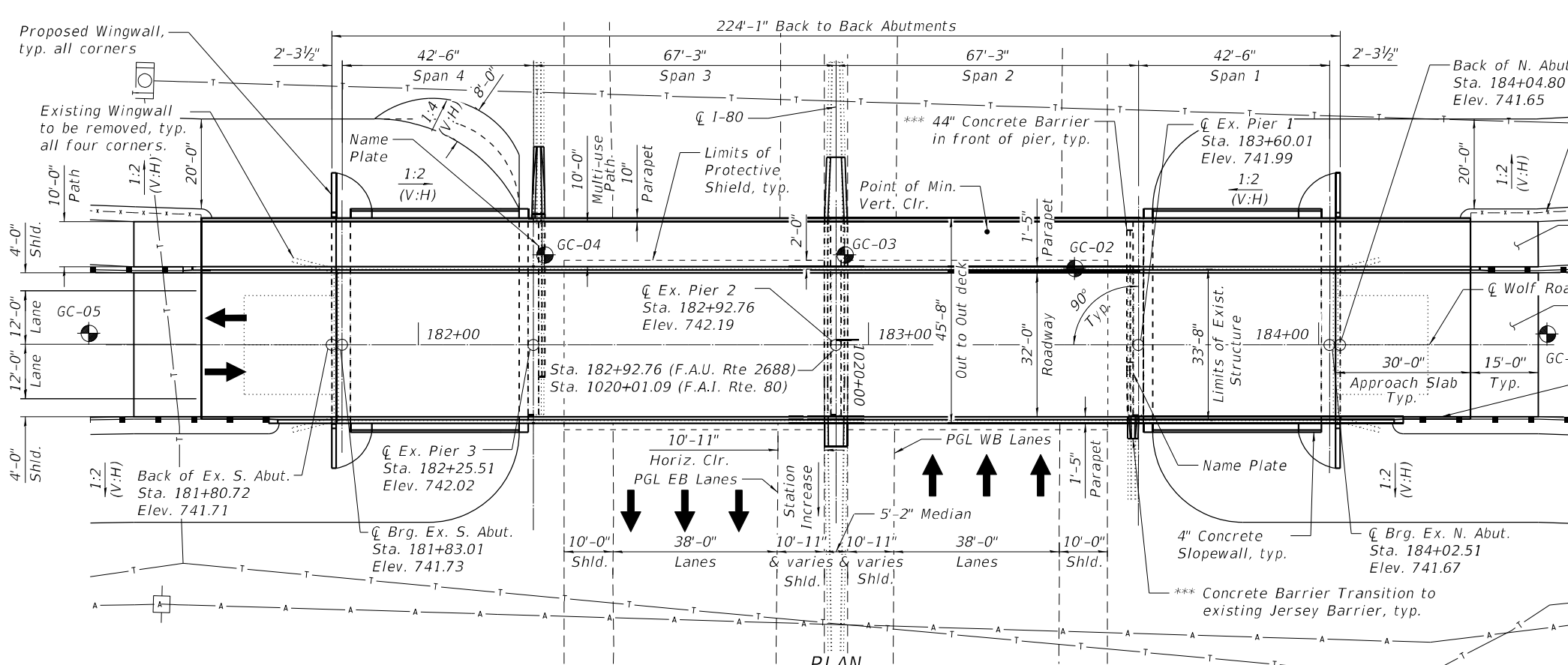
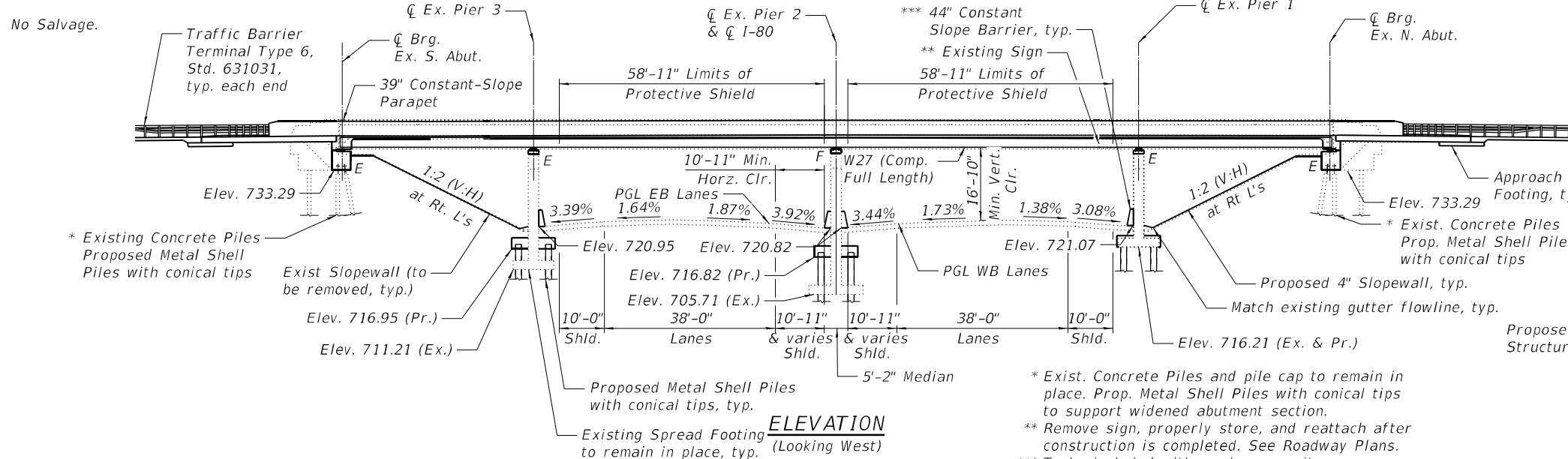

Zaida Morillo
 Licensed Structural Engineer
 State of Illinois 081-008252
 Expires 11/30/2022



DESIGN SPECIFICATIONS

New Construction:
 2020 AASHTO LRFD Bridge Design Specifications, 9th Edition
Existing Piers and Abutments:
 2002 AASHTO Standard Specifications for Highway Bridges, 17th Edition

DESIGN STRESSES

FIELD UNITS (New Construction)
 f'c = 4,000 psi (Superstructure Concrete)
 f'c = 3,500 psi (Substructure Concrete)
 fy = 60,000 psi (Reinforcement)
 fy = 50,000 psi (M270 Grade 50)
FIELD UNITS (Exist. Construction)
 f'c = 3,500 psi
 fy = 40,000 psi (Reinforcement)

LOADING HL-93 (New Construction)
 Allow 50#/sq. ft. for future wearing surface.

SEISMIC DATA

Seismic Performance Zone (SPZ) = 1
 Design Spectral Acceleration at 1.0 sec. (S_{D1}) = 0.066g
 Design Spectral Acceleration at 0.2 sec. (S_{D5}) = 0.122g
 Soil Site Class = C

PROPOSED SCOPE OF WORK

1. Remove existing protective shield and install new protective shield.
2. Remove existing approach slabs, deck, superstructure and bearings.
3. Remove existing wingwalls and backwalls.
4. Remove and replace existing slopewalls.
5. Perform concrete repair and epoxy crack sealing on the existing substructure units.
6. Widen the abutments and piers. Construct new wingwalls. Construct concrete extensions on the abutment and pier caps.
7. Convert existing stub abutments to semi-integral abutments.
8. Install the new bearings and superstructure.
9. Pour new deck, approach slabs and parapets.
10. Install the bridge fence railing and parapet railing.

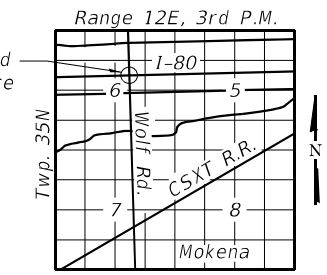

LOCATION SKETCH

LEGEND

- Boring Log
- Existing telephone line
- Existing electric aerial line
- Existing power pole
- Existing manhole

GENERAL PLAN AND ELEVATION

WOLF ROAD OVER I-80
 F.A.U. ROUTE 2688
 SECTION NO. 2020-250-BY
 WILL COUNTY
 STATION 182+92.76
 STRUCTURE NO. 099-0192



USER NAME = kanderson	DESIGNED KJA	REVISED -
CHECKED MGZM	REVISIONS -	
PLOT SCALE =	DRAWN KC	REVISED -
PLOT DATE = 3/19/2022	CHECKED KJA	REVISED -

STATE OF ILLINOIS
DEPARTMENT OF TRANSPORTATION

GENERAL PLAN AND ELEVATION
STRUCTURE NO. 099-0192
 SHEET 1 OF 38 SHEETS

F.A.I. RTE.	SECTION	COUNTY	TOTAL SHEETS	SHEET NO.
80	2020-250-BY	WILL	133	63
CONTRACT NO. 62N20				

MODEL: Default
 FILE NAME: p:\projects\primera\primera\p01\Documents\01 Projects\2020\20200425\01 - IDOT Phase II Various Design\20200425\01_WO_1-3 - Wolf Road over I-80\Drawings\Current Drawing Files\CADD_Sheets\Structural\Wolf Road_SHT02_IndexofSheets & BOM.dgn
 100 S. WACKER DRIVE SUITE 700, CHICAGO IL 60606 - P.312-405-8910 F.312-406-4145
 1/28/2022 3:17:12 PM

GENERAL NOTES

1. Calculated Weight of Structural Steel = 186,800 (Gr 50)
2. All structural steel for beams and splices shall conform to the requirements of AASHTO M270, Grade 50. All other structural steel shall conform to the requirements of AASHTO M270, Grade 36.
3. Fasteners shall be ASTM F 3125 Grade A325 Type 1, mechanically galvanized bolts. Bolts 7/8 in. ϕ , holes 1 1/16 in. ϕ , unless otherwise noted.
4. No old welding is permitted except as specified in the contract documents.
5. Reinforcement bars designated (E) shall be epoxy coated.
6. Plan dimensions and details relative to existing plans are subject to nominal construction variations. The Contractor shall verify existing dimensions and details affecting new construction and make necessary approved adjustments prior to construction or ordering of materials. Such variations shall not be cause for additional compensation for a change in scope of the work, however, the Contractor will be paid for the quantity actually furnished at the unit price bid for the work.
7. Bearing seat surfaces shall be constructed or adjusted to the designated elevations within a tolerance of 1/8 in (0.01 ft.). Adjustment shall be made either by grinding the surface or by shimming the bearings.
8. Concrete Sealer shall be applied to the designated areas of the piers.
9. The existing structural steel coating contains lead. The Contractor shall take appropriate precautions to deal with the presence of lead on this project.
10. The Organic Zinc Rich Primer/Epoxy/Urethane paint system shall be used for painting of new structural steel except where otherwise noted. The entire system shall be shop applied, with the exception that the exterior surfaces and bottom of the bottom angle of the fascia beams, masked connection surfaces, and old installed fasteners, all of which shall be touched up and finish coated in the field. The color of the finish coat for all interior steel surfaces shall be gray, Munsell No. 5B 7/1. The color of the finish coat for the exterior and bottom angle of the fascia shall be Interstate Green, Munsell No. 7.5G 4/8.
11. The embankment configuration shown shall be the minimum that must be placed and compacted prior to construction of the abutments.
12. Slope wall shall be reinforced with welded wire fabric, 6 in x 6in - W4.0 x W4.0, weighing 58 lbs. per 100 sq. ft.
13. Slipforming of the parapets is not allowed.

TOTAL BILL OF MATERIAL

ITEM	UNIT	SUPER	SUB	TOTAL
Removal of Existing Superstructure	L. Sum	1		1
Concrete Removal	Cu. Yd.		33.2	33.2
Sloped Wall Removal	Sq. Yd.		370	370
Protective Shield	Sq. Yd.	598		598
Structure Excavation	Cu. Yd.		226	226
Concrete Structures	Cu. Yd.	22.1	174.8	196.9
Concrete Superstructure	Cu. Yd.	379.0		379.0
Bridge Deck Grooving	Cu. Yd.	941		941
Protective Coat	Sq. Yd.	1,771		1,771
Concrete Superstructure (Approach Slab)	Sq. Yd.	125.8		125.8
Furnishing and Erecting Structural Steel	L. Sum	1		1
Stud Shear Connectors	Each	9,891		9,891
Reinforcement Bars, Epoxy Coated	Pound	154,050	70,370	224,420
Bridge Fence Railing	Foot	278		278
Parapet Railing	Foot	278		278
Slope Wall, 4 inch	Sq. Yd.		478	478
Furnishing Metal Shell Piles 12" x 0.250"	Foot		180	180
Furnishing Metal Shell Piles 16" x 0.375"	Foot		1,218	1,218
Driving Piles	Foot		1,398	1,398
Test Pile, Metal Shells	Each		3	3
Pile Shoes	Each		28	28
Name Plates	Each		1	1
Elastomeric Bearing Assembly, Type I	Each	14		14
Elastomeric Bearing Assembly, Type II	Each	14		14
Anchor Bolts, 5/8"	Each	28		28
Anchor Bolts, 3/4"	Each	42		42
Granular Backfill for Structures	Cu. Yd.		491	491
Concrete Sealer	Sq. Ft.		1,603	1,603
Epoxy Crack Injection	Foot		4	4
Geocomposite Wall Drain	Sq. Yd.		99	99
Pipe Underdrain for Structures 4"	Foot		136	136
Protective Shield Removal	L. Sum	1		1
Removal of Existing Approach Slab	Sq. Yd.	98		98
Structural Repair of Concrete (Depth Equal to or Less Than 5 Inches)	Sq. Yd.		125	125

INDEX OF SHEETS

1. General Plan and Elevation
2. Index of Sheets and Bill of Materials
3. Foundation Plan
4. Removal Plan
5. Top of Deck Plan
6. Top of Deck Elevations I
7. Top of Deck Elevations II
8. Top of Deck Elevations III
9. Top of South Approach Slab Elevations
10. Top of North Approach Slab Elevations
11. Superstructure Plan and Section
12. Parapet Elevation and Details
13. Superstructure Details
14. Diaphragm Details
15. Bridge Fence Railing, Parapet Mounted
16. Parapet Railing
17. Bridge Approach Slab Plan and Section
18. Bridge Approach Slab Details
19. Framing Plan
20. Girder Elevation and Details
21. Girder Moment and Reaction Tables
22. Bearing Details I
23. Bearing Details II
24. North Abutment Plan and Elevation
25. South Abutment Plan and Elevation
26. Abutment Details
27. Pier 1 Widening
28. Pier 2 Widening
29. Pier 3 Widening
30. Pier Repair Details
31. Metal Shell Pile Details
32. Boring Logs I
33. Boring Logs II
34. Boring Logs III
35. Boring Logs IV
36. Boring Logs V
37. Boring Logs VI
38. Boring Logs VII

LIST OF ABBREVIATIONS

N.B.	Northbound
S.B.	Southbound
Sta.	Station
El	Elevation
C.I.P	Cast-in-place
CL	Centerline
S. Abut.	South Abutment
N. Abut.	North Abutment
Typ.	Typical
Max.	Maximum
Min.	Minimum
Bot.	Bottom
Exist./Ex.	Existing
Exp.	Expansion
Shldr	Shoulder
BL	Baseline
P.G.L.	Propile Grade Line
E.F.	Each Face
F.F.	Front Face
B.F.	Back Face
I.F.	Inside Face
O.F.	Outside Face
P.J.F.	Preformed Joint Filler
P.J.S.	Preformed Joint Sealer
Bk/	Back of
B/	Bottom of
T/	Top of
Prop.	Proposed
HP	H-Pile
WF	W-Flange
Cl./Clr.	Clearance
SF	Square Foot
Sq. Ft.	Square Foot
SY	Square Yard
Sq. Yd.	Square Yard
Spa.	Spaced
LF	Linear Feet
Cu. Ft.	Cubic Feet
Ea.	Each
Brg.	Bearing
Horiz.	Horizontal
Vert.	Vertical
Cts.	Centers
Const. Jt.	Construction Joint

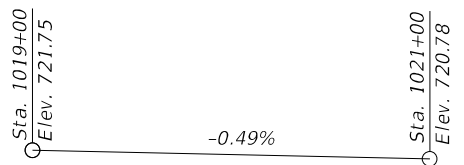
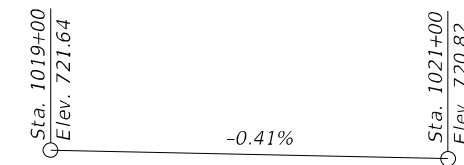
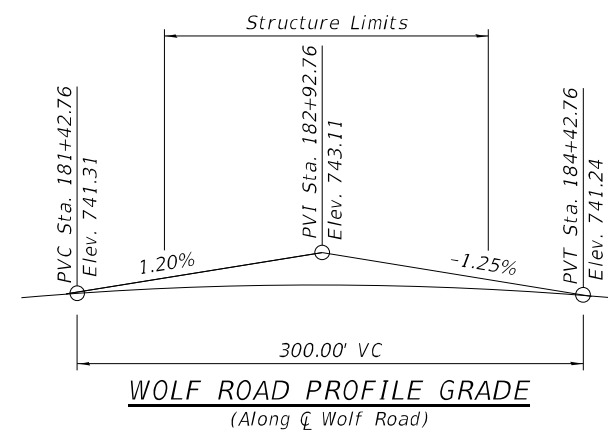
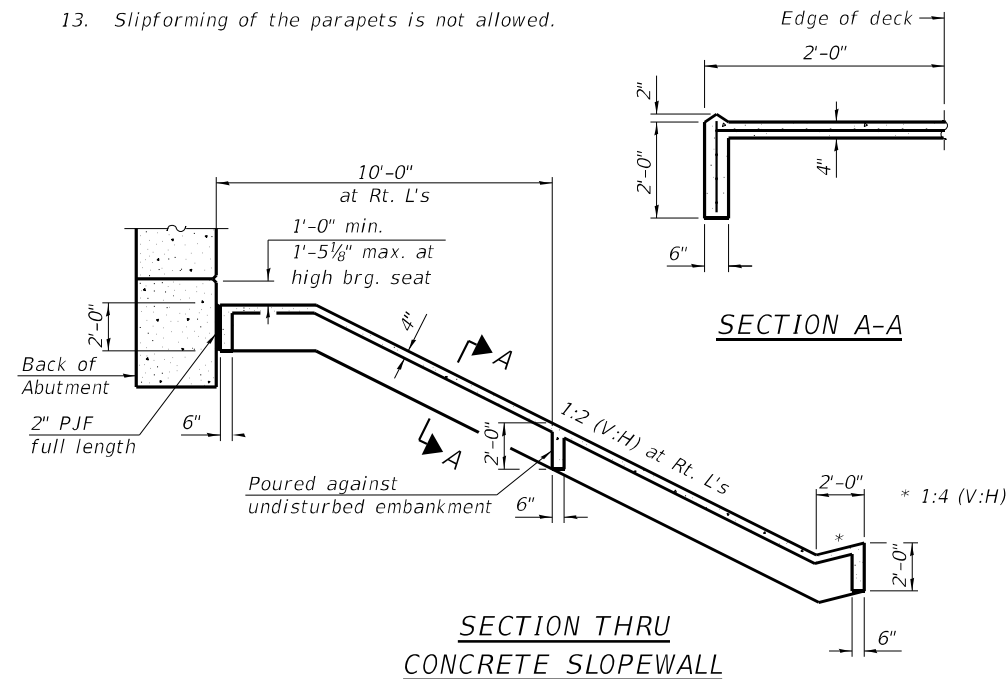

STATION
 RE-BUILT BY
 STATE OF ILLINOIS
 LOADING HL-93
 STRUCTURE NO. 099-0192

NAME PLATE
 See Std. 515001

STATE OF ILLINOIS
DEPARTMENT OF TRANSPORTATION

INDEX OF SHEETS & BILL OF MATERIAL
STRUCTURE NO. 099-0192

SHEET 2 OF 38 SHEETS

F.A.U. RTE.	SECTION	COUNTY	TOTAL SHEETS	SHEET NO.
2688	2020-250-BY	WILL	133	64
ILLINOIS			CONTRACT NO. 62N20	



USER NAME =	rvandermus	DESIGNED	KJA	REVISED	-
CHECKED	MGZM	REVISIONS		REVISED	-
PLOT SCALE =	2.0000" / in.	DRAWN	KC	REVISED	-
PLOT DATE =	1/28/2022	CHECKED	KJA	REVISED	-

MODEL: Default
 FILE NAME: p:\w\primera-pw\benley.com\primera-pw\01\Documents\01\Projects\2020\20200425.00 - IDOT Phase II Various Design\20200425.01_WO_1-3 - Wolf Road over I-80\Drawings\Current Drawing Files\CADD_Sheets\Structural\Wolf Road_SHT03_FoundationPlan.dgn
 100 S. WACKER DRIVE SUITE 700, CHICAGO IL 60606 - P.312-405-8910 F.312-406-4105

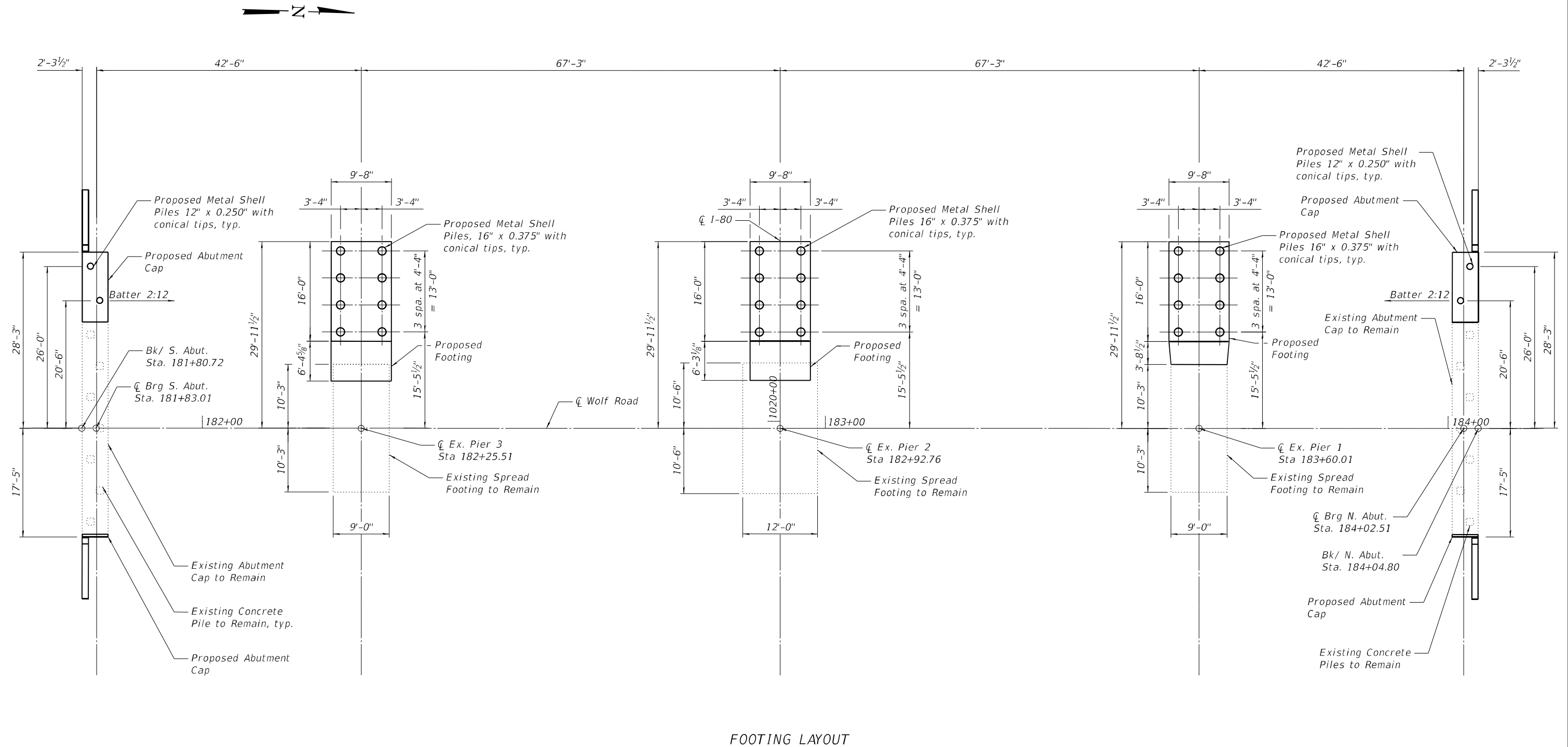

FOOTING LAYOUT



USER NAME =	rvandermus	DESIGNED	KJA	REVISED	-
		CHECKED	MG/ZM	REVISED	-
PLOT SCALE =	16.0000' / in.	DRAWN	KC	REVISED	-
PLOT DATE =	1/28/2022	CHECKED	KJA	REVISED	-

STATE OF ILLINOIS
 DEPARTMENT OF TRANSPORTATION

FOUNDATION PLAN
 STRUCTURE NO. 099-0192

SHEET 3 OF 38 SHEETS

F.A.U. RTE.	SECTION	COUNTY	TOTAL SHEETS	SHEET NO.
2688	2020-250-BY	WILL	133	65
			CONTRACT NO. 62N20	
ILLINOIS				

MODEL: Default
 FILE NAME: p:\pr\primera-pw\ben\key.com\primera-pw\01\Documents\01\Projects\2020\20200425\00 - IDOT Phase II Various Design\2020\20200425\01_WO_1-3 - Wolf Road over I-80\Drawings\Current Drawing Files\CADD_Sheets\Structural\Wolf Road_SHT04_Removal\Plan.dgn
 100 S. WACKER DRIVE SUITE 700, CHICAGO IL 60606 - P.312-405-8919 F.312-406-4145
 1/28/2022 3:17:16 PM

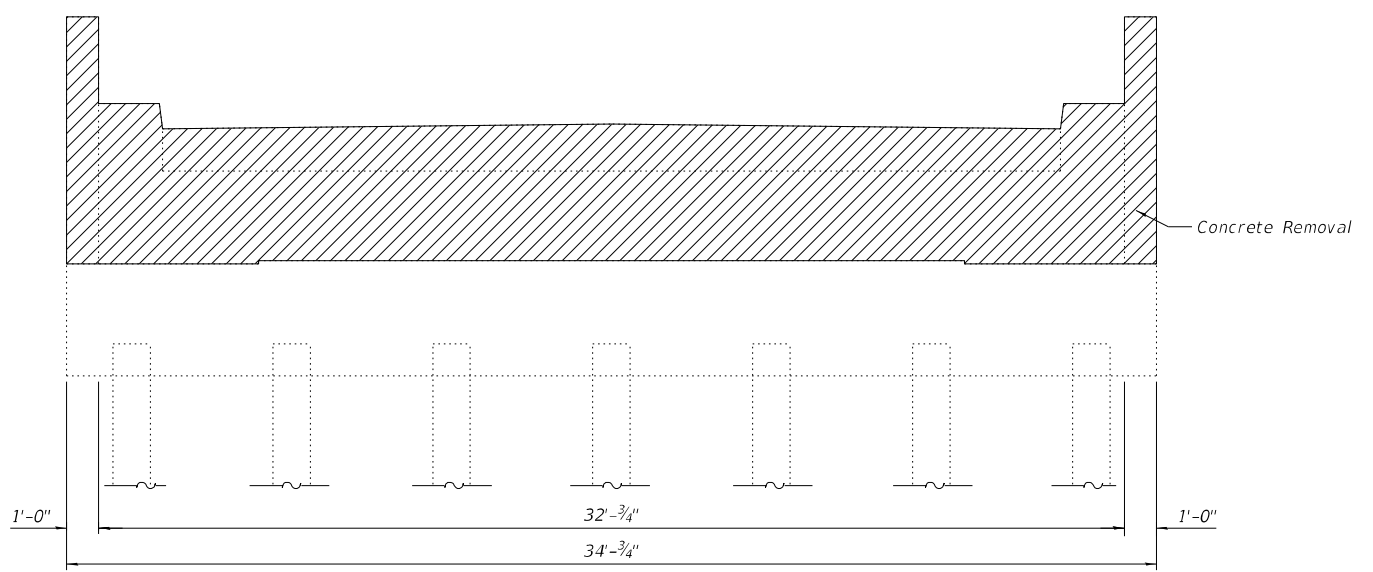

ABUTMENT REMOVAL ELEVATION

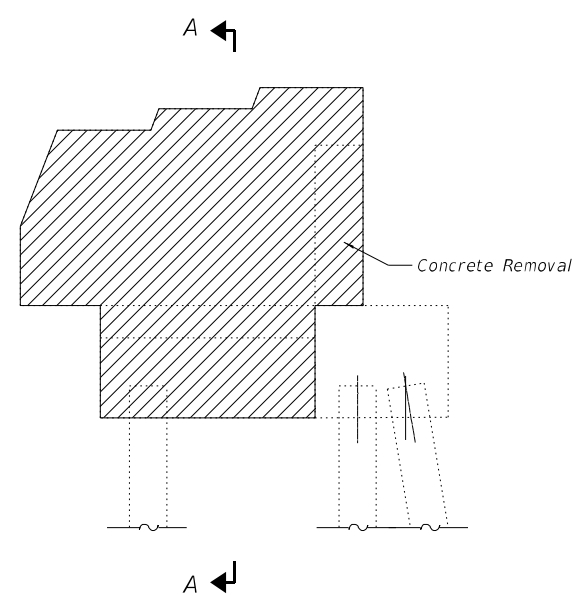

WINGWALL REMOVAL ELEVATION

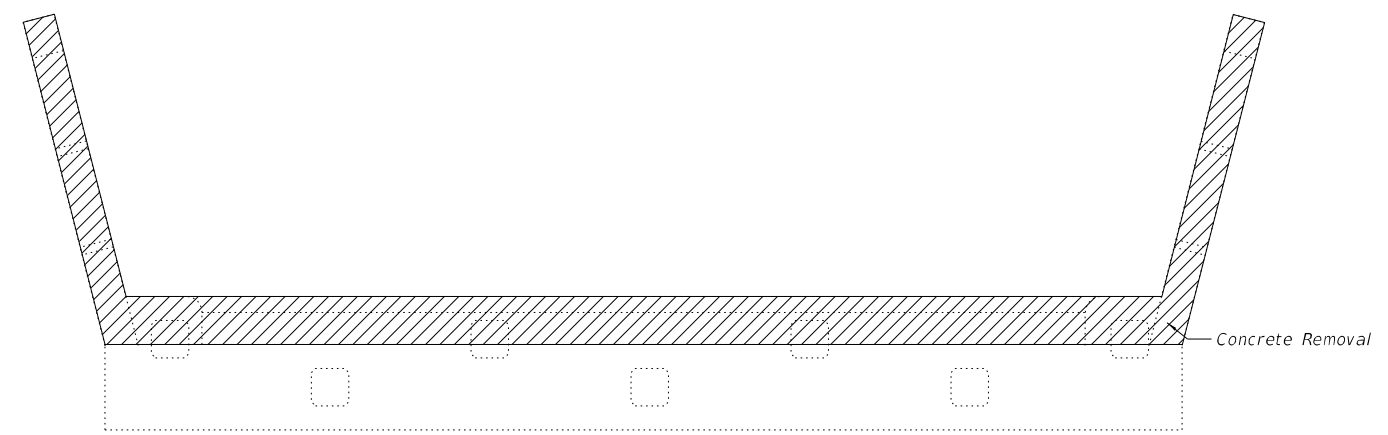

ABUTMENT REMOVAL PLAN

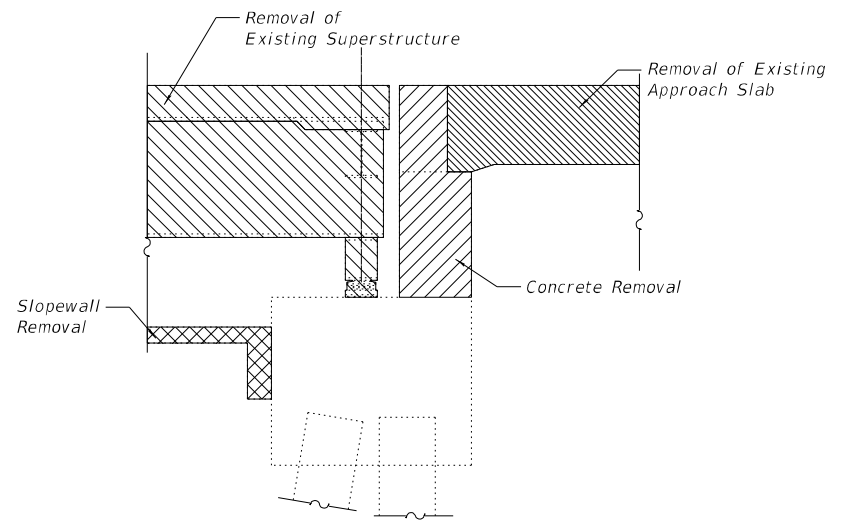

ABUTMENT REMOVAL SECTION

LEGEND

- Concrete Removal
- Removal of Existing Superstructure
- Slope Wall Removal
- Removal of Existing Approach Slab

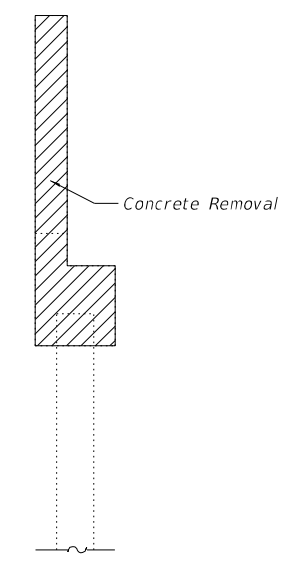

SECTION A-A

TOTAL BILL OF MATERIAL

ITEM	UNIT	TOTAL
Concrete Removal	Cu. Yd.	32.5
Removal of Existing Superstructure	L. Sum	1
Slope Wall Removal	Sq. Yd.	370
Protective Shield	Sq. Yd.	598
Protective Shield Removal	L. Sum	1
Removal of Existing Approach Slab	Sq. Yd.	98



USER NAME =	rvandermus	DESIGNED	KJA	REVISED	-
		CHECKED	MG/ZM	REVISED	-
PLOT SCALE =	12.0000" / in.	DRAWN	KC	REVISED	-
PLOT DATE =	1/28/2022	CHECKED	KJA	REVISED	-

STATE OF ILLINOIS
 DEPARTMENT OF TRANSPORTATION

REMOVAL PLAN
 STRUCTURE NO. 099-0192

SHEET 4 OF 38 SHEETS

F.A.U. RTE.	SECTION	COUNTY	TOTAL SHEETS	SHEET NO.
2688	2020-250-BY	WILL	133	66
			CONTRACT NO. 62N20	
		ILLINOIS		

MODEL: Default
 FILE NAME: p:\pr\primera-pw\ben\key.com\primera-pw\01\Documents\01\Projects\2020\20200425\00 - IDOT Phase II Various Design\20200425_01_WO 1-3 - Wolf Road over I-80\Drawings\Current Drawing Files\CADD_Sheets\Structural\Wolf Road_SHT05_TopofDeckLayout.dgn

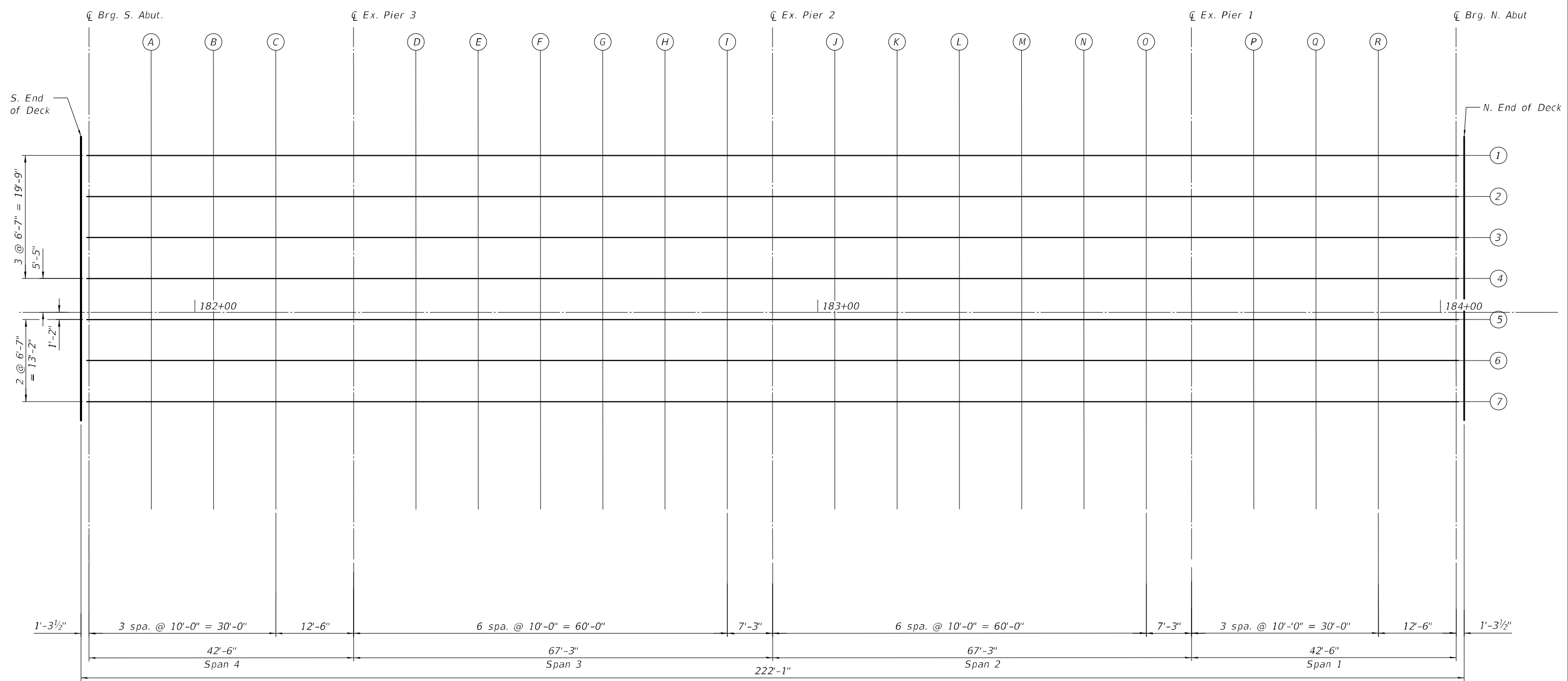
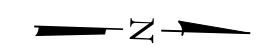

PLAN



USER NAME =	r Vandermus	DESIGNED	KJA	REVISED	-
CHECKED	MG/ZM	REVISED	-		
PLOT SCALE =	16:0" / in.	DRAWN	KC	REVISED	-
PLOT DATE =	1/28/2022	CHECKED	KJA	REVISED	-

**STATE OF ILLINOIS
 DEPARTMENT OF TRANSPORTATION**

**TOP OF DECK PLAN
 STRUCTURE NO. 099-0192**

SHEET 5 OF 38 SHEETS

F.A.U. RTE.	SECTION	COUNTY	TOTAL SHEETS	SHEET NO.
2688	2020-250-BY	WILL	133	67
			CONTRACT NO. 62N20	
ILLINOIS				

MODEL: Default
 FILE NAME: p:\pr\primera-pw\benley.com\primera-pw\01\Documents\01_P\Projects\2020\20200425.00 - IDOT Phase II Various Design\20200425.01_WO_1-3 - Wolf Road over I-80\Drawings\Current Drawing Files\CADD_Sheets\Structural\Wolf Road_SHT05_TopOfDeckElevations.dgn
 100 S. WACKER DRIVE SUITE 700, CHICAGO IL 60606 - P.312-405-8900 F.312-406-4105

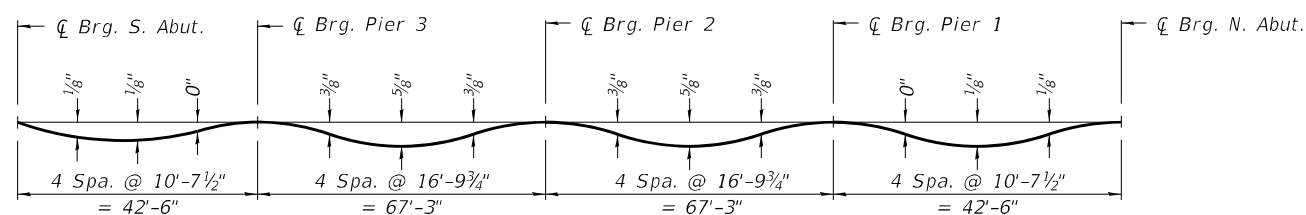

DEAD LOAD DEFLECTION DIAGRAM

(Includes weight of concrete only.)

Note:
 The above deflections are not to be used in the field if the engineer is working from the grade elevations adjusted for dead load deflections as shown below.

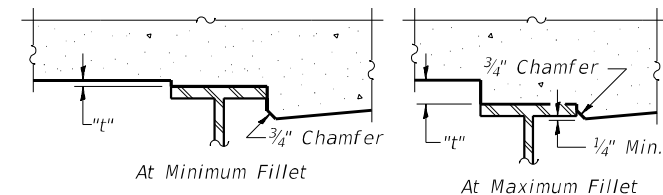

To determine "t": After all structural steel has been erected, elevations of the top angles of the beams shall be taken at intervals shown below. These elevations subtracted from the "Theoretical Grade Elevations Adjusted for Dead Load Deflection" shown below, minus the slab thickness, equals the fillet heights "t" above top angle of beams.

FILLET HEIGHTS

BEAM 1

Location	Station	0 set	Theoretical Grade Elevations	Theoretical Grade Elevations Adjusted For Dead Load Deflection
South End of Deck	181+81.72	-25.17	741.27	741.27
C Brg S Abut	181+83.01	-25.17	741.28	741.28
A	181+93.01	-25.17	741.37	741.38
B	182+03.01	-25.17	741.44	741.45
C	182+13.01	-25.17	741.51	741.51
C Ex. Pier 3	182+25.51	-25.17	741.58	741.58
D	182+35.51	-25.17	741.63	741.65
E	182+45.51	-25.17	741.67	741.72
F	182+55.51	-25.17	741.70	741.77
G	182+65.51	-25.17	741.72	741.79
H	182+75.51	-25.17	741.74	741.78
I	182+85.51	-25.17	741.75	741.76
C Ex. Pier 2	182+92.76	-25.17	741.75	741.75
J	183+02.76	-25.17	741.74	741.76
K	183+12.76	-25.17	741.73	741.77
L	183+22.76	-25.17	741.70	741.77
M	183+32.76	-25.17	741.67	741.74
N	183+42.76	-25.17	741.63	741.68
O	183+52.76	-25.17	741.59	741.60
C Ex. Pier 1	183+60.01	-25.17	741.55	741.55
P	183+70.01	-25.17	741.48	741.49
Q	183+80.01	-25.17	741.42	741.42
R	183+90.01	-25.17	741.34	741.35
C Brg N Abut	184+02.51	-25.17	741.23	741.23
North End of Deck	184+03.80	-25.17	741.22	741.22

BEAM 2

Location	Station	0 set	Theoretical Grade Elevations	Theoretical Grade Elevations Adjusted For Dead Load Deflection
South End of Deck	181+81.72	-18.58	741.40	741.40
C Brg S Abut	181+83.01	-18.58	741.42	741.42
A	181+93.01	-18.58	741.50	741.51
B	182+03.01	-18.58	741.57	741.58
C	182+13.01	-18.58	741.64	741.64
C Ex. Pier 3	182+25.51	-18.58	741.71	741.71
D	182+35.51	-18.58	741.76	741.78
E	182+45.51	-18.58	741.80	741.85
F	182+55.51	-18.58	741.83	741.90
G	182+65.51	-18.58	741.86	741.92
H	182+75.51	-18.58	741.87	741.91
I	182+85.51	-18.58	741.88	741.89
C Ex. Pier 2	182+92.76	-18.58	741.88	741.88
J	183+02.76	-18.58	741.87	741.89
K	183+12.76	-18.58	741.86	741.90
L	183+22.76	-18.58	741.84	741.90
M	183+32.76	-18.58	741.80	741.87
N	183+42.76	-18.58	741.77	741.81
O	183+52.76	-18.58	741.72	741.73
C Ex. Pier 1	183+60.01	-18.58	741.68	741.68
P	183+70.01	-18.58	741.62	741.62
Q	183+80.01	-18.58	741.55	741.55
R	183+90.01	-18.58	741.47	741.48
C Brg N Abut	184+02.51	-18.58	741.36	741.36
North End of Deck	184+03.80	-18.58	741.35	741.35

BEAM 3

Location	Station	0 set	Theoretical Grade Elevations	Theoretical Grade Elevations Adjusted For Dead Load Deflection
South End of Deck	181+81.72	-12.00	741.54	741.54
C Brg S Abut	181+83.01	-12.00	741.55	741.55
A	181+93.01	-12.00	741.63	741.64
B	182+03.01	-12.00	741.70	741.71
C	182+13.01	-12.00	741.77	741.77
C Ex. Pier 3	182+25.51	-12.00	741.84	741.84
D	182+35.51	-12.00	741.89	741.91
E	182+45.51	-12.00	741.93	741.98
F	182+55.51	-12.00	741.96	742.03
G	182+65.51	-12.00	741.99	742.05
H	182+75.51	-12.00	742.00	742.04
I	182+85.51	-12.00	742.01	742.02
C Ex. Pier 2	182+92.76	-12.00	742.01	742.01
J	183+02.76	-12.00	742.00	742.02
K	183+12.76	-12.00	741.99	742.03
L	183+22.76	-12.00	741.97	742.03
M	183+32.76	-12.00	741.94	742.00
N	183+42.76	-12.00	741.90	741.94
O	183+52.76	-12.00	741.85	741.86
C Ex. Pier 1	183+60.01	-12.00	741.81	741.81
P	183+70.01	-12.00	741.75	741.75
Q	183+80.01	-12.00	741.68	741.69
R	183+90.01	-12.00	741.60	741.61
C Brg N Abut	184+02.51	-12.00	741.49	741.49
North End of Deck	184+03.80	-12.00	741.48	741.48



USER NAME =	rvaidermus	DESIGNED	KJA	REVISED	-
CHECKED	MGZM	REVISED	-		
PLOT SCALE =	2.0000' / in.	DRAWN	KC	REVISED	-
PLOT DATE =	1/28/2022	CHECKED	KJA	REVISED	-

STATE OF ILLINOIS
DEPARTMENT OF TRANSPORTATION

TOP OF DECK ELEVATIONS I
STRUCTURE NO. 099-0192

SHEET 6 OF 38 SHEETS

F.A.U. RTE.	SECTION	COUNTY	TOTAL SHEETS	SHEET NO.
2688	2020-250-BY	WILL	133	68
ILLINOIS			CONTRACT NO. 62N20	

MODEL: Default
 FILE NAME: p:\w\primera-pw\ben\key.com\primera-pw\01\Documents\01\Projects\2020\20200425\00 - IDOT Phase II Various Design\20200425\01_WO_1-3 - Wolf Road over I-80\Drawings\Current Drawing Files\CADD_Sheets\Structural\Wolf Road_SHT07_TopofDeckElevations.dgn
 100 S. WACKER DRIVE SUITE 700, CHICAGO IL 60606 - P:312-405-8900 F:312-406-4105

BEAM 4

Location	Station	0 set	Theoretical Grade Elevations	Theoretical Grade Elevations Adjusted For Dead Load De ection
South End of Deck	181+81.72	-5.42	741.63	741.63
C Brg S Abut	181+83.01	-5.42	741.65	741.65
A	181+93.01	-5.42	741.73	741.74
B	182+03.01	-5.42	741.80	741.81
C	182+13.01	-5.42	741.87	741.87
C Ex. Pier 3	182+25.51	-5.42	741.94	741.94
D	182+35.51	-5.42	741.99	742.01
E	182+45.51	-5.42	742.03	742.08
F	182+55.51	-5.42	742.06	742.13
G	182+65.51	-5.42	742.09	742.15
H	182+75.51	-5.42	742.10	742.14
I	182+85.51	-5.42	742.11	742.12
C Ex. Pier 2	182+92.76	-5.42	742.11	742.11
J	183+02.76	-5.42	742.10	742.12
K	183+12.76	-5.42	742.09	742.13
L	183+22.76	-5.42	742.07	742.13
M	183+32.76	-5.42	742.03	742.10
N	183+42.76	-5.42	742.00	742.04
O	183+52.76	-5.42	741.95	741.96
C Ex. Pier 1	183+60.01	-5.42	741.91	741.91
P	183+70.01	-5.42	741.85	741.85
Q	183+80.01	-5.42	741.78	741.79
R	183+90.01	-5.42	741.70	741.71
C Brg N Abut	184+02.51	-5.42	741.59	741.59
North End of Deck	184+03.80	-5.42	741.58	741.58

PGL

Location	Station	0 set	Theoretical Grade Elevations	Theoretical Grade Elevations Adjusted For Dead Load De ection
South End of Deck	181+81.72	0.00	741.72	741.72
C Brg S Abut	181+83.01	0.00	741.73	741.73
A	181+93.01	0.00	741.81	741.82
B	182+03.01	0.00	741.88	741.89
C	182+13.01	0.00	741.95	741.95
C Ex. Pier 3	182+25.51	0.00	742.02	742.02
D	182+35.51	0.00	742.07	742.09
E	182+45.51	0.00	742.11	742.16
F	182+55.51	0.00	742.14	742.21
G	182+65.51	0.00	742.17	742.23
H	182+75.51	0.00	742.18	742.22
I	182+85.51	0.00	742.19	742.20
C Ex. Pier 2	182+92.76	0.00	742.19	742.19
J	183+02.76	0.00	742.18	742.20
K	183+12.76	0.00	742.17	742.21
L	183+22.76	0.00	742.15	742.21
M	183+32.76	0.00	742.12	742.18
N	183+42.76	0.00	742.08	742.12
O	183+52.76	0.00	742.03	742.04
C Ex. Pier 1	183+60.01	0.00	741.99	741.99
P	183+70.01	0.00	741.93	741.93
Q	183+80.01	0.00	741.86	741.87
R	183+90.01	0.00	741.78	741.79
C Brg N Abut	184+02.51	0.00	741.67	741.67
North End of Deck	184+03.80	0.00	741.66	741.66

BEAM 5

Location	Station	0 set	Theoretical Grade Elevations	Theoretical Grade Elevations Adjusted For Dead Load De ection
South End of Deck	181+81.72	1.17	741.70	741.70
C Brg S Abut	181+83.01	1.17	741.71	741.71
A	181+93.01	1.17	741.79	741.80
B	182+03.01	1.17	741.87	741.88
C	182+13.01	1.17	741.93	741.94
C Ex. Pier 3	182+25.51	1.17	742.01	742.01
D	182+35.51	1.17	742.05	742.08
E	182+45.51	1.17	742.09	742.14
F	182+55.51	1.17	742.13	742.19
G	182+65.51	1.17	742.15	742.21
H	182+75.51	1.17	742.17	742.20
I	182+85.51	1.17	742.17	742.18
C Ex. Pier 2	182+92.76	1.17	742.17	742.17
J	183+02.76	1.17	742.17	742.18
K	183+12.76	1.17	742.15	742.20
L	183+22.76	1.17	742.13	742.19
M	183+32.76	1.17	742.10	742.16
N	183+42.76	1.17	742.06	742.10
O	183+52.76	1.17	742.01	742.03
C Ex. Pier 1	183+60.01	1.17	741.97	741.97
P	183+70.01	1.17	741.91	741.91
Q	183+80.01	1.17	741.84	741.85
R	183+90.01	1.17	741.76	741.77
C Brg N Abut	184+02.51	1.17	741.65	741.65
North End of Deck	184+03.80	1.17	741.64	741.64



USER NAME =	rvandermus	DESIGNED	KJA	REVISED	-
		CHECKED	MG/ZM	REVISED	-
PLOT SCALE =	2.0000' / in.	DRAWN	KC	REVISED	-
PLOT DATE =	1/28/2022	CHECKED	KJA	REVISED	-

**STATE OF ILLINOIS
 DEPARTMENT OF TRANSPORTATION**

**TOP OF DECK ELEVATIONS II
 STRUCTURE NO. 099-0192**

SHEET 7 OF 38 SHEETS

F.A.U. RTE.	SECTION	COUNTY	TOTAL SHEETS	SHEET NO.
2688	2020-250-BY	WILL	133	69
			CONTRACT NO. 62N20	
			ILLINOIS	

MODEL: Default
 FILE NAME: p:\w\primera-pw\ben\ky.com\primera-pw\01\Documents\01\Projects\2020\20200425\00 - IDOT Phase II Various Design\20200425\01_WO_1-3 - Wolf Road over I-80\Drawings\Current Drawing Files\CADD_Sheets\Structural\Wolf Road_SHT08_TopofDeckElevations\Ill.dgn
 100 S. WACKER DRIVE SUITE 700, CHICAGO IL 60606 - P:312-405-8900 F:312-406-4105

BEAM 6

Location	Station	0 set	Theoretical Grade Elevations	Theoretical Grade Elevations Adjusted For Dead Load De ection
South End of Deck	181+81.72	7.75	741.60	741.60
☒ Brg S Abut	181+83.01	7.75	741.61	741.61
A	181+93.01	7.75	741.69	741.70
B	182+03.01	7.75	741.77	741.78
C	182+13.01	7.75	741.84	741.84
☒ Ex. Pier 3	182+25.51	7.75	741.91	741.91
D	182+35.51	7.75	741.96	741.98
E	182+45.51	7.75	742.00	742.05
F	182+55.51	7.75	742.03	742.09
G	182+65.51	7.75	742.05	742.11
H	182+75.51	7.75	742.07	742.10
I	182+85.51	7.75	742.07	742.08
☒ Ex. Pier 2	182+92.76	7.75	742.08	742.08
J	183+02.76	7.75	742.07	742.08
K	183+12.76	7.75	742.05	742.10
L	183+22.76	7.75	742.03	742.09
M	183+32.76	7.75	742.00	742.06
N	183+42.76	7.75	741.96	742.00
O	183+52.76	7.75	741.91	741.93
☒ Ex. Pier 1	183+60.01	7.75	741.87	741.87
P	183+70.01	7.75	741.81	741.81
Q	183+80.01	7.75	741.74	741.75
R	183+90.01	7.75	741.66	741.67
☒ Brg N Abut	184+02.51	7.75	741.56	741.56
North End of Deck	184+03.80	7.75	741.54	741.54

BEAM 7

Location	Station	0 set	Theoretical Grade Elevations	Theoretical Grade Elevations Adjusted For Dead Load De ection
South End of Deck	181+81.72	14.33	741.49	741.49
☒ Brg S Abut	181+83.01	14.33	741.50	741.50
A	181+93.01	14.33	741.58	741.59
B	182+03.01	14.33	741.66	741.67
C	182+13.01	14.33	741.72	741.73
☒ Ex. Pier 3	182+25.51	14.33	741.80	741.80
D	182+35.51	14.33	741.85	741.87
E	182+45.51	14.33	741.89	741.94
F	182+55.51	14.33	741.92	741.99
G	182+65.51	14.33	741.94	742.00
H	182+75.51	14.33	741.96	742.00
I	182+85.51	14.33	741.96	741.97
☒ Ex. Pier 2	182+92.76	14.33	741.96	741.96
J	183+02.76	14.33	741.96	741.98
K	183+12.76	14.33	741.94	741.99
L	183+22.76	14.33	741.92	741.99
M	183+32.76	14.33	741.89	741.96
N	183+42.76	14.33	741.85	741.90
O	183+52.76	14.33	741.80	741.82
☒ Ex. Pier 1	183+60.01	14.33	741.76	741.76
P	183+70.01	14.33	741.70	741.70
Q	183+80.01	14.33	741.63	741.64
R	183+90.01	14.33	741.55	741.56
☒ Brg N Abut	184+02.51	14.33	741.45	741.45
North End of Deck	184+03.80	14.33	741.43	741.43



USER NAME =	rvandermus	DESIGNED	KJA	REVISED	-
CHECKED	MG/ZM	REVISED	-		
PLOT SCALE =	2.0000" / in.	DRAWN	KC	REVISED	-
PLOT DATE =	1/28/2022	CHECKED	KJA	REVISED	-

**STATE OF ILLINOIS
 DEPARTMENT OF TRANSPORTATION**

**TOP OF DECK ELEVATIONS III
 STRUCTURE NO. 099-0192**

SHEET 8 OF 38 SHEETS

F.A.U. RTE.	SECTION	COUNTY	TOTAL SHEETS	SHEET NO.
2688	2020-250-BY	WILL	133	70
			CONTRACT NO. 62N20	
		ILLINOIS		

MODEL: Default
 FILE NAME: p:\w\primera-pw\ben\key.com\primera-pw\01\Documents\01\Projects\2020\20200425\00 - IDOT Phase II Various Design\20200425\01_WO_1-3 - Wolf Road over I-80\Drawings\Current Drawing Files\CADD_Sheets\Structural\Wolf Road_SHT09_TopofSouthApproachSlabElevations.dgn
 100 S. WACKER DRIVE SUITE 700, CHICAGO IL 60606 - P.312-405-8900 F.312-406-4145

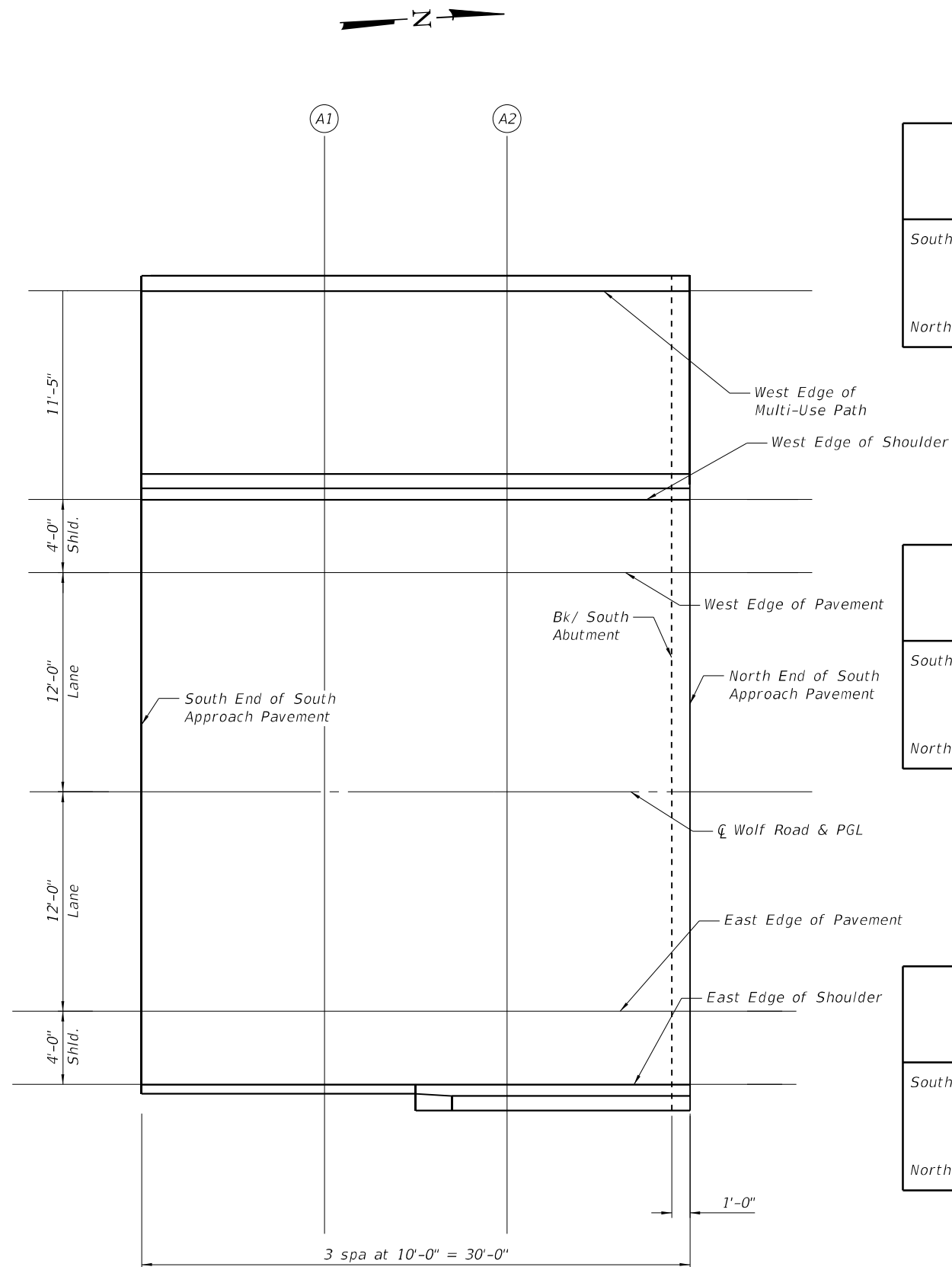

PLAN

WEST EDGE OF MULTI-USE PATH

Location	Station	0 set (ft)	Theoretical Grade Elevations
South End South Appr. Pav't.	181+51.72	-27.42	740.92
A1	181+61.72	-27.42	741.03
A2	181+71.72	-27.42	741.13
North End South Appr. Pav't.	181+81.72	-27.42	741.23

WOLF ROAD & PROFILE GRADE

Location	Station	0 set (ft)	Theoretical Grade Elevations
South End South Appr. Pav't.	181+51.72	0.00	741.41
A1	181+61.72	0.00	741.52
A2	181+71.72	0.00	741.62
North End South Appr. Pav't.	181+81.72	0.00	741.72

WEST EDGE OF SHOULDER

Location	Station	0 set (ft)	Theoretical Grade Elevations
South End South Appr. Pav't.	181+51.72	-16.00	741.15
A1	181+61.72	-16.00	741.26
A2	181+71.72	-16.00	741.36
North End South Appr. Pav't.	181+81.72	-16.00	741.46

EAST EDGE OF PAVEMENT

Location	Station	0 set (ft)	Theoretical Grade Elevations
South End South Appr. Pav't.	181+51.72	12.00	741.23
A1	181+61.72	12.00	741.34
A2	181+71.72	12.00	741.44
North End South Appr. Pav't.	181+81.72	12.00	741.54

WEST EDGE OF PAVEMENT

Location	Station	0 set (ft)	Theoretical Grade Elevations
South End South Appr. Pav't.	181+51.72	-12.00	741.23
A1	181+61.72	-12.00	741.34
A2	181+71.72	-12.00	741.44
North End South Appr. Pav't.	181+81.72	-12.00	741.54

EAST EDGE OF SHOULDER

Location	Station	0 set (ft)	Theoretical Grade Elevations
South End South Appr. Pav't.	181+51.72	16.00	741.15
A1	181+61.72	16.00	741.26
A2	181+71.72	16.00	741.36
North End South Appr. Pav't.	181+81.72	16.00	741.46

MODEL: Default
 FILE NAME: p:\w\primera-pw\ben\k\Documents\01 Projects\2020\20200425\01 - IDOT Phase II Various Design\01 Drawings\Current Drawing Files\CADD_Sheets\Structural\Wolf Road_SHT 10_Topo\ApproachSlabElevations.dgn
 100 S. WACKER DRIVE SUITE 700, CHICAGO IL 60606 - P.312-405-8910 F.312-406-4145

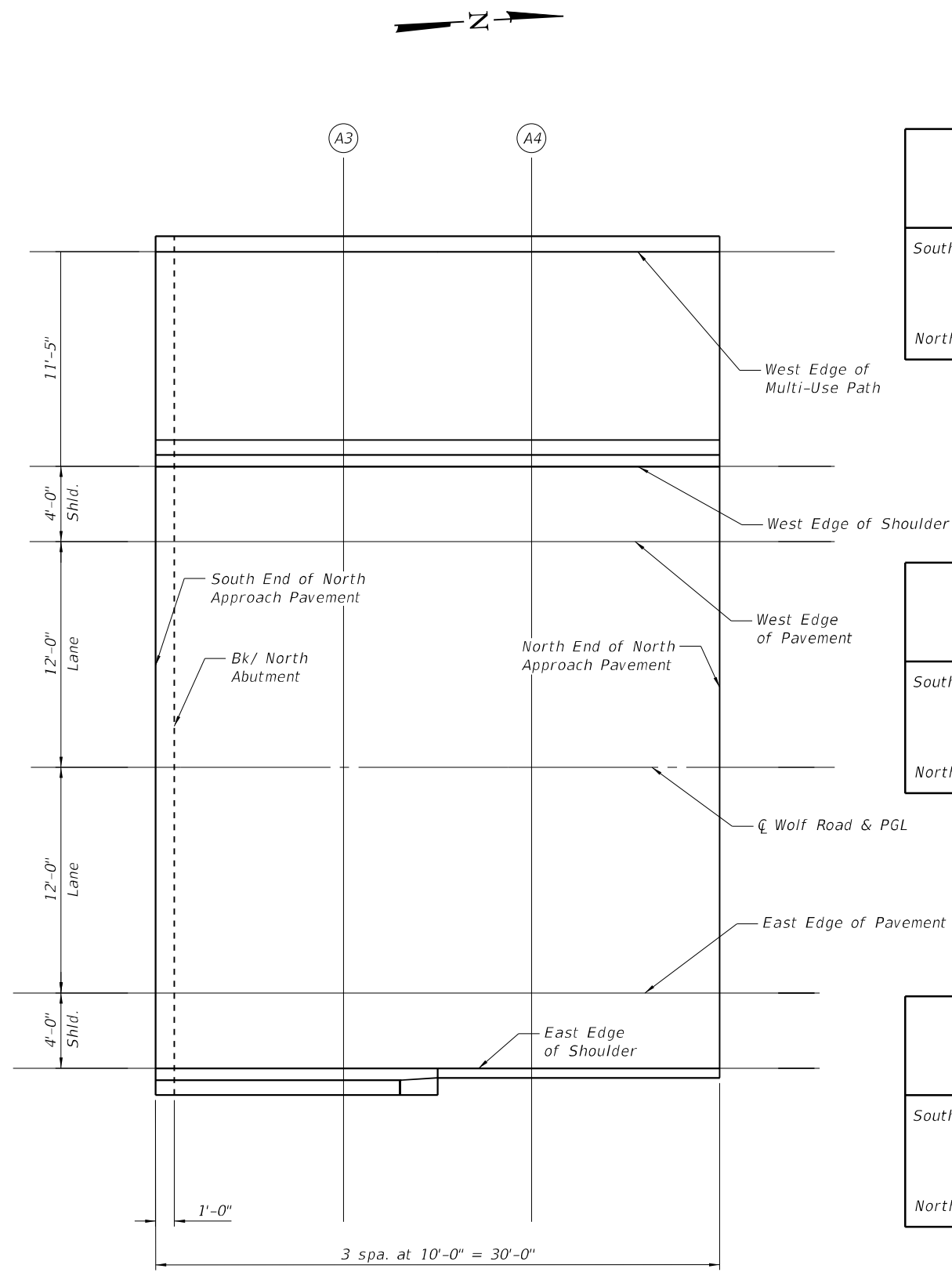

PLAN

WEST EDGE OF MULTI-USE PATH

Location	Station	0 set (ft)	Theoretical Grade Elevations
South End North Appr. Pav't.	184+03.80	-27.42	741.17
A3	184+13.80	-27.42	741.07
A4	184+23.80	-27.42	740.97
North End North Appr. Pav't.	184+33.80	-27.42	740.85

☉ WOLF ROAD & PROFILE GRADE

Location	Station	0 set (ft)	Theoretical Grade Elevations
South End North Appr. Pav't.	184+03.80	0.00	741.66
A3	184+13.80	0.00	741.56
A4	184+23.80	0.00	741.46
North End North Appr. Pav't.	184+33.80	0.00	741.34

WEST EDGE OF SHOULDER

Location	Station	0 set (ft)	Theoretical Grade Elevations
South End North Appr. Pav't.	184+03.80	-16.00	741.40
A3	184+13.80	-16.00	741.30
A4	184+23.80	-16.00	741.20
North End North Appr. Pav't.	184+33.80	-16.00	741.08

EAST EDGE OF PAVEMENT

Location	Station	0 set (ft)	Theoretical Grade Elevations
South End North Appr. Pav't.	184+03.80	12.00	741.48
A3	184+13.80	12.00	741.38
A4	184+23.80	12.00	741.28
North End North Appr. Pav't.	184+33.80	12.00	741.16

WEST EDGE OF PAVEMENT

Location	Station	0 set (ft)	Theoretical Grade Elevations
South End North Appr. Pav't.	184+03.80	-12.00	741.48
A3	184+13.80	-12.00	741.38
A4	184+23.80	-12.00	741.28
North End North Appr. Pav't.	184+33.80	-12.00	741.16

EAST EDGE OF SHOULDER

Location	Station	0 set (ft)	Theoretical Grade Elevations
South End North Appr. Pav't.	184+03.80	16.00	741.40
A3	184+13.80	16.00	741.30
A4	184+23.80	16.00	741.20
North End North Appr. Pav't.	184+33.80	16.00	741.08

STATE OF ILLINOIS
 DEPARTMENT OF TRANSPORTATION

TOP OF NORTH APPROACH SLAB ELEVATIONS
 STRUCTURE NO. 099-0192

SHEET 10 OF 38 SHEETS

F.A.U. RTE.	SECTION	COUNTY	TOTAL SHEETS	SHEET NO.
2688	2020-250-BY	WILL	133	72
CONTRACT NO. 62N20				



USER NAME =	rvandermus	DESIGNED	KJA	REVISED	-
CHECKED	MG/ZM	REVISED	-		
PLOT SCALE =	8.0000" / in.	DRAWN	KC	REVISED	-
PLOT DATE =	1/28/2022	CHECKED	KJA	REVISED	-

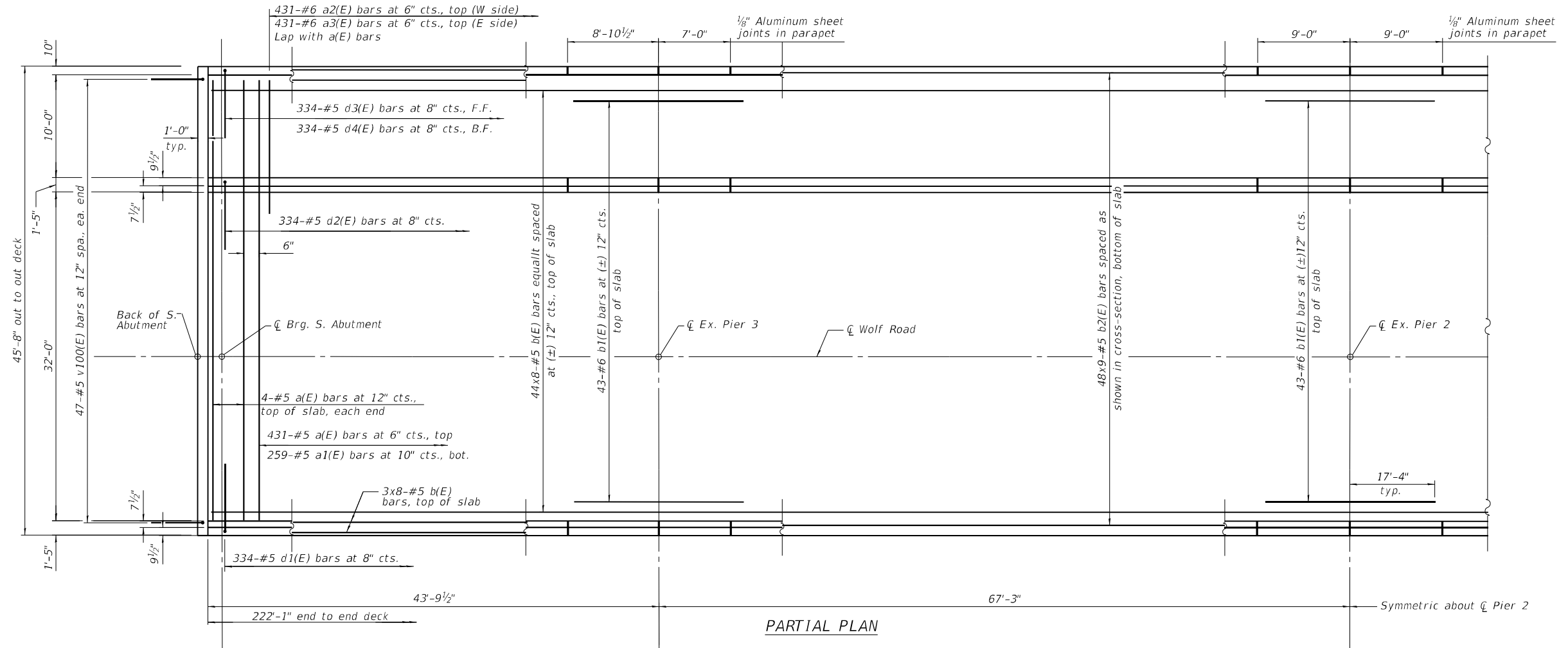

PARTIAL PLAN

MINIMUM BAR LAP

#5 bar = 3'-6"
#6 bar = 4'-10"

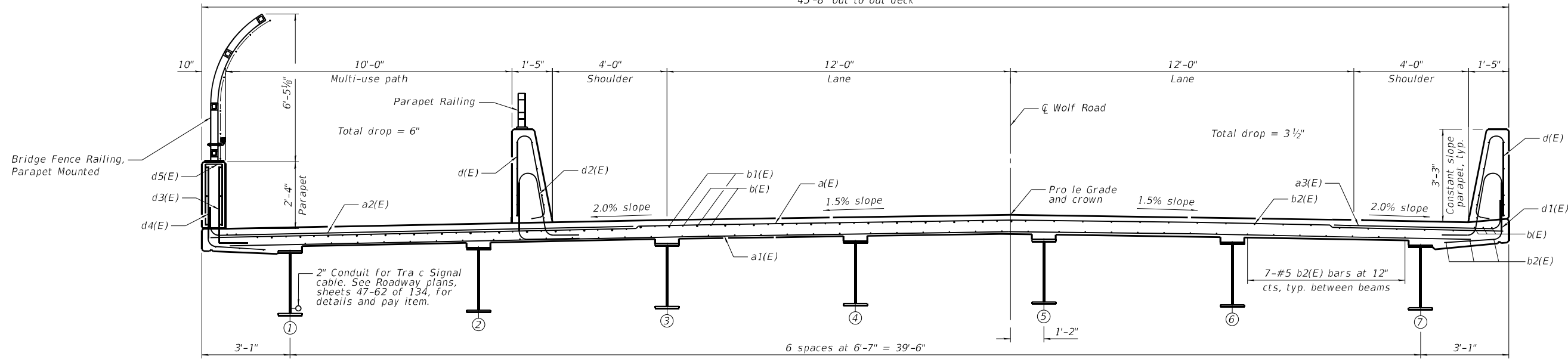

NEAR PIER

CROSS-SECTION
(Looking North)

NEAR MIDSPAN

Notes:
See sheet 13 of 38 for superstructure details and Bill of Materials.
Bars indicated thus 20x3-#5 etc. indicates 20 lines of bars with 3 lengths per line

MODEL: Default
FILE NAME: p:\pr\primera-pw\ben\key.com\primera-pw\01\Documents\01 Projects\2020\20200425\00 - IDOT Phase II Various Design\20200425\01_WO_1-3 - Wolf Road over I-80\Drawings\Current Drawing Files\CADD_Sheets\Structural\Wolf Road_SHT11_SuperstructurePlan&Section.dgn
100 S. WACKER DRIVE SUITE 700, CHICAGO IL 60606 - P.312-605-8919 F.312-606-4105
1/28/2022 3:17:24 PM



USER NAME =	rvandermus	DESIGNED	KJA	REVISED	-
PLOT SCALE =	12.0000' / in.	CHECKED	MG	REVISED	-
PLOT DATE =	1/28/2022	DRAWN	MG	REVISED	-
		CHECKED	KJA	REVISED	-

STATE OF ILLINOIS
DEPARTMENT OF TRANSPORTATION

SUPERSTRUCTURE PLAN AND SECTION
STRUCTURE NO. 099-0192

SHEET 11 OF 38 SHEETS

F.A.U. RTE.	SECTION	COUNTY	TOTAL SHEETS	SHEET NO.
2688	2020-250-BY	WILL	133	73
ILLINOIS			CONTRACT NO. 62N20	

MODEL: Default
 FILE NAME: p:\w\primera-pw\ben\key.com\primera-pw\01\Documents\01\Projects\2020\20200425\00 - IDOT Phase II Various Design\2020\20200425\01_WO_1-3 - Wolf Road over I-80\Drawings\Current Drawing Files\CADD_Sheets\Structural\Wolf Road_SHT13_SuperstructureDetails.dgn
 1/28/2022 3:17:26 PM

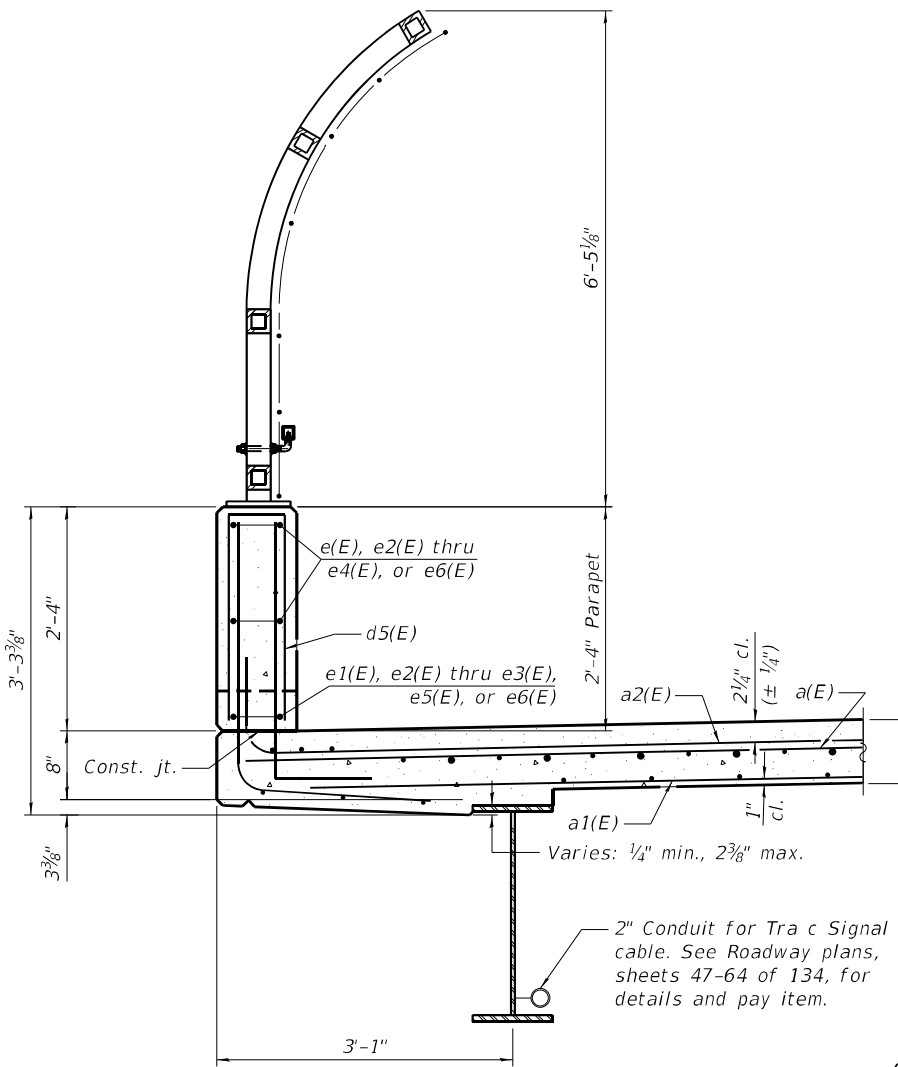

SECTION THRU PARAPET

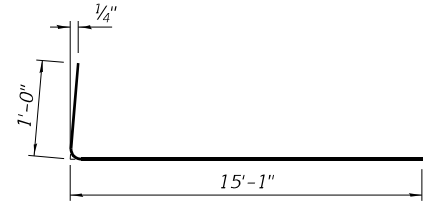
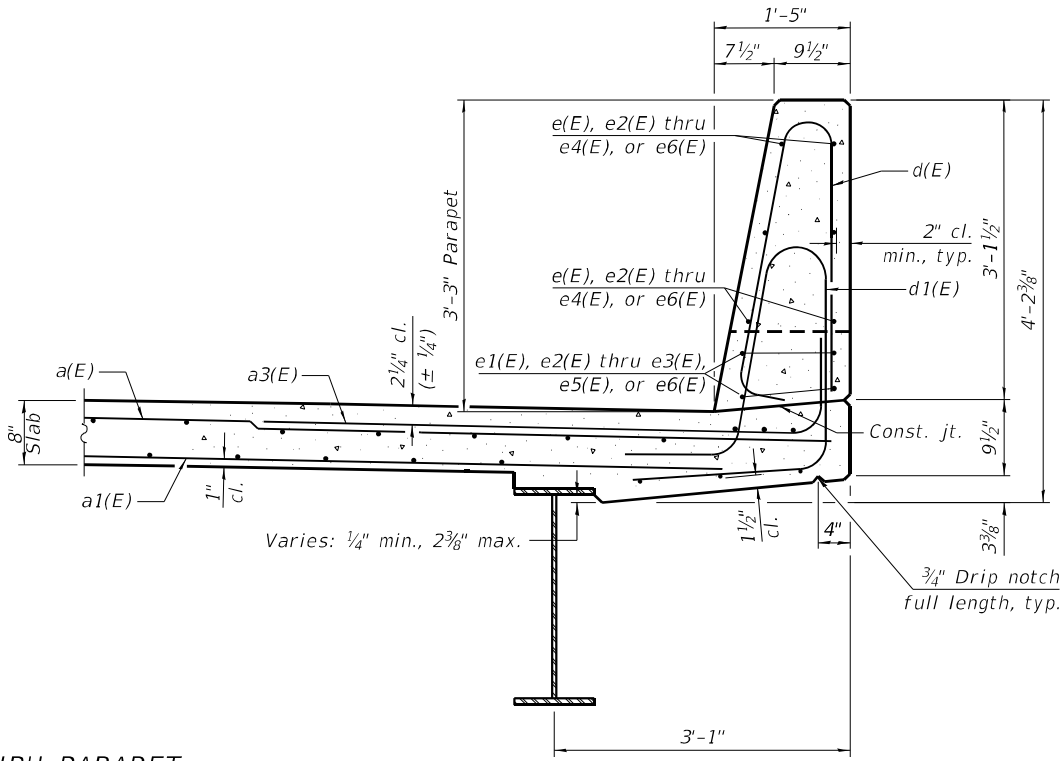

BAR a2(E)

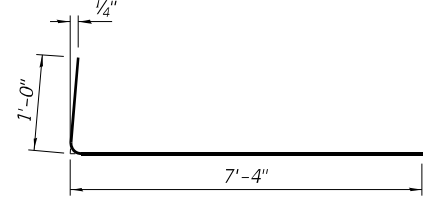

BAR a3(E)

**SUPERSTRUCTURE
 BILL OF MATERIAL**

Bar	No.	Size	Length	Shape
a(E)	439	#5	45'-4"	—
a1(E)	259	#5	45'-4"	—
a2(E)	431	#6	16'-1"	—
a3(E)	431	#6	8'-4"	—
b(E)	400	#5	30'-10"	—
b1(E)	129	#6	38'-8"	—
b2(E)	432	#5	27'-8"	—
d(E)	714	#5	6'-5"	—
d1(E)	334	#5	8'-6"	—
d2(E)	334	#5	8'-4"	—
d3(E)	334	#5	3'-6"	—
d4(E)	334	#5	3'-7"	—
d5(E)	380	#5	4'-6"	—
e(E)	64	#4	17'-2"	—
e1(E)	20	#4	34'-7"	—
e2(E)	52	#4	8'-7"	—
e3(E)	52	#4	6'-8"	—
e4(E)	96	#4	16'-9"	—
e5(E)	40	#4	26'-8"	—
e6(E)	52	#4	8'-8"	—
m10(E)	8	#6	45'-4"	—
m11(E)	48	#6	6'-3"	—
m12(E)	16	#6	2'-9"	—
m13(E)	4	#4	45'-4"	—
s10(E)	100	#5	6'-2"	—
s11(E)	100	#5	8'-0"	—
u10(E)	100	#4	3'-6"	—
v100(E)	94	#5	3'-1"	—
Reinforcement Bars, Epoxy Coated		Lbs.	98,140	
Concrete Superstructure		Cu. Yds.	361.6	
Bridge Deck Grooving		Sq. Yd.	741	
Protective Coat		Sq. Yd.	1,398	

Bars indicated thus 1 x 2-#4 etc. indicates 1 line of bars with 2 lengths per line.

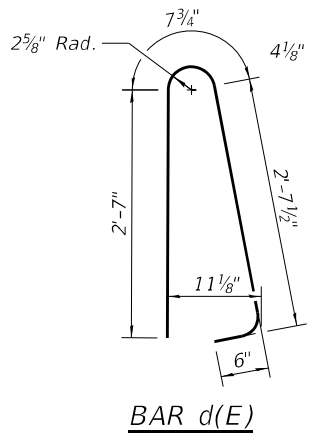

BAR d(E)

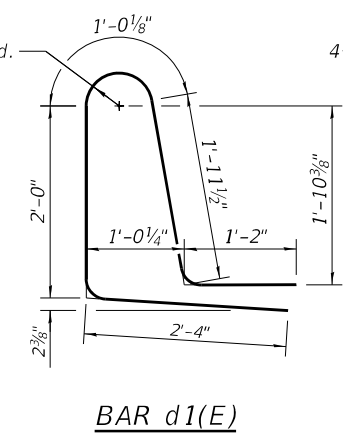

BAR d1(E)

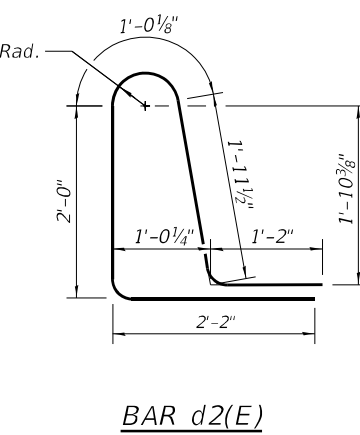

BAR d2(E)

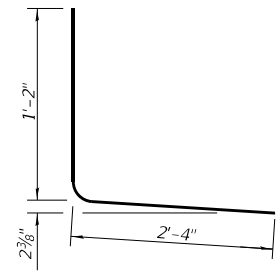

BAR d3(E)

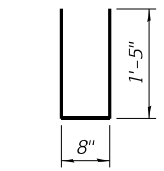

BAR u10(E)

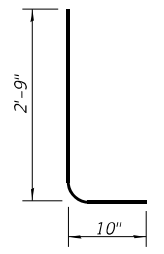

BAR d4(E)

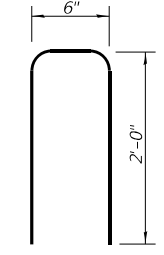

BAR d5(E)

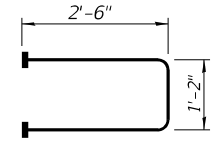

**BAR s10(E)
 (Headed)**

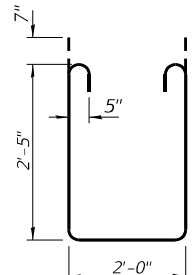

BAR s11(E)



USER NAME =	rvandermus	DESIGNED	KJA	REVISED	-
CHECKED	MG	REVISIONS			
PLOT SCALE =	20' = 1"	DRAWN	MG	REVISED	-
PLOT DATE =	1/28/2022	CHECKED	KJA	REVISED	-

**STATE OF ILLINOIS
 DEPARTMENT OF TRANSPORTATION**

**SUPERSTRUCTURE DETAILS
 STRUCTURE NO. 099-0192**

SHEET 13 OF 38 SHEETS

F.A.U. RTE.	SECTION	COUNTY	TOTAL SHEETS	SHEET NO.
2688	2020-250-BY	WILL	133	75
			CONTRACT NO. 62N20	
ILLINOIS				

MODEL: Default
 FILE NAME: p:\p\primera-pw\ben\key.com\primera-pw\01\Documents\01\Projects\2020\20200425\01_WO_1-3 - Wolf Road over I-80\Drawings\Current Drawing Files\CADD_Sheets\Structural\Wolf Road_SHT 14_DiaphragmDetails.dgn
 1/28/2022 3:17:27 PM

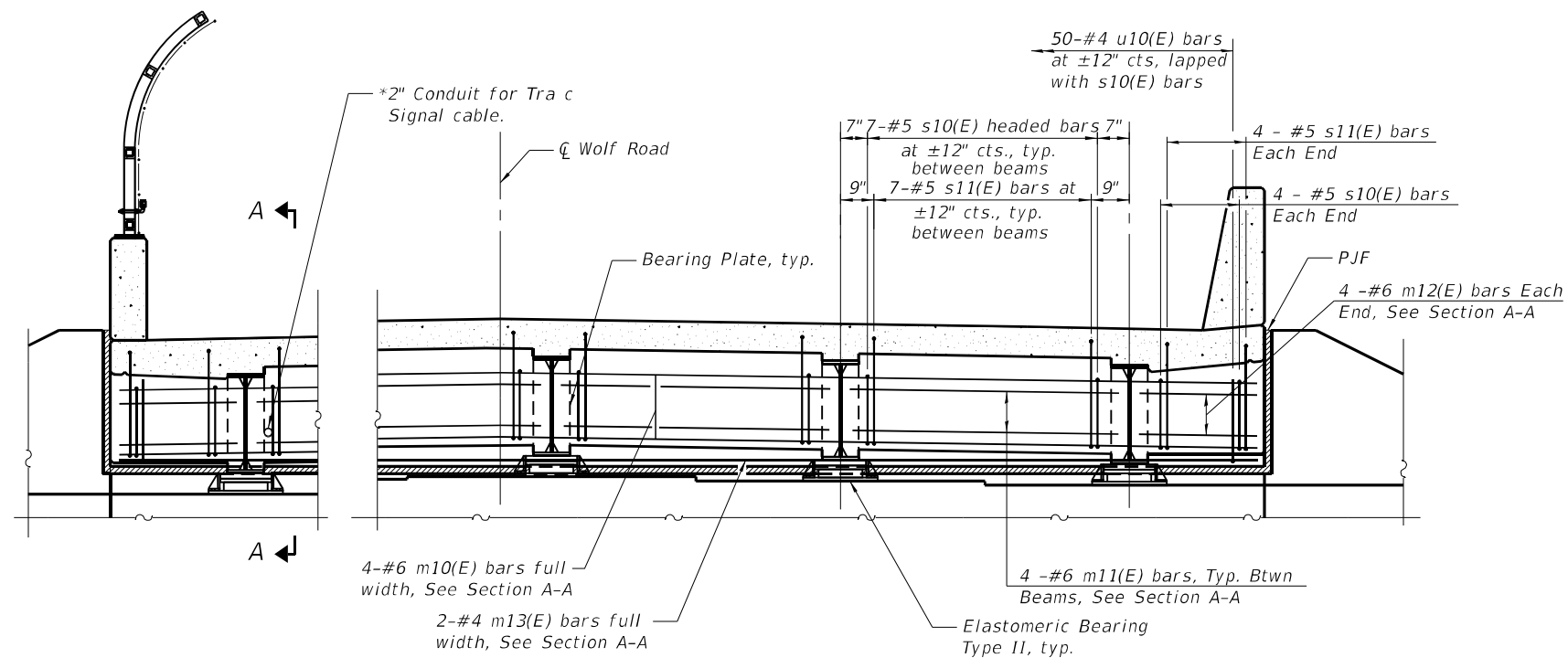

DIAPHRAGM AT ABUTMENT

* See Roadway plans, sheets 47-64 of 134, for details and pay item.

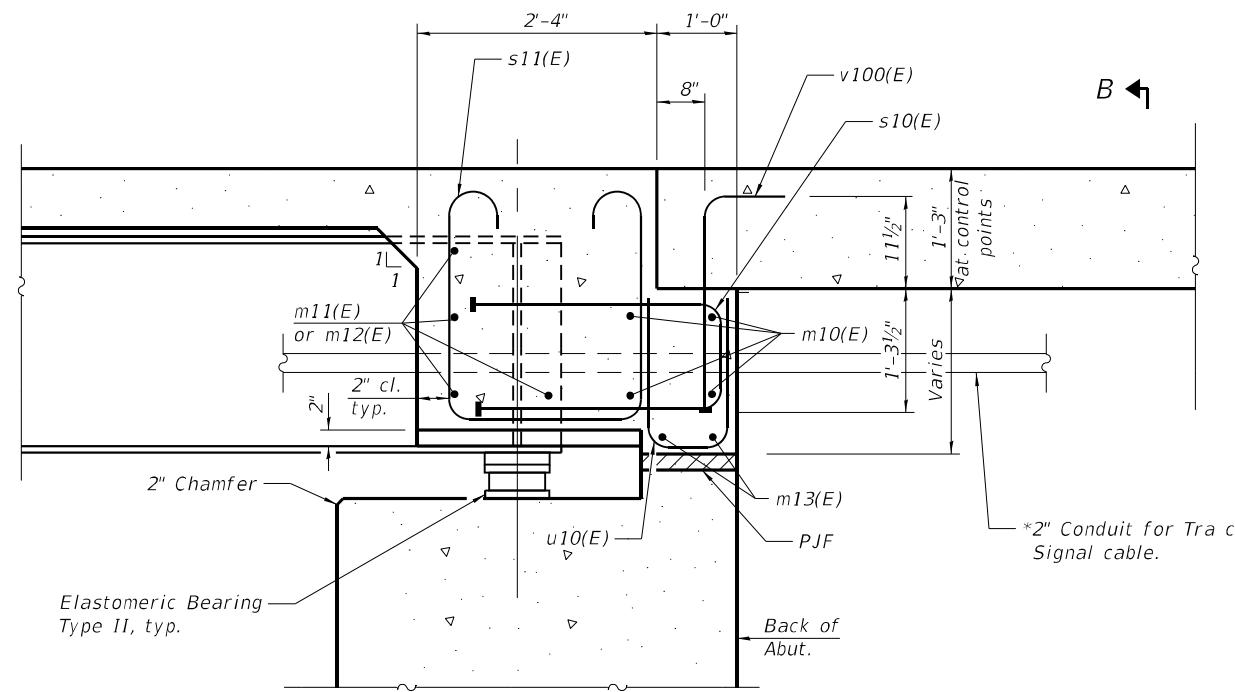

SECTION A-A

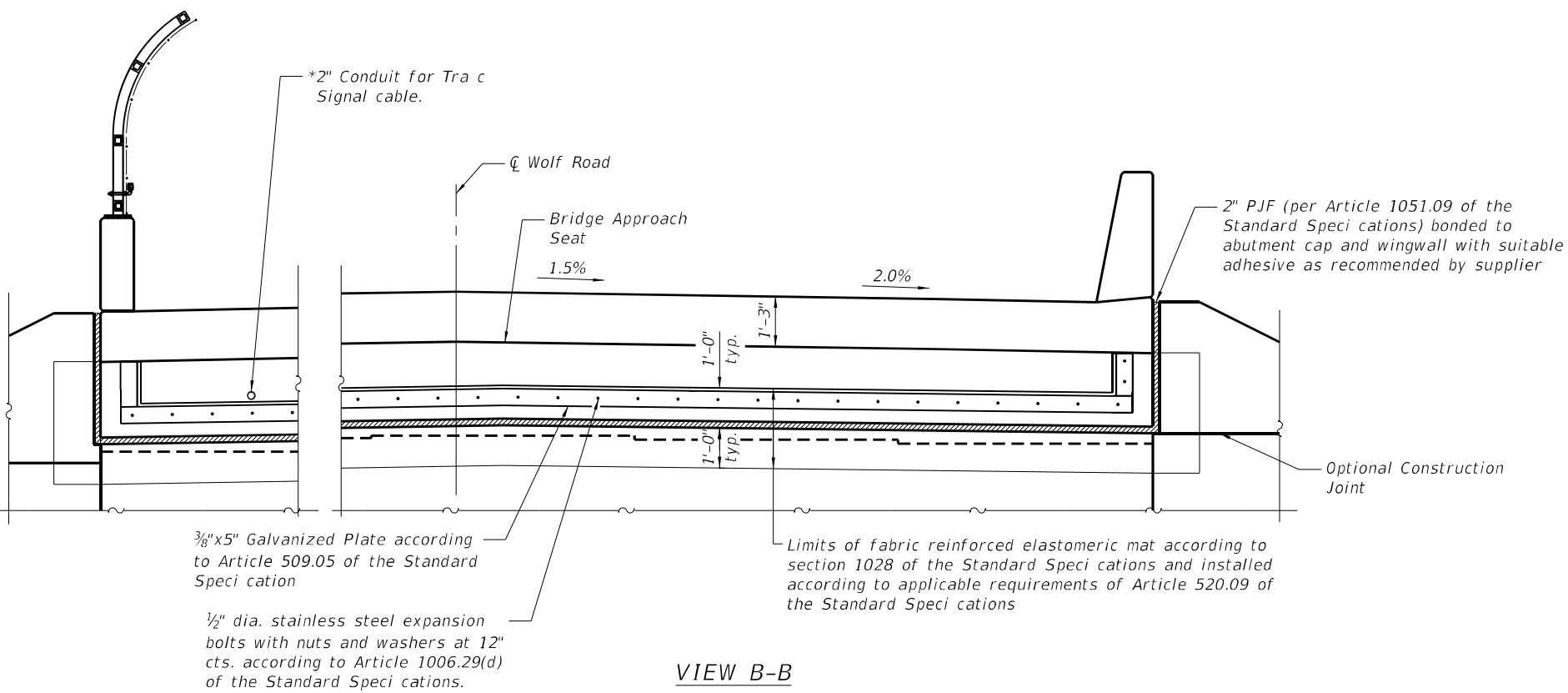

VIEW B-B

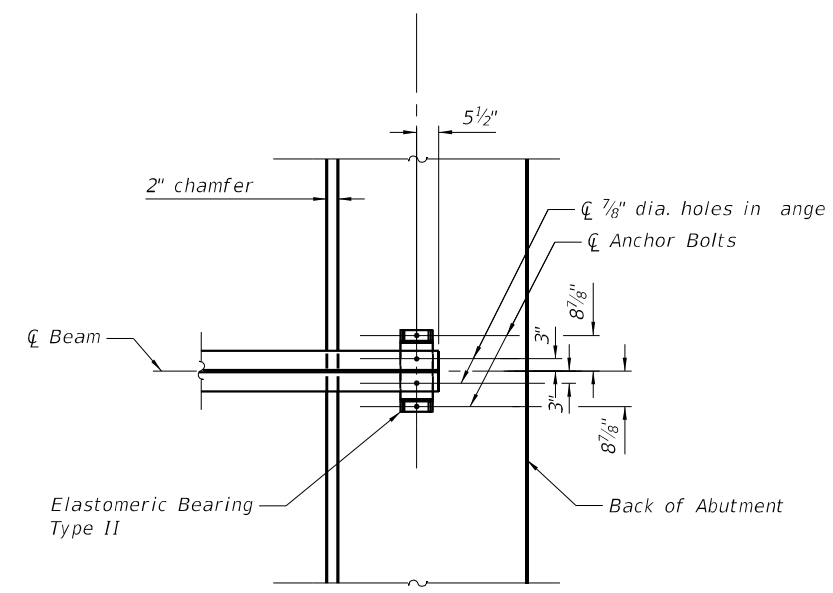

PLAN AT ABUTMENT

(Showing bottom angle of beam)

Notes:
 See sheet 13 of 38 for superstructure details and Bill of Material.
 Cost of fabric reinforced elastomeric mat, galvanized plate, preformed joint filler, stainless steel expansion bolts with nuts and washers and installation are included in the cost of Concrete Superstructure.



USER NAME =	rvandermus	DESIGNED	KJA	REVISED	-
CHECKED	MG	REVISIONS			
PLOT SCALE =	4.0000' / in.	DRAWN	MG	REVISIONS	
PLOT DATE =	1/28/2022	CHECKED	KJA	REVISIONS	

**STATE OF ILLINOIS
 DEPARTMENT OF TRANSPORTATION**

**DIAPHRAGM DETAILS
 STRUCTURE NO. 099-0192**

SHEET 14 OF 38 SHEETS

F.A.U. RTE.	SECTION	COUNTY	TOTAL SHEETS	SHEET NO.
2688	2020-250-BY	WILL	133	76
			CONTRACT NO. 62N20	
ILLINOIS				

MODEL: Default
 FILE NAME: p:\projects\primera\pw\01\Documents\01\Projects\2020\20200425_01_WO_1-3 - Wolf Road over I-80\Drawings\Current Drawing Files\CADD_Sheets\Structural\Wolf Road_SHT15_BridgeFenceRailingsParapetMounted.dgn
 PROJECTS: 2020\20200425_01 - IDOT Phase II Various Design\2020\20200425_01_WO_1-3 - Wolf Road over I-80\Drawings\Current Drawing Files\CADD_Sheets\Structural\Wolf Road_SHT15_BridgeFenceRailingsParapetMounted.dgn
 1/28/2022 3:17:28 PM

All steel rail elements shall be galvanized according to Article 509.05 of the Standard Specifications.

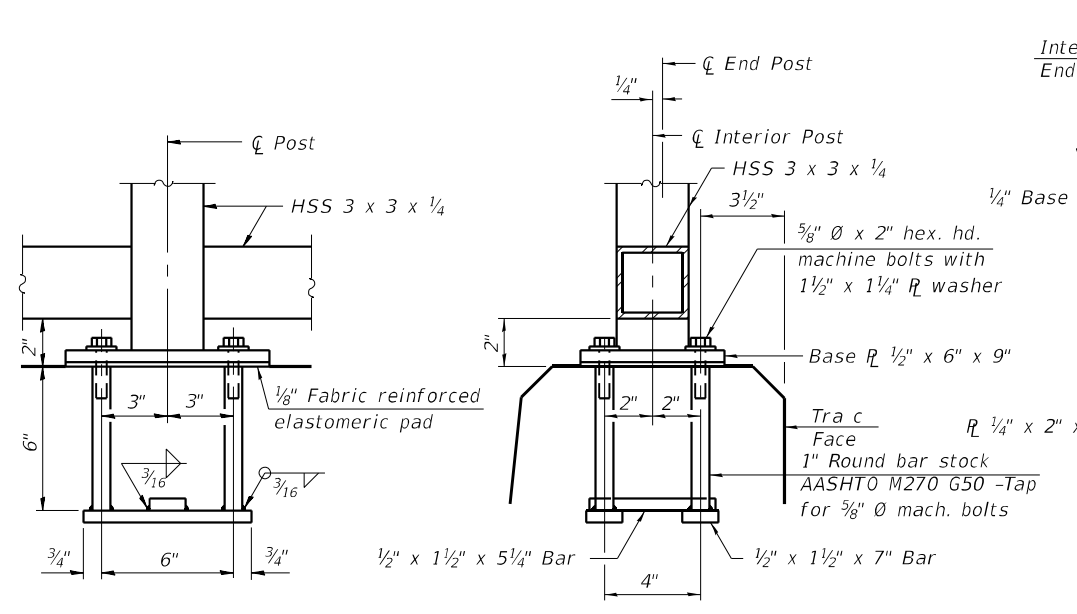
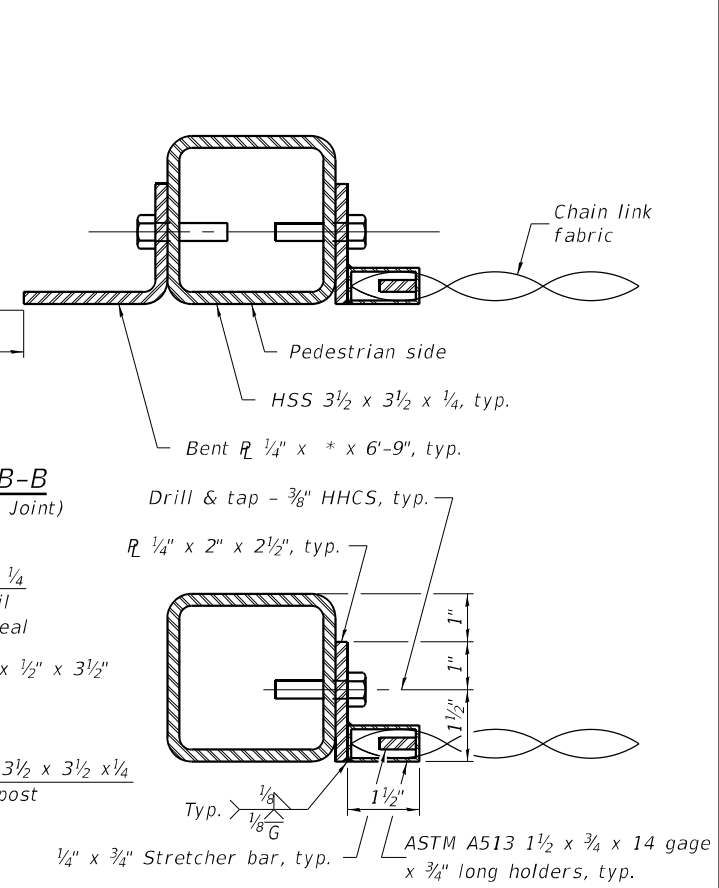
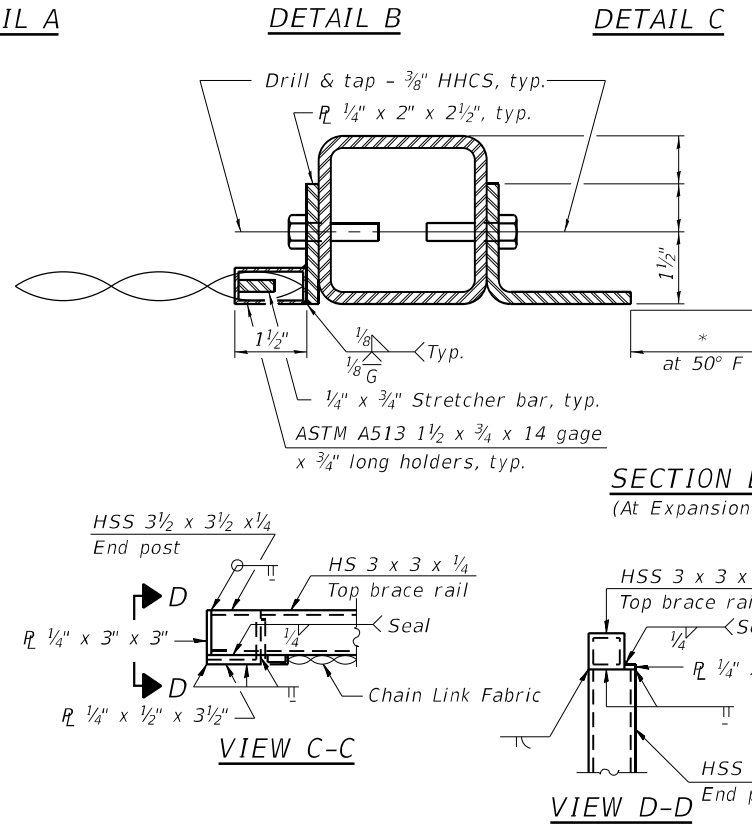
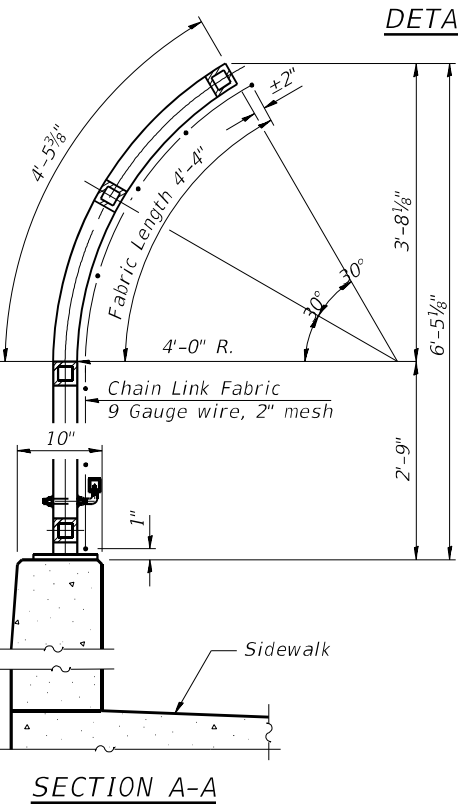
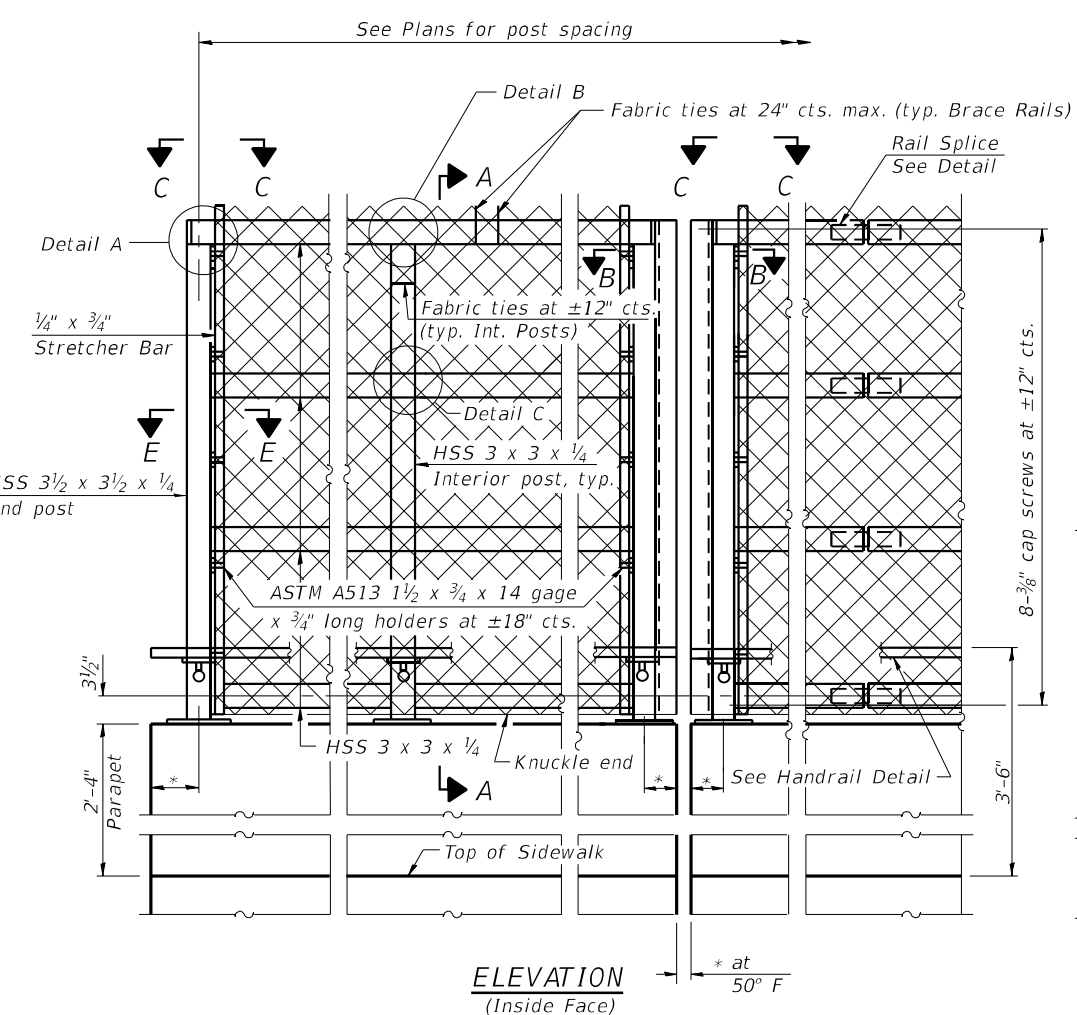

ANCHOR BOLT DETAILS
 In lieu of the cast-in-place anchor device shown, the Contractor has the option of drilling and setting 5/8" Ø anchor rods according to Article 509.06 of the Standard Specifications. Embedment shall be according to the manufacturer's specifications.

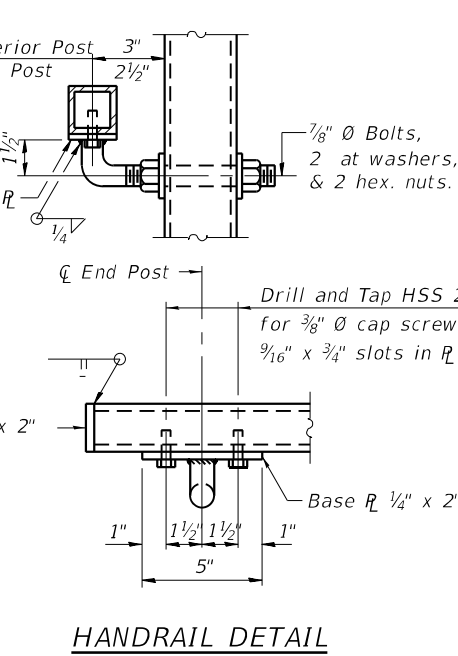

HANDRAIL DETAIL

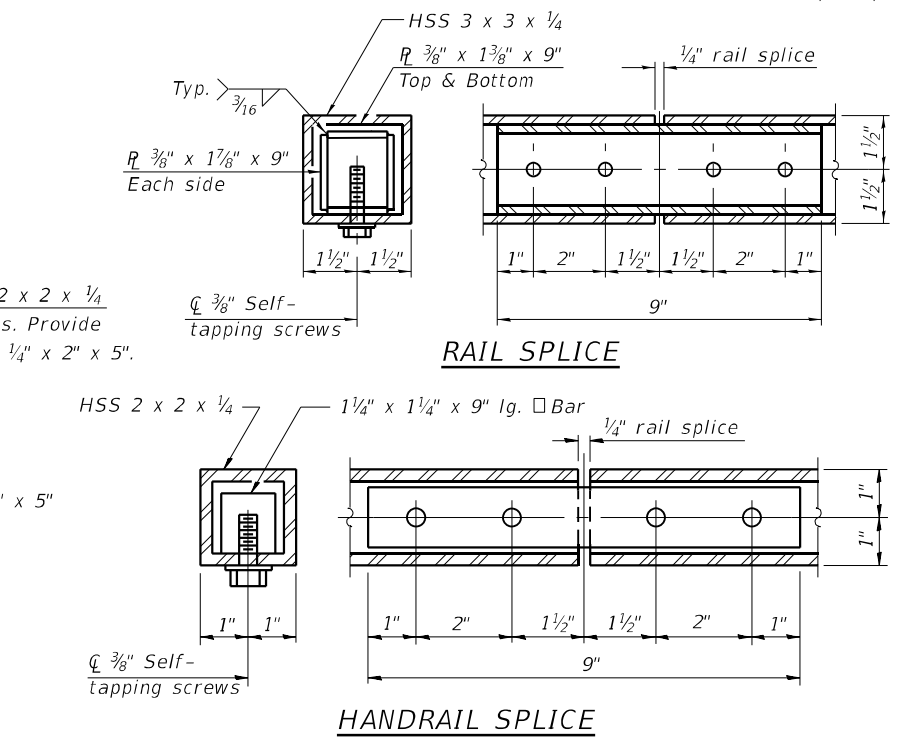

RAIL SPLICE

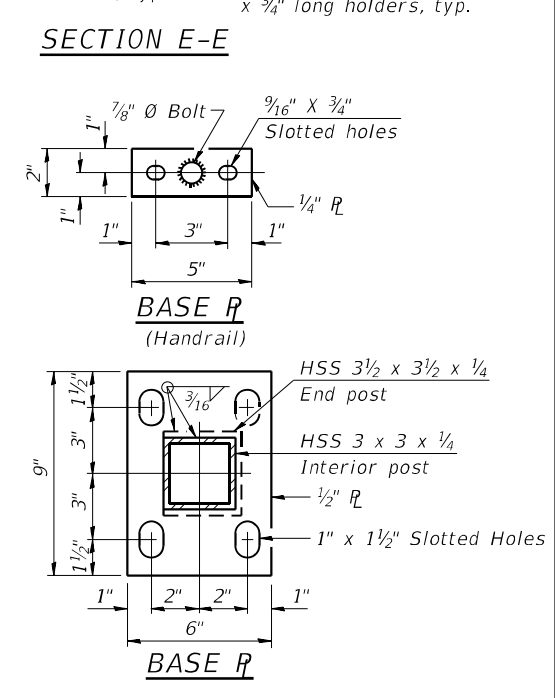

BASE R (Handrail)

BILL OF MATERIAL

Item	Unit	Quantity
Bridge Fence Railing	Foot	278

R-32 1-14-2019 *Variable - See Plans (10'-0" Maximum Post Spacing)

USER NAME = rvandermus	DESIGNED = KJA	REVISED = -
PLOT SCALE = 2.0000' / in.	CHECKED = MG/ZM	REVISED = -
PLOT DATE = 1/28/2022	DRAWN = KC	REVISED = -
	CHECKED = KJA	REVISED = -

**STATE OF ILLINOIS
 DEPARTMENT OF TRANSPORTATION**

**BRIDGE FENCE RAILING, PARAPET MOUNTED
 STRUCTURE NO. 099-0192**

F.A.U. RTE. 2688	SECTION 2020-250-BY	COUNTY WILL	TOTAL SHEETS 133	SHEET NO. 77
			CONTRACT NO. 62N20	

SHEET 15 OF 38 SHEETS

ILLINOIS

MODEL: Default
 FILE NAME: p:\projects\primera\p\p\1\Documents\01 Projects\2020\20200425.00 - IDOT Phase II Various Design\20200425.01_WO 1-3 - Wolf Road over I-80\Drawings\Current Drawing Files\CADD Sheets\Structural\Wolf Road_SHT16_ParapetRailing.dgn
 1/28/2022 3:17:30 PM

All steel rail elements shall be galvanized according to Article 509.05 of the Standard Specifications.

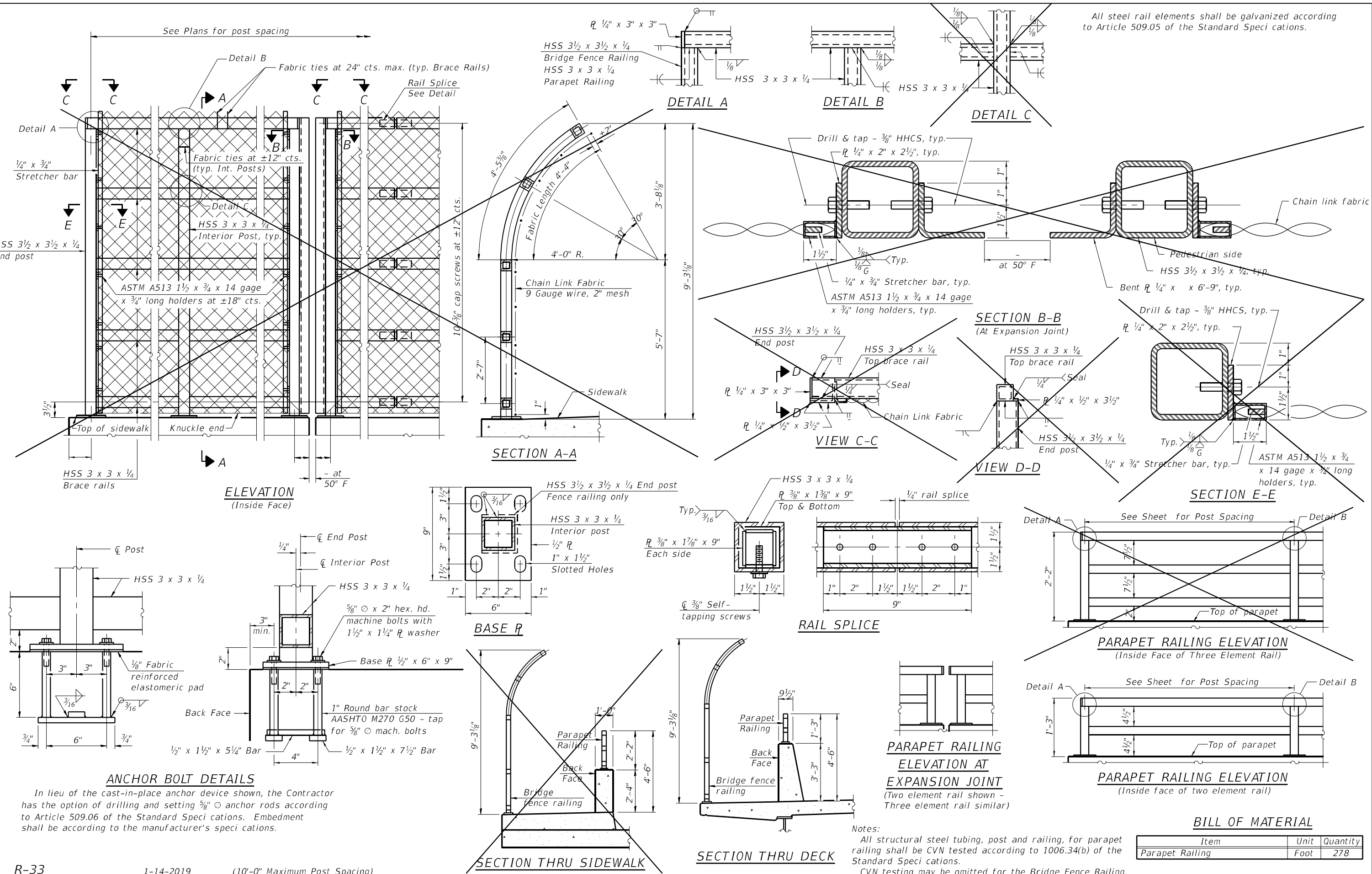

R-33 1-14-2019 (10'-0" Maximum Post Spacing)

ANCHOR BOLT DETAILS
 In lieu of the cast-in-place anchor device shown, the Contractor has the option of drilling and setting 3/8" Ø anchor rods according to Article 509.06 of the Standard Specifications. Embedment shall be according to the manufacturer's specifications.

Notes:
 All structural steel tubing, post and railing, for parapet railing shall be CVN tested according to 1006.34(b) of the Standard Specifications. CVN testing may be omitted for the Bridge Fence Railing.

BILL OF MATERIAL		
Item	Unit	Quantity
Parapet Railing	Foot	278



USER NAME =	rvandermus	DESIGNED	KJA	REVISED	-
CHECKED	MGZM	CHECKED	MGZM	REVISED	-
PLOT SCALE =	2.0000" / in.	DRAWN	KC	REVISED	-
PLOT DATE =	1/28/2022	CHECKED	KJA	REVISED	-

**STATE OF ILLINOIS
 DEPARTMENT OF TRANSPORTATION**

**PARAPET RAILING
 STRUCTURE NO. 099-0192**

SHEET 16 OF 38 SHEETS

F.A.U. RTE.	SECTION	COUNTY	TOTAL SHEETS	SHEET NO.
2688	2020-250-BY	WILL	133	78
			CONTRACT NO. 62N20	
			ILLINOIS	

MODEL: Default
 FILE NAME: p:\w\primera-pw\ben\key.com\primera-pw\01\Documents\01\Projects\2020\200425\00 - IDOT Phase II Various Design\20200425_01_WO_1-3 - Wolf Road over I-80\Drawings\Current Drawing Files\CADD_Sheets\Structural\Wolf Road_SHT18_ApproachSlabDetails.dgn
 100 S. WABLER DRIVE SUITE 700, CHICAGO IL 60606 - P.312-405-8919 F.312-406-4145
 1/28/2022 3:17:35 PM

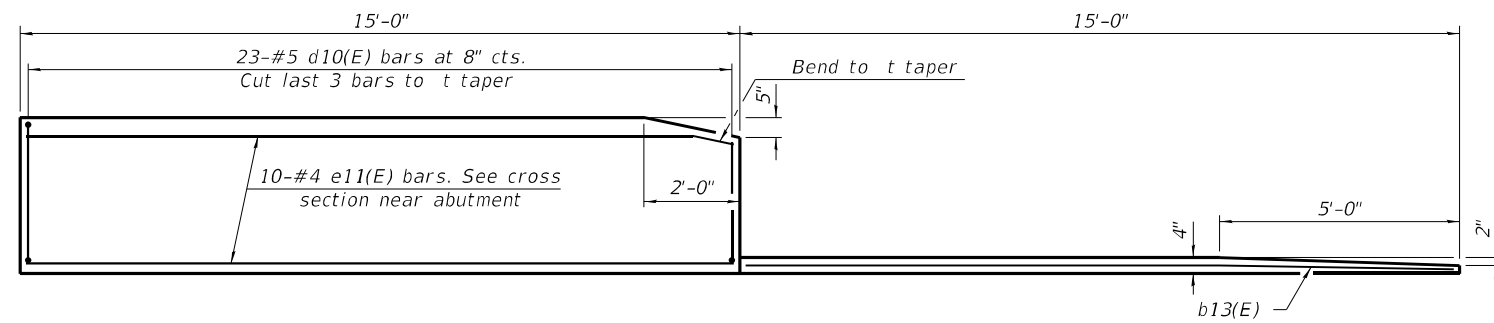

INSIDE ELEVATION OF EAST 39" PARAPET AND CURB

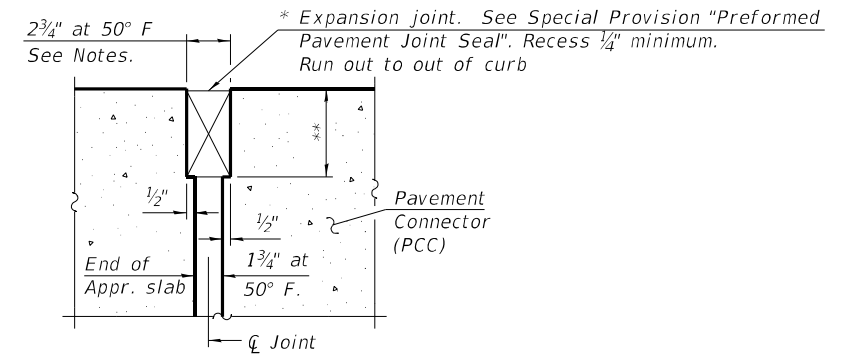

DETAIL A

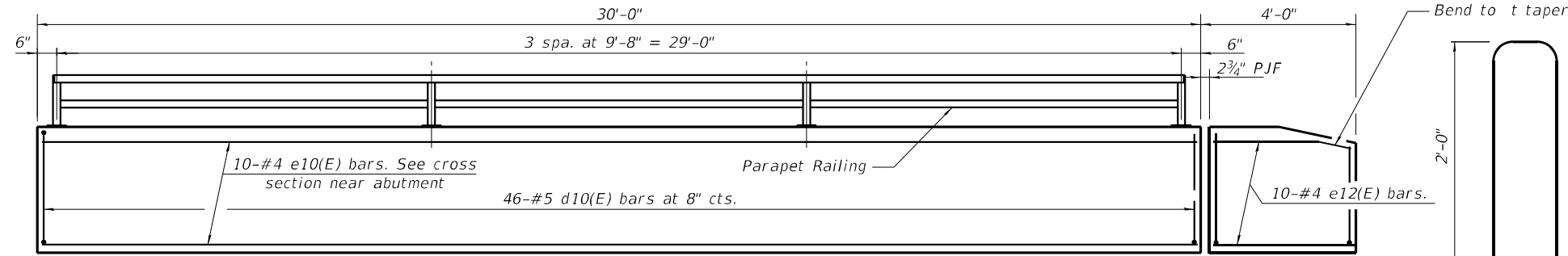

INSIDE ELEVATION OF WEST 39" PARAPET

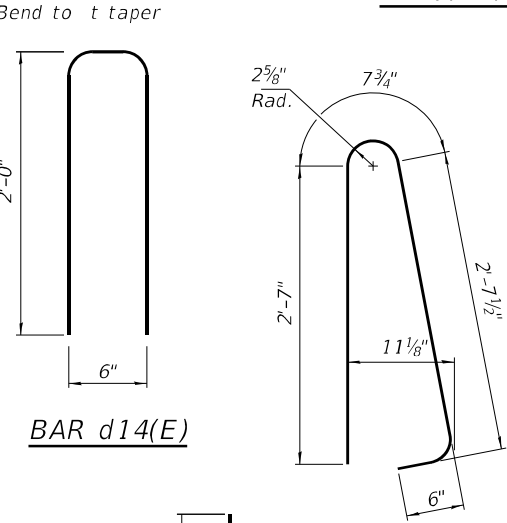

BAR d14(E)

BAR d10(E)

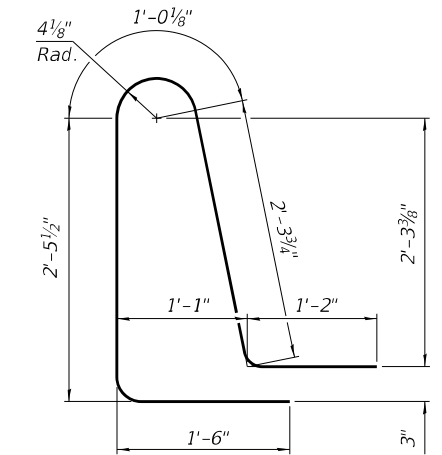

BAR d11(E)

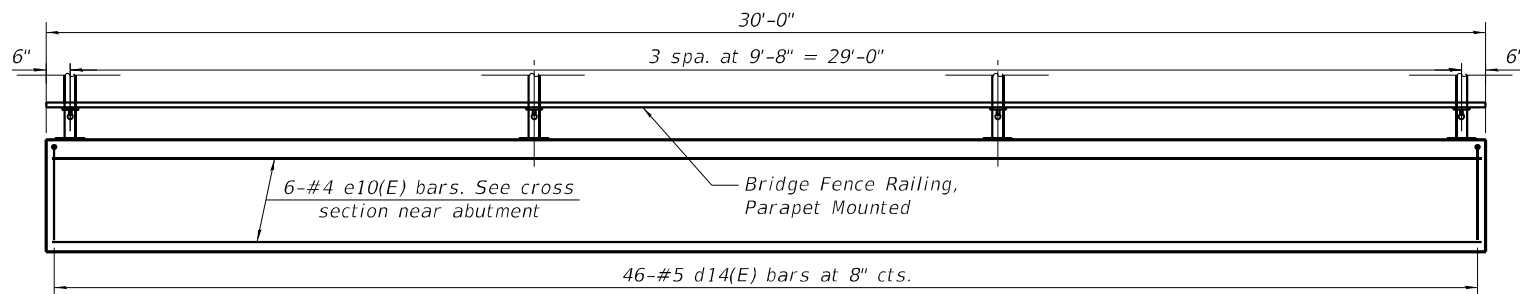

INSIDE ELEVATION OF WEST 28" PARAPET

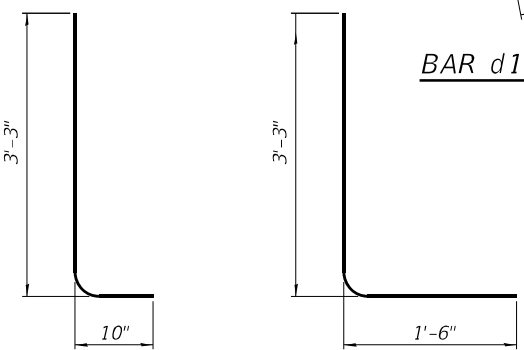

BAR d12(E)

BAR d13(E)

**TWO APPROACHES
BILL OF MATERIAL**

Bar	No.	Size	Length	Shape
a10(E)	92	#5	44'-11"	┌───┐
a11(E)	122	#8	45'-4"	┌───┐
a12(E)	138	#5	7'-4"	┌───┐
b10(E)	136	#5	29'-8"	┌───┐
b11(E)	224	#9	29'-8"	┌───┐
b12(E)	8	#5	14'-8"	┌───┐
b13(E)	2	#4	14'-8"	┌───┐
d10(E)	152	#5	6'-5"	┌──┐
d11(E)	152	#5	8'-6"	┌──┐
d12(E)	92	#5	4'-1"	┌──┐
d13(E)	92	#5	4'-9"	┌──┐
d14(E)	92	#5	4'-6"	┌──┐
e10(E)	32	#4	29'-8"	┌───┐
e11(E)	20	#4	14'-8"	┌───┐
e12(E)	20	#4	3'-8"	┌───┐
t10(E)	92	#4	9'-8"	┌───┐
w10(E)	80	#5	44'-5"	┌───┐
Concrete Superstructure		Cu. Yd.	17.4	
Concrete Superstructure (Approach Slab)		Cu. Yd.	125.8	
Concrete Structures		Cu. Yd.	22.1	
Reinforcement Bars, Epoxy Coated		Pound	55,910	
Bridge Deck Grooving		Sq. Yd.	200	
Protective Coat		Sq. Yd.	373	

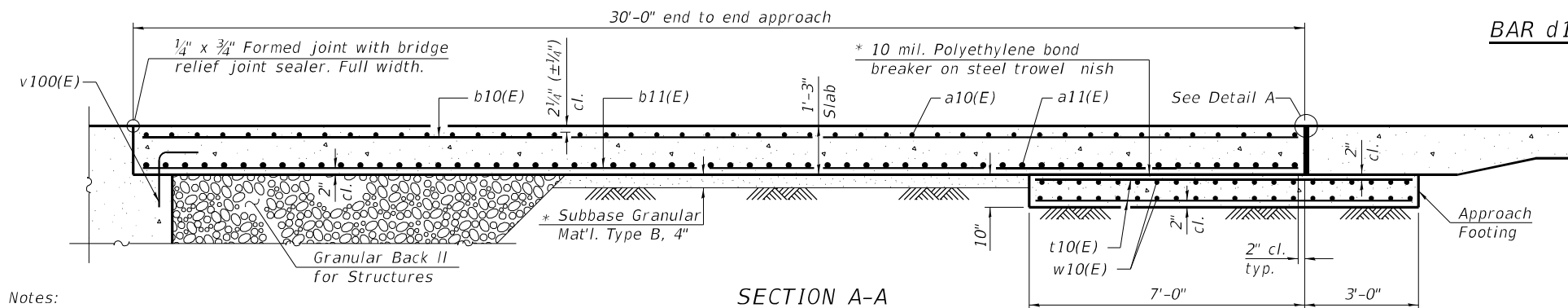

SECTION A-A

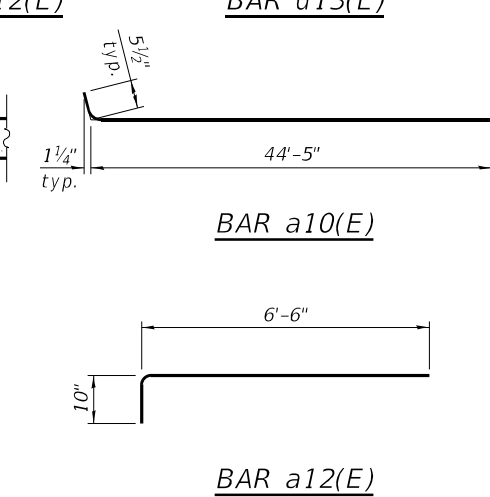

BAR a10(E)

BAR a12(E)

Notes:
 The joint opening shall be adjusted for temperature per Article 520.04 of the Standard Specifications. However, since this detail is for jointless structures, the length of bridge used to calculate the adjustment shall be equal to half the total bridge length plus the length of the bridge approach slab.
 Parapet concrete shall be paid for as Concrete Superstructure.
 Approach slab shall be paid for as Concrete Superstructure (Approach Slab).
 Approach footing concrete shall be paid for as Concrete Structures.
 The approach footing maximum applied service bearing pressure (Qmax) = 2.0 ksf.
 Cost of excavation for approach footing included with Concrete Structures.
 For Granular Back II for Structures and drainage treatment details, see sheet 26 of 38.

* Cost included with Concrete Superstructure (Approach Slab).

** Per manufacturer recommendations

(Sheet 2 of 2)



USER NAME =	rvandermus	DESIGNED	KJA	REVISED	-
CHECKED	MG/ZM	REVISION		REVISED	-
PLOT SCALE =	2.0000" / in.	DRAWN	KC	REVISED	-
PLOT DATE =	1/28/2022	CHECKED	KJA	REVISED	-

**STATE OF ILLINOIS
DEPARTMENT OF TRANSPORTATION**

**BRIDGE APPROACH SLAB DETAILS
STRUCTURE NO. 099-0192**

SHEET 18 OF 38 SHEETS

F.A.U. RTE.	SECTION	COUNTY	TOTAL SHEETS	SHEET NO.
2688	2020-250-BY	WILL	133	80
			CONTRACT NO. 62N20	
ILLINOIS				

MODEL: Default
 FILE NAME: p:\projects\primera\pw\01\Documents\01\Projects\2020\20200425\01_WO_1-3 - Wolf Road over I-80\Drawings\Current Drawing Files\CADD_Sheets\Structural\Wolf Road_SHT19_FramingPlan.dgn
 1/28/2022 3:17:37 PM

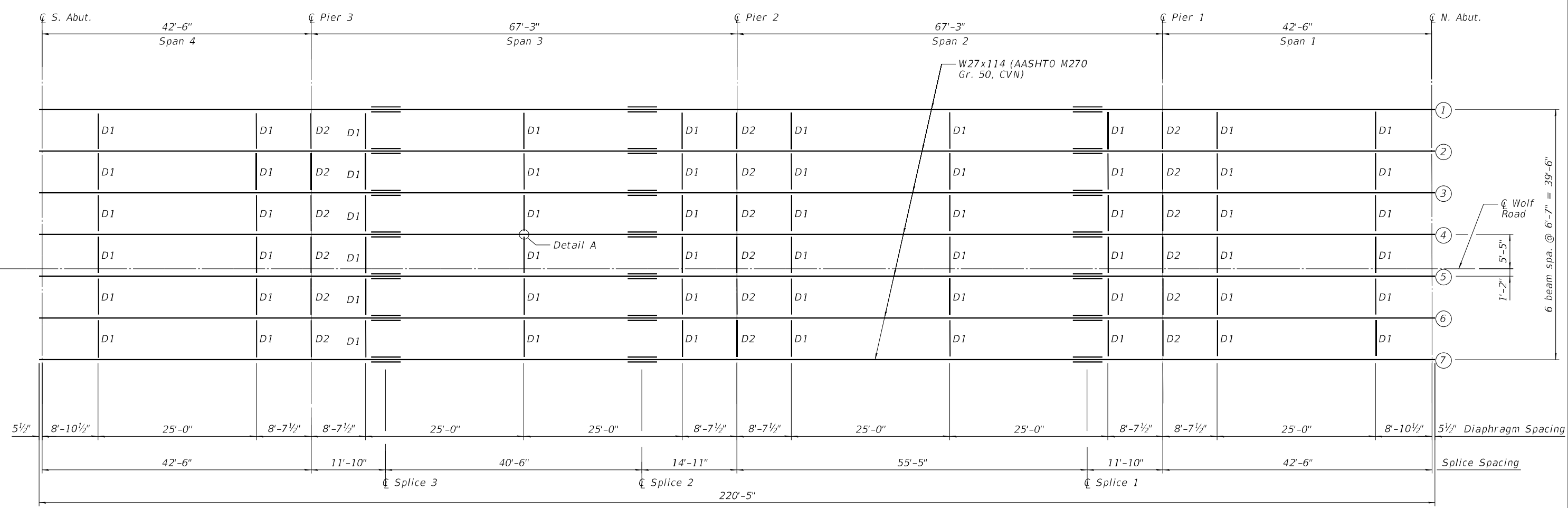

FRAMING PLAN

"CVN" denotes Charpy-V-Notch impact energy requirements, zone 2.

Note:
 All cross frames or diaphragms shall be installed as steel is erected and secured with erection pins and bolts except as otherwise noted.
 Individual cross frames or diaphragms at supports may be temporarily disconnected to install bearing anchor rods.

TOP OF BEAM ELEVATIONS							
	Beam 1	Beam 2	Beam 3	Beam 4	Beam 5	Beam 6	Beam 7
☐ Brg. S. Abut.	740.58	740.71	740.84	740.94	741.00	740.90	740.79
☐ Ex. Pier 3	740.80	740.93	741.06	741.16	741.23	741.13	741.02
☐ Splice 3	740.87	740.99	741.13	741.23	741.29	741.19	741.08
☐ Splice 2	740.98	741.10	741.23	741.33	741.40	741.30	741.19
☐ Ex. Pier 2	740.95	741.07	741.21	741.30	741.37	741.27	741.16
☐ Splice 1	740.84	740.97	741.10	741.20	741.26	741.16	741.05
☐ Ex. Pier 1	740.77	740.90	741.03	741.13	741.19	741.09	740.98
☐ Brg. N. Abut.	740.52	740.65	740.78	740.88	740.95	740.85	740.74



USER NAME =	rvaidermus	DESIGNED	KJA	REVISED	-
CHECKED	MG	REVISED	-		
PLOT SCALE =	16.0000' / in.	DRAWN	MG	REVISED	-
PLOT DATE =	1/28/2022	CHECKED	KJA	REVISED	-

STATE OF ILLINOIS
 DEPARTMENT OF TRANSPORTATION

FRAMING PLAN
 STRUCTURE NO. 099-0192

SHEET 19 OF 38 SHEETS

F.A.U. RTE.	SECTION	COUNTY	TOTAL SHEETS	SHEET NO.
2688	2020-250-BY	WILL	133	81
			CONTRACT NO. 62N20	
ILLINOIS				

MODEL: Default
 FILE NAME: p:\p\primera-pw\ben\key.com\primera-pw\01\Documents\01\Projects\2020\20200425\00 - IDOT Phase II Various Design\20200425\01_WO_1-3 - Wolf Road over I-80\Drawings\Current Drawing Files\CADD_Sheets\Structural\Wolf Road_SHT20_GirderElevation&Details.dgn
 1/28/2022 3:17:39 PM

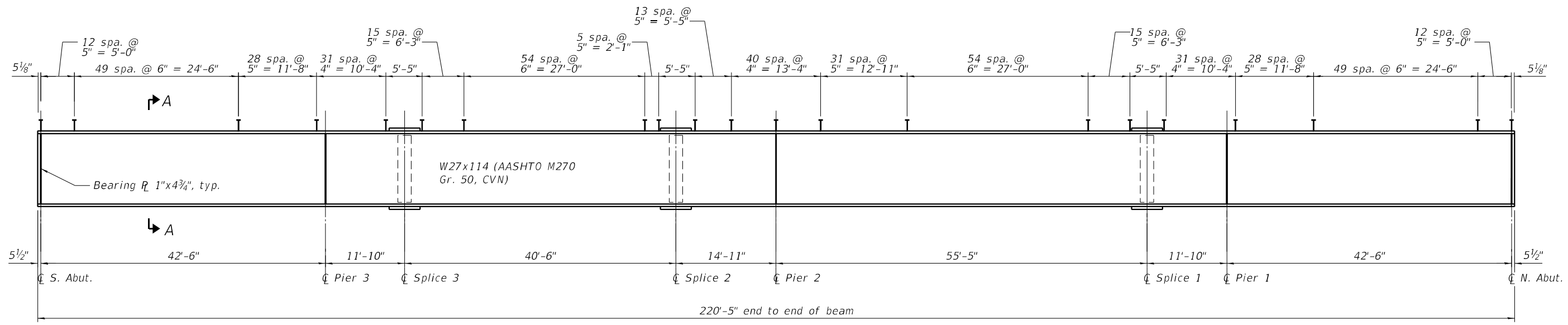

GIRDER ELEVATION

(Looking West)
 "CVN" denotes Charpy-V-Notch impact energy requirements, zone 2

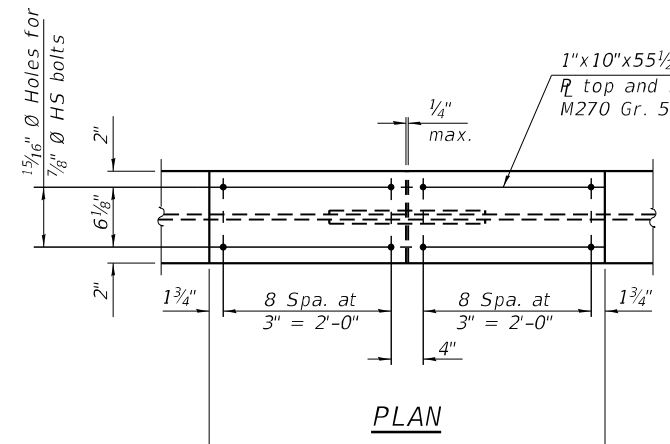

PLAN

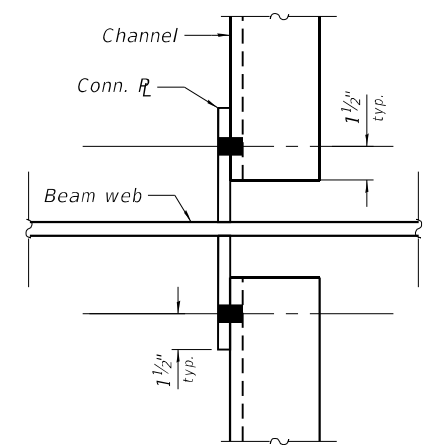

DETAIL A

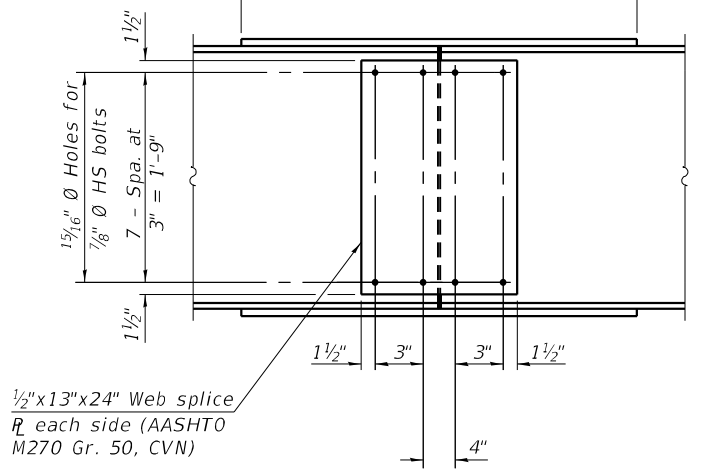

ELEVATION

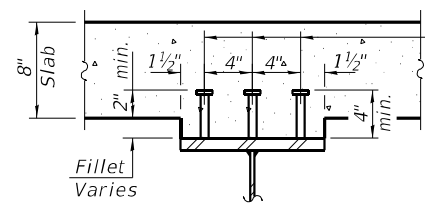

SECTION A-A

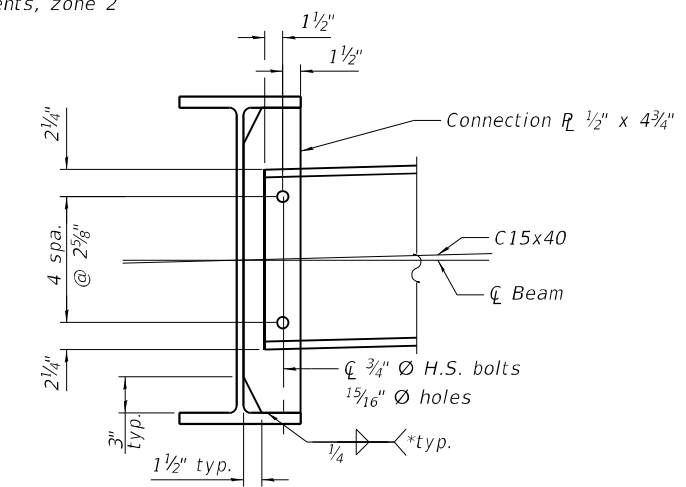

INTERIOR DIAPHRAGM D1

* Stop welds 1/4" (±1/8") from edges.

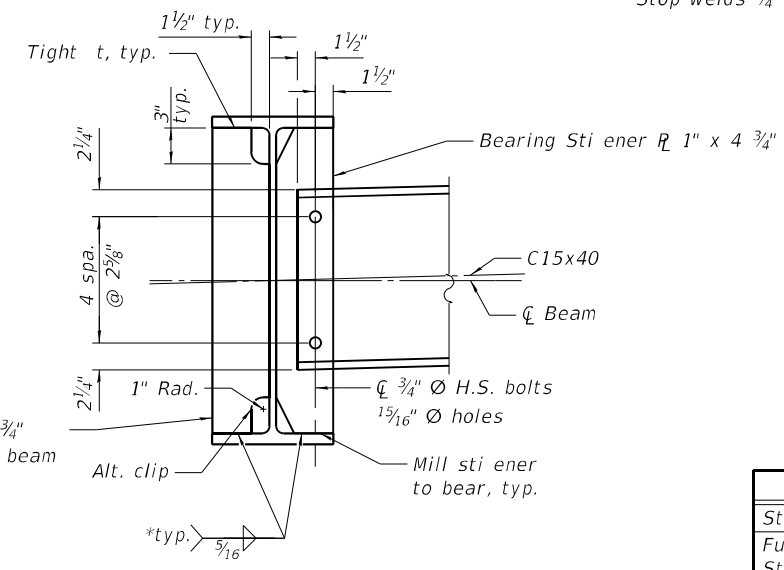

INTERIOR DIAPHRAGM D2

BILL OF MATERIAL

Item	Unit	Total
Stud Shear Connectors	Each	9,891
Furnishing & Erecting Structural Steel	L Sum	1



USER NAME =	rvandermus	DESIGNED	KJA KJA	REVISED	-
CHECKED	MG/ZMG	REVISED	-		
PLOT SCALE =	16.0000" / in.	DRAWN	KC MG	REVISED	-
PLOT DATE =	1/28/2022	CHECKED	KJA KJA	REVISED	-

**STATE OF ILLINOIS
 DEPARTMENT OF TRANSPORTATION**

**GIRDER ELEVATION AND DETAILS
 STRUCTURE NO. 099-0192**

SHEET 20 OF 38 SHEETS

F.A.U. RTE.	SECTION	COUNTY	TOTAL SHEETS	SHEET NO.
2688	2020-250-BY	WILL	133	82
			CONTRACT NO. 62N20	
ILLINOIS				

MODEL: Default
 FILE NAME: p:\w\primera-pw-bentley.com\primera-pw-01\Documents\01_Protects\Phase II Various Design\20200425_01_WO_1-3 - Wolf Road over I-80\Drawings\Current Drawing Files\CADD_Sheets\Structural\Wolf Road_SHT23_BearingDetails.dgn
 IDOT Phase II Various Design\20200425_01_WO_1-3 - Wolf Road over I-80\Drawings\Current Drawing Files\CADD_Sheets\Structural\Wolf Road_SHT23_BearingDetails.dgn
 100 S. WACKER DRIVE SUITE 700, CHICAGO IL 60606 - P.312-405-8900 F.312-406-4105
 1/28/2022 3:17:43 PM

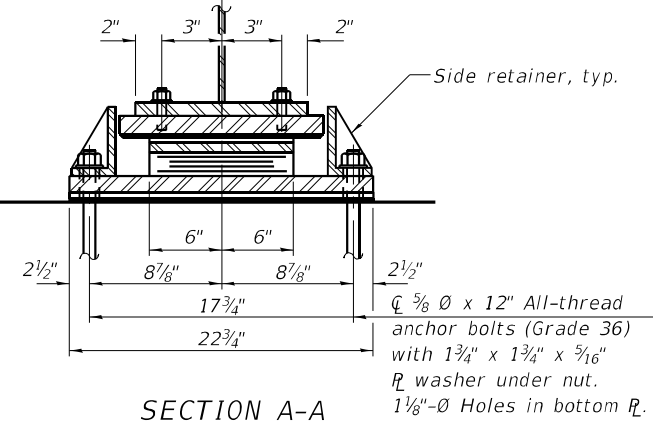
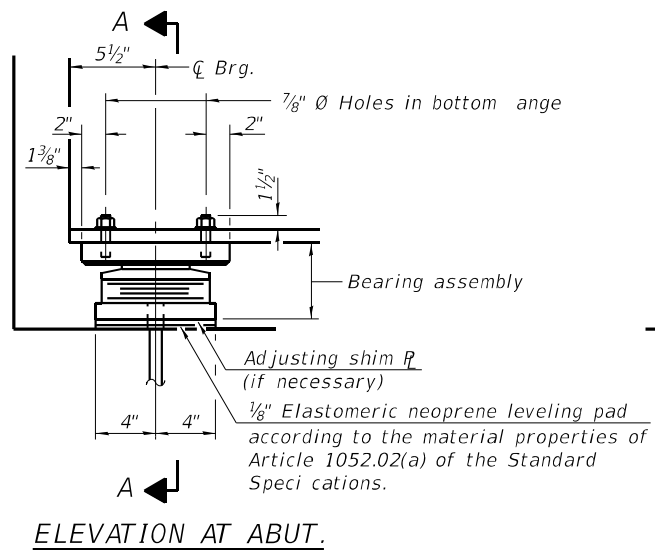

TYPE II ELASTOMERIC EXP. BRG.

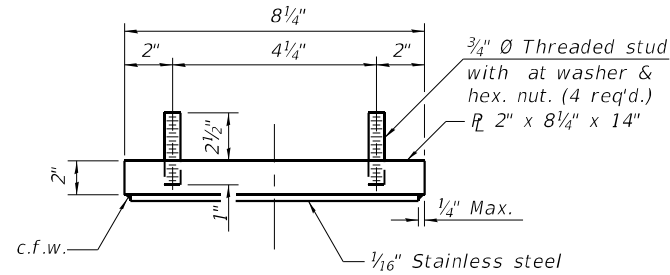

TOP BEARING ASSEMBLY

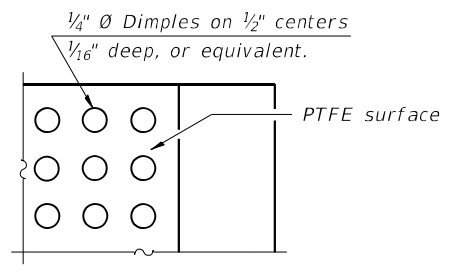

PLAN-PTFE SURFACE

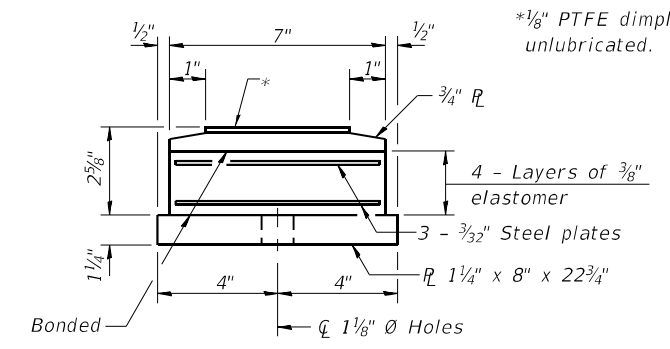

BOTTOM BEARING ASSEMBLY

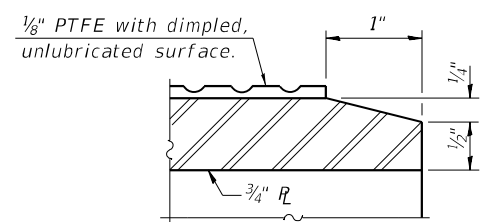

SECTION THRU PTFE

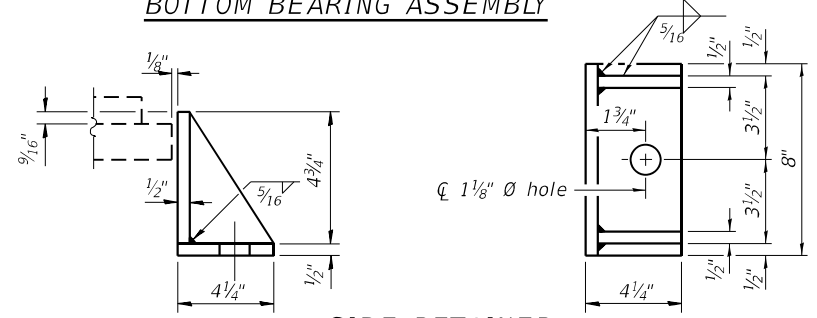

SIDE RETAINER

Equivalent rolled angle with stiffeners will be allowed in lieu of welded plates.

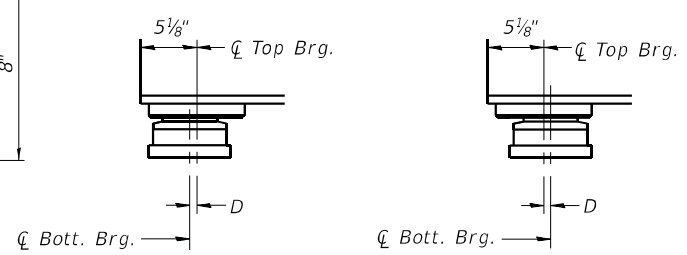

EXPANSION BEARING ORIENTATION

BELOW 50°F.
 ABOVE 50°F.
 D = 1/8" per each 100' of expansion for every 15° temp. change from the normal temp. of 50°F.
 The above diagrams are for informational purposes only to show the amount of expected offset "D" for the current temperature in the field.

Notes:
 Side retainers and leveling pad required for the elastomeric bearing assembly shall be included in the cost of Elastomeric Bearing Assembly, Type II.
 The 1/8" PTFE sheet shall be bonded directly to the top steel plate with a two-component, medium viscosity epoxy resin, conforming to the requirements of the Federal Specification MMM-A-134, Type I. The bond agent shall be applied on the full area of the contact surfaces.
 Bonding of 1/8" PTFE sheet during vulcanizing process will be permitted provided the process and method of adjusting assembly height is approved by the Engineer.
 Anchor bolts and side retainers at all supports shall be installed as each member is erected unless an equivalent temporary means of lateral restraint is used.
 Two 1/8" in adjusting shims shall be provided for each bearing in addition to all other plates or shims placed as shown on bearing details.
 The structural steel plates of the Bearing Assembly shall conform to the requirements of AASHTO M270 Grade 36.

BILL OF MATERIAL

Item	Unit	Total
Elastomeric Bearing Assembly Type II	Each	14
Anchor Bolts, 5/8"	Each	28



USER NAME = rvandermus	DESIGNED KJA	REVISED -
PLOT SCALE = 2.0000' / in.	CHECKED MGZM	REVISED -
PLOT DATE = 1/28/2022	DRAWN KC	REVISED -
	CHECKED KJA	REVISED -

**STATE OF ILLINOIS
 DEPARTMENT OF TRANSPORTATION**

**BEARING DETAILS II
 STRUCTURE NO. 099-0192**

SHEET 23 OF 38 SHEETS

F.A.U. RTE.	SECTION	COUNTY	TOTAL SHEETS	SHEET NO.
2688	2020-250-BY	WILL	133	85
			CONTRACT NO. 62N20	
ILLINOIS				

MODEL: Default
 FILE NAME: p:\projects\2020\20200425\01_WO_1-3 - Wolf Road over I-80\Drawings\Current Drawing Files\CADD_Sheets\Structural\Wolf Road_SHT24_NorthAbutmentPlan&Elevation.dgn
 IDOT Phase II Various Design\2020\20200425\01_WO_1-3 - Wolf Road over I-80\Drawings\Current Drawing Files\CADD_Sheets\Structural\Wolf Road_SHT24_NorthAbutmentPlan&Elevation.dgn
 1/28/2022 3:17:44 PM

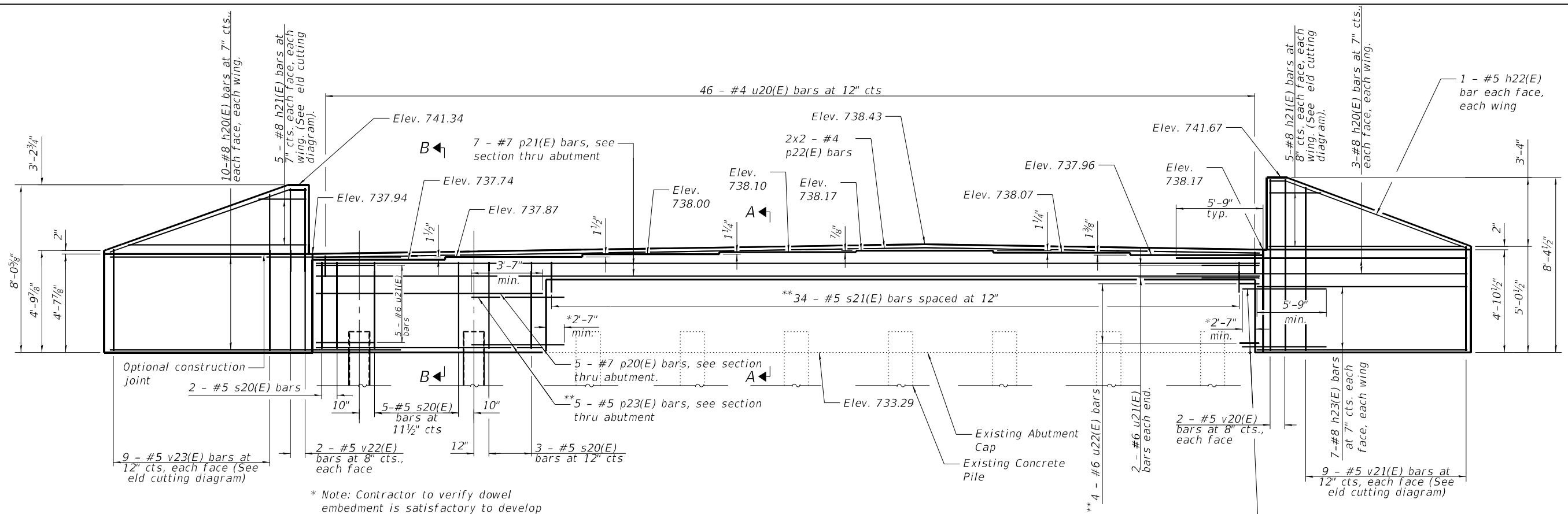

* Note: Contractor to verify dowel embedment is satisfactory to develop bars at the face of the existing concrete per method chosen and manufacturer's instructions.

** Epoxy grout bars in accordance with Article 584 of the Standard Specifications. Cost is included with Reinforcement bars, epoxy coated.

MINIMUM BAR LAP
 #5 bar = 3'-7"
 #8 bar = 5'-9"

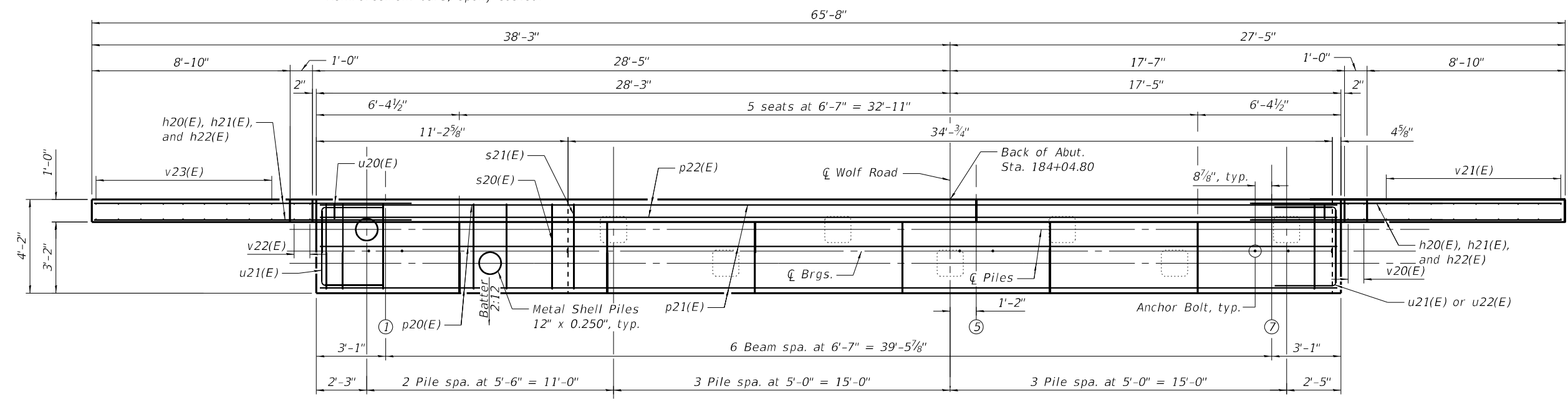

PILE DATA

Type: Metal Shell Piles 12" x 0.250" with conical tips
 Nominal Required Bearing: 354 kips
 Factored Resistance Available: 195 kips
 Est. Length: 45 ft
 No. Production Piles: 2
 No. Test Piles: 0

Notes:
 Space reinforcement in cap to miss anchor bolts.
 Pour steps monolithically with cap.
 For Bill of Material, see sheet 26 of 38.
 For details of piles see sheet 31 of 38.



USER NAME = rvandermus	DESIGNED KJA	REVISED -
CHECKED MGZM	REVISED -	
PLOT SCALE = 5.3333' / in.	DRAWN KC	REVISED -
PLOT DATE = 1/28/2022	CHECKED KJA	REVISED -

**STATE OF ILLINOIS
DEPARTMENT OF TRANSPORTATION**

**NORTH ABUTMENT PLAN AND ELEVATION
STRUCTURE NO. 099-0192**

SHEET 24 OF 38 SHEETS

F.A.U. RTE.	SECTION	COUNTY	TOTAL SHEETS	SHEET NO.
2688	2020-250-BY	WILL	133	86
			CONTRACT NO. 62N20	
ILLINOIS				

MODEL: Default
 FILE NAME: p:\projects\primera\pw\01\Documents\01\Projects\2020\20200425\01_WO_1-3 - Wolf Road over I-80\Drawings\Current Drawing Files\CADD_Sheets\Structural\Wolf Road_SHT25_SouthAbutmentPlan&Elevation.dgn
 IDOT Phase II Various Design\2020\20200425\01 - IDOT Phase II Various Design\01\Projects\2020\20200425\01_WO_1-3 - Wolf Road over I-80\Drawings\Current Drawing Files\CADD_Sheets\Structural\Wolf Road_SHT25_SouthAbutmentPlan&Elevation.dgn
 1/28/2022 3:17:46 PM

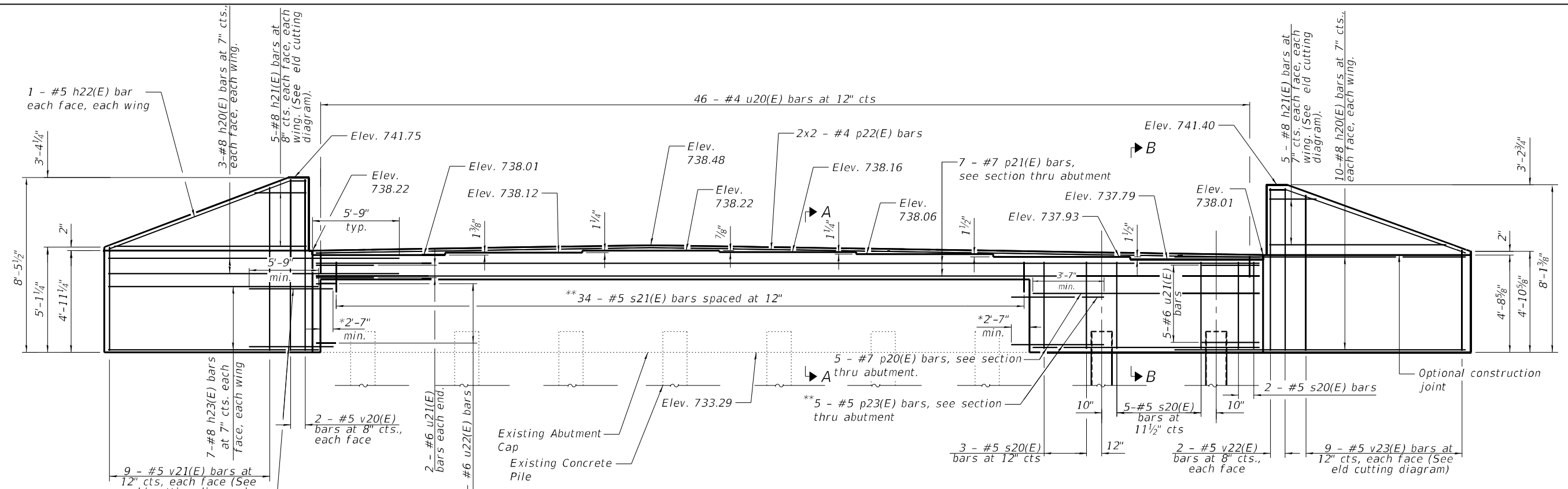

** 7 - #8 h24(E) bars each face of wingwall, lap with each h23(E) bar

* Note: Contractor to verify dowel embedment is satisfactory to develop bars at the face of the existing concrete per method chosen and manufacturer's instructions.
 ** Epoxy grout bars in accordance with Article 584 of the Standard Specifications. Cost is included with Reinforcement bars, epoxy coated.

ELEVATION
 (Looking South)

MINIMUM BAR LAP
 #5 bar = 3'-7"
 #8 bar = 5'-9"

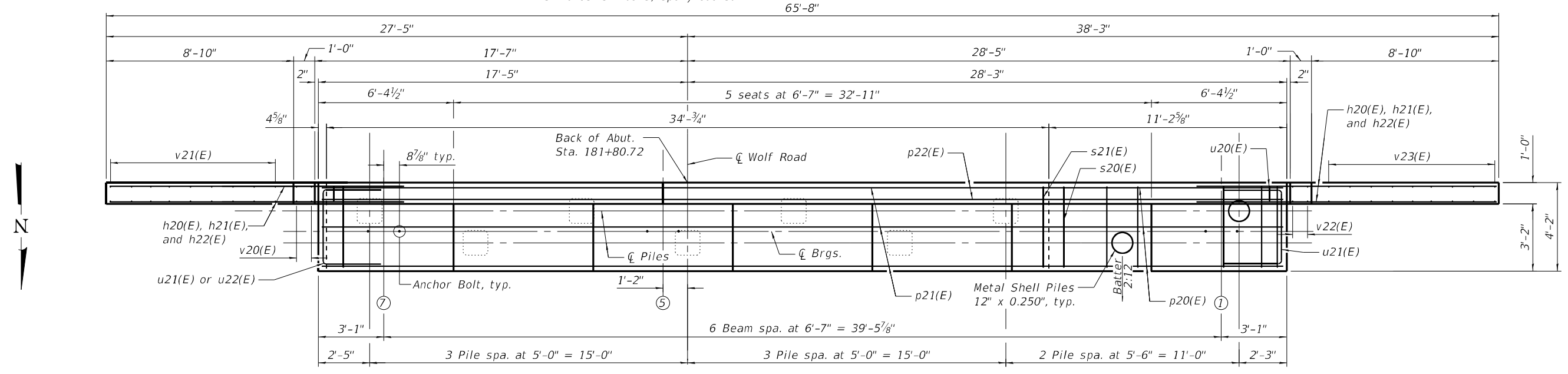

PLAN

PILE DATA

Type: Metal Shell Piles 12" x 0.250" with conical tips
 Nominal Required Bearing: 359 kips
 Factored Resistance Available: 197 kips
 Est. Length: 45 ft
 No. Production Piles: 2
 No. Test Piles: 0

Notes:
 Space reinforcement in cap to miss anchor bolts.
 Pour steps monolithically with cap.
 For Bill of Material, see sheet 26 of 38.
 For details of piles see sheet 31 of 38.



USER NAME = rvandermus	DESIGNED KJA	REVISED -
CHECKED MGZM	REVISED -	
PLOT SCALE = 5.3333' / in.	DRAWN KC	REVISED -
PLOT DATE = 1/28/2022	CHECKED KJA	REVISED -

STATE OF ILLINOIS
DEPARTMENT OF TRANSPORTATION

SOUTH ABUTMENT PLAN AND ELEVATION
STRUCTURE NO. 099-0192

SHEET 25 OF 38 SHEETS

F.A.U. RTE.	SECTION	COUNTY	TOTAL SHEETS	SHEET NO.
2688	2020-250-BY	WILL	133	87
			CONTRACT NO. 62N20	
ILLINOIS				

MODEL: Default
 FILE NAME: p:\primeira-pw\ben\p\primeira-pw\01\Documents\01\Projects\2020\20200425\01_WO_1-3 - Wolf Road over I-80\Drawings\Current Drawing Files\CADD_Sheets\Structural\Wolf Road_SHT26_AbumentDetails.dgn
 IDOT Phase II Various Design\2020\20200425\01 - IDOT Phase II Various Design\2020\20200425\01_WO_1-3 - Wolf Road over I-80\Drawings\Current Drawing Files\CADD_Sheets\Structural\Wolf Road_SHT26_AbumentDetails.dgn
 1/28/2022 3:17:49 PM

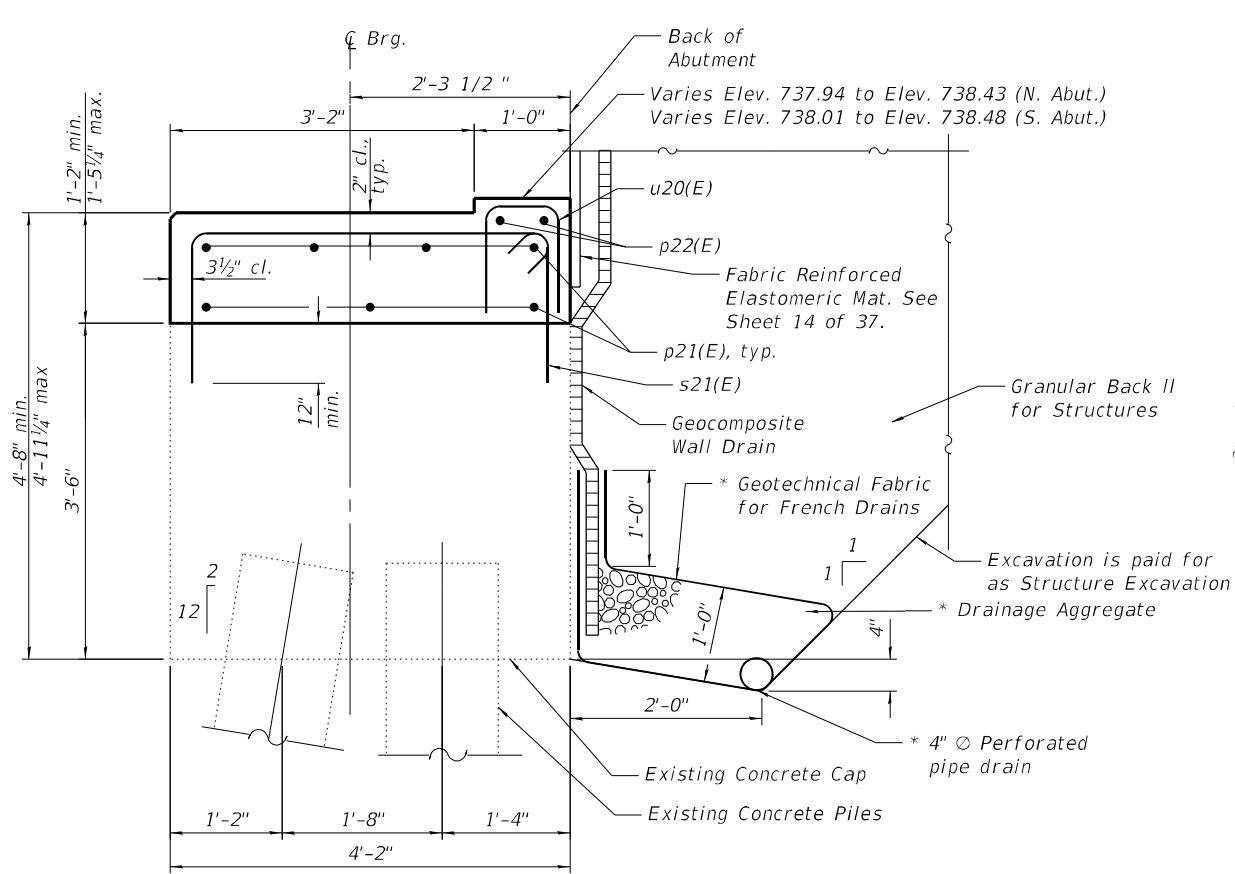

SECTION A-A

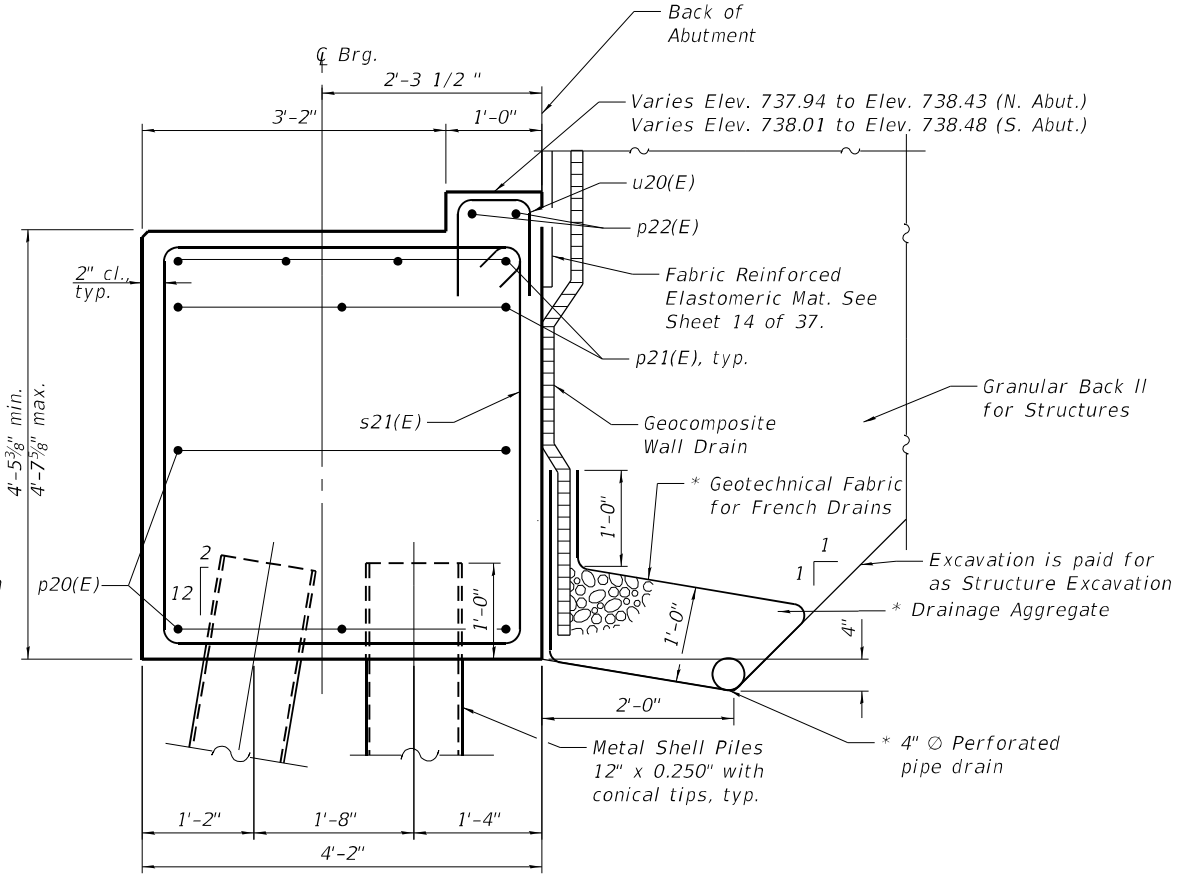

SECTION B-B

* Included in the cost of Pipe Underdrains for Structures

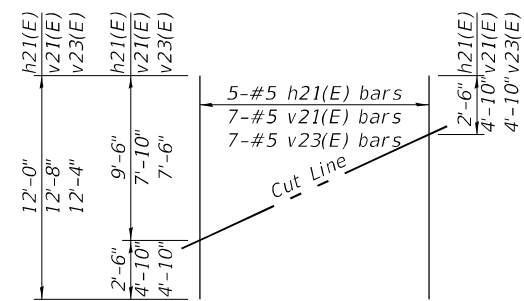

FIELD CUTTING DIAGRAM

Order h21(E), v21(E) and v23(E) full length. Cut as shown and use remainder of bars in opposite wing.

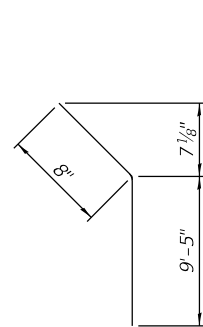

BAR h22(E)

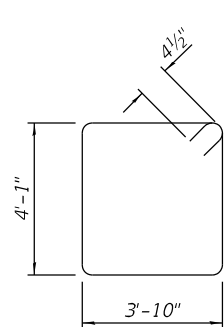

BAR s20(E)

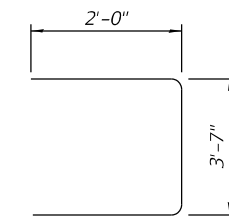

BAR s21(E)

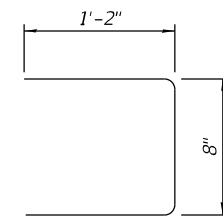

BAR u20(E)

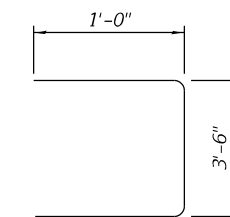

BAR u22(E)

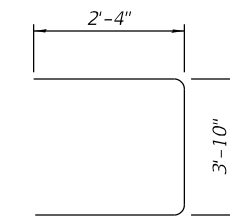

BAR u21(E)

TWO ABUTMENTS
BILL OF MATERIAL

Bar	No.	Size	Length	Shape
h20(E)	52	#8	15'-7"	—————
h21(E)	20	#8	12'-0"	—————
h22(E)	8	#5	10'-1"	—————
h23(E)	28	#8	9'-8"	—————
h24(E)	28	#8	8'-2"	—————
p20(E)	10	#7	10'-11"	—————
p21(E)	14	#7	45'-4"	—————
p22(E)	8	#4	25'-7"	—————
p23(E)	10	#5	6'-2"	—————
s20(E)	20	#5	16'-7"	□
s21(E)	68	#5	7'-7"	□
u20(E)	92	#4	3'-0"	□
u21(E)	14	#6	8'-6"	□
u22(E)	8	#6	5'-6"	□
v20(E)	8	#5	8'-2"	—————
v21(E)	18	#5	12'-8"	—————
v22(E)	8	#5	7'-10"	—————
v23(E)	18	#5	12'-4"	—————
Structure Excavation			Cu. Yd.	63
Concrete Structures			Cu. Yd.	42.8
Reinforcement Bars, Epoxy Coated			Pound	7,860
Furn. Metal Shell Piles 12" x 0.250"			Foot	180
Driving Piles			Foot	180
Pile Shoes			Each	4
Slope Wall, 4 inch			Sq. Yd.	478
Granular Back II for Structures			Cu. Yd.	382
Geocomposite Wall Drain			Sq. Yd.	99
Pipe Underdrain for Structures, 4 in			Foot	136

Notes:
Pour steps monolithically with cap.
For details of piles see sheet 31 of 38.



USER NAME = rvandermus	DESIGNED KJA	REVISED -
PLOT SCALE = 2.0000' / in.	CHECKED MG/ZM	REVISED -
PLOT DATE = 1/28/2022	DRAWN KC	REVISED -
	CHECKED KJA	REVISED -

STATE OF ILLINOIS
DEPARTMENT OF TRANSPORTATION

ABUTMENT DETAILS
STRUCTURE NO. 099-0192

SHEET 26 OF 38 SHEETS

F.A.U. RTE.	SECTION	COUNTY	TOTAL SHEETS	SHEET NO.
2688	2020-250-BY	WILL	133	88
			CONTRACT NO. 62N20	
ILLINOIS				

Notes:
 Space reinforcement in cap to miss anchor bolts.
 Pour steps monolithically with cap.
 The Contractor shall be responsible for using driving methods that do not damage the existing structure during pile installation, nor cause settlement or differential movement of the existing spread footing.
 All exposed surface areas shall be treated with Concrete Sealer. Concrete Sealer shall only be applied to new concrete.
 For details of piles see sheet 31 of 38.

MINIMUM BAR LAP

#5 = 3'-7"
 #9 = 5'-8"

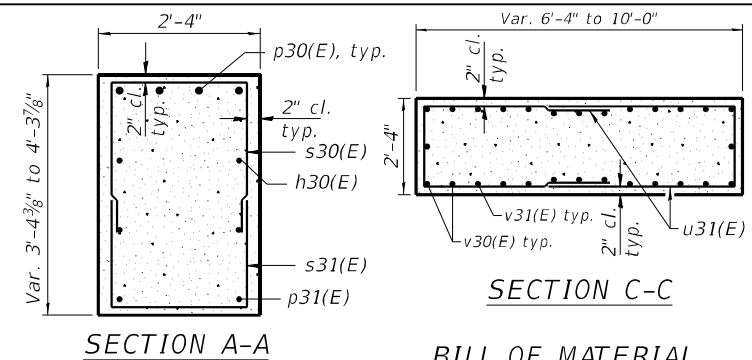
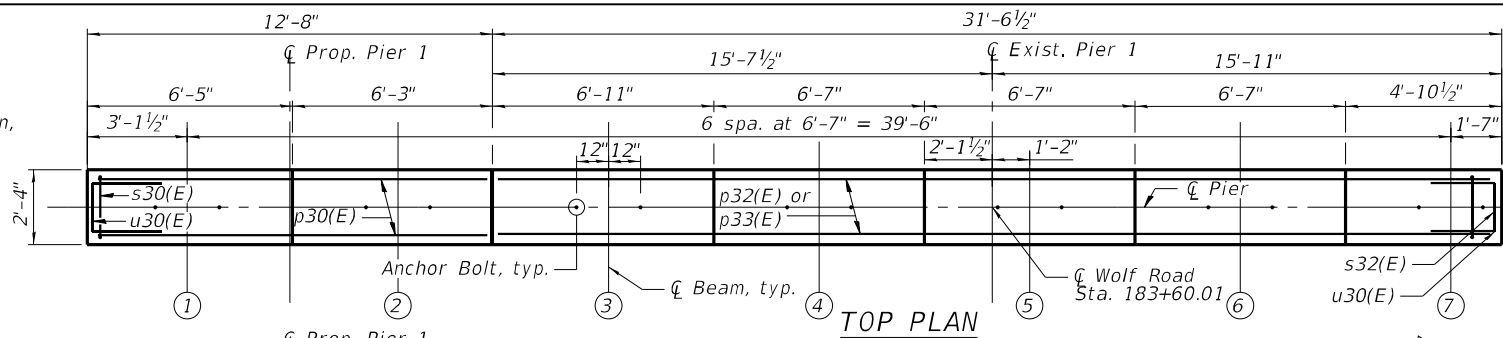

BILL OF MATERIAL

Bar	No.	Size	Length	Shape
h30(E)	6	#5	12'-4"	—
h31(E)	16	#5	14'-2"	—
h32(E)	48	#4	5'-1"	—
n30(E)	28	#9	9'-6"	⌋
n31(E)	14	#9	10'-8"	⌋
p30(E)	4	#9	15'-6"	⌋
p31(E)	2	#5	12'-6"	—
p32(E)	4	#9	31'-2"	—
p33(E)	4	#9	22'-9"	—
s30(E)	21	#5	8'-2"	⌋
s31(E)	31	#4	6'-3"	⌋
sp30(E)	8	#4	41'-6"	⌋
t30(E)	73	#8	9'-4"	—
u30(E)	12	#6	10'-8"	⌋
u31(E)	32	#5	14'-0"	⌋
v30(E)	10	#9	15'-11"	—
v31(E)	18	#9	18'-11"	—
v32(E)	4	#9	7'-0"	—
v33(E)	112	#7	42'-8"	⌋
w30(E)	36	#8	19'-4"	—
Structure Excavation		Cu. Yd.	57	
Concrete Structures		Cu. Yd.	42.7	
Reinforcement Bars, Epoxy Coated		Pound	20,590	
Furn. Metal Shell Piles 16"x0.375"		Foot	462	
Test Pile, Metal Shells		Each	1	
Driving Piles		Foot	462	
Pile Shoes		Each	8	
Granular Backfill for Structures		Cu. Yd.	45	
Concrete Sealer		Sq. Ft.	525	
Name Plate		Each	1	

** Length is height of spiral
 Minimum lap for spirals = 2'-7"

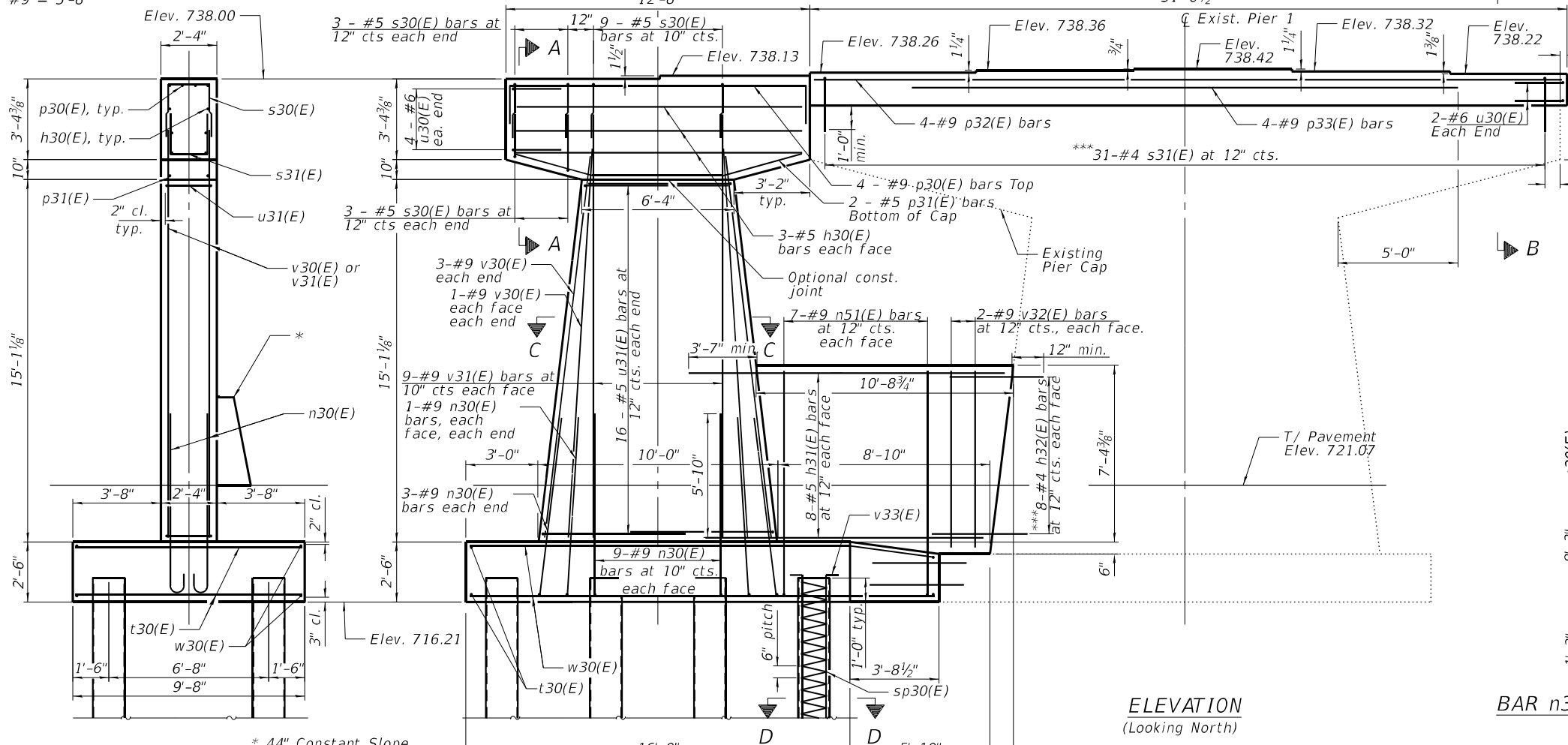

ELEVATION
 (Looking North)

*** Epoxy grout bars in accordance with Article 584 of the Standard Specifications. Cost is included with Reinforcement bars, epoxy coated.

BAR n30(E) & n31(E)

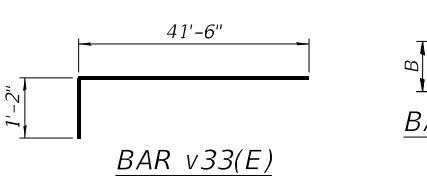
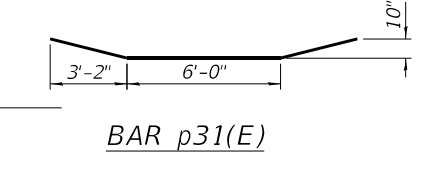
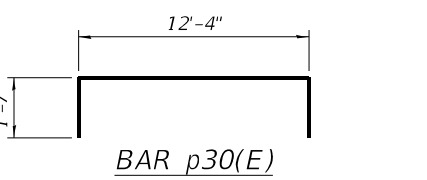

A & B DIMENSIONS

Bar	A	B
s30(E)	2'-0"	3'-1"
s31(E)	1'-11"	2'-2"
u30(E)	2'-0"	4'-4"
u31(E)	2'-0"	6'-0"

END VIEW
 (Looking East)

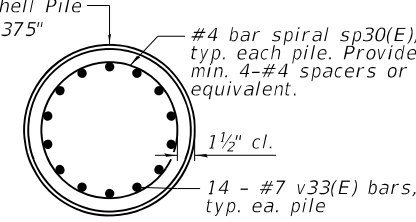

SECTION D-D

PILE DATA

Type: Metal Shell Piles 16" x 0.375" with conical tips
 Nominal Required Bearing: 532 kip
 Factored Resistance Available: 293 kip
 Est. Length: 66 ft
 No. Production Piles: 7
 No. Test Piles: 1

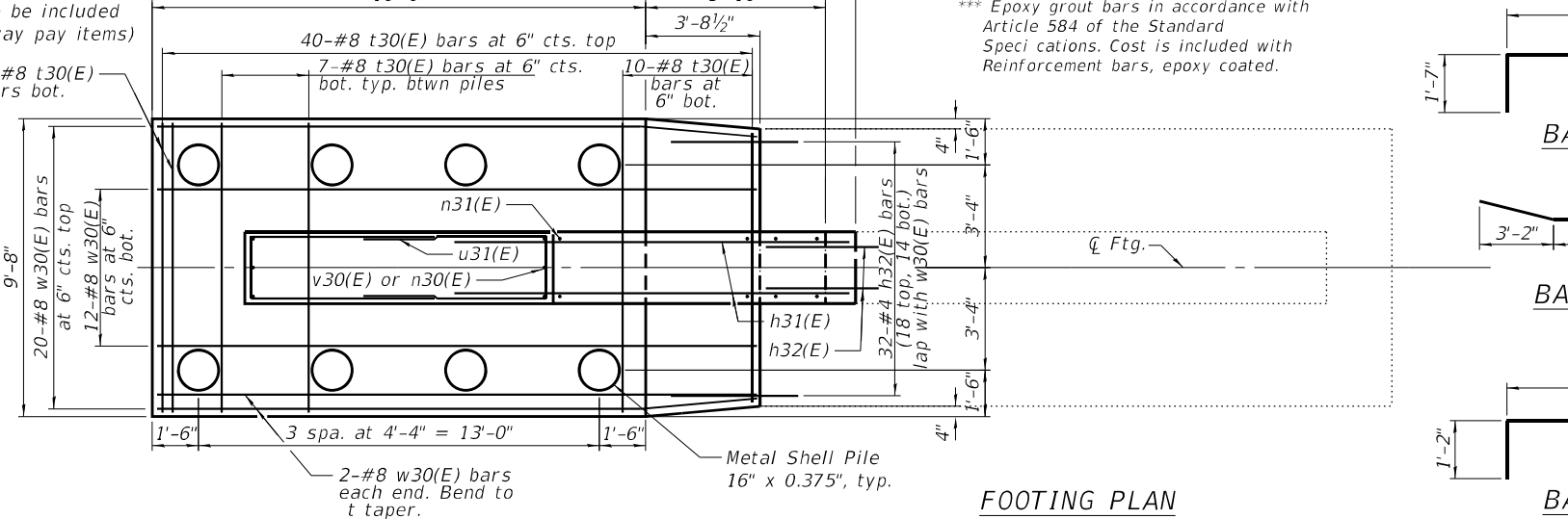

FOOTING PLAN

STATE OF ILLINOIS
DEPARTMENT OF TRANSPORTATION

PIER 1 WIDENING
STRUCTURE NO. 099-0192

F.A.U. RTE.	SECTION	COUNTY	TOTAL SHEETS	SHEET NO.
2688	2020-250-BY	WILL	STOT	\$str027
				CONTRACT NO. 62N20



Notes:
 Space reinforcement in cap to miss anchor bolts.
 Pour steps monolithically with cap.
 The Contractor shall be responsible for using driving methods that do not damage the existing structure during pile installation, nor cause settlement or differential movement of the existing spread footing.
 All exposed surface areas shall be treated with Concrete Sealer. Concrete Sealer shall only be applied to new concrete.
 For details of piles see sheet 31 of 38.

MINIMUM BAR LAP

#5 = 3'-7"
 #9 = 5'-8"

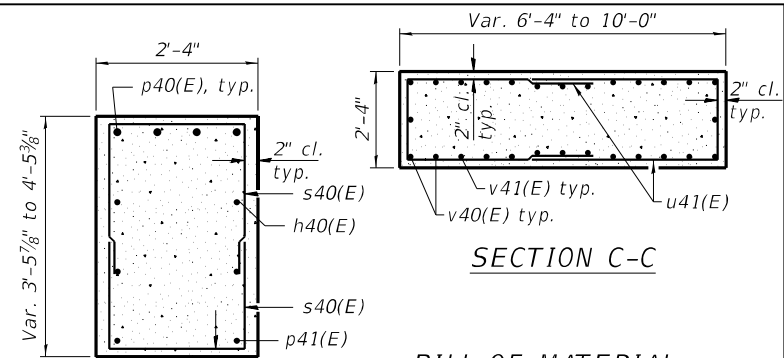
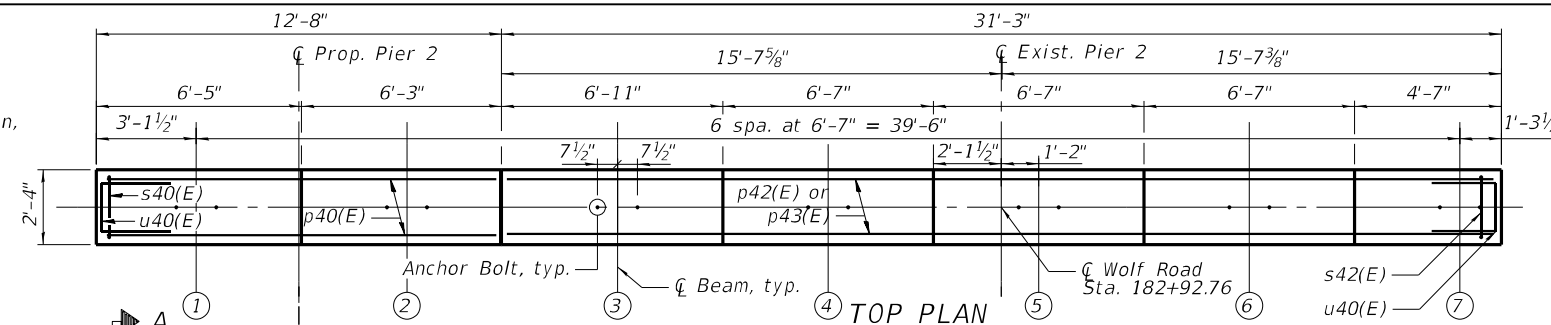

BILL OF MATERIAL

Bar	No.	Size	Length	Shape
h40(E)	6	#5	12'-4"	—
h41(E)	16	#5	14'-2"	—
h42(E)	20	#4	5'-1"	—
n40(E)	28	#9	9'-6"	C
n41(E)	20	#9	9'-9"	C
p40(E)	4	#9	15'-6"	L
p41(E)	2	#5	12'-6"	—
p42(E)	4	#9	30'-11"	—
p43(E)	4	#9	22'-9"	—
s40(E)	21	#5	8'-4"	□
s41(E)	31	#4	6'-5"	□
sp40(E)	8	#4	41'-6"	~
t40(E)	82	#8	9'-4"	—
u40(E)	12	#6	10'-8"	—
u41(E)	30	#5	14'-0"	—
v40(E)	10	#9	15'-6"	—
v41(E)	18	#9	18'-7"	—
v42(E)	112	#7	42'-8"	—
w40(E)	36	#8	21'-8"	—
Structure Excavation		Cu. Yd.	53	
Concrete Structures		Cu. Yd.	44.7	
Reinforcement Bars, Epoxy Coated		Pound	20,950	
Furn. Metal Shell Piles 16" x 0.375"		Foot	378	
Test Pile, Metal Shells		Each	1	
Driving Piles		Foot	378	
Pile Shoes		Each	8	
Granular Backfill for Structures		Cu. Yd.	32	
Concrete Sealer		Sq. Ft.	542	

** Length is height of spiral
 Minimum lap for spirals = 2'-7"

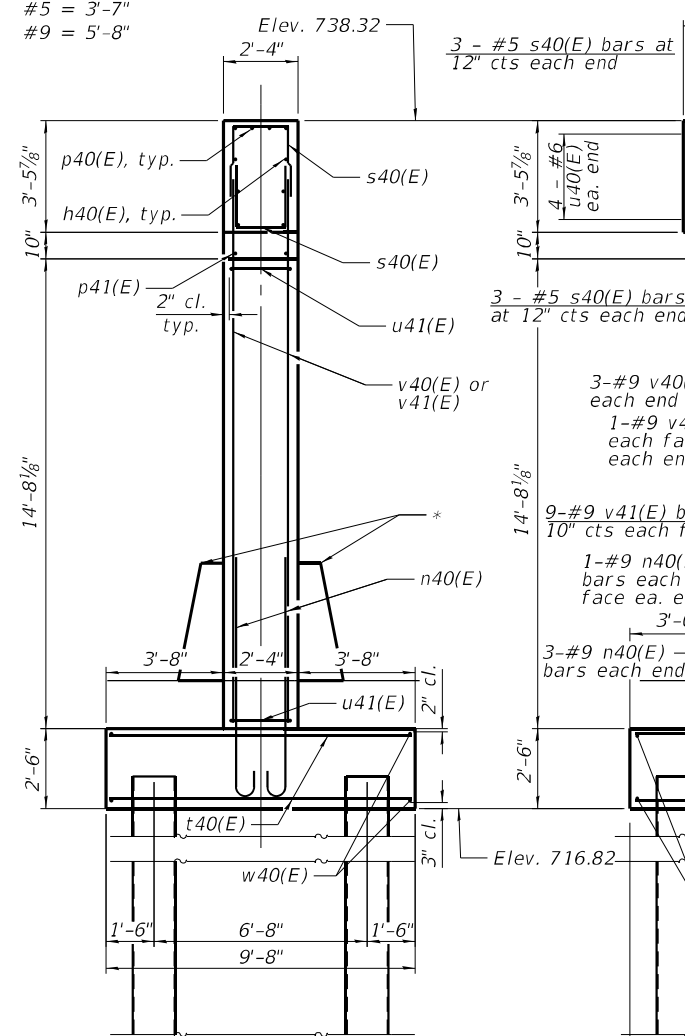

END VIEW (Looking East)

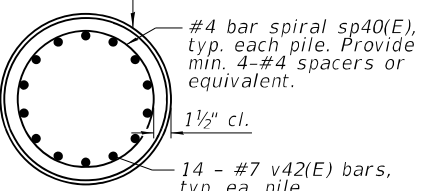

SECTION D-D

PILE DATA

Type: Metal Shell Piles 16" x 0.375" with conical tips
 Nominal Required Bearing: 527 kip
 Factored Resistance Available: 290 kip
 Est. Length: 54 ft
 No. Production Piles: 7
 No. Test Piles: 1

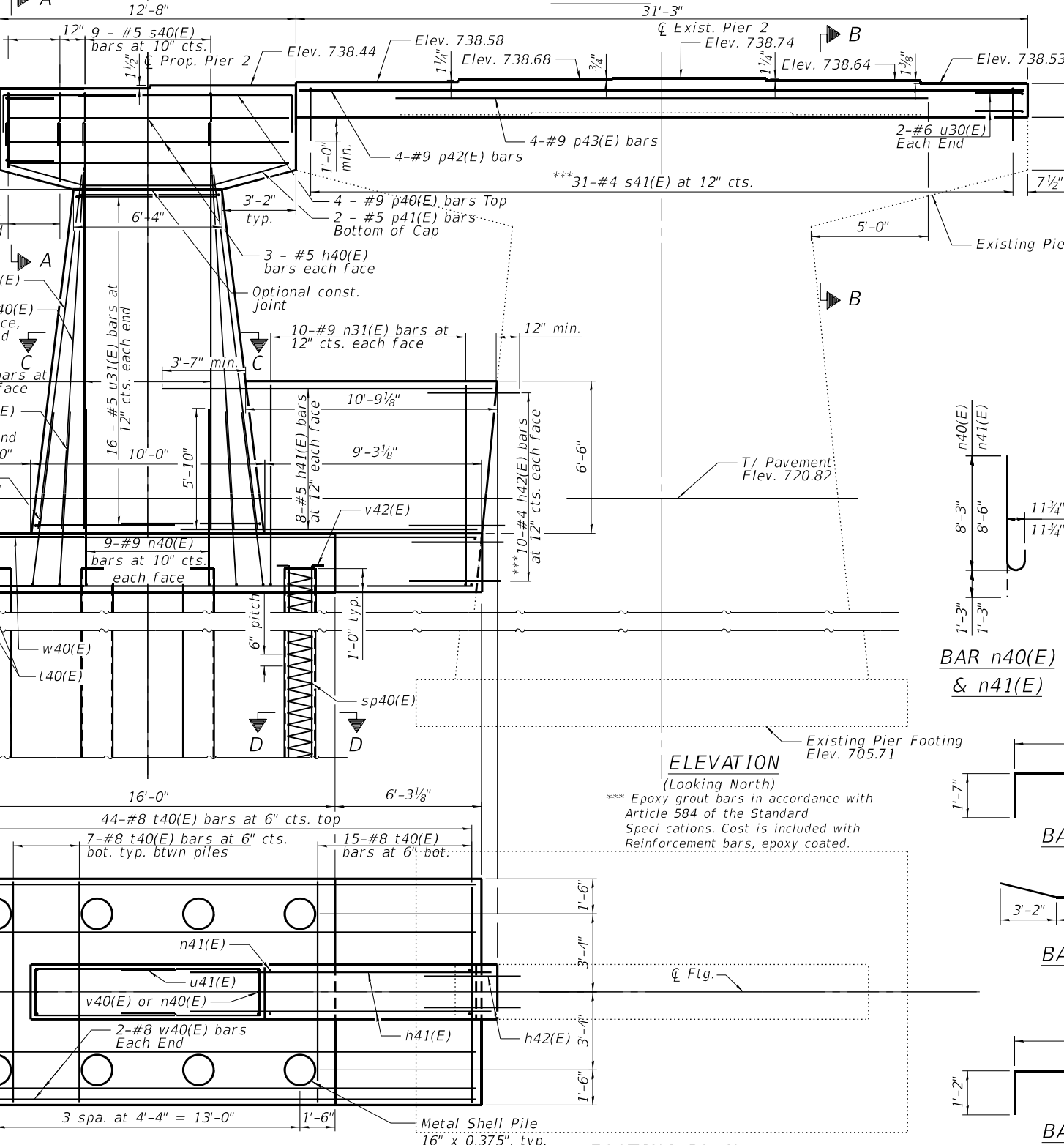

FOOTING PLAN

ELEVATION (Looking North)

*** Epoxy grout bars in accordance with Article 584 of the Standard Specifications. Cost is included with Reinforcement bars, epoxy coated.

BAR n40(E) & n41(E)

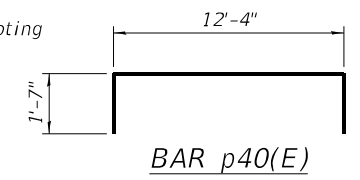

BAR p40(E)

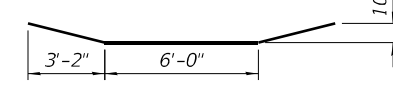

BAR p41(E)

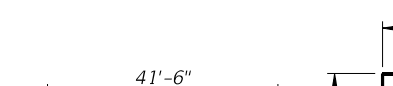

BAR v43(E)

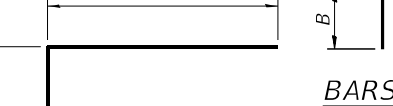

BARS s40(E), s41(E) u40(E) & u41(E)

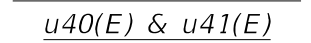

A & B DIMENSIONS

Bar	A	B
s40(E)	2'-0"	3'-2"
s41(E)	1'-11"	2'-3"
u40(E)	2'-0"	4'-4"
u41(E)	2'-0"	6'-0"

Notes:
 Space reinforcement in cap to miss anchor bolts.
 Pour steps monolithically with cap.
 The Contractor shall be responsible for using driving methods that do not damage the existing structure during pile installation, nor cause settlement or differential movement of the existing spread footing.
 All exposed surface areas shall be treated with Concrete Sealer. Concrete Sealer shall only be applied to new concrete.
 For details of piles see sheet 31 of 38.

MINIMUM BAR LAP

#5 = 3'-7"
 #9 = 5'-8"

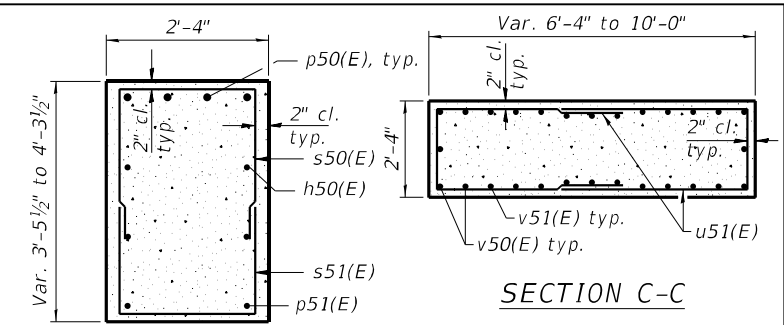
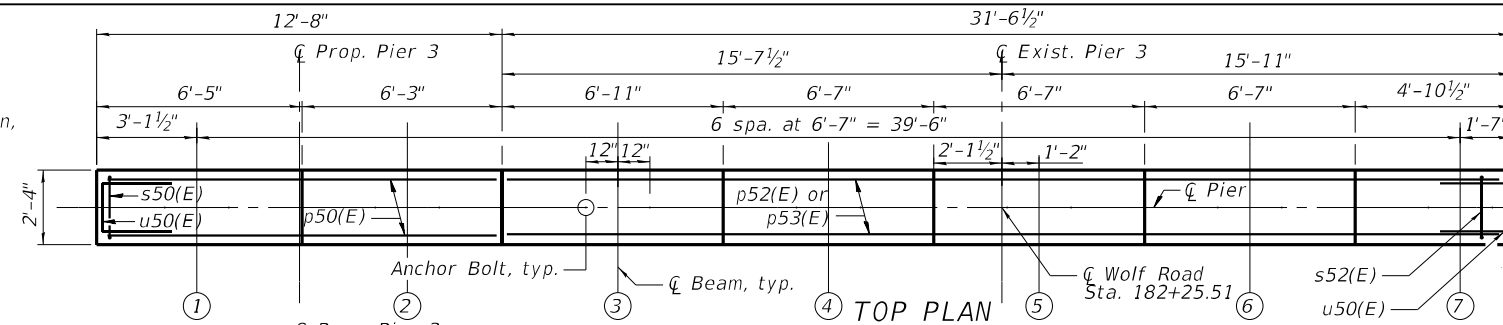

BILL OF MATERIAL

Bar	No.	Size	Length	Shape
h50(E)	6	#5	12'-4"	—
h51(E)	16	#5	14'-4"	—
h52(E)	20	#4	5'-1"	—
n50(E)	28	#9	9'-6"	C
n51(E)	20	#9	9'-9"	C
p50(E)	4	#9	15'-6"	—
p51(E)	2	#5	12'-6"	—
p52(E)	4	#9	31'-2"	—
p53(E)	4	#9	22'-9"	—
s50(E)	21	#5	8'-4"	□
s51(E)	31	#4	6'-5"	□
sp50(E)	8	#4	41'-6"	~
t50(E)	83	#8	9'-4"	—
u50(E)	12	#6	10'-8"	—
u51(E)	30	#5	14'-0"	—
v50(E)	10	#9	15'-2"	—
v51(E)	18	#9	18'-3"	—
v52(E)	112	#7	42'-8"	—
w50(E)	36	#8	21'-10"	—
Structure Excavation		Cu. Yd.	53	
Concrete Structures		Cu. Yd.	44.6	
Reinforcement Bars, Epoxy Coated		Pound	20,970	
Furn. Metal Shell Piles 16" x 0.375"		Foot	378	
Test Pile, Metal Shells		Each	1	
Driving Piles		Foot	378	
Pile Shoes		Each	8	
Granular Backfill for Structures		Cu. Yd.	32	
Concrete Sealer		Sq. Ft.	536	

** Length is height of spiral
 Minimum lap for spirals = 2'-7"

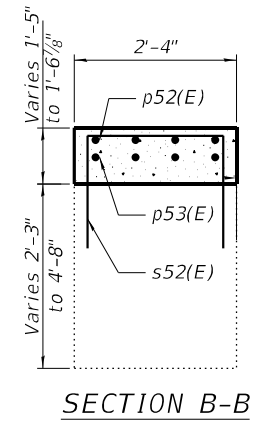
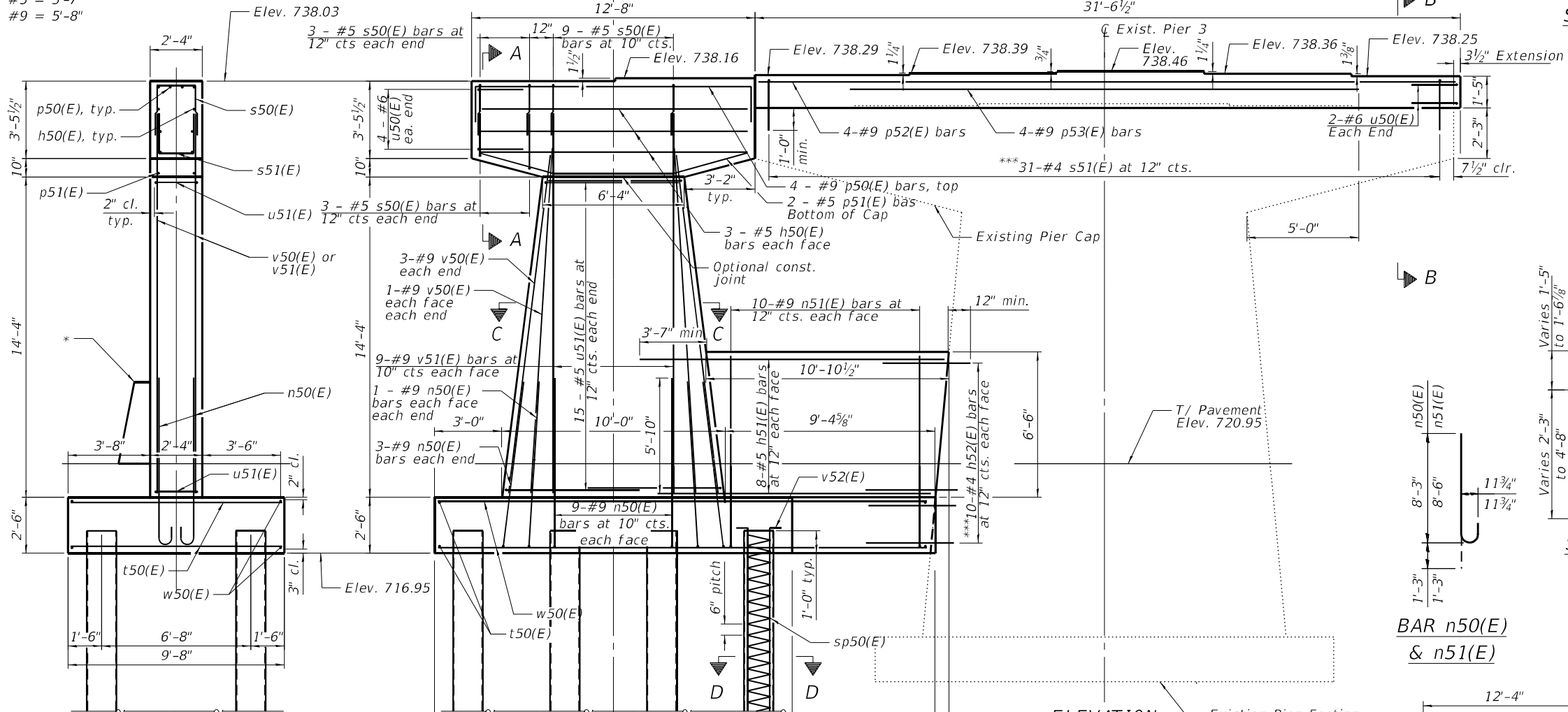

BAR n50(E) & n51(E)

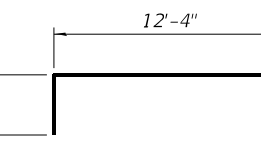

BAR p50(E)

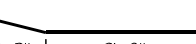

BAR p51(E)

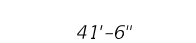

BAR v52(E)

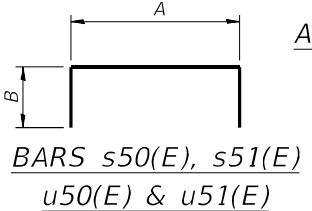

A & B DIMENSIONS

Bar	A	B
s50(E)	2'-0"	3'-2"
s51(E)	1'-11"	2'-3"
u50(E)	2'-0"	4'-4"
u51(E)	2'-0"	6'-0"

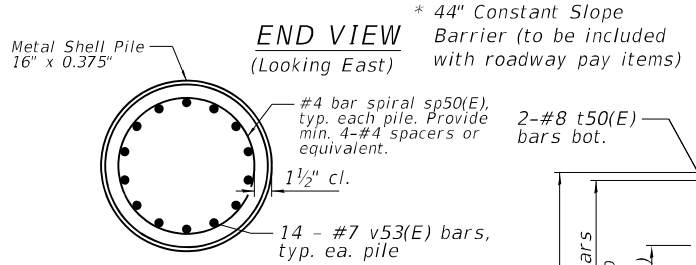

SECTION D-D

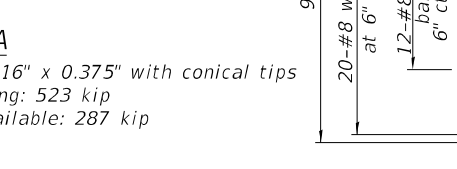

PILE DATA

Type: Metal Shell Piles 16" x 0.375" with conical tips
 Nominal Required Bearing: 523 kip
 Factored Resistance Available: 287 kip
 Est. Length: 54 ft
 No. Production Piles: 7
 No. Test Piles: 1

FOOTING PLAN

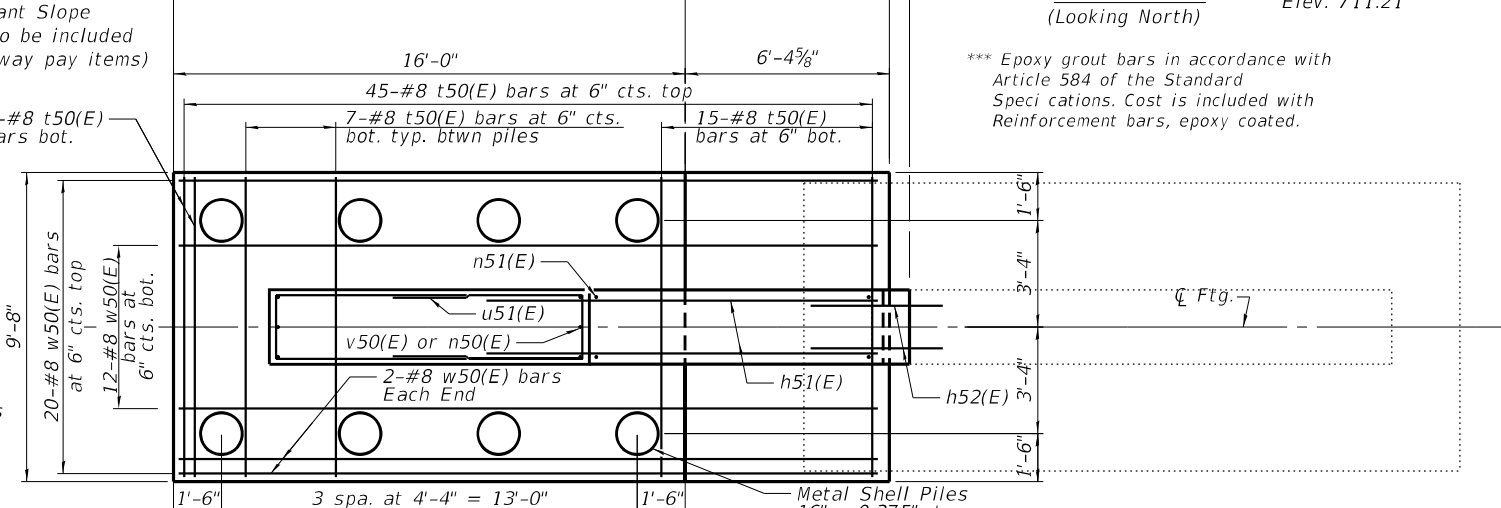

MODEL: Default
 FILE NAME: p:\pr\primera-pw\ben\key.com\primera-pw\01\Documents\01\Projects\2020\20200425\00 - IDOT Phase II Various Design\2020\20200425\01_WO_1-3 - Wolf Road over I-80\Drawings\Current Drawing Files\CADD_Sheets\Structural\Wolf Road_SHT30_PierRepairDetails.dgn
 1/28/2022 3:17:58 PM

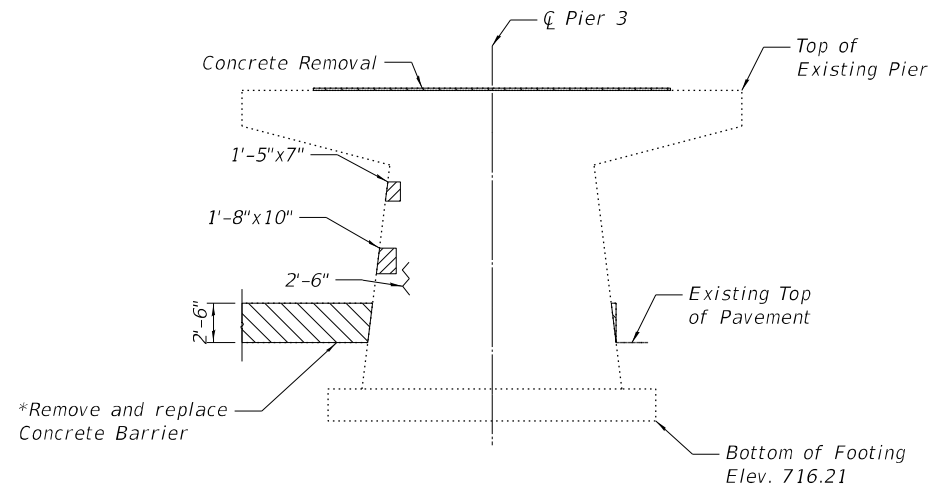

EXISTING PIER 1 REPAIR
(North Face)

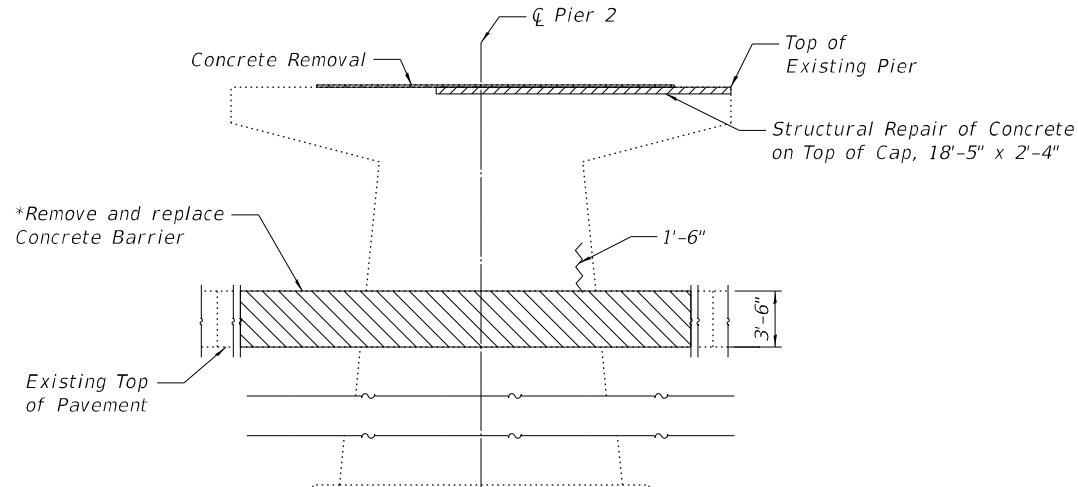

EXISTING PIER 2 REPAIR
(North Face)

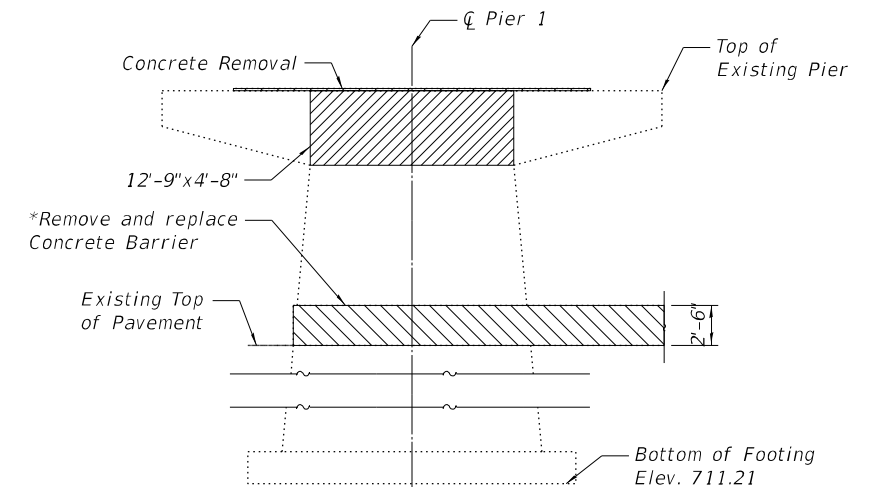

EXISTING PIER 3 REPAIR
(North Face)

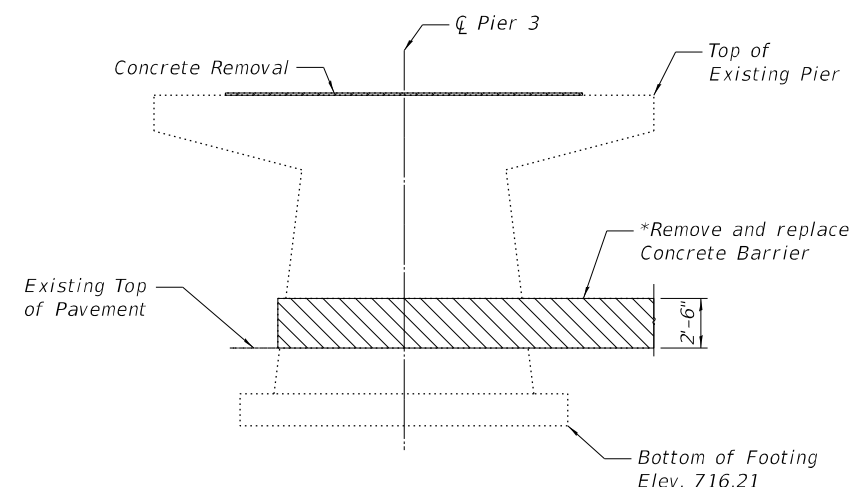

EXISTING PIER 1 REPAIR
(South Face)

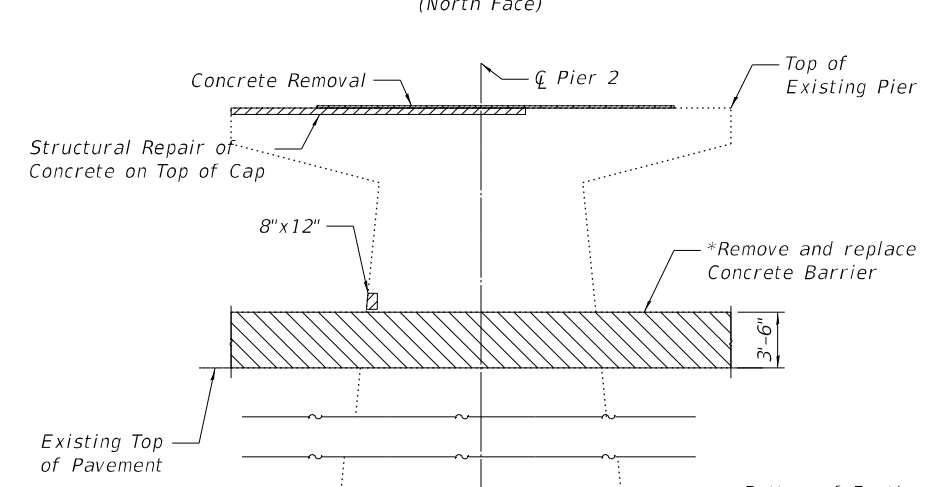

EXISTING PIER 2 REPAIR
(South Face)

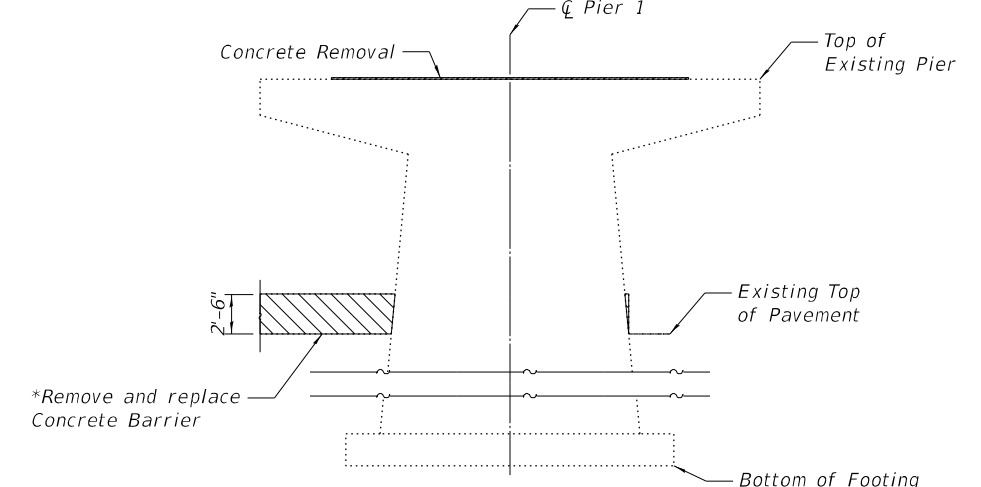

EXISTING PIER 3 REPAIR
(South Face)

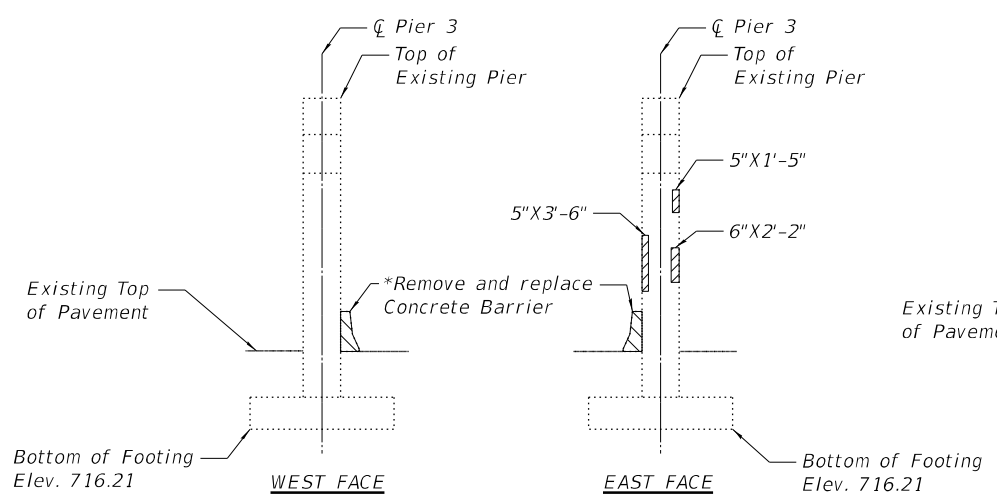

EXISTING PIER 1 REPAIR

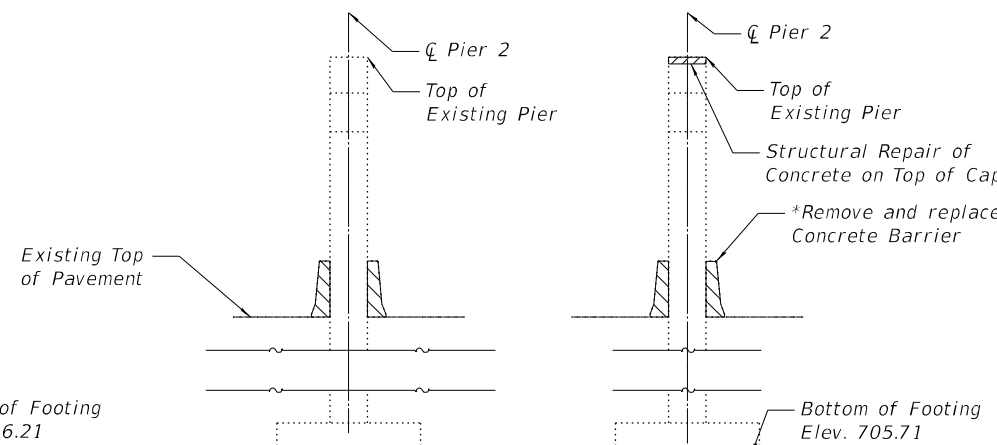

EXISTING PIER 2 REPAIR

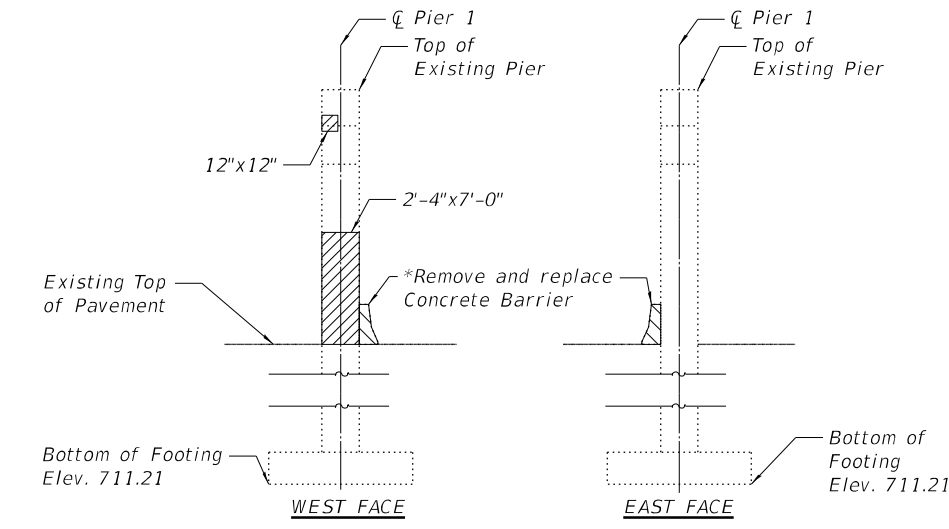

EXISTING PIER 3 REPAIR

LEGEND

- Structural Repair of Concrete (Depth Equal to or Less Than 5 Inches)
- Epoxy Crack Injection
- Concrete Removal

* To be included with roadway pay items

TOTAL BILL OF MATERIAL

ITEM	UNIT	TOTAL
Structural Repair of Concrete (Depth Equal to or less than 5 inches)	Sq. Ft.	125
Epoxy Crack Injection	Foot	4
Concrete Removal	Cu. Yd.	0.7



USER NAME =	rvandermus	DESIGNED	KJA	REVISED	-
		CHECKED	MG/ZM	REVISED	-
PLOT SCALE =	12,0000' / in.	DRAWN	KC	REVISED	-
PLOT DATE =	1/28/2022	CHECKED	KJA	REVISED	-

**STATE OF ILLINOIS
 DEPARTMENT OF TRANSPORTATION**

**PIER REPAIR DETAILS
 STRUCTURE NO. 099-0192**

SHEET 30 OF 38 SHEETS

F.A.U. RTE.	SECTION	COUNTY	TOTAL SHEETS	SHEET NO.
2688	2020-250-BY	WILL	133	92
			CONTRACT NO. 62N20	
ILLINOIS				

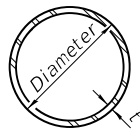

METAL SHELL PILE TABLE

Designation and outside diameter	Wall thickness t	Weight per foot (Lbs./ft.)	Inside volume (yd. ³ /ft.)
PP12	0.250"	31.37	0.0267
PP14	0.250"	36.71	0.0368
PP14	0.312"	45.61	0.0361
PP16	0.312"	52.32	0.0478
PP16	0.375"	62.64	0.0470

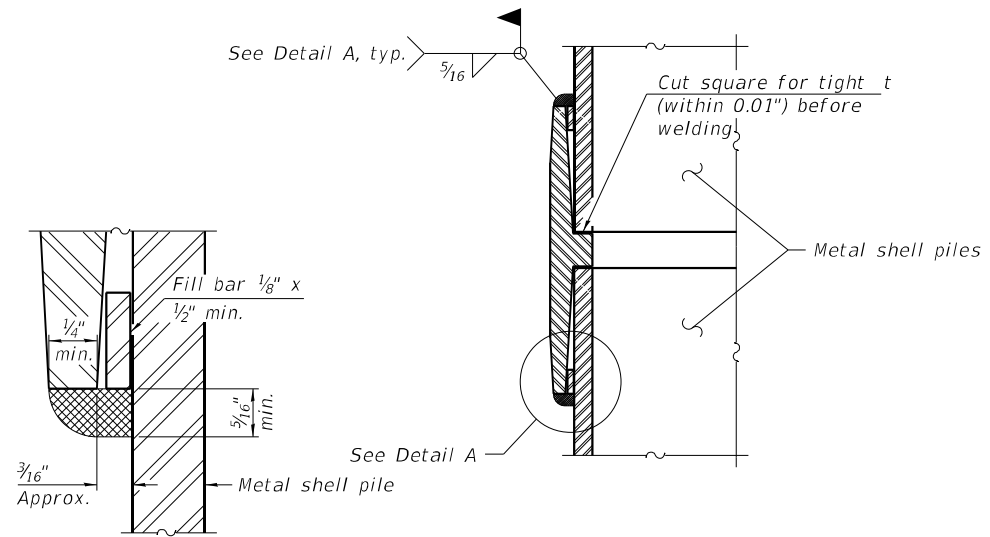

DETAIL A

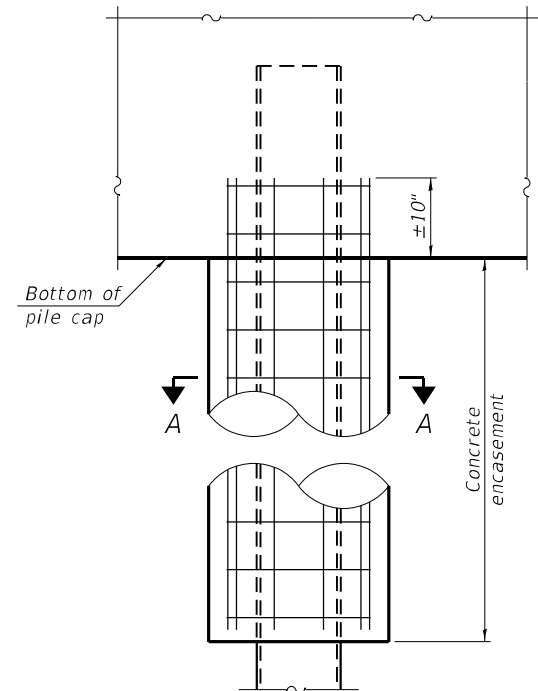

ELEVATION

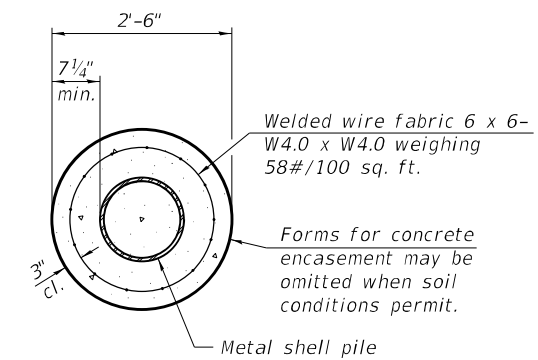

SECTION A-A

INDIVIDUAL PILE CONCRETE ENCASUREMENT
(When speci ed)

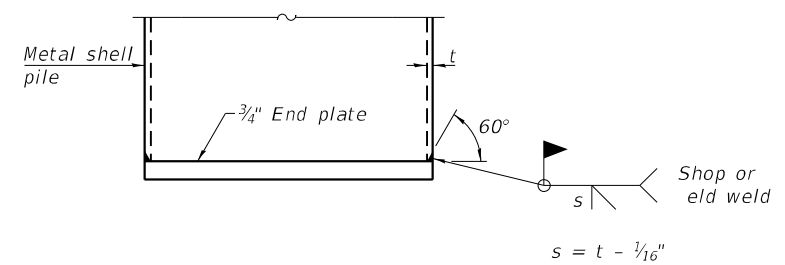

END PLATE ATTACHMENT

WELDED COMMERCIAL SPLICE
Notes:
The 1/8" x 1/2" min. II bar may be constructed of 2 bars with a 1/8" max. gap between them.
Pile segments shall be driven to solid contact with splicer before welding.

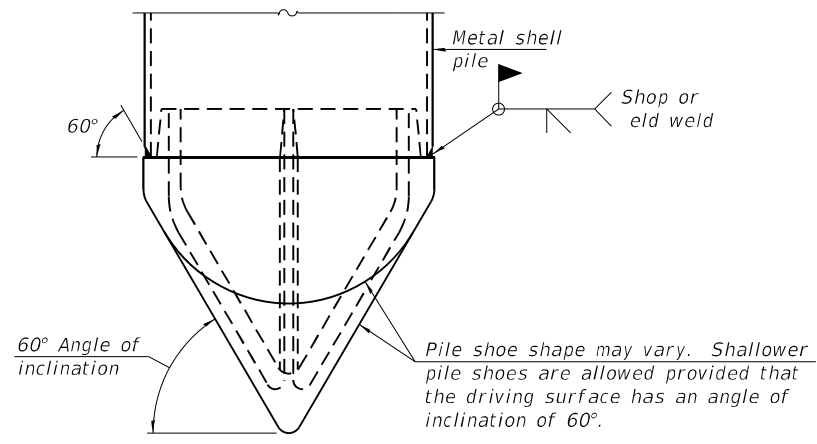

PILE SHOE ATTACHMENT

(When called for on the plans, the Contractor shall furnish metal shell pile shoes consisting of a single piece conical pile point as shown. The pile shoes shall be cast in one piece steel according to either ASTM A 148 Grade 80-50 or AASHTO M 103 Grade 65-35 and shall provide full bearing over the full circumference of the metal shell pile. The pile shoe shall have tapered leads to assure proper alignment and tting and shall be secured to the pile with a circumferential weld).

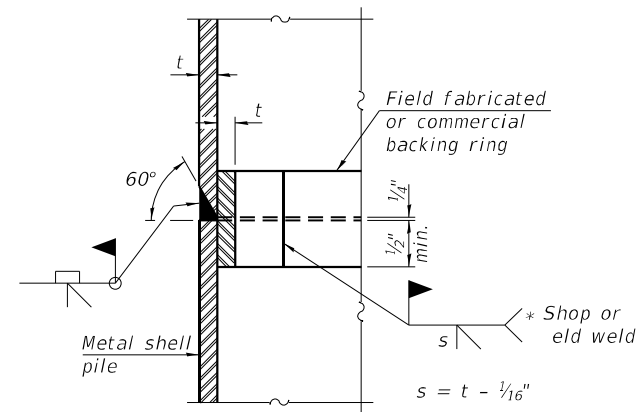

COMPLETE PENETRATION WELD SPLICE

* Field fabricated backing ring may be made from pile shell by removing segment to allow reducing circumference and vertically rejoin with partial joint penetration weld.

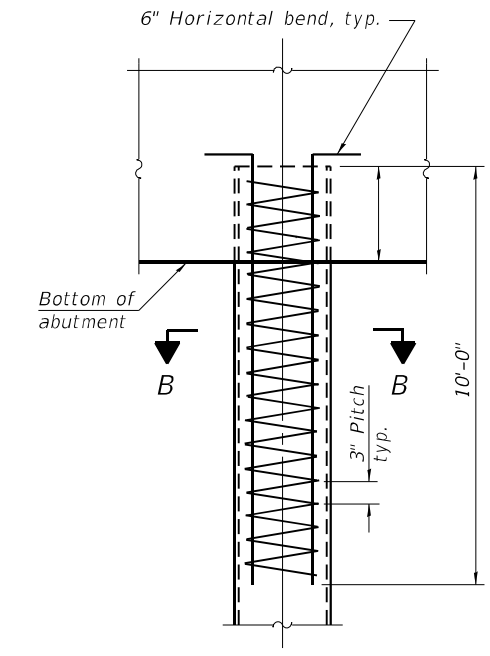

ELEVATION

REINFORCEMENT AT ABUTMENTS
(Omit when concrete encasement is speci ed)

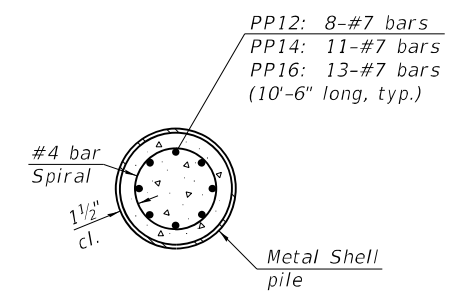

SECTION B-B

Note:
The metal shell piles shall be according to Article 1006.05 of the Standard Specifications.

MODEL: Default
FILE NAME: pwr://primera-pw-bentley.com/primera-pw-01/Projects/2020/20200425.00 - IDOT Phase II Various Design/20200425.01_WO_1-3 - Wolf Road over I-80/Drawings/Current Drawing Files/CADD_Sheets/Structural/Wolf Road_SHT31_SteelPilesDetails.dgn
1/28/2022 3:17:59 PM

F-MS

1-1-2020



USER NAME =	randeremus	DESIGNED	KJA	REVISED	-
PLOT SCALE =	2.0000' / in.	CHECKED	MG/ZM	REVISED	-
PLOT DATE =	1/28/2022	DRAWN	KC	REVISED	-
		CHECKED	KJA	REVISED	-

**STATE OF ILLINOIS
DEPARTMENT OF TRANSPORTATION**

**METAL SHELL PILE DETAILS
STRUCTURE NO. 099-0192**

SHEET 31 OF 38 SHEETS

F.A.U. RTE.	SECTION	COUNTY	TOTAL SHEETS	SHEET NO.
2688	2020-250-BY	WILL	133	93
			CONTRACT NO. 62N20	

ILLINOIS

MODEL: Default
 FILE NAME: p:\pr\primera-pw\ben\key.com\primera-pw\01\Documents\01 Projects\2020\20200425\00 - IDOT Phase II Various Design\20200425\01_WO_1-3 - Wolf Road over I-80\Drawings\Current Drawing Files\CADD_Sheets\Structural\Wolf Road_SHT33_Boringlogs.dgn
 1/28/2022 3:18:05 PM



SOIL BORING LOG

Log of Boring
GC-01
 Sheet 4 of 4

ROUTE: Federal Aid Urban - 2688 DESCRIPTION: Wolf Road over I-80
 SECTION: 99-5HB-4 DRILLER: Rubino Engineering, Inc. DATE(S) DRILLED: 01/27/2021 to 01/27/2021
 COUNTY: Will DRILLED BY: Joe Kenny LOGGED BY: Nikki Kurfman (Gonzalez)
 STRUCT. NO.: 099-0192 DRILL RIG TYPE: Geoprobe 7822DT BACKFILL: Cuttings and pavement patch
 STATION & OFFSET: DRILLING METHOD: 3-1/4" hollow stem auger Ground Water Observation(s):
 SURFACE ELEV.: 741.5 ft SAMPLING METHOD: 2" Split Spoon
 VERTICAL DATUM: NAVD83 HAMMER TYPE: Auto Hammer (140 lb) Upon Completion: 38.00 ft
 LAT/LONG: 41.552876, -87.890101 HAMMER EFFICIENCY: 88.8 % After Drilling: 24.0 hr after - Filled
 LOCATION: NE 1/4, SEC. 6, T35N, R12E, 3rd PM

Depth (ft)	Graphic	Material Description	Elevation (ft): 741.5	Sample Number	Recovery, in. (%)	Sampling Resist. Or Core RQD(%)	Rimac, Cu (tsf)	Pocket Pen. Cu (tsf)	Moisture Content (%)	Dry Unit Weight (pcf)	Liquid Limit	Plasticity Index	Depth (ft)	Remarks
64		Clay LOAM: Stiff, brown, moist, low plastic, with fine sand, some gravel; (GLACIAL TILL)	678	SS-18	18 (100)	5-11-23 N = 34	1.6 B		13				64	
66		SAND: Medium dense, gray, wet, fine- to coarse-grained, trace gravel; (GLACIAL TILL)	675.3										66	
69		CLAY: Dense, brown, moist, low plastic, with fine sand, some gravel; (GLACIAL TILL)	671.9	SS-19 A	18 (100)	11-13-11 N = 24	3.1 B		15				69	
74			668	SS-20	13 (72)	8-11-10 N = 21	1.3 B		19				74	
76		Boring terminated at 75.0'	666.5										76	



SOIL BORING LOG

Log of Boring
GC-02
 Sheet 1 of 4

ROUTE: Federal Aid Urban - 2688 DESCRIPTION: Wolf Road over I-80
 SECTION: 99-5HB-4 DRILLER: Rubino Engineering, Inc. DATE(S) DRILLED: 01/20/2021 to 01/20/2021
 COUNTY: Will DRILLED BY: Joe Kenny LOGGED BY: Nikki Kurfman (Gonzalez)
 STRUCT. NO.: 099-0192 DRILL RIG TYPE: Geoprobe 7822DT BACKFILL: Cuttings and pavement patch
 STATION & OFFSET: DRILLING METHOD: 3-1/4" hollow stem auger Ground Water Observation(s):
 SURFACE ELEV.: 721.6 ft SAMPLING METHOD: 2" Split Spoon
 VERTICAL DATUM: NAVD83 HAMMER TYPE: Auto Hammer (140 lb) Upon Completion: 41.00 ft
 LAT/LONG: 41.552588, -87.890175 HAMMER EFFICIENCY: 88.8 % After Drilling: 24.0 hr after - Filled
 LOCATION: NE 1/4, SEC. 6, T35N, R12E, 3rd PM

Depth (ft)	Graphic	Material Description	Elevation (ft): 721.6	Sample Number	Recovery, in. (%)	Sampling Resist. Or Core RQD(%)	Rimac, Cu (tsf)	Pocket Pen. Cu (tsf)	Moisture Content (%)	Dry Unit Weight (pcf)	Liquid Limit	Plasticity Index	Depth (ft)	Remarks
1		CONCRETE	720.6										1	
2		CRUSHED STONE	720	SS-1	12 (67)	16-10-8 N = 18							2	
4		CLAY: Stiff, brown, moist, low plastic, with fine sand; (GLACIAL TILL)	718.4	SS-2	13 (1)	6-5-9 N = 14	2.7 B		10				4	
6			716	SS-3	17 (95)	3-4-6 N = 10	2.7 B		17				6	
9			712	SS-4	18 (100)	4-4-5 N = 9	3.5 B		12				9	
11			710	SS-5	2 (11)	3-4-5 N = 9			16				11	
14		CLAY (A-6(11)): Stiff, gray, moist, low plastic, some fine to coarse sand, some gravel; (GLACIAL TILL)	708.3	SS-6	15 (83)	2-4-6 N = 10	3.7 B		18	33	14		14	
16			706	SS-7	0 (0)	4-6-1 N = 7			19				16	
19			702	SS-8	18 (100)	3-4-7 N = 11	2.7 B		18				19	



SOIL BORING LOG

Log of Boring
GC-02
 Sheet 2 of 4

ROUTE: Federal Aid Urban - 2688 DESCRIPTION: Wolf Road over I-80
 SECTION: 99-5HB-4 DRILLER: Rubino Engineering, Inc. DATE(S) DRILLED: 01/20/2021 to 01/20/2021
 COUNTY: Will DRILLED BY: Joe Kenny LOGGED BY: Nikki Kurfman (Gonzalez)
 STRUCT. NO.: 099-0192 DRILL RIG TYPE: Geoprobe 7822DT BACKFILL: Cuttings and pavement patch
 STATION & OFFSET: DRILLING METHOD: 3-1/4" hollow stem auger Ground Water Observation(s):
 SURFACE ELEV.: 721.6 ft SAMPLING METHOD: 2" Split Spoon
 VERTICAL DATUM: NAVD83 HAMMER TYPE: Auto Hammer (140 lb) Upon Completion: 41.00 ft
 LAT/LONG: 41.552588, -87.890175 HAMMER EFFICIENCY: 88.8 % After Drilling: 24.0 hr after - Filled
 LOCATION: NE 1/4, SEC. 6, T35N, R12E, 3rd PM

Depth (ft)	Graphic	Material Description	Elevation (ft): 721.6	Sample Number	Recovery, in. (%)	Sampling Resist. Or Core RQD(%)	Rimac, Cu (tsf)	Pocket Pen. Cu (tsf)	Moisture Content (%)	Dry Unit Weight (pcf)	Liquid Limit	Plasticity Index	Depth (ft)	Remarks
22		CLAY (A-6(11)): Stiff, gray, moist, low plastic, some fine to coarse sand, some gravel; (GLACIAL TILL)	700	SS-9	15 (83)	1-3-4 N = 7	1.0 B		13				22	
24			698	SS-10	16 (89)	2-3-9 N = 12	1.6 B		15				24	
27			694	SS-11	18 (100)	3-5-5 N = 10	1.5 B		12				27	
29			690	SS-12	18 (100)	3-4-7 N = 11	3.5 B		12				29	
32		Clay LOAM (A-4(2)): Medium stiff, gray, moist, low plastic, with fine to coarse sand, some gravel; (GLACIAL TILL)	688										32	
34			688	SS-13	16 (89)	3-7-8 N = 15	1.3 B		15	22	7		34	
39			682	SS-14	18 (100)	1-3-6 N = 9	2.7 B		12				39	



USER NAME =	rvandermus	DESIGNED	KJA	REVISED	-
CHECKED	MG/ZM	REVISED	-		
PLOT SCALE =	2.0000' / in.	DRAWN	KC	REVISED	-
PLOT DATE =	1/28/2022	CHECKED	KJA	REVISED	-

STATE OF ILLINOIS
 DEPARTMENT OF TRANSPORTATION

BORING LOGS II
 STRUCTURE NO. 099-0192
 SHEET 33 OF 38 SHEETS

F.A.U. RTE.	SECTION	COUNTY	TOTAL SHEETS	SHEET NO.
2688	2020-250-BY	WILL	133	95
ILLINOIS			CONTRACT NO. 62N20	

MODEL: Default
 FILE NAME: p:\pr\primera-pw\ben\key.com\primera-pw\01\Documents\01_P\Projects\2020\200425\00 - IDOT Phase II Various Design\2020\200425\01_WO_1-3 - Wolf Road over I-80\Drawings\Current Drawing Files\CADD_Sheets\Structural\Wolf Road_SHT34_Boringlogs.dgn
 1/28/2022 3:18:09 PM



SOIL BORING LOG

Log of Boring
GC-02
 Sheet 3 of 4

ROUTE:	Federal Aid Urban - 2688	DESCRIPTION:	Wolf Road over I-80
SECTION:	99-5HB-4	DRILLER:	Rubino Engineering, Inc.
COUNTY:	Will	LOGGED BY:	Nikki Kurfman (Gonzalez)
STRUCT. NO.:	099-0192	DRILL RIG TYPE:	Geoprobe 7822DT
STATION & OFFSET:		DRILLING METHOD:	3-1/4" hollow stem auger
SURFACE ELEV.:	721.6 ft	SAMPLING METHOD:	2" Split Spoon
VERTICAL DATUM:	NAVD83	HAMMER TYPE:	Auto Hammer (140 lb)
LAT/LONG:	41.552588, -87.890175	HAMMER EFFICIENCY:	88.8 %
LOCATION:	NE 1/4, SEC. 6, T35N, R12E, 3rd PM	REMARKS:	

Depth (ft)	Material Description	Elevation (ft): 721.6	Sample Number	Recovery, in. (%)	Sampling Resist. Core RQD(%)	Rimac. Qu (tsf)	Pocket Pen. Qu (tsf)	Moisture Content (%)	Dry Unit Weight (pcf)	Liquid Limit	Plasticity Index	Depth (ft)	Remarks
43	Clay LOAM (A-4(2)): Medium stiff, gray, moist, low plastic, with fine to coarse sand, some gravel; (GLACIAL TILL)	678										43	
44		676	SS-15	15 (83)	2-4-11 N = 15	1.6 B		13				44	
45		675										45	
46		675										46	
47		674										47	
48		674										48	
49		672	SS-16	0 (0)	6-12-14 N = 26							49	
50	CLAY: Very stiff, brown, moist to dry, low plastic, with fine to coarse sand, trace gravel; (GLACIAL TILL)	671.6										50	
51		670	SS-17	18 (100)	3-4-8 N = 12	0.7 B		15				51	
52		668										52	
53		668										53	
54		666	SS-18	18 (100)	6-9-14 N = 23	2.9 B		14				54	
55		666										55	
56		664.9										56	
57	CLAY: Stiff, brown, moist, low plastic, with fine to coarse sand, some gravel; (GLACIAL TILL)	664										57	
58		662										58	
59		662	SS-19	17 (95)	7-12-6 N = 18	0.9 B		15				59	
60		660										60	
61		660										61	
62		660										62	



SOIL BORING LOG

Log of Boring
GC-02
 Sheet 4 of 4

ROUTE:	Federal Aid Urban - 2688	DESCRIPTION:	Wolf Road over I-80
SECTION:	99-5HB-4	DRILLER:	Rubino Engineering, Inc.
COUNTY:	Will	LOGGED BY:	Nikki Kurfman (Gonzalez)
STRUCT. NO.:	099-0192	DRILL RIG TYPE:	Geoprobe 7822DT
STATION & OFFSET:		DRILLING METHOD:	3-1/4" hollow stem auger
SURFACE ELEV.:	721.6 ft	SAMPLING METHOD:	2" Split Spoon
VERTICAL DATUM:	NAVD83	HAMMER TYPE:	Auto Hammer (140 lb)
LAT/LONG:	41.552588, -87.890175	HAMMER EFFICIENCY:	88.8 %
LOCATION:	NE 1/4, SEC. 6, T35N, R12E, 3rd PM	REMARKS:	

Depth (ft)	Material Description	Elevation (ft): 721.6	Sample Number	Recovery, in. (%)	Sampling Resist. Core RQD(%)	Rimac. Qu (tsf)	Pocket Pen. Qu (tsf)	Moisture Content (%)	Dry Unit Weight (pcf)	Liquid Limit	Plasticity Index	Depth (ft)	Remarks
64	CLAY: Stiff, brown, moist, low plastic, with fine to coarse sand, some gravel; (GLACIAL TILL)	657.5										64	
65	SAND: Dense, brown, wet, fine- to coarse-grained, with gravel; (GLACIAL TILL)	656.9	SS-20	11 (61)	14-18-20 N = 38			20				65	
66	SILT: Medium stiff, brown, wet, low plastic, some fine sand; (GLACIAL TILL)	656										66	
67		654										67	
68	Silty LOAM: Very stiff, gray, moist, low plastic, with fine sand, some gravel; (GLACIAL TILL)	652	SS-21	18 (100)	6-8-10 N = 18	7.0 B		13				68	
69		652										69	
70		650										70	
71		648										71	
72		647.4	SS-22	18 (100)	8-8-10 N = 18	4.7 B		17				72	
73		646										73	
74	CLAY: Very stiff, gray, dry, low plastic, some fine to coarse sand, some gravel; (GLACIAL TILL)	644										74	
75		642										75	
76		642										76	
77		642										77	
78	SAND: Medium dense, gray, moist, fine- to coarse-grained, with gravel; (GLACIAL TILL)	641.6	SS-23	13 (72)	7-4-8 N = 12			9				78	
79	CLAY: Stiff, gray, moist, low plastic, with fine to coarse sand, some gravel; (GLACIAL TILL)	641.6										79	
80	Boring terminated at 80.0'	640										80	
81		640										81	
82		638										82	
83		638										83	



SOIL BORING LOG

Log of Boring
GC-03
 Sheet 1 of 4

ROUTE:	Federal Aid Urban - 2688	DESCRIPTION:	Wolf Road over I-80
SECTION:	99-5HB-4	DRILLER:	Rubino Engineering, Inc.
COUNTY:	Will	LOGGED BY:	Nikki Kurfman (Gonzalez)
STRUCT. NO.:	099-0192	DRILL RIG TYPE:	Geoprobe 7822DT
STATION & OFFSET:		DRILLING METHOD:	3-1/4" hollow stem auger
SURFACE ELEV.:	721.2 ft	SAMPLING METHOD:	2" Split Spoon
VERTICAL DATUM:	NAVD83	HAMMER TYPE:	Auto Hammer (140 lb)
LAT/LONG:	41.552448, -87.890183	HAMMER EFFICIENCY:	88.8 %
LOCATION:	NE 1/4, SEC. 6, T35N, R12E, 3rd PM	REMARKS:	

Depth (ft)	Material Description	Elevation (ft): 721.2	Sample Number	Recovery, in. (%)	Sampling Resist. Core RQD(%)	Rimac. Qu (tsf)	Pocket Pen. Qu (tsf)	Moisture Content (%)	Dry Unit Weight (pcf)	Liquid Limit	Plasticity Index	Depth (ft)	Remarks
1	CONCRETE	720										1	
2	CRUSHED STONE	718	SS-1	13 (72)	13-10-6 N = 16			7				2	
3		718										3	
4	CLAY: Medium stiff, brown, moist, low plastic, some fine sand; (FILL)	717.2	SS-2	14 (78)	6-6-6 N = 12	1.5 P		18				4	
5		716										5	
6	Clay LOAM (A-4(4)): Medium stiff, gray, moist, low plastic, with fine to coarse sand, some gravel; (GLACIAL TILL)	715.5	SS-3	11 (61)	3-3-4 N = 7	1.6 B		16		25	8	6	
7		714										7	
8		712	SS-4	4 (22)	2-4-7 N = 11	1.8 P		14				8	
9		710										9	
10		710	SS-5	14 (78)	2-2-4 N = 6	1.8 B		15				10	
11		708										11	
12		708	SS-6	17 (95)	3-4-7 N = 11	3.6 B		16				12	
13		706										13	
14		706	SS-7	13 (72)	3-4-6 N = 10	2.5 B		14		24	8	14	
15		704										15	
16		704	SS-8	13 (72)	3-4-8 N = 12	3.9 B		17				16	
17		702										17	
18		702										18	
19		702										19	
20		702										20	



USER NAME =	rvandermus	DESIGNED	KJA	REVISED	-
CHECKED	MG/ZM	REVISED	-		
PLOT SCALE =	2.0000' / in.	DRAWN	KC	REVISED	-
PLOT DATE =	1/28/2022	CHECKED	KJA	REVISED	-

**STATE OF ILLINOIS
 DEPARTMENT OF TRANSPORTATION**

**BORING LOGS III
 STRUCTURE NO. 099-0192**

F.A.U. RTE.	SECTION	COUNTY	TOTAL SHEETS	SHEET NO.
2688	2020-250-BY	WILL	133	96
			CONTRACT NO. 62N20	

SHEET 34 OF 38 SHEETS

ILLINOIS

MODEL: Default
 FILE NAME: p:\w\primera-pw\benley.com\primera-pw\01\Documents\01 Projects\2020\20200425\00 - IDOT Phase II Various Design\20200425_01_WO_1-3 - Wolf Road over I-80\Drawings\Current Drawing Files\CADD_Sheets\Structural\Wolf Road_SHT35_BoringlogsV.dgn
 1/28/2022 3:18:17 PM



SOIL BORING LOG

Log of Boring
GC-04
 Sheet 1 of 4

ROUTE: Federal Aid Urban - 2688 DESCRIPTION: Wolf Road over I-80
 SECTION: 99-5HB-4 DRILLER: Rubino Engineering, Inc. DATE(S) DRILLED: 01/22/2021 to 01/23/2021
 COUNTY: Will DRILLED BY: Joe Kenny LOGGED BY: Nikki Kurfman (Gonzalez)
 STRUCT. NO.: 099-0192 DRILL RIG TYPE: Geoprobe 7822DT BACKFILL: Cuttings and pavement patch
 STATION & OFFSET: DRILLING METHOD: 3-1/4" hollow stem auger Ground Water Observation(s):
 SURFACE ELEV.: 721.7 ft SAMPLING METHOD: 2" Split Spoon First Encounter: 36.00 ft
 VERTICAL DATUM: NAVD83 HAMMER TYPE: Auto Hammer (140 lb) Upon Completion: 31.00 ft - Caved at 46'
 LAT/LONG: 41.552272, -87.890172 HAMMER EFFICIENCY: 88.8 % After Drilling: 24.0 hr after - Filled
 LOCATION: NE 1/4, SEC. 6, T35N, R12E, 3rd PM REMARKS:

Depth (ft)	Material Description	Elevation (ft): 721.7	Sample Number	Recovery, in. (%)	Sampling Resist. Dr. Core ROD(%)	Finnc. Cu. (pcf)	Pocket Pen. Qu (tsf)	Moisture Content (%)	Dry Unit Weight (pcf)	Liquid Limit	Plasticity Index	Depth (ft)	Remarks
1	CONCRETE	720.7										1	
2	CRUSHED STONE	720	SS-1	8 (45)	12-11-10 N = 21							2	
3	CLAY: Stiff, brown, dry, low plastic; (FILL)	718.4										3	
4		716	SS-2	1 (5)	5-7-9 N = 16		15					4	
5	Clay LOAM (A-4(3)): Stiff, gray, dry, low plastic, with fine to coarse sand, trace gravel; (GLACIAL TILL)	716.4										5	
6		716	SS-3	13 (72)	2-4-6 N = 10	1.8 B	16					6	
7		714										7	
8		714	SS-4	14 (78)	2-3-5 N = 8	1.5 B	15			24	8	8	
9		712										9	
10		710	SS-5	15 (83)	2-4-6 N = 10	2.9 B	15					10	
11		708										11	
12		706	SS-6	14 (78)	3-5-8 N = 13	3.3 B	15					12	
13		706										13	
14		704	SS-7	17 (95)	3-4-7 N = 11	3.3 B	14					14	
15		704										15	
16		702	SS-8	18 (100)	3-5-8 N = 13	3.2 P	19					16	
17		702										17	
18												18	
19												19	
20												20	



SOIL BORING LOG

Log of Boring
GC-04
 Sheet 2 of 4

ROUTE: Federal Aid Urban - 2688 DESCRIPTION: Wolf Road over I-80
 SECTION: 99-5HB-4 DRILLER: Rubino Engineering, Inc. DATE(S) DRILLED: 01/22/2021 to 01/23/2021
 COUNTY: Will DRILLED BY: Joe Kenny LOGGED BY: Nikki Kurfman (Gonzalez)
 STRUCT. NO.: 099-0192 DRILL RIG TYPE: Geoprobe 7822DT BACKFILL: Cuttings and pavement patch
 STATION & OFFSET: DRILLING METHOD: 3-1/4" hollow stem auger Ground Water Observation(s):
 SURFACE ELEV.: 721.7 ft SAMPLING METHOD: 2" Split Spoon First Encounter: 36.00 ft
 VERTICAL DATUM: NAVD83 HAMMER TYPE: Auto Hammer (140 lb) Upon Completion: 31.00 ft - Caved at 46'
 LAT/LONG: 41.552272, -87.890172 HAMMER EFFICIENCY: 88.8 % After Drilling: 24.0 hr after - Filled
 LOCATION: NE 1/4, SEC. 6, T35N, R12E, 3rd PM REMARKS:

Depth (ft)	Material Description	Elevation (ft): 721.7	Sample Number	Recovery, in. (%)	Sampling Resist. Dr. Core ROD(%)	Finnc. Cu. (pcf)	Pocket Pen. Qu (tsf)	Moisture Content (%)	Dry Unit Weight (pcf)	Liquid Limit	Plasticity Index	Depth (ft)	Remarks
22	Clay LOAM (A-4(3)): Stiff, gray, dry, low plastic, with fine to coarse sand, trace gravel; (GLACIAL TILL)	698.2	SS-9	18 (100)	5-7-9 N = 16	4.0 B	15					22	
23		698										23	
24		696	SS-10	18 (100)	4-7-9 N = 16	4.4 B	16					24	
25		696										25	
26		696										26	
27	SAND: Loose, gray, dry, fine- to coarse-grained, some gravel; (GLACIAL TILL)	692.2	SS-11	12 (67)	4-9-9 N = 18	1.9 B	14					27	
28		694										28	
29		692.5	SS-12	14 (78)	7-4-5 N = 9	1.6 B	13					29	
30	Clay LOAM: Stiff, gray, moist, low plastic, some fine sand, trace gravel; (GLACIAL TILL)	692										30	
31		690										31	
32		690										32	
33		688	SS-13	0 (0)	5-5-6 N = 11							33	
34		686										34	
35		686										35	
36		684	SS-14	18 (100)	0-3-4 N = 7	1.8 B	16					36	
37		684										37	
38		684										38	
39		682	SS-15	18 (100)	9-7-11 N = 18	2.7 B	16					39	
40		682										40	
41		680										41	



SOIL BORING LOG

Log of Boring
GC-04
 Sheet 3 of 4

ROUTE: Federal Aid Urban - 2688 DESCRIPTION: Wolf Road over I-80
 SECTION: 99-5HB-4 DRILLER: Rubino Engineering, Inc. DATE(S) DRILLED: 01/22/2021 to 01/23/2021
 COUNTY: Will DRILLED BY: Joe Kenny LOGGED BY: Nikki Kurfman (Gonzalez)
 STRUCT. NO.: 099-0192 DRILL RIG TYPE: Geoprobe 7822DT BACKFILL: Cuttings and pavement patch
 STATION & OFFSET: DRILLING METHOD: 3-1/4" hollow stem auger Ground Water Observation(s):
 SURFACE ELEV.: 721.7 ft SAMPLING METHOD: 2" Split Spoon First Encounter: 36.00 ft
 VERTICAL DATUM: NAVD83 HAMMER TYPE: Auto Hammer (140 lb) Upon Completion: 31.00 ft - Caved at 46'
 LAT/LONG: 41.552272, -87.890172 HAMMER EFFICIENCY: 88.8 % After Drilling: 24.0 hr after - Filled
 LOCATION: NE 1/4, SEC. 6, T35N, R12E, 3rd PM REMARKS:

Depth (ft)	Material Description	Elevation (ft): 721.7	Sample Number	Recovery, in. (%)	Sampling Resist. Dr. Core ROD(%)	Finnc. Cu. (pcf)	Pocket Pen. Qu (tsf)	Moisture Content (%)	Dry Unit Weight (pcf)	Liquid Limit	Plasticity Index	Depth (ft)	Remarks
43	Clay LOAM: Stiff, gray, moist, low plastic, some fine sand, trace gravel; (GLACIAL TILL)	678										43	
44		678	SS-16	18 (100)	3-6-8 N = 14	3.6 B	14					44	
45		676										45	
46		676										46	
47		674										47	
48		674										48	
49		672	SS-17	14 (78)	3-6-14 N = 20	3.7 B	14					49	
50		672										50	
51		670										51	
52		670										52	
53		668	SS-18	18 (100)	6-8-10 N = 18	2.5 B	17					53	
54		666										54	
55		666										55	
56		664										56	
57		664										57	
58		662	SS-19	0 (0)	8-7-8 N = 15							58	
59		662										59	
60		660										60	
61		660										61	
62	CLAY (A-6(19)): Stiff, gray, dry, low plastic, trace sand; (GLACIAL TILL)	659.6										62	



USER NAME = rvandermus	DESIGNED KJA	REVISED -
CHECKED MGZM	REVISED -	
PLOT SCALE = 2.0000' / in.	DRAWN KC	REVISED -
PLOT DATE = 1/28/2022	CHECKED KJA	REVISED -

STATE OF ILLINOIS
 DEPARTMENT OF TRANSPORTATION

BORING LOGS V
 STRUCTURE NO. 099-0192
 SHEET 36 OF 38 SHEETS

F.A.U. RTE. 2688	SECTION 2020-250-BY	COUNTY WILL	TOTAL SHEETS 133	SHEET NO. 98
CONTRACT NO. 62N20				
ILLINOIS				

MODEL: Default
 FILE NAME: p:\primeira-pw\ben\key.com\primeira-pw\01\Documents\01 Projects\2020\20200425\00 - IDOT Phase II Various Design\20200425\01_WO 1-3 - Wolf Road over I-80\Drawings\Current Drawing Files\CADD_Sheets\Structural\Wolf Road_SHT38_BoringLogsVII.dgn
 1/28/2022 3:18:24 PM



SOIL BORING LOG

Log of Boring
GC-05
 Sheet 3 of 4

ROUTE:	Federal Aid Urban - 2688	DESCRIPTION:	Wolf Road over I-80
SECTION:	99-5HB-4	DRILLER:	Rubino Engineering, Inc.
COUNTY:	Will	DRILLED BY:	Joe Kenny
STRUCT. NO.:	099-0192	DRILL RIG TYPE:	Geoprobe 7822DT
STATION & OFFSET:		DRILLING METHOD:	3-1/4" hollow stem auger
SURFACE ELEV.:	741.6 ft	SAMPLING METHOD:	2" Split Spoon
VERTICAL DATUM:	NAVD83	HAMMER TYPE:	Auto Hammer (140 lb)
LAT/LONG:	41.551993, -87.890078	HAMMER EFFICIENCY:	88.8 %
LOCATION:	NE 1/4, SEC. 6, T35N, R12E, 3rd PM	REMARKS:	

Depth (ft)	Graphic	Material Description	Elevation (ft): 741.6	Sample Number	Recovery, in. (%)	Sampling Resist. Or Core ROD (%)	Rimac. Cu (pcf)	Pocket Pen. Cu (tsf)	Moisture Content (%)	Dry Unit Weight (pcf)	Liquid Limit	Plasticity Index	Depth (ft)	Remarks
43		Clay LOAM: Stiff, brown, dry, low plastic, some fine sand, trace gravel; (GLACIAL TILL)											43	
44			698	SS-15	18 (100)	5-6-10 N = 16	3.5 B	16					44	
45			696										45	
46			694										46	
47			692										47	
48			690										48	
49		SAND: Loose, gray, wet, fine-grained; (GLACIAL TILL)	688	SS-16	15 (83)	6-8-14 N = 22	2.0 P						49	
50		SILT: Dense, gray, wet, low plastic, some fine sand; (GLACIAL TILL)	686										50	
51		SAND: Medium dense, gray, wet, fine to coarse-grained, some gravel; (GLACIAL TILL)	684										51	
52		Clay LOAM (A-4(3)): Stiff, gray, moist, low plastic, with fine to coarse sand, with gravel; (GLACIAL TILL)	682										52	
53			680										53	
54			678	SS-17	16 (89)	4-7-9 N = 16	3.0 B	14		24	8		54	
55			676										55	
56			674										56	
57			672										57	
58			670										58	
59			668	SS-18	18 (100)	5-7-8 N = 15	1.3 B	14					59	
60			666										60	
61			664										61	
62			662										62	



SOIL BORING LOG

Log of Boring
GC-05
 Sheet 4 of 4

ROUTE:	Federal Aid Urban - 2688	DESCRIPTION:	Wolf Road over I-80
SECTION:	99-5HB-4	DRILLER:	Rubino Engineering, Inc.
COUNTY:	Will	DRILLED BY:	Joe Kenny
STRUCT. NO.:	099-0192	DRILL RIG TYPE:	Geoprobe 7822DT
STATION & OFFSET:		DRILLING METHOD:	3-1/4" hollow stem auger
SURFACE ELEV.:	741.6 ft	SAMPLING METHOD:	2" Split Spoon
VERTICAL DATUM:	NAVD83	HAMMER TYPE:	Auto Hammer (140 lb)
LAT/LONG:	41.551993, -87.890078	HAMMER EFFICIENCY:	88.8 %
LOCATION:	NE 1/4, SEC. 6, T35N, R12E, 3rd PM	REMARKS:	

Depth (ft)	Graphic	Material Description	Elevation (ft): 741.6	Sample Number	Recovery, in. (%)	Sampling Resist. Or Core ROD (%)	Rimac. Cu (pcf)	Pocket Pen. Cu (tsf)	Moisture Content (%)	Dry Unit Weight (pcf)	Liquid Limit	Plasticity Index	Depth (ft)	Remarks
64		Clay LOAM (A-4(3)): Stiff, gray, moist, low plastic, with fine to coarse sand, with gravel; (GLACIAL TILL)	678	SS-19	18 (100)	3-4-6 N = 10	1.2 B	15					64	
65			676										65	
66			674										66	
67			672										67	
68			670										68	
69			668	SS-20	17 (95)	4-7-12 N = 19	3.5 B	15					69	
70			666										70	
71			664										71	
72			662										72	
73			660										73	
74			658	SS-21	16 (89)	6-7-8 N = 15	3.9 B	15					74	
75		CLAY: Medium stiff, gray, wet, low plastic, with fine to coarse sand, some gravel; (GLACIAL TILL)	656										75	
76		Boring terminated at 75.0'	654										76	
77			652										77	
78			650										78	
79			648										79	
80			646										80	
81			644										81	
82			642										82	
83			640										83	



USER NAME =	rvandermus	DESIGNED	KJA	REVISED	-
PLOT SCALE =	2.0000' / in.	CHECKED	MG/ZM	REVISED	-
PLOT DATE =	1/28/2022	DRAWN	KC	REVISED	-
		CHECKED	KJA	REVISED	-

**STATE OF ILLINOIS
 DEPARTMENT OF TRANSPORTATION**

**BORING LOGS VII
 STRUCTURE NO. 099-0192**

SHEET 38 OF 38 SHEETS

F.A.U. RTE.	SECTION	COUNTY	TOTAL SHEETS	SHEET NO.
2688	2020-250-BY	WILL	133	100
CONTRACT NO. 62N20			ILLINOIS	

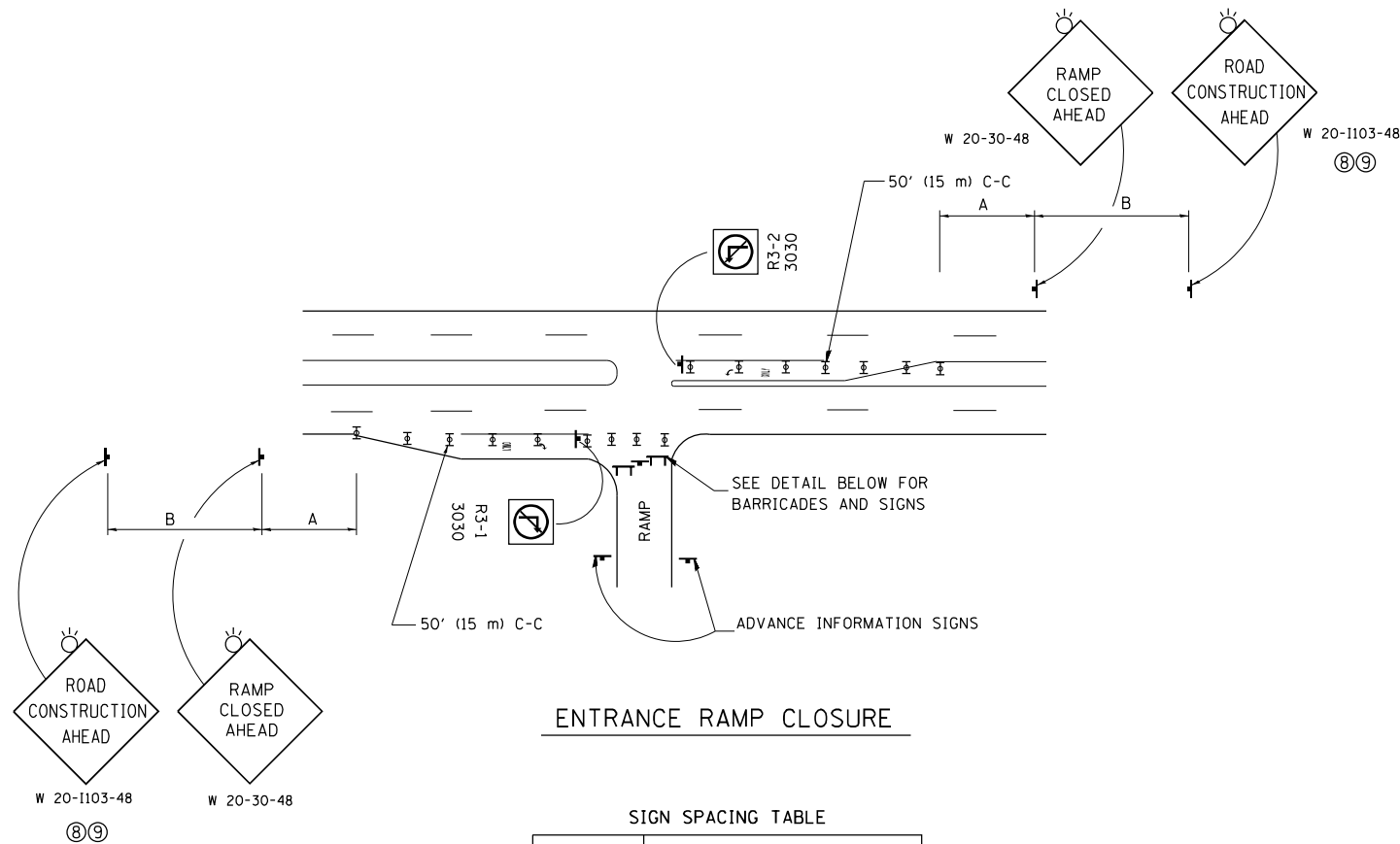

ENTRANCE RAMP CLOSURE

SIGN SPACING TABLE

FACILITY	DISTANCE BETWEEN SIGNS	
	A	B
EXPRESSWAY >24 HOURS	1000' (300 m)	1500' (450 m)
EXPRESSWAY <24 HOURS	500' (150 m)	500' (150 m)
ARTERIAL 55 MPH	500' (150 m)	500' (150 m)
ARTERIAL 50-45 MPH	350' (100 m)	350' (100 m)
ARTERIAL <45 MPH	200' (60 m)	200' (60 m)

DISTANCES MAY BE SHORTENED DEPENDING UPON THE PROXIMITY OF ADJACENT RAMPS OR INTERSECTIONS.

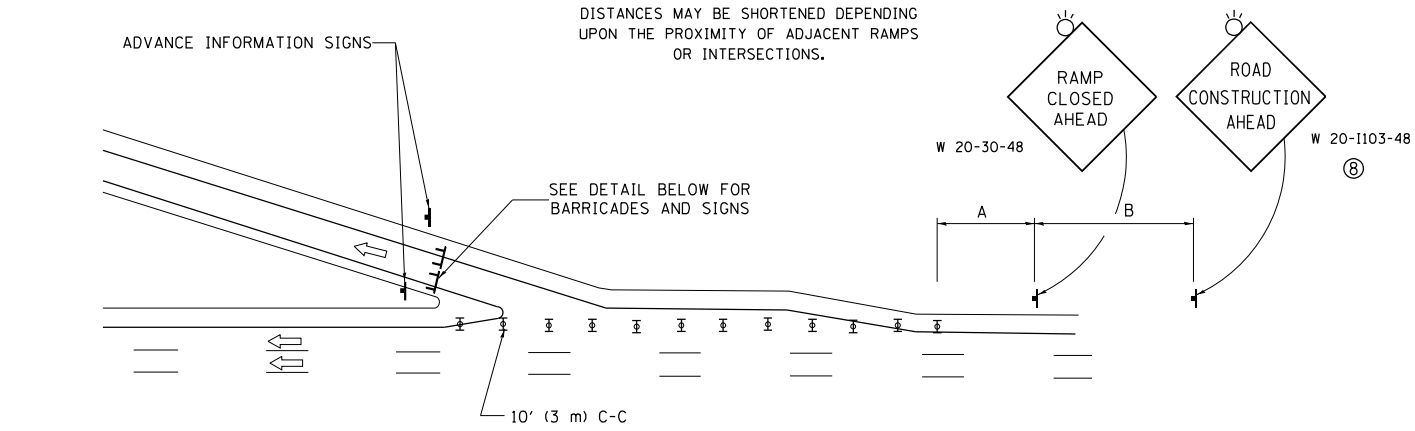

EXIT RAMP CLOSURE

SYMBOLS

- ⊥ TYPE II BARRICADE OR DRUM
- ⊥ TYPE III BARRICADE WITH 2 FLASHING LIGHTS

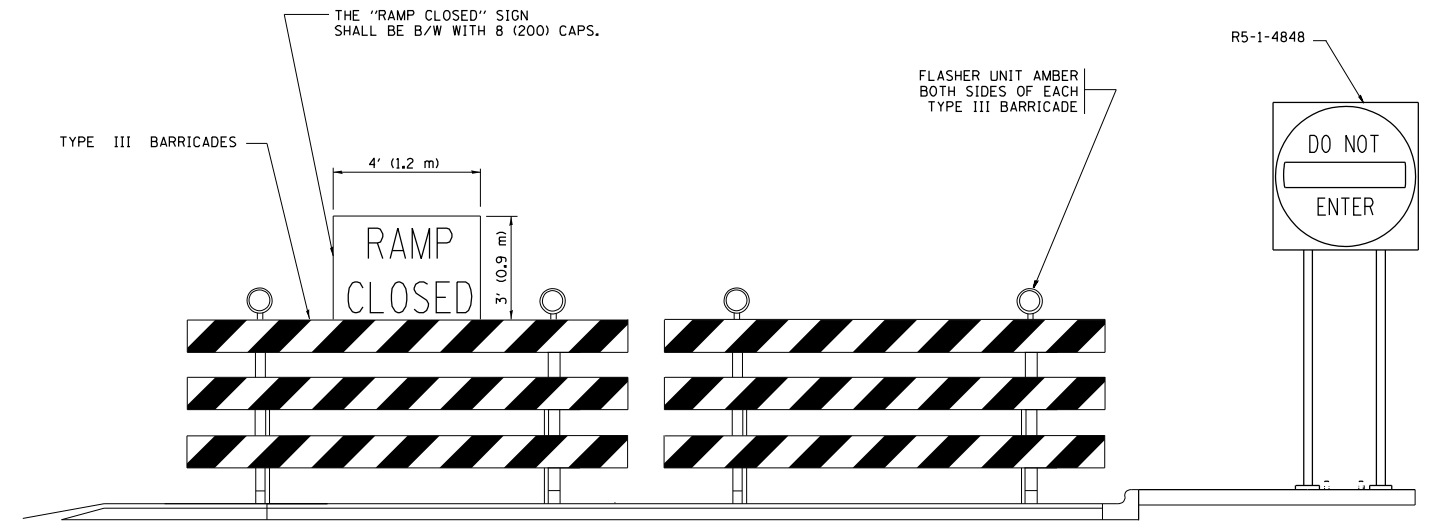

DETAIL FOR REQUIRED BARRICADES & SIGNS

RAMP CLOSURE ADVANCE WARNING SIGN

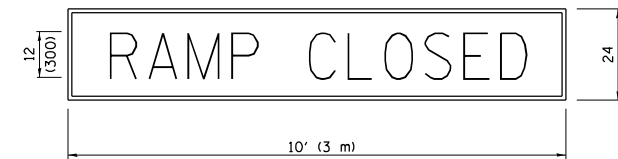

BLACK LEGEND ON ORANGE BACKGROUND MOUNTED DIAGONALLY
E MOD FONT
1 (25) BORDER

THESE SIGNS ARE REQUIRED ON ALL THE EXIT GUIDE SIGNS FOR EXIT RAMPS THAT WILL BE CLOSED FOR MORE THAN FOUR (4) CONSECUTIVE DAYS.

THESE SIGNS ARE REQUIRED ON BOTH SIDES OF THE RAMP, MINIMUM OF 1 WEEK IN ADVANCE OF THE CLOSURE.

THESE SIGNS SHALL BE FABRICATED AND PAID FOR ACCORDING TO THE TEMPORARY INFORMATION SIGNING SPECIAL PROVISION

RAMP CLOSURE ADVANCE INFORMATION SIGN

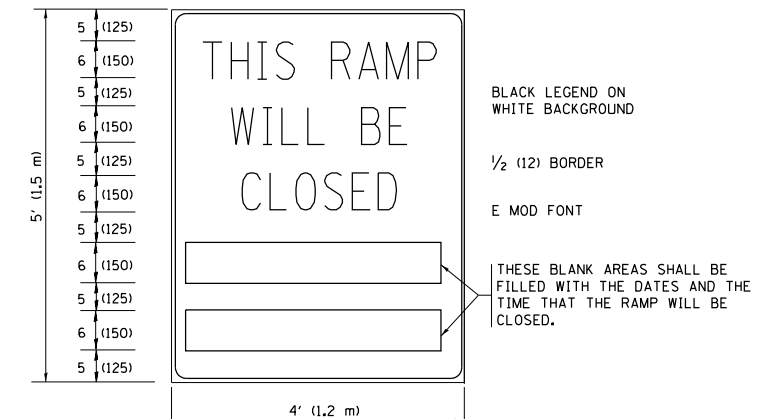

BLACK LEGEND ON WHITE BACKGROUND

1/2 (12) BORDER

E MOD FONT

THESE BLANK AREAS SHALL BE FILLED WITH THE DATES AND THE TIME THAT THE RAMP WILL BE CLOSED.

GENERAL NOTES:

- ① CONES MAY BE SUBSTITUTED FOR DRUMS OR TYPE II BARRICADES DURING DAY OPERATIONS. CONES SHALL BE A MINIMUM OF 28 (700) HIGH.
- ② VERTICAL BARRICADES SHALL NOT BE USED FOR RAMP CLOSURES.
- ③ A FLAGGER SHALL BE POSITIONED AT EACH CLOSED RAMP THAT IS OPEN TO CONSTRUCTION VEHICLES, PRECEDED BY A W20-7 FLAGGER WARNING SIGN.
- ④ ALL ROUTE MARKERS AND TRAILBLAZER ASSEMBLIES WHICH DIRECT MOTORISTS TO A CLOSED ENTRANCE RAMP SHALL BE COVERED WHEN THE RAMP IS CLOSED FOR MORE THAN FOUR (4) DAYS.
- ⑤ THE SIGNING AND BARRICADING WHICH IS REQUIRED BY THIS DETAIL SHALL BE INCLUDED IN THE COST OF TRAFFIC CONTROL AND PROTECTION (EXPRESSWAYS).
- ⑥ AUTHORIZATION FROM THE DISTRICT'S BUREAU OF TRAFFIC IS REQUIRED FOR ALL RAMP CLOSURES.
- ⑦ THE RAMP CLOSURE ADVANCE INFORMATION SIGNS SHALL BE ERECTED IF THE CLOSURE TIME EXCEEDS TWENTY-FOUR (24) HOURS. ADDITIONAL ADVANCE WARNING SIGNS ON EXIT GUIDE SIGNING WILL BE REQUIRED FOR EXIT RAMP CLOSURES THAT EXCEED FOUR (4) DAYS IN LENGTH.
- ⑧ ROAD CONSTRUCTION AHEAD SIGNS MAY BE OMITTED WHEN THIS DETAIL IS USED IN CONJUNCTION WITH OTHER TRAFFIC CONTROL THAT ALREADY INCLUDES A ROAD CONSTRUCTION AHEAD SIGN.
- ⑨ ARTERIAL ROAD CONSTRUCTION AHEAD SIGNS SHALL BE INSTALLED ON THE LEFT SIDE OF TRAFFIC IF THE MEDIAN IS MORE THAN 10 FT WIDE.

ALL DIMENSIONS ARE IN INCHES (MILLIMETERS) UNLESS OTHERWISE SHOWN.

FILE NAME =	USER NAME = footemj	DESIGNED - D.W.S.	REVISED - S.P.B. 01-07
pw:\IL\084EBIDINTEG\illinois.gov\PIWIDOT\Documents\IDOT Offices\District 1\Projects\Dist 1\084EBIDINTEG\CAD\CADsheets\tc08.dgn		CHECKED -	REVISED - S.P.B. 12-09
Default	PLOT SCALE = 50.000' / in.	DATE - 02-83	REVISED - M.D. 06-13
	PLOT DATE = 11/27/2017		REVISED - M.D. 01-18

**STATE OF ILLINOIS
DEPARTMENT OF TRANSPORTATION**

**ENTRANCE AND EXIT RAMP
CLOSURE DETAILS**

SCALE: NONE SHEET 1 OF 1 SHEETS STA. TO STA.

F.A. RTE.	SECTION	COUNTY	TOTAL SHEETS	SHEET NO.
	TC-08			101
ILLINOIS		CONTRACT NO.		

SINGLE LANE WEAVE

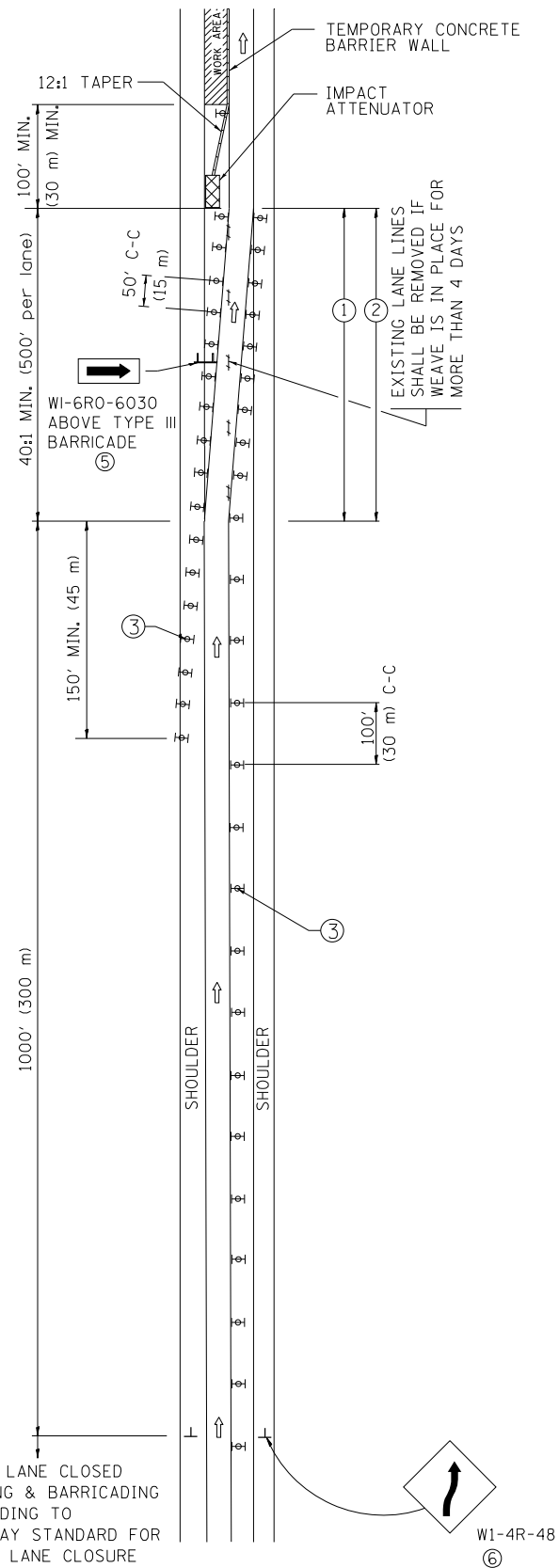

MULTI-LANE WEAVE

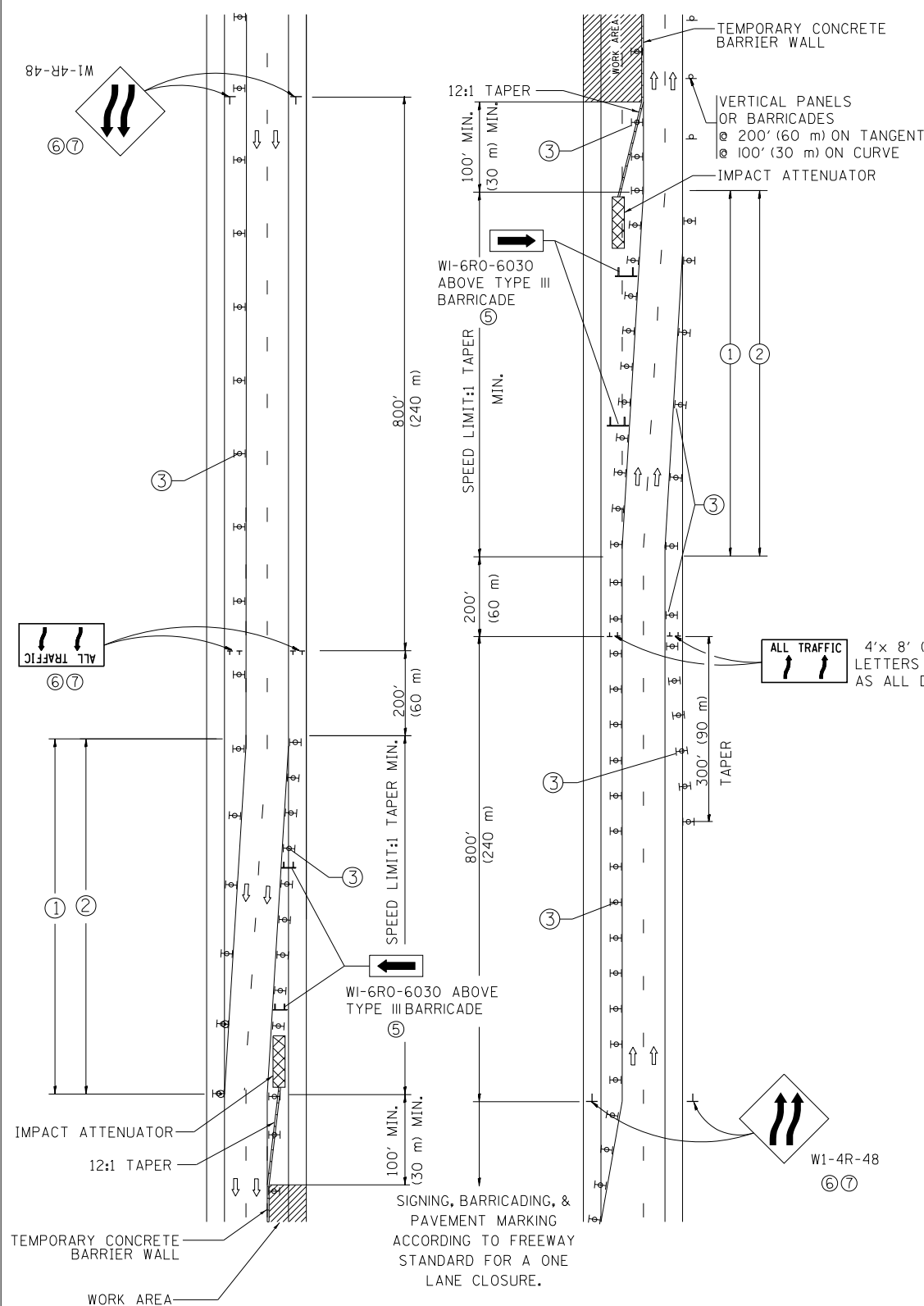

GENERAL NOTES

- ① EXISTING CONFLICTING PAVEMENT MARKING LINES SHALL BE REMOVED. PAVEMENT MARKING REMOVAL SHALL NOT BE REQUIRED FOR SINGLE LANE WEAVES UNDER 4 DAYS IN DURATION.
- ② CONTINUOUS REFLECTIVE TEMPORARY PAVEMENT MARKING TAPE SHALL BE PLACED THROUGHOUT THE TAPER AND FOR 300' (90 m) ALONG SIDE THE WORK AREA WHERE THE CLOSURE TIME IS GREATER THAN FOURTEEN DAYS. THE LEFT EDGE LINE SHALL BE YELLOW AND THE RIGHT EDGE LINE SHALL BE WHITE. FOR MULTI-LANE WEAVES LANE LINES SHALL BE 5 INCH, 10'-30' (3 m-9 m) SKIP DASH, WHITE.
- ③ PLASTIC DRUMS WITH STEADY BURN LIGHTS AT 50' (15 m) C-C SPACING IN TAPERS AND 100' (30 m) C-C SPACING IN TANGENTS.
- ④ ALL SIGNS SHALL BE POST MOUNTED IF THE CLOSURE TIME EXCEEDS FOUR DAYS.
- ⑤ TYPE III BARRICADES MAY BE OMITTED FOR SINGLE-LANE WEAVES UNDER 24-HOURS IN DURATION. W1-6 SIGNS WILL STILL BE REQUIRED. IF THE WIDTH OF OFFSET IS LESS THAN 6' THEN THE TYPE III BARRICADE WITH ATTACHED ARROW SIGN PANEL CAN BE ELIMINATED IN THE TAPER AREAS.
- ⑥ WHEN THE LENGTH OF THE SHIFTED SEGMENT (DISTANCE BETWEEN WEAVE POINTS) IS LESS THAN 1500', DOUBLE REVERSE CURVE SIGNS (W24-1) SHOULD BE USED INSTEAD OF THE REVERSE CURVE (W1-4) SIGNS. ARROWS ON THE 4'X8' "ALL TRAFFIC" SIGNS SHALL BE THE SAME SHAPE.
- ⑦ THE NUMBER OF ARROWS ON THESE SIGNS SHALL MATCH THE NUMBER OF LANES OPEN TO TRAFFIC.

SYMBOLS

- DIRECTION OF TRAFFIC
- WORK AREA
- SIGN ON PORTABLE OR PERMANENT SUPPORT
- TYPE II BARRICADE OR DRUM WITH MONO-DIRECTIONAL STEADY BURNING LIGHT
- TEMPORARY CONCRETE BARRIER WALL
- IMPACT ATTENUATOR
- W1-4R-48
⑥
- W24-1-48
⑦

ALL DIMENSIONS ARE IN INCHES (MILLIMETERS) UNLESS OTHERWISE SHOWN

FILE NAME =	USER NAME = footemj	DESIGNED - DWS	REVISED - JAF 02-06	STATE OF ILLINOIS DEPARTMENT OF TRANSPORTATION	TRAFFIC CONTROL DETAILS FOR FREEWAY SINGLE & MULTI-LANE WEAVE	F.A. RTE.	SECTION	COUNTY	TOTAL SHEETS	SHEET NO.
ct:\pw\work\p\dot\footemj\d0108315\tc09.dgn	DRAWN -	REVISED - SPB 01-07	2688			2020-250-BY	COOK & WILL	133	102	
PLOT SCALE = 50.000' / in.	CHECKED -	REVISED - SPB 12-09	TC-09			CONTRACT NO.				
PLOT DATE = 7/1/2013	DATE - 02-87	REVISED - MD 06-13	SCALE: NONE			SHEET NO. 1 OF 1 SHEETS	STA. TO STA.	FED. ROAD DIST. NO. 1 ILLINOIS FED. AID PROJECT		

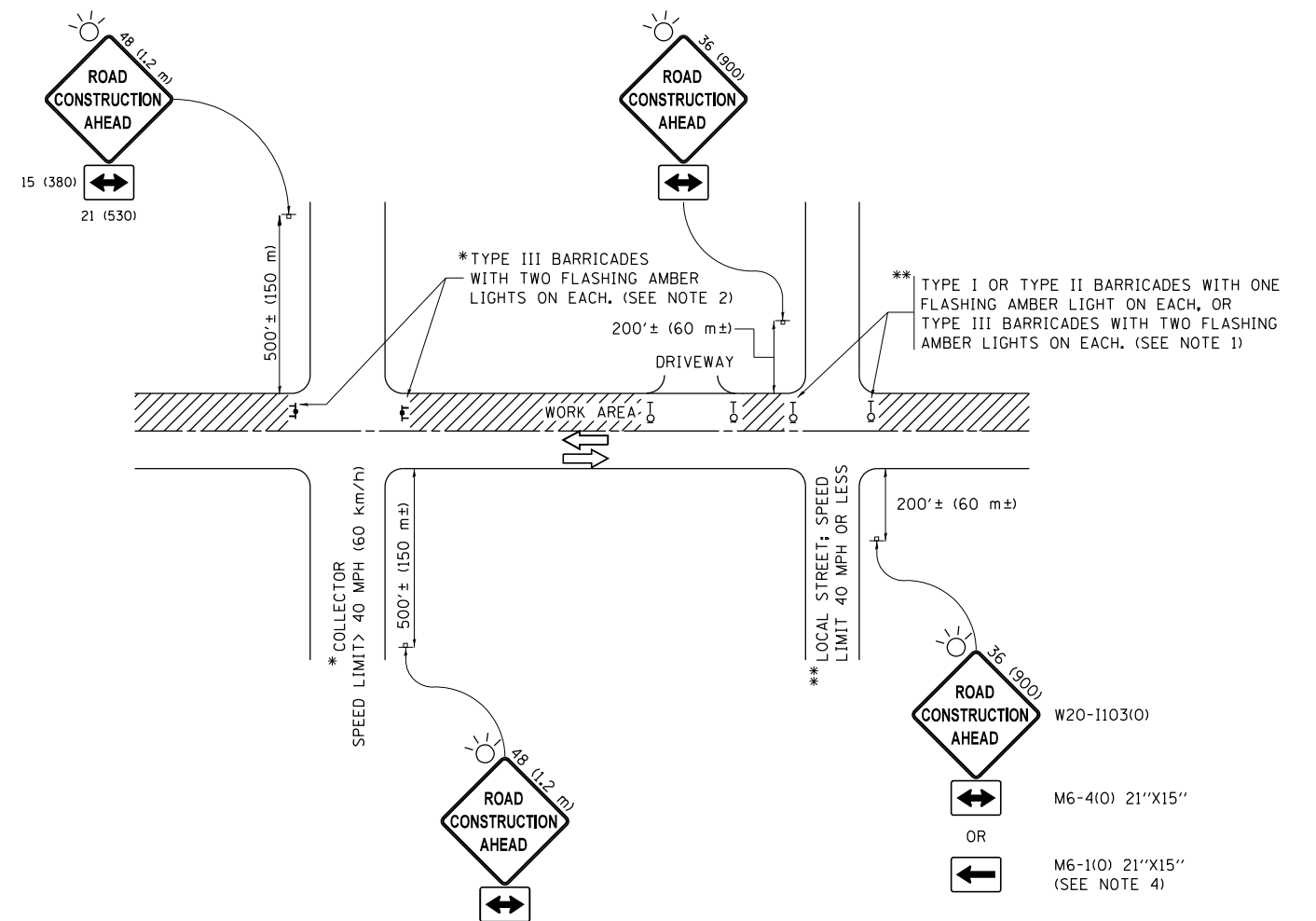

NOTES:

1. SIDE ROAD WITH A SPEED LIMIT OF 40 MPH (60 km/h) OR LESS AS SHOWN ON THE DRAWING AND AS DIRECTED BY THE ENGINEER:
 - a) ONE "ROAD CONSTRUCTION AHEAD" SIGN 36 x 36 (900x900) WITH A FLASHER MOUNTED ON IT APPROXIMATELY 200' (60 m) IN ADVANCE OF THE MAIN ROUTE.
 - b) THE CLOSED PORTION OF THE MAIN ROUTE SHALL BE PROTECTED BY BLOCKING WITH TYPE I, TYPE II OR TYPE III BARRICADES, 1/3 OF THE CROSS SECTION OF THE CLOSED PORTION.
2. SIDE ROAD WITH A SPEED LIMIT GREATER THAN 40 MPH (60 km/h) AS SHOWN ON THE DRAWING AND AS DIRECTED BY THE ENGINEER:
 - a) ONE "ROAD CONSTRUCTION AHEAD" SIGN 48 x 48 (1.2 m x 1.2 m) WITH A FLASHER MOUNTED ON IT APPROXIMATELY 500' (150 m) IN ADVANCE OF THE MAIN ROUTE.
 - b) THE CLOSED PORTION OF THE MAIN ROUTE SHALL BE PROTECTED BY BLOCKING WITH TYPE III BARRICADES, 1/2 OF THE CROSS SECTION OF THE CLOSED PORTION.
3. CONES MAY BE SUBSTITUTED FOR BARRICADES OR DRUMS AT HALF THE SPACING DURING DAY OPERATIONS. CONES SHALL BE A MINIMUM OF 28 (710) IN HEIGHT.
4. WHEN THE SIDE ROAD LIES BETWEEN THE BEGINNING OF THE MAINLINE SIGNING AND THE WORK ZONE, A SINGLE HEADED ARROW (M6-1) SHALL BE USED IN LIEU OF THE DOUBLE HEADED ARROW (M6-4).
5. WHEN WORK IS BEING PERFORMED ON A SIDE ROAD OR DRIVEWAY, FOLLOW THE APPLICABLE STANDARD(S). THE DIRECTIONAL ARROW (M6-1 OR M6-4) SHALL BE COVERED OR REMOVED WHEN NO LONGER CONSISTENT WITH THE TRAFFIC CONTROL SET-UP.
6. ADVANCE WARNING SIGNS ARE TO BE OMITTED ON DRIVEWAYS UNLESS OTHERWISE SPECIFIED IN THE PLANS OR BY THE ENGINEER.
7. THE TRAFFIC CONTROL AND PROTECTION FOR SIDE ROADS, INTERSECTIONS, AND DRIVEWAYS SHALL BE INCLUDED IN THE COST OF SPECIFIED TRAFFIC CONTROL STANDARDS OR ITEMS.

All dimensions are in inches (millimeters) unless otherwise shown.

FILE NAME =	USER NAME = footemj	DESIGNED - L.H.A.	REVISED - A. HOUSEH 10-15-96
p:\11084EBIDINTEG\illinois.gov\PWIDOT\Documents\IDOT Offices\District 1\Projects\Dist 1\11084EBIDINTEG\CADD\cadd\cadsheets\tc10.dgn			REVISED - T. RAMMACHER 01-06-00
Default	PLOT SCALE = 50.000' / in.	CHECKED -	REVISED - A. SCHUETZE 07-01-13
	PLOT DATE = 9/15/2016	DATE - 06-89	REVISED - A. SCHUETZE 09-15-16

**STATE OF ILLINOIS
DEPARTMENT OF TRANSPORTATION**

**TRAFFIC CONTROL AND PROTECTION FOR
SIDE ROADS, INTERSECTIONS, AND DRIVEWAYS**

SCALE: NONE SHEET 1 OF 1 SHEETS STA. TO STA.

F.A. RTE.	SECTION	COUNTY	TOTAL SHEETS	SHEET NO.
2688	2020-250-BY	COOK & WILL	133	103
TC-10			CONTRACT NO.	
ILLINOIS FED. AID PROJECT				

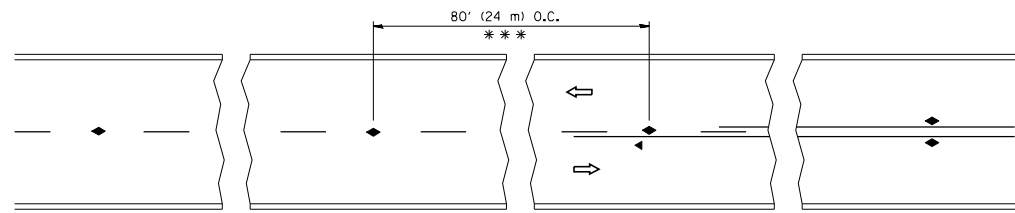

*** REDUCE TO 40' (12 m) O.C. ON CURVES WITH POSTED OR ADVISORY SPEED 45 M.P.H. (70 km/h) OR LESS.

TWO-LANE/TWO-WAY

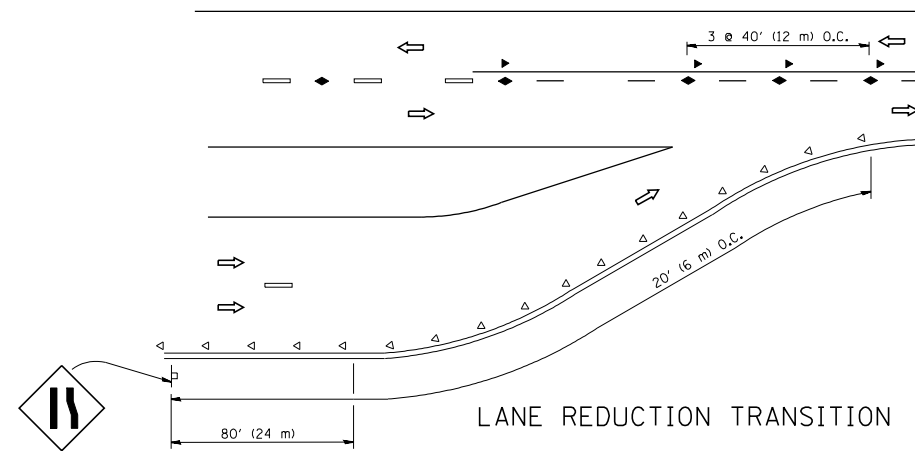

LANE REDUCTION TRANSITION

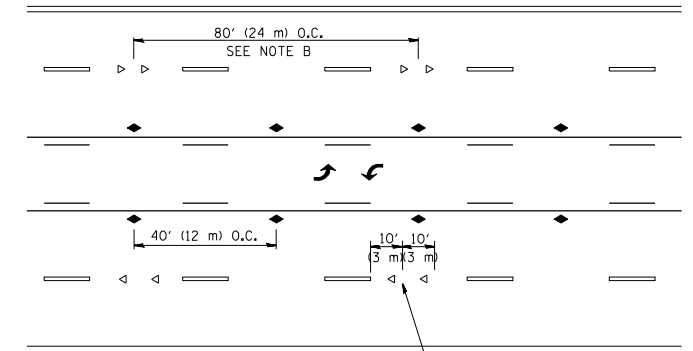

TWO-WAY LEFT TURN

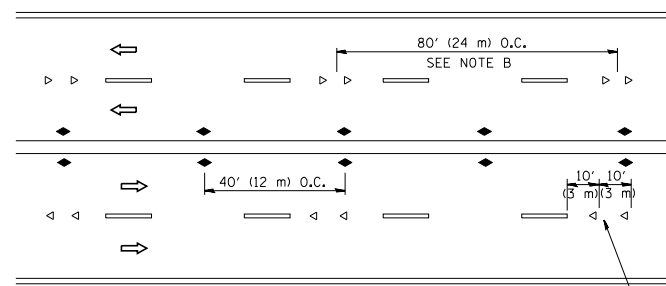

MULTI-LANE/UNDIVIDED

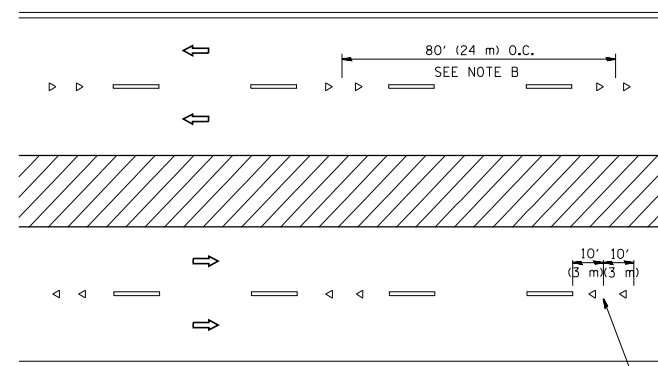

MULTI-LANE/DIVIDED

GENERAL NOTES

1. MARKERS USED WITH DASHED LINES SHALL BE CENTERED IN THE GAP BETWEEN SEGMENTS.
2. MARKERS USED ADJACENT TO SOLID LINES SHALL BE OFFSET 2 TO 3 (50 TO 75) TOWARD TRAFFIC AS SHOWN.
3. MARKERS THROUGH TANGENTS LESS THAN 500' (150 m) IN LENGTH BETWEEN CURVES SHALL BE INSTALLED AT THE LESSER OF THE TWO CURVE SPACINGS.

SYMBOLS

- YELLOW STRIPE
- WHITE STRIPE
- ◀ ONE-WAY AMBER MARKER
- ◁ ONE-WAY CRYSTAL MARKER (W/O)
- ◆ TWO-WAY AMBER MARKER

LANE MARKER NOTES

- A. USE DOUBLE LANE LINE MARKERS SPACED AS SHOWN.
- B. REDUCE TO 40' (12 m) O.C. ON CURVES WHERE ADVISORY SPEEDS ARE 10 M.P.H (20 km/h) LOWER THAN POSTED SPEEDS.

DESIGN NOTES

1. DOUBLE LANE LINE MARKERS SHALL BE USED UNLESS SPECIFIED OTHERWISE.
2. EXCEPT AS SHOWN ON THE LANE REDUCTION TRANSITION AND FREEWAY EXIT RAMP DETAIL, MARKERS ARE NOT TO BE SPECIFIED ON RIGHT EDGE LINES.
3. THE EXACT MARKER LIMITS, SPACING, AND COLOR SHALL BE INCLUDED IN THE PLANS WHEN STANDARD SPECIFICATIONS ARE NOT BEING USED.
4. MARKERS SHOULD NOT BE USED ALONGSIDE CURBS EXCEPT FOR EXTREMELY SHORT SECTIONS OF CURBS WHERE NOT MORE THAN TWO MARKERS WOULD BE INVOLVED.

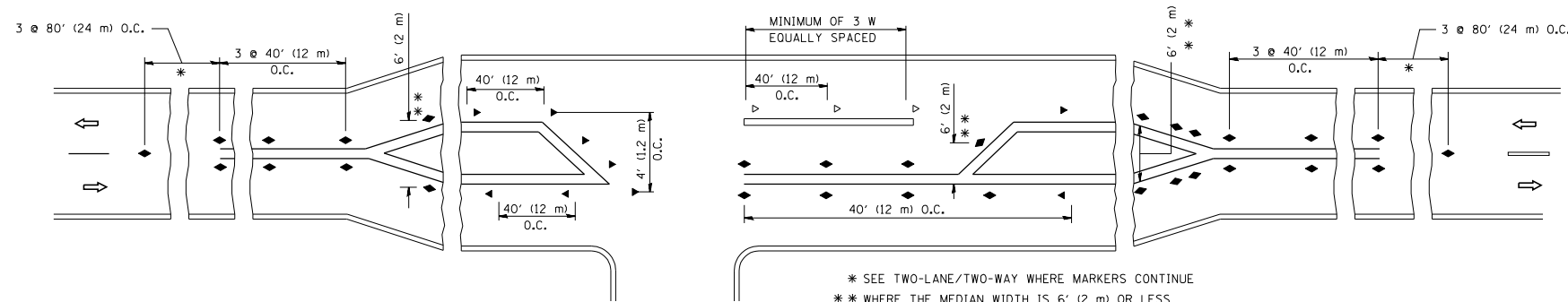

LEFT TURN

* SEE TWO-LANE/TWO-WAY WHERE MARKERS CONTINUE
 ** WHERE THE MEDIAN WIDTH IS 6' (2 m) OR LESS USE TWO-WAY MARKERS.

All dimensions are in inches (millimeters) unless otherwise shown.

FILE NAME =	USER NAME = lryso	DESIGNED -	REVISED - T. RAMMACHER 09-19-94
ct:\pw\work\pwidot\lryso\d0108315\te11.dgn		DRAWN -	REVISED - T. RAMMACHER 03-12-99
	PLOT SCALE = 50.000' / IN.	CHECKED -	REVISED - T. RAMMACHER 01-06-00
	PLOT DATE = 3/2/2011	DATE -	REVISED - C. JUCIUS 09-09-09

STATE OF ILLINOIS
 DEPARTMENT OF TRANSPORTATION

TYPICAL APPLICATIONS
 RAISED REFLECTIVE PAVEMENT MARKERS (SNOW-PLOW RESISTANT)

SCALE: NONE SHEET NO. 1 OF 1 SHEETS STA. TO STA.

F.A. RTE.	SECTION	COUNTY	TOTAL SHEETS	SHEET NO.
2688	2020-250-BY	COOK & WILL	133	104
TC-11		CONTRACT NO.		
FED. ROAD DIST. NO. 1 ILLINOIS FED. AID PROJECT				

TURN BAY ENTRANCE AT START OF LANE CLOSURE TAPER

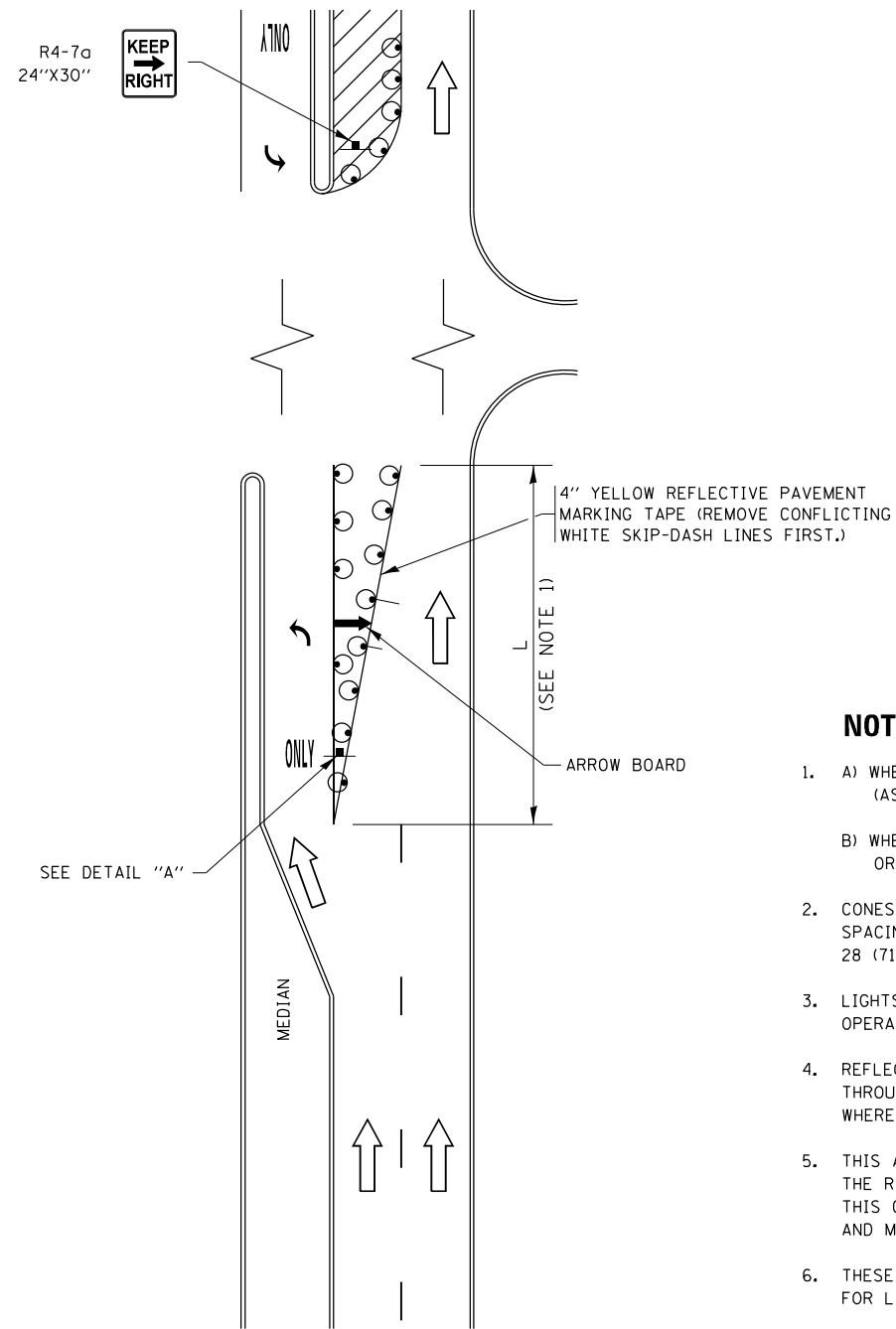

FIGURE 1

TURN BAY ENTRANCE WITHIN A LANE CLOSURE

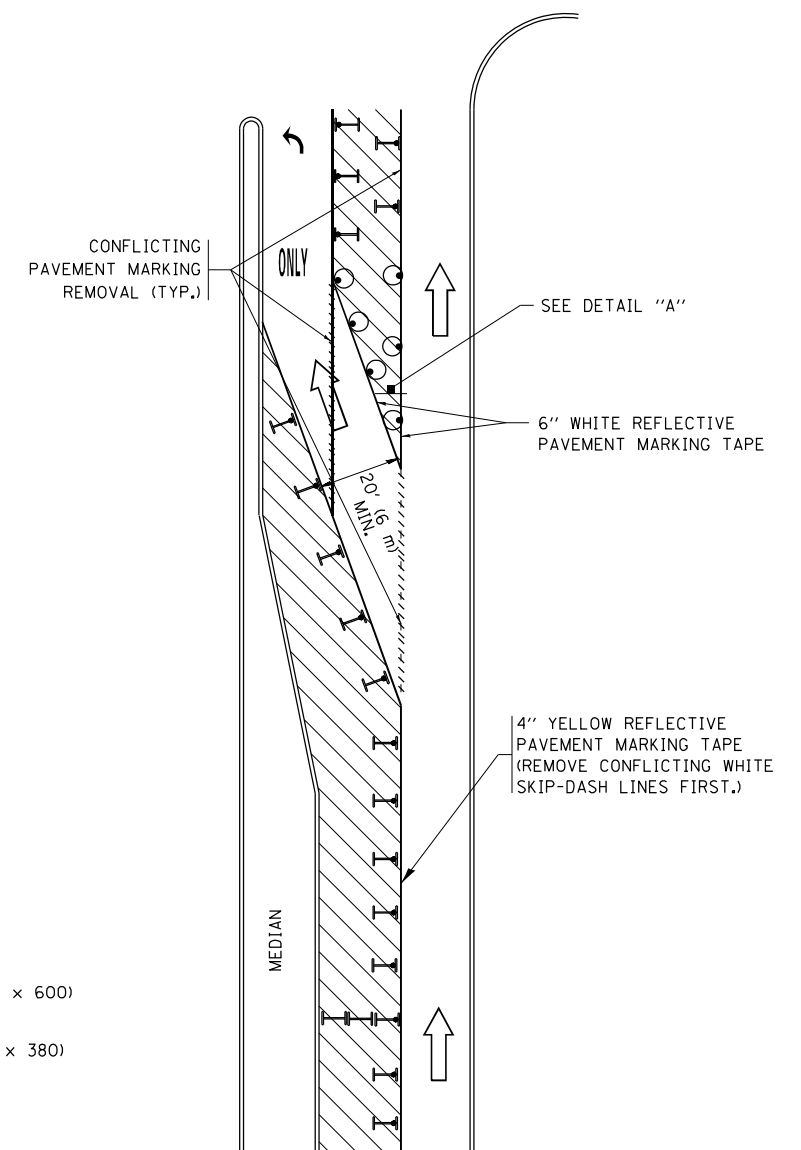

FIGURE 2

LEGEND

- WORK AREA
- LANE OPEN TO TRAFFIC
- ARROW BOARD
- TYPE I OR II BARRICADE OR DRUM WITH STEADY BURN LIGHT
- DRUM WITH STEADY BURN LIGHT
- SIGN ASSEMBLY
- TYPE I OR II CHECK BARRICADE WITH FLASHING LIGHT

NOTES:

1. A) WHEN "L" IS \leq THE STORAGE LENGTH OF THE TURN LANE (AS SHOWN IN FIG. 1), USE FIGURE 1.
B) WHEN "L" IS $>$ THE STORAGE LENGTH OF THE TURN LANE OR THE TURN LANE IS WITHIN THE LANE CLOSURE, USE FIGURE 2.
2. CONES MAY BE SUBSTITUTED FOR BARRICADES OR DRUMS AT HALF THE SPACING DURING DAY OPERATIONS. CONES SHALL BE A MINIMUM OF 28 (710) IN HEIGHT.
3. LIGHTS WILL NOT BE REQUIRED ON BARRICADES OR DRUMS FOR DAY OPERATIONS. ALL LIGHTS SHALL BE MONODIRECTIONAL.
4. REFLECTIVE TEMPORARY PAVEMENT MARKINGS SHALL BE PLACED THROUGHOUT THE BARRICADED AREAS OF EACH TURN BAY AS SHOWN WHERE THE CLOSURE TIME IS GREATER THAN FOURTEEN (14) DAYS.
5. THIS APPLICATION ALSO APPLIES WHEN WORK IS BEING PERFORMED IN THE RIGHT LANE(S) AND THE RIGHT TURN BAY IS TO REMAIN OPEN. UNDER THIS CONDITION, "RIGHT TURN LANE" R3-I100R 24 x 24 (600 x 600) AND M6-2R 21 x 15 (530 x 380) SHALL BE USED.
6. THESE CONTROLS SHALL SUPPLEMENT MAINLINE TRAFFIC CONTROL FOR LANE CLOSURES.
7. THE SIGNS SHALL BE MOUNTED ABOVE THE BARRICADES/DRUMS ON SEPARATE SIGN SUPPORTS THAT MEET NCHRP 350 OR MASH PREQUIREMENTS.
8. TRAFFIC CONTROL AND PROTECTION AT TURN BAYS (TO REMAIN OPEN TO TRAFFIC) SHALL BE INCLUDED IN THE COST OF SPECIFIED TRAFFIC CONTROL STANDARDS OR ITEMS.

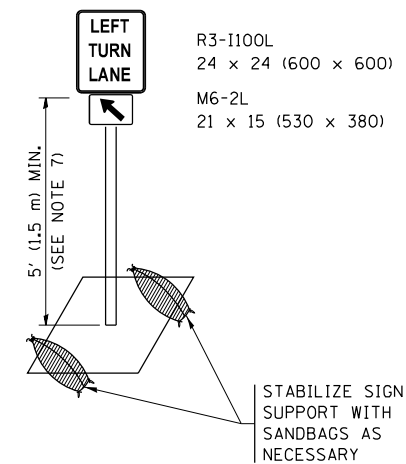

DETAIL A

All dimensions are in inches (millimeters) unless otherwise shown.

FILE NAME =	USER NAME = footemj	REVISED - T. RAMMACHER 09-08-94	REVISED - R. BORO 09-14-09	STATE OF ILLINOIS DEPARTMENT OF TRANSPORTATION	TRAFFIC CONTROL AND PROTECTION AT TURN BAYS (TO REMAIN OPEN TO TRAFFIC)			F.A. RTE.	SECTION	COUNTY	TOTAL SHEETS	SHEET NO.	
pw:\IL\084EBIDINTEG\Illinois.gov\PIDOT\Documents\IDOT Offices\District 1\Projects\Dist 1\ADDData\CAHOUSEH\10-07-95	REVISED - A. SCHUETZE 07-01-13	REVISED - A. HOUSEH 10-12-96	REVISED - A. SCHUETZE 09-15-16					2688	2020-250-BY	COOK & WILL	133	106	
Default	PLOT SCALE = 50.0000' / in.	REVISED - T. RAMMACHER 01-06-00	REVISED -					TC-14			CONTRACT NO.		
	PLOT DATE = 9/15/2016			SCALE: NONE			SHEET 1 OF 1 SHEETS			STA. TO STA.		ILLINOIS FED. AID PROJECT	

PARTIAL RAMP CLOSURE DETAILS

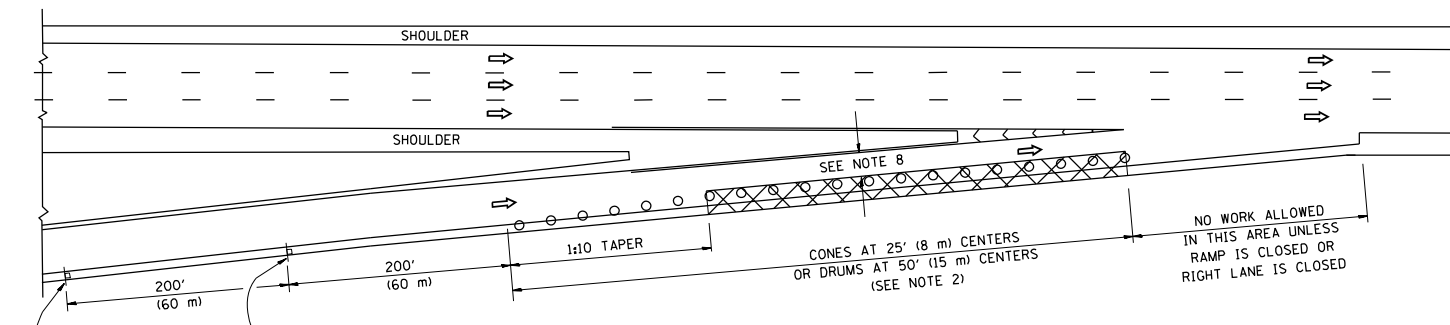

TYPICAL ENTRANCE RAMP

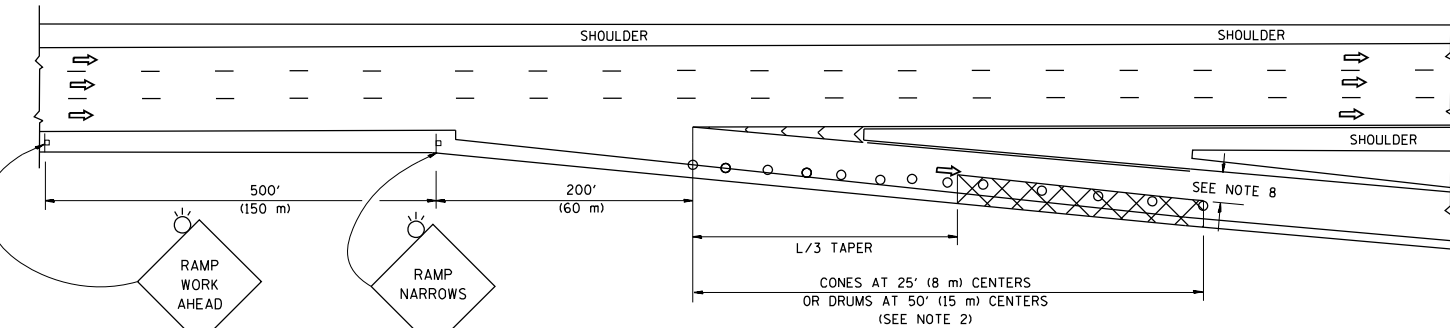

TYPICAL EXIT RAMP

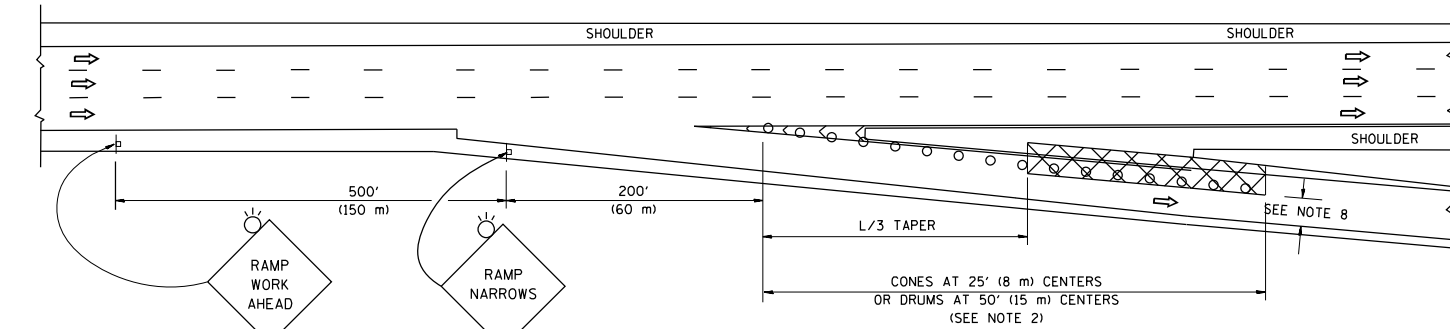

TYPICAL EXIT RAMP

SYMBOLS

- ACTIVE WORK AREA
- SIGN ON PORTABLE OR PERMANENT SUPPORT
- FLAGGER WITH CONTROL SIGN
- TYPE II BARRICADE OR DRUM
- CONE, DRUM OR BARRICADE
- IMPACT ATTENUATOR OF TYPE AND TEST LEVEL SPECIFIED

GENERAL NOTES

1. THE "L" DISTANCE EQUALS:

SPEED LIMIT	FORMULAS
45 mph (80 km/h)	METRIC ENGLISH
OR GREATER:	$L=0.65(W)(S)$ $L=(W)(S)$

W = WIDTH OF OFFSET IN FEET (METERS)
 S = NORMAL POSTED SPEED MPH (KM/H)
2. TYPE II BARRICADES OR DRUMS ARE REQUIRED FOR ALL NIGHTTIME CLOSURES. TYPE II BARRICADES OR DRUMS WITH MONODIRECTIONAL STEADY BURN LIGHTS ARE REQUIRED FOR DELINEATING OBSTACLES, EXCAVATIONS, OR HAZARDS EXCEEDING 100 FT (30m) IN LENGTH AT NIGHT.
3. ALL SIGNS SHALL BE POST MOUNTED IF THE CLOSURE TIME EXCEEDS FOUR DAYS.
4. FLASHING LIGHTS SHALL BE USED DURING THE HOURS OF DARKNESS AND SHALL BE INSTALLED ABOVE THE FIRST TWO SETS OF SIGNS.
5. THE IMPACT ATTENUATOR, TEMPORARY IS NOT REQUIRED WHEN THE TEMPORARY CONCRETE BARRIER WALL IS PROTECTED BY OR IS TIED INTO THE EXISTING GUARDRAIL. IF OFFSET IS LESS THAN 5 FEET USE NARROW USE TYPE DEVICE TO MEET NCHRP350/MASH.
6. AUTHORIZATION FROM THE DISTRICT'S BUREAU OF TRAFFIC IS REQUIRED FOR ALL FREEWAY CLOSURES.
7. THE FLAGGER AND FLAGGER SIGN ARE REQUIRED AT THE ABOVE WORK SITES WHEN:
 - a. FOUR OR MORE WORK VEHICLES ENTER THE TRAFFIC LANES IN A ONE HOUR PERIOD.
 - b. THE WORK AVTIVITY REQUIRES FREQUENT ENCROACHMENT INTO THE LANE OPEN TO TRAFFIC.
 THE FLAGGER SHALL BE STATIONED APPROXIMATELY 100' (30 m) TO 200' (60 m) IN ADVANCE OF THE WORKERS.
8. 12' MIN. WIDTH TANGENT SECTION
 16' MIN. WIDTH CURVE SECTION.

SHOULDER CLOSURE DETAILS

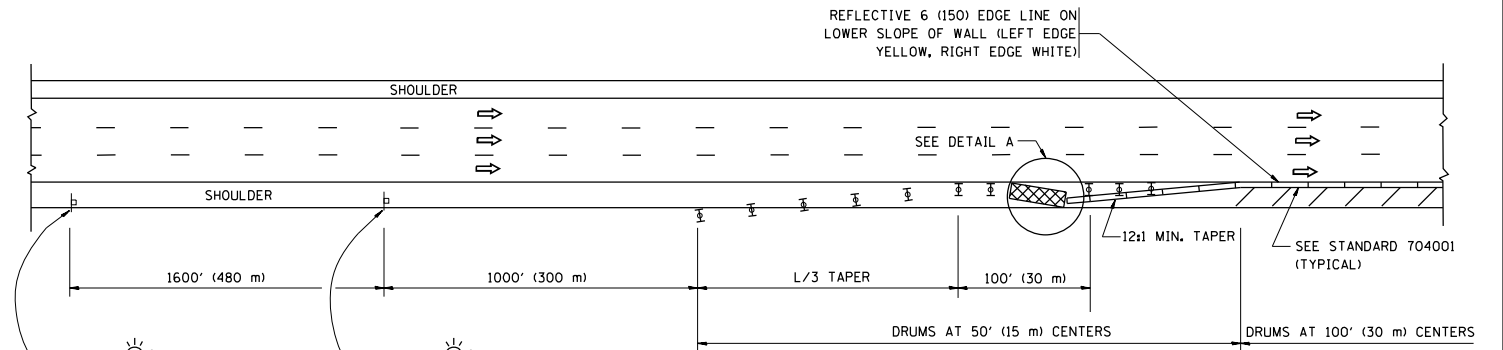

PERMANENT SHOULDER CLOSURE

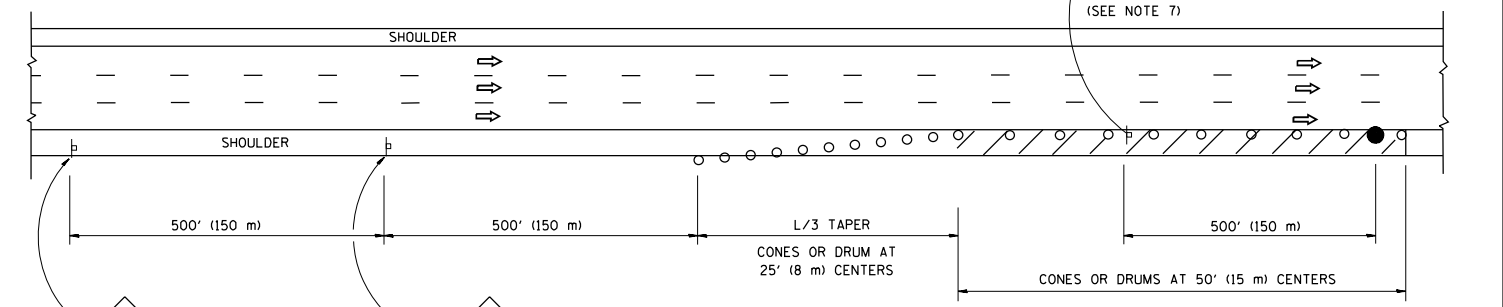

DAYTIME SHOULDER CLOSURE

THIS DETAIL IS USED WHERE:
 1. VEHICLES, EQUIPMENT, WORKERS OR THEIR ACTIVITIES ENCROACH IN AN AREA CLOSER THAN 15' (4.5 m) TO THE EDGE OF PAVEMENT FOR A PERIOD IN EXCESS OF 15 MINUTES.

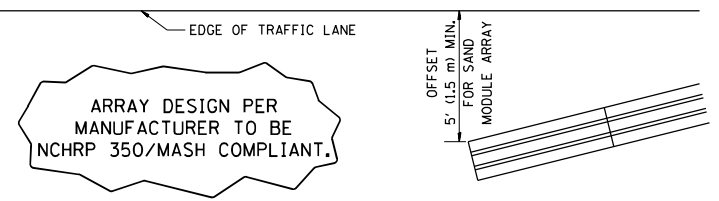

DETAIL "A"
 IMPACT ATTENUATOR, TEMPORARY
 (SEE NOTE 5)

ALL DIMENSIONS ARE IN INCHES (MILLIMETERS) UNLESS OTHERWISE SHOWN.

FILE NAME =	USER NAME = footemj	DESIGNED -	REVISED - S.P.B. 01-07
pw:\IL\084EBID\INTEG\11\inois.gov\PI\DOT\Documents\IDOT Offices\District 1\Projects\Dist 1\084EBID\CAD\Drawings\17.dgn		CHECKED -	REVISED - S.P.B. 12-09
Default	PLOT SCALE = 50.0000' / in.	DATE - 11-96	REVISED - M.D. 06-13
	PLOT DATE = 11/27/2017		REVISED - M.D. 01-18

STATE OF ILLINOIS
 DEPARTMENT OF TRANSPORTATION

TRAFFIC CONTROL DETAILS FOR FREEWAY
 SHOULDER CLOSURES AND PARTIAL RAMP CLOSURES

SCALE: NONE SHEET 1 OF 1 SHEETS STA. TO STA.

F.A. RTE.	SECTION	COUNTY	TOTAL SHEETS	SHEET NO.
2688	2020-250-BY	COOK & WILL	133	107
TC-17		CONTRACT NO.		
ILLINOIS FED. AID PROJECT				

SIGNING FOR FLAGGING OPERATIONS AT WORK ZONE OPENINGS

WORK ZONE EXIT OPENING

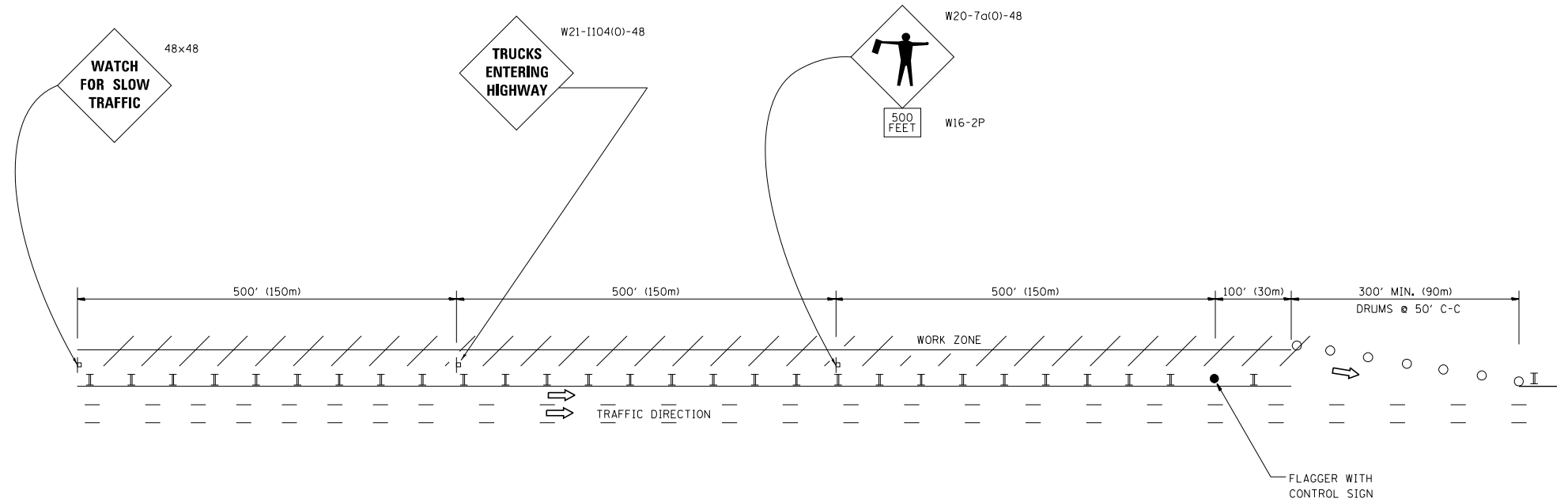

WORK ZONE ENTRY OPENING

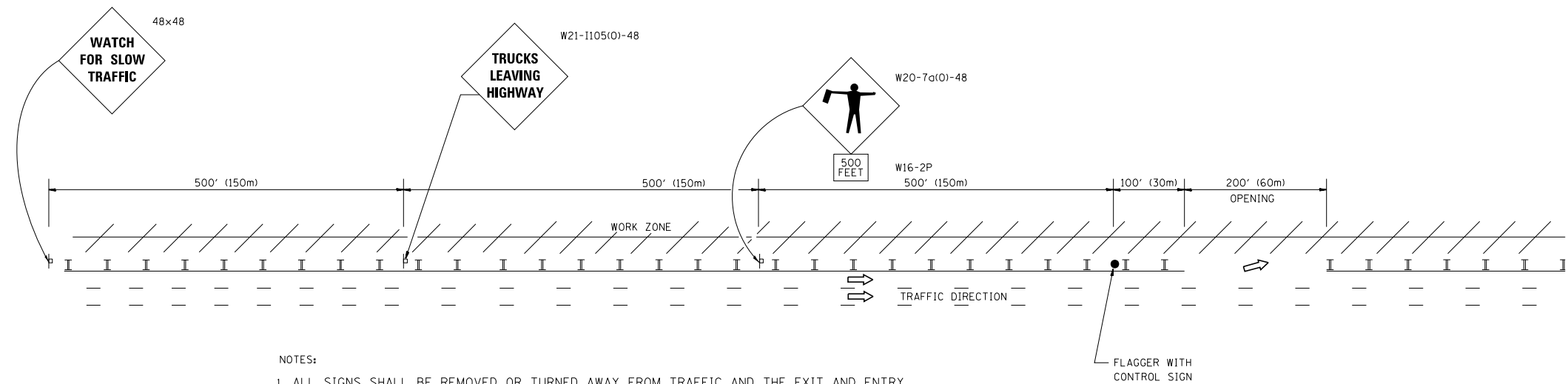

NOTES:

1. ALL SIGNS SHALL BE REMOVED OR TURNED AWAY FROM TRAFFIC AND THE EXIT AND ENTRY OPENINGS SHALL BE CLOSED WHEN THE FLAGGING OPERATION CEASES. NON OPERATING EQUIPMENT SHALL COMPLY WITH ARTICLE 701.11
2. WORK ZONE OPENINGS SHALL BE A MINIMUM OF ONE HALF MILE APART AND A MINIMUM OF ONE QUARTER MILE FROM ALL ENTRANCE AND EXIT RAMPS.
3. EXITING THE WORK ZONE AT ANY PLACE OTHER THAN AT A WORK ZONE EXIT OPENING WILL BE PROHIBITED.
4. ALL VEHICLES SHALL ENTER THE WORK ZONE AT ENTRY OPENINGS, USING THEIR TURN SIGNALS TO WARN MOTORISTS
5. FLAGGERS SHALL NOT STOP TRAFFIC OR DIRECT TRAFFIC INTO AN ADJACENT LANE.

ALL DIMENSIONS ARE IN INCHES (MILLIMETERS) UNLESS OTHERWISE SHOWN

FILE NAME =	USER NAME = footemj	DESIGNED -	REVISED - J.A.F. 02-06
ct:\pw\work\pwidot\footemj\d0108315\tc18.dgn		DRAWN -	REVISED - S.P.B. 01-07
	PLOT SCALE = 50.000' / in.	CHECKED -	REVISED - S.P.B. 12-09
	PLOT DATE = 7/8/2013	DATE -	REVISED - M.D. 06-13

STATE OF ILLINOIS
DEPARTMENT OF TRANSPORTATION

FREEWAY/EXPRESSWAY SIGNING FOR FLAGGING OPERATIONS
AT WORK ZONE OPENINGS ON FREEWAYS/EXPRESSWAYS

SCALE: NONE SHEET NO. 1 OF 1 SHEETS STA. TO STA.

F.A. RTE.	SECTION	COUNTY	TOTAL SHEETS	SHEET NO.
2688	2020-250-BY	COOK & WILL	133	108
TC-18		CONTRACT NO.		
FED. ROAD DIST. NO. 1 ILLINOIS FED. AID PROJECT				

ROUTE MARKERS

FOR U.S. ROUTES
M1-40-2424

FOR ILLINOIS ROUTES
M1-50-2424

R.R., UNMARKED ROUTES
SPECIAL 24" x 18" VARIABLE
4" BLACK LETTERS ON WHITE
REFLECTIVE BACKGROUND

ARROWS SIGNS

M5-1L-2115

M5-1R-2115

M6-1-2115

M6-1-2115

M6-3-2115

CARDINAL DIRECTION & DETOUR SIGNS

NORTH M3-1-2412

EAST M3-2-2412

SOUTH M3-3-2412

WEST M3-4-2412

DETOUR M4-8-2412

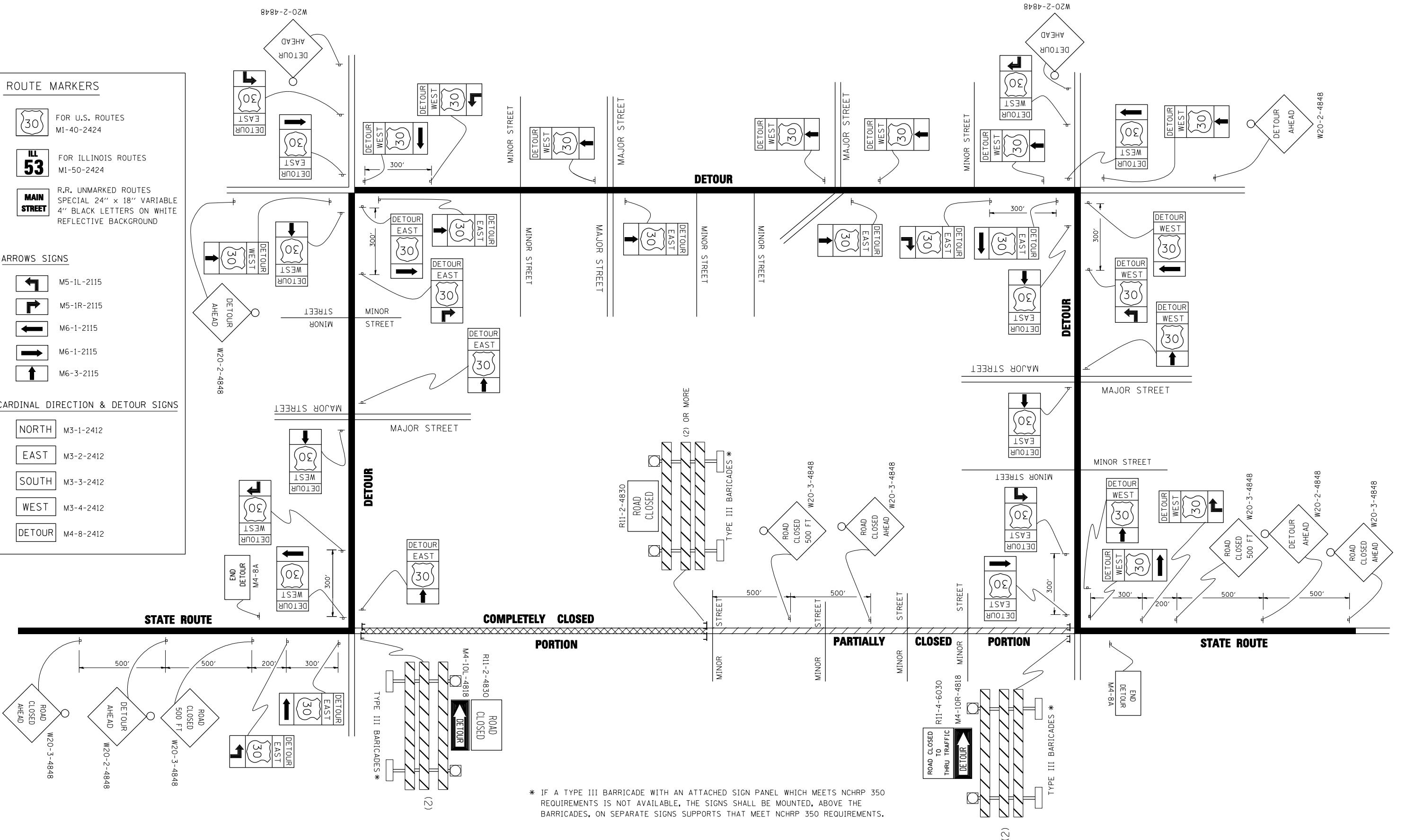

* IF A TYPE III BARRICADE WITH AN ATTACHED SIGN PANEL WHICH MEETS NCHRP 350 REQUIREMENTS IS NOT AVAILABLE, THE SIGNS SHALL BE MOUNTED, ABOVE THE BARRICADES, ON SEPARATE SIGNS SUPPORTS THAT MEET NCHRP 350 REQUIREMENTS.

FILE NAME =	USER NAME = drivakosgn	DESIGNED -	REVISED - 10-18-02
et:\pw\work\PWIDOT\DRIVAKOSGN\d108315\st21.dgn		DRAWN -	REVISED - R. BORO 09-14-09
		PLOT SCALE = 49.9999' / IN.	REVISED -
		CHECKED -	REVISED -
		DATE -	REVISED -

**STATE OF ILLINOIS
DEPARTMENT OF TRANSPORTATION**

DETOUR SIGNING FOR CLOSING STATE HIGHWAYS			
SCALE: NONE	SHEET NO. 1 OF 1 SHEETS	STA.	TO STA.

F.A. RTE.	SECTION	COUNTY	TOTAL SHEETS	SHEET NO.
2688	2020-250-BY	COOK & WILL	133	109
TC-21		CONTRACT NO.		
FED. ROAD DIST. NO. 1 ILLINOIS FED. AID PROJECT				

DATE	
BY	
FINAL SURVEY	SURVEYED
NOTE BOOK	PLOTTED
NO.	TEMPLATE
	AREAS CHECKED

DATE	
BY	
ORIGINAL SURVEY	SURVEYED
NOTE BOOK	PLOTTED
NO.	TEMPLATE
	AREAS CHECKED

MODEL: PRWOLFROAD
FILE NAME: pzjprwrfmra-pw-bentley.com:afmr-a-paw-01 Documents\01 Projects\2017\20200825-00 - DOT Phase II Various Design\20200825-01_WO 1-5 - Wolf Road over I-80\Drawings\Current Drawing Files\CADD_Drawing\roadway\3D Workspace\112323AS Wolf Rd_Shaner.dgn

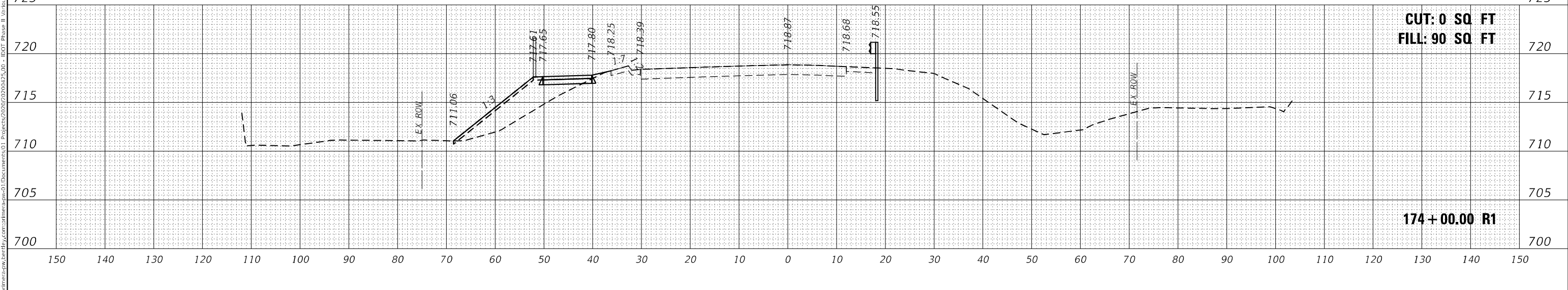
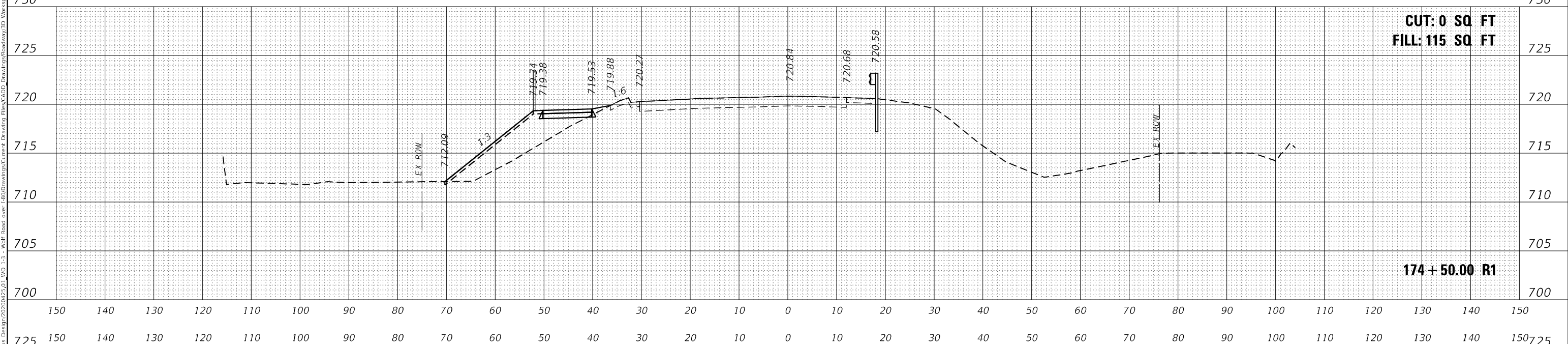
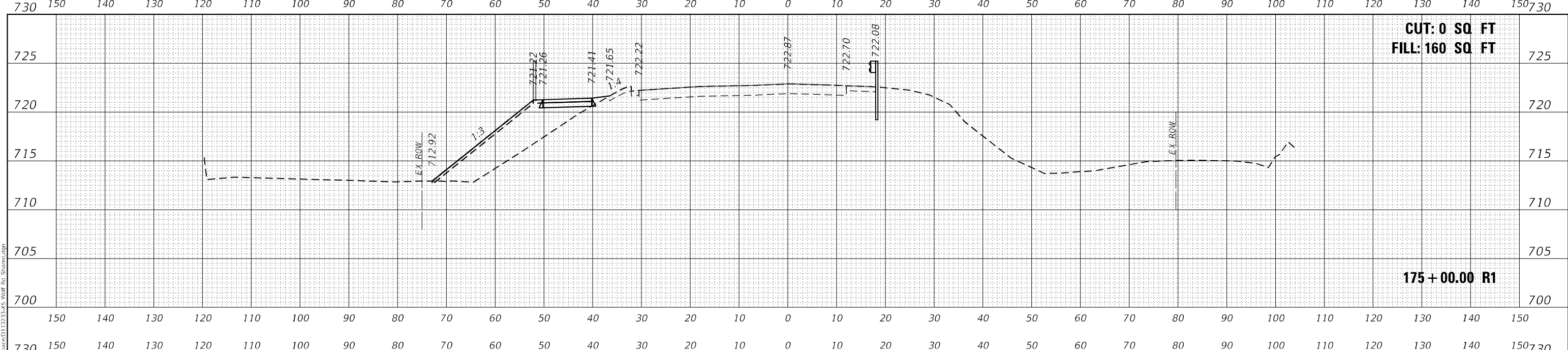

USER NAME	= rvandermus	DESIGNED -	REvised -
		DRAWN -	REvised -
PLOT SCALE	= 20,0012' / in.	CHECKED -	REvised -
PLOT DATE	= 3/10/2022	DATE -	REvised -

**STATE OF ILLINOIS
DEPARTMENT OF TRANSPORTATION**

CROSS SECTIONS			
WOLF ROAD BRIDGE OVER I-80			
SCALE:	SHEET	OF	SHEETS
			STA. 174+00.00 R1 TO STA. 175+00.00 R1

F.A.P. RTE.	SECTION	COUNTY	TOTAL SHEETS	SHEET NO.
2688	2020-250-BY	WILL	133	110
				CONTRACT NO. 62N20
		ILLINOIS	FED. AID PROJECT	

DATE	
BY	
FINAL SURVEY	SURVEYED
NOTE BOOK	PLOTTED
NO.	TEMPLATE
	AREAS CHECKED

DATE	
BY	
ORIGINAL SURVEY	SURVEYED
NOTE BOOK	PLOTTED
NO.	TEMPLATE
	AREAS CHECKED

MODEL: P:\WolfRoad
 FILE NAME: p:\projects\2020\20200825\00 - PLOT Phase II\Visious Design\20200825\01.W01.s - Wolf Road over I-80\Drawings\Current Drawing Files\CADD_Drawing\roadway\3D Workspace\112323.svs Wolf Rd_Shaired.dgn

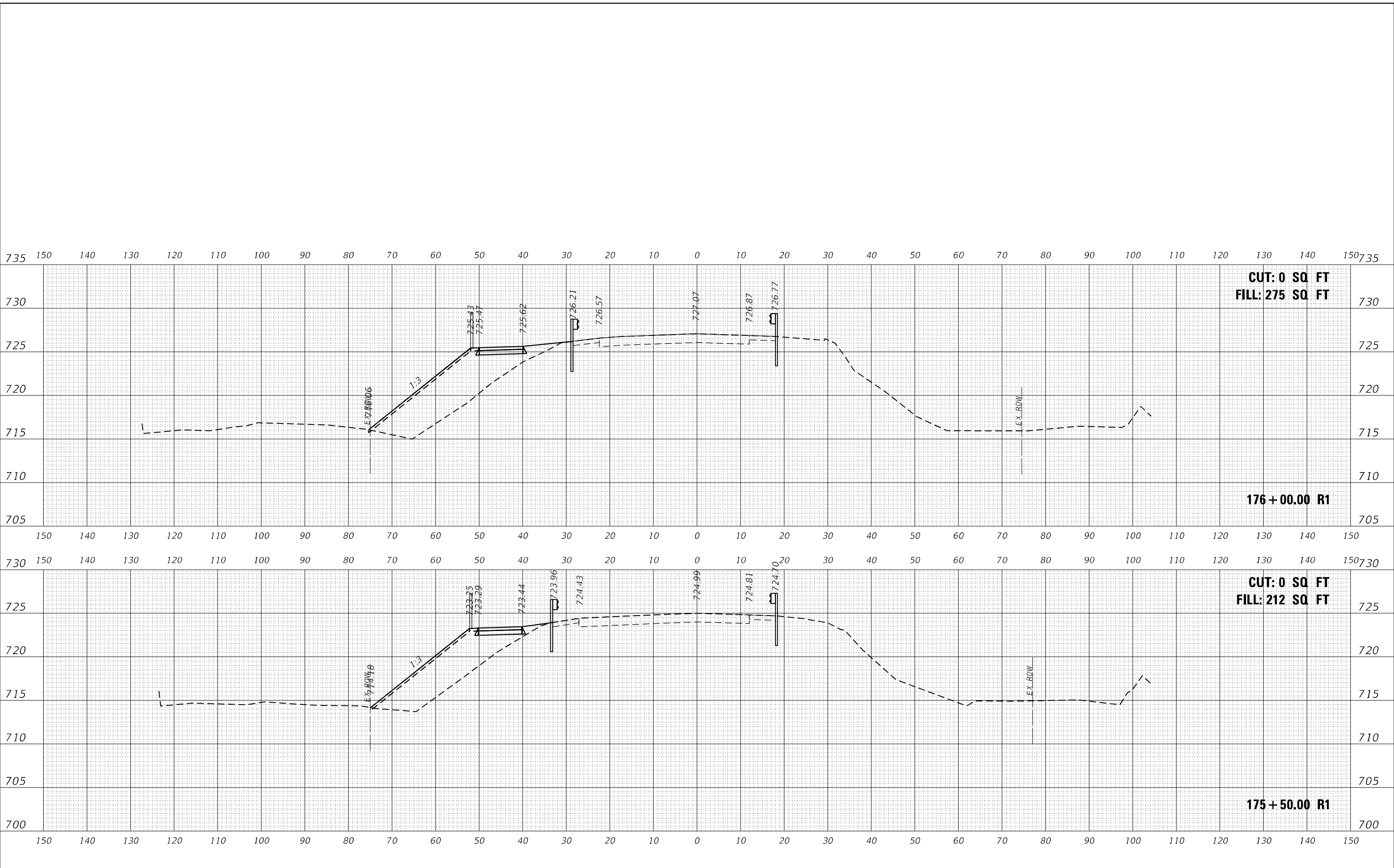

USER NAME	= rvandermus	DESIGNED	-	REVISED	-
		DRAWN	-	REVISED	-
PLOT SCALE	= 20,0012 * / in.	CHECKED	-	REVISED	-
PLOT DATE	= 3/10/2022	DATE	-	REVISED	-

**STATE OF ILLINOIS
 DEPARTMENT OF TRANSPORTATION**

CROSS SECTIONS			
WOLF ROAD BRIDGE OVER I-80			
SCALE:	SHEET	OF	SHEETS
			STA. 175+50.00 R1 TO STA. 176+00.00 R1

F.A.P. RTE.	SECTION	COUNTY	TOTAL SHEETS	SHEET NO.
2688	2020-250-BY	WILL	133	111
				CONTRACT NO. 62N20
ILLINOIS		FED. AID PROJECT		

DATE	
BY	
FINAL SURVEY	SURVEYED
NOTE BOOK	PLOTTED
NO.	TEMPLATE
	AREAS CHECKED

DATE	
BY	
ORIGINAL SURVEY	SURVEYED
NOTE BOOK	PLOTTED
NO.	TEMPLATE
	AREAS CHECKED

MODEL: P:\WolfRoad
 FILE NAME: p:\projects\2020\20200825\00 - DOT Phase II Wolf Road over I-80\Drawings\Current\Drawings\CADD\Drawings\roadway\3D\WorkSpaceD1123\3S Wolf Rd_Shafer.dgn

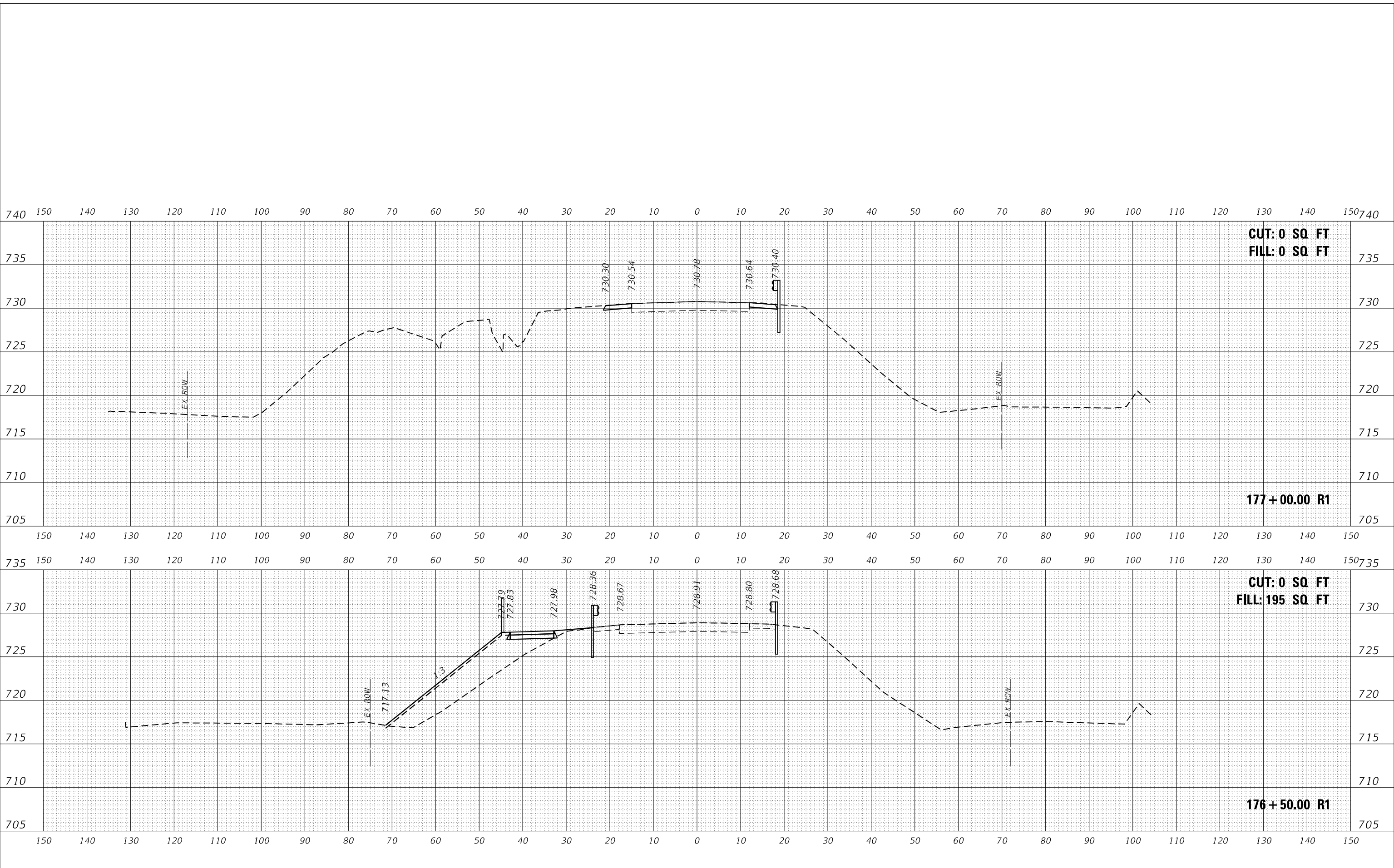

USER NAME	= rvandermus	DESIGNED	-	REVISED	-
		DRAWN	-	REVISED	-
PLOT SCALE	= 20,0012 * / in.	CHECKED	-	REVISED	-
PLOT DATE	= 3/10/2022	DATE	-	REVISED	-

**STATE OF ILLINOIS
 DEPARTMENT OF TRANSPORTATION**

CROSS SECTIONS			
WOLF ROAD BRIDGE OVER I-80			
SCALE:	SHEET	OF	SHEETS
			STA. 176+50.00 R1 TO STA. 177+00.00 R1

F.A.P. RTE.	SECTION	COUNTY	TOTAL SHEETS	SHEET NO.
2688	2020-250-BY	WILL	133	112
				CONTRACT NO. 62N20
		ILLINOIS	FED. AID PROJECT	

DATE	
BY	
FINAL SURVEY	SURVEYED
NOTE BOOK	PLOTTED
NO.	TEMPLATE
	AREAS CHECKED

DATE	
BY	
ORIGINAL SURVEY	SURVEYED
NOTE BOOK	PLOTTED
NO.	TEMPLATE
	AREAS CHECKED

MODEL: P:\WolfRoad
 FILE NAME: p:\proj\p177\250\20200825\00 - PLOT Phase II Wolf Road over I-80\Drawings\Current\Drawing Files\CADD_Drawing\roadway\3D WorkSpace\1123\3AS Wolf Rd_Shafer.dgn

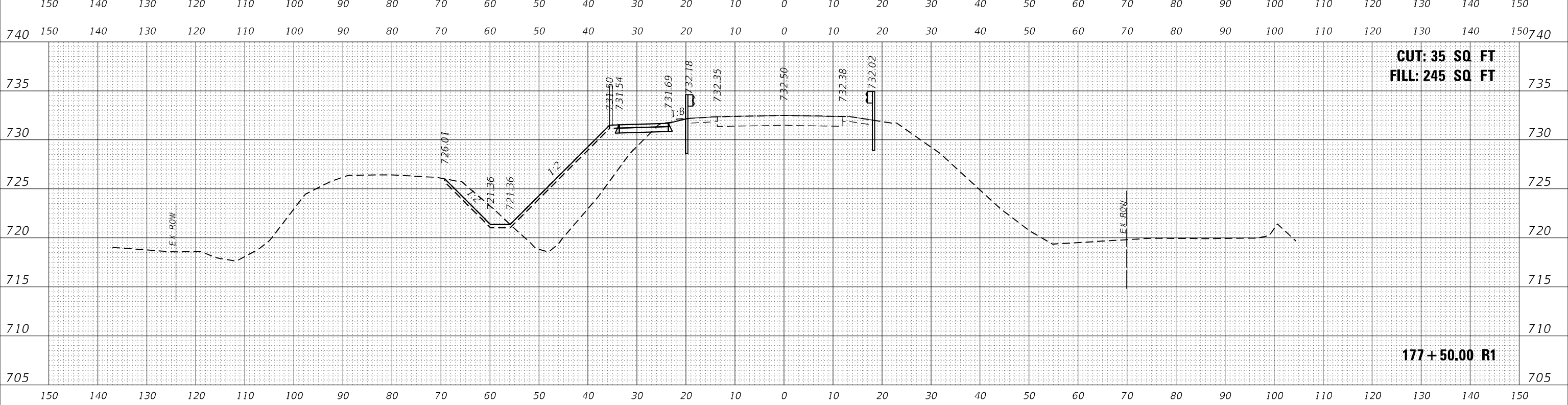
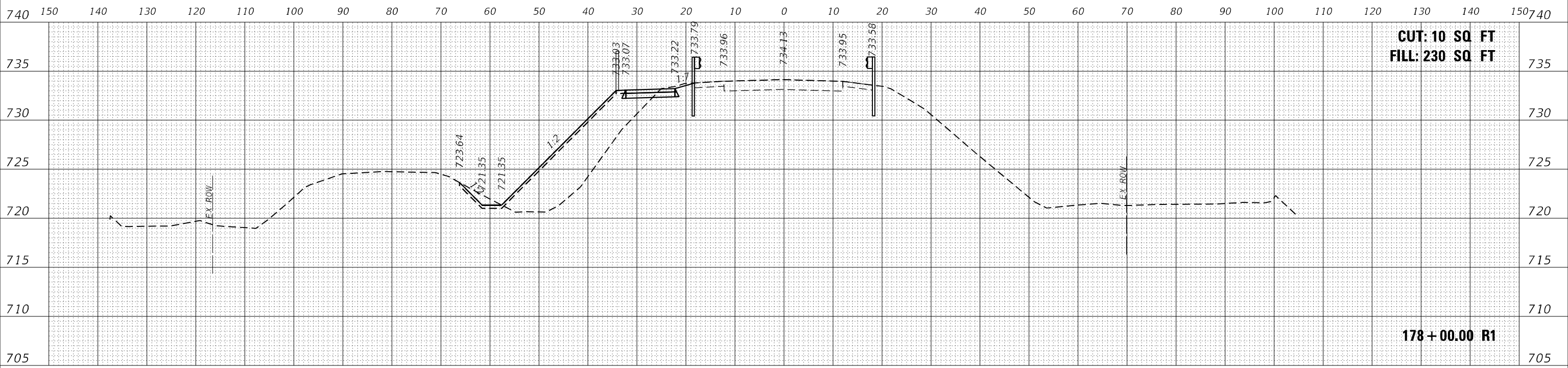

USER NAME	= rvanderdus	DESIGNED	-	REVISED	-
		DRAWN	-	REVISED	-
PLOT SCALE	= 20,0012 * / in.	CHECKED	-	REVISED	-
PLOT DATE	= 3/10/2022	DATE	-	REVISED	-

**STATE OF ILLINOIS
DEPARTMENT OF TRANSPORTATION**

**CROSS SECTIONS
WOLF ROAD BRIDGE OVER I-80**

SCALE: SHEET OF SHEETS STA. 177+50.00 R1 TO STA. 178+00.00 R1

F.A.P. RTE.	SECTION	COUNTY	TOTAL SHEETS	SHEET NO.
2688	2020-250-BY	WILL	133	113
CONTRACT NO. 62N20				
ILLINOIS FED. AID PROJECT				

DATE	
BY	
FINAL SURVEY	SURVEYED
NOTE BOOK	PLOTTED
NO.	TEMPLATE
	AREAS CHECKED

DATE	
BY	
ORIGINAL SURVEY	SURVEYED
NOTE BOOK	PLOTTED
NO.	TEMPLATE
	AREAS CHECKED

MODEL: PRWofRoad
 FILE NAME: pzjprwofroad.pw.bentley.com:prwofroad.dwg
 PROJECTS\2017\20200825\00 - DOT Phase II Visible Design\20200825\01 WO 1-3 - Wolf Road over I-80\Drawings\Cross Sections\179+00.00 R1.dwg
 NO. 179+00.00 R1

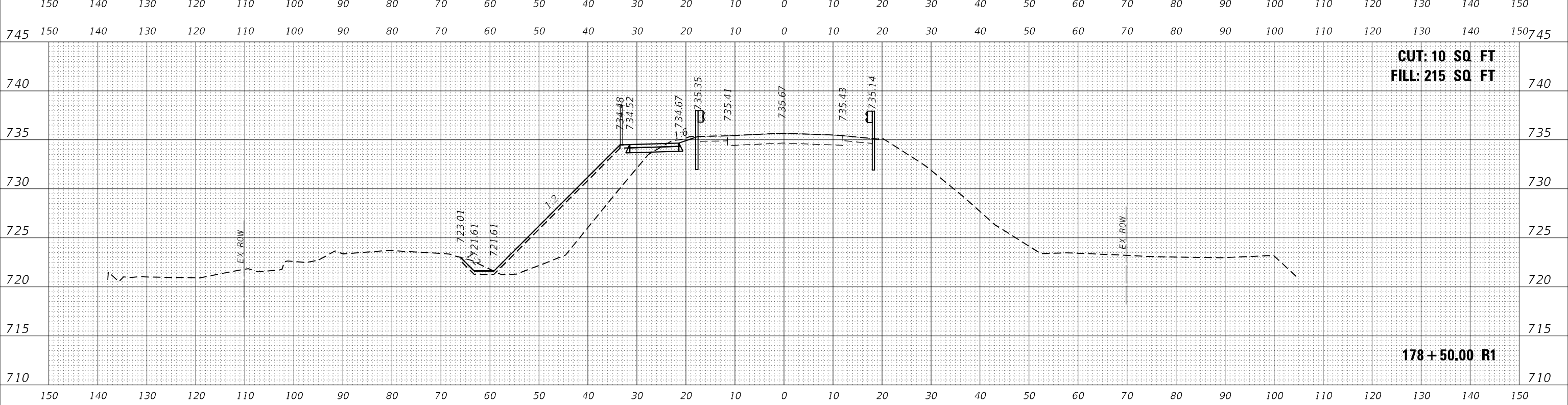
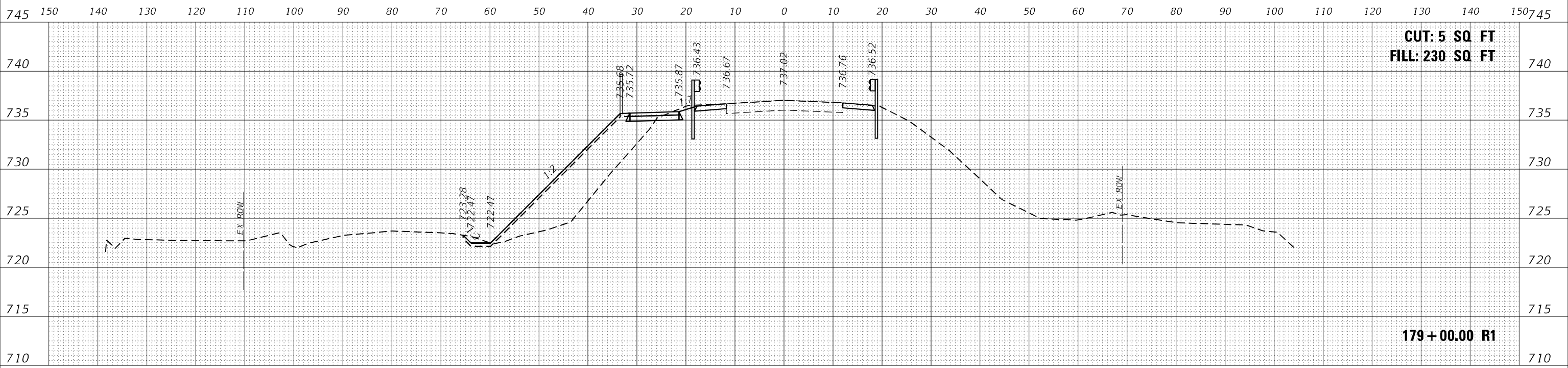

USER NAME	= rvandermus	DESIGNED -	REVISED -
		DRAWN -	REVISED -
PLOT SCALE	= 20,0012 * / in.	CHECKED -	REVISED -
PLOT DATE	= 3/10/2022	DATE -	REVISED -

**STATE OF ILLINOIS
DEPARTMENT OF TRANSPORTATION**

**CROSS SECTIONS
WOLF ROAD BRIDGE OVER I-80**

SCALE: SHEET OF SHEETS STA. 178+50.00 R1 TO STA. 179+00.00 R1

F.A.P. RTE.	SECTION	COUNTY	TOTAL SHEETS	SHEET NO.
2688	2020-250-BY	WILL	133	114
CONTRACT NO. 62N20				
ILLINOIS FED. AID PROJECT				

FINAL SURVEY	SURVEYED	BY	DATE
NOTE BOOK	PLOTTED		
NO.	TEMPLATE		
	AREAS CHECKED		

ORIGINAL SURVEY	SURVEYED	BY	DATE
NOTE BOOK	PLOTTED		
NO.	TEMPLATE		
	AREAS CHECKED		

MODEL: P:\WolfRoad
 FILE NAME: p:\proj\p179+50.00\20200825\DOT Phase II\Visious Design\20200825\01_WO 1-3 - Wolf Road over I-80\Drawings\Current Drawing Files\CADD_Drawing\roadway\3D Workspace\112333\AS Wolf Rd_Shafer.dgn

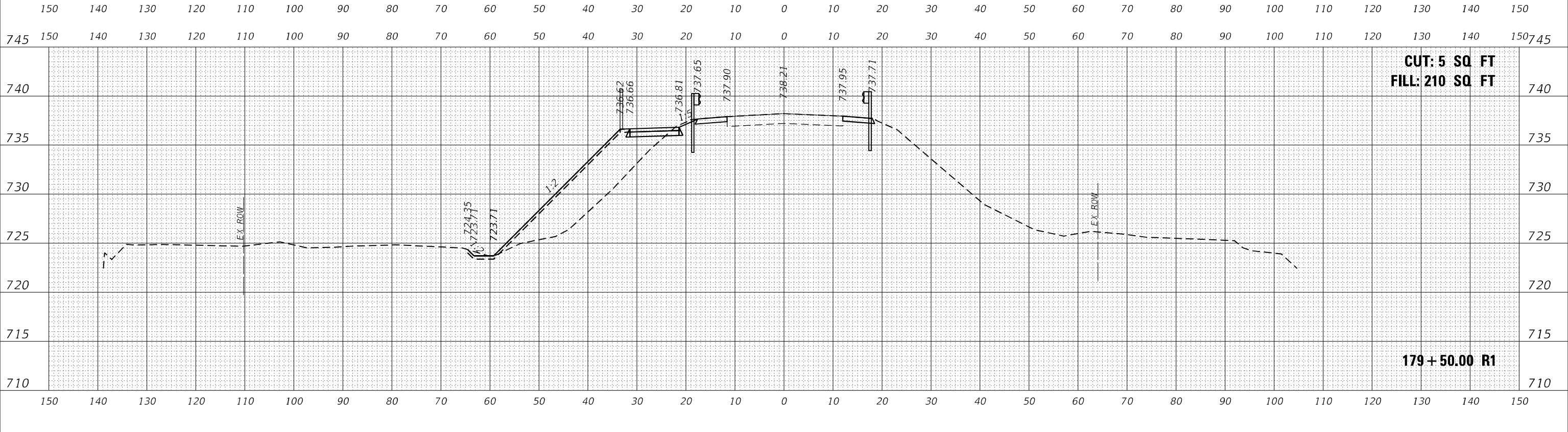
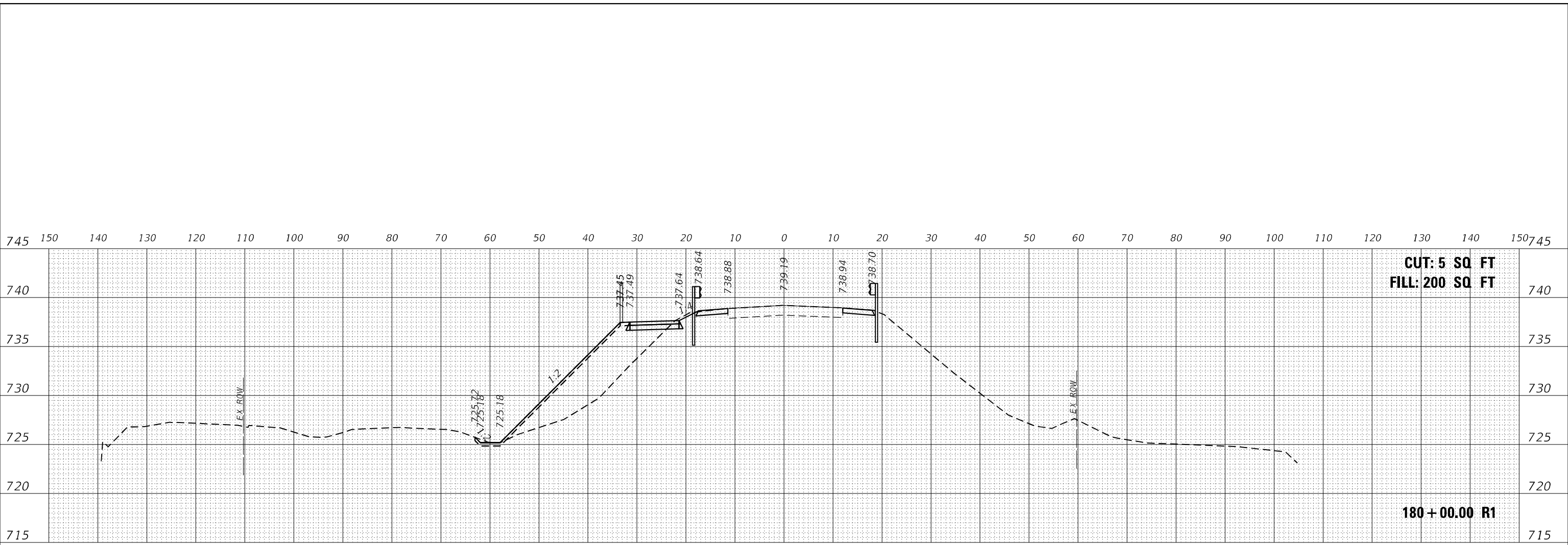

USER NAME	= rvandermus	DESIGNED	-	REVISED	-
		DRAWN	-	REVISED	-
PLOT SCALE	= 20,0012 * / in.	CHECKED	-	REVISED	-
PLOT DATE	= 3/10/2022	DATE	-	REVISED	-

**STATE OF ILLINOIS
DEPARTMENT OF TRANSPORTATION**

CROSS SECTIONS			
WOLF ROAD BRIDGE OVER I-80			
SCALE:	SHEET	OF	SHEETS
			STA. 179+50.00 R1 TO STA. 180+00.00 R1

F.A.P. RTE.	SECTION	COUNTY	TOTAL SHEETS	SHEET NO.
2688	2020-250-BY	WILL	133	115
CONTRACT NO. 62N20				
ILLINOIS FED. AID PROJECT				

DATE	
BY	
FINAL SURVEY	SURVEYED
NOTE BOOK	PLOTTED
NO.	TEMPLATE
	AREAS CHECKED

DATE	
BY	
ORIGINAL SURVEY	SURVEYED
NOTE BOOK	PLOTTED
NO.	TEMPLATE
	AREAS CHECKED

MODEL: P:\WolfRoad
 FILE NAME: p:\proj\p180250\p180250.dwg - PLOT Phase II Wolf Road over I-80
 PROJECTS\01\Projects\2020\00250.dwg - PLOT Phase II Wolf Road over I-80
 DRAWING\roadway\3D\WorkSpaceD1123\3S Wolf Rd_Shafer.dgn

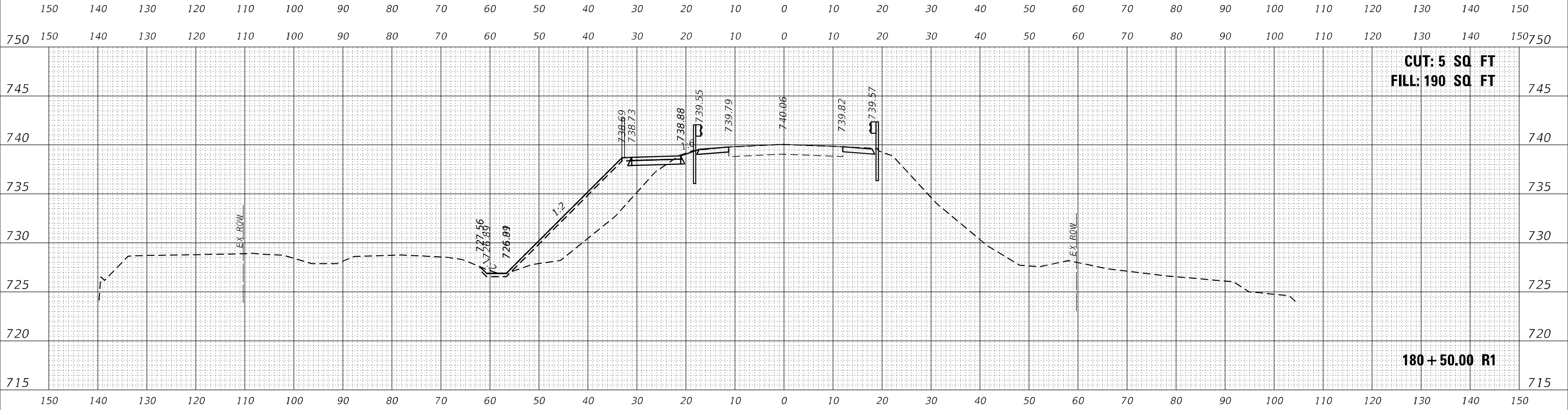
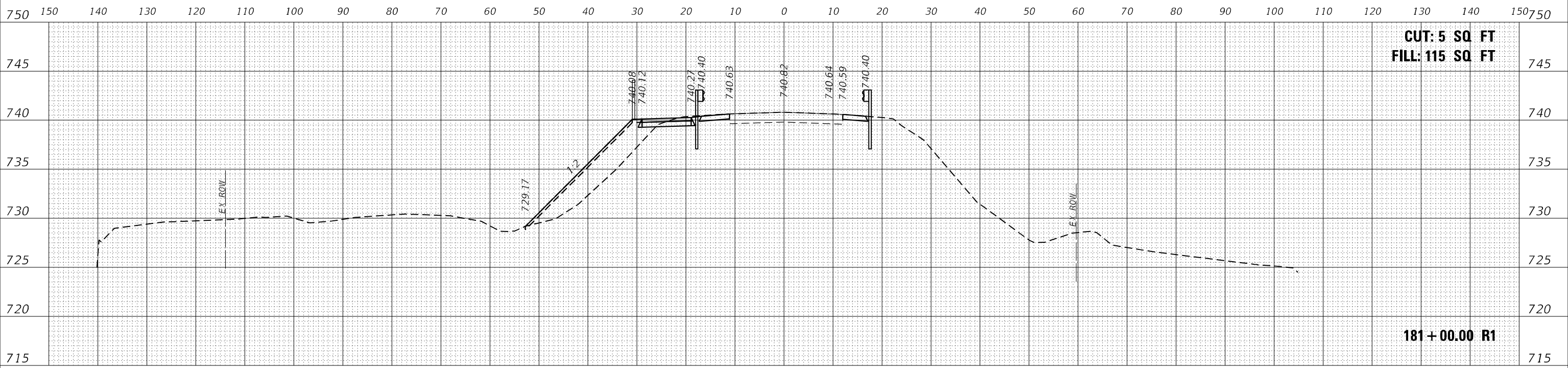

USER NAME	= rvandermus	DESIGNED -	REVISED -
		DRAWN -	REVISED -
PLOT SCALE	= 20,0012 * / in.	CHECKED -	REVISED -
PLOT DATE	= 3/10/2022	DATE -	REVISED -

**STATE OF ILLINOIS
DEPARTMENT OF TRANSPORTATION**

**CROSS SECTIONS
WOLF ROAD BRIDGE OVER I-80**

SCALE: SHEET OF SHEETS STA. 180+50.00 R1 TO STA. 181+00.00 R1

F.A.P. RTE.	SECTION	COUNTY	TOTAL SHEETS	SHEET NO.
2688	2020-250-BY	WILL	133	116
				CONTRACT NO. 62N20
		ILLINOIS	FED. AID PROJECT	

FINAL SURVEY	SURVEYED	DATE
NOTE BOOK	PLOTTED	BY
AREAS CHECKED	TEMPLATE	
NO.	AREAS CHECKED	

ORIGINAL SURVEY	SURVEYED	DATE
NOTE BOOK	PLOTTED	BY
AREAS CHECKED	TEMPLATE	
NO.	AREAS CHECKED	

MODEL: PRWOLFROAD
 FILE NAME: pzjprwrfmra-pw-bentley.com:prwrfmra-pw-3D-Drawings\roadway\3D-Drawings\Cross\Current-Drawings\Cross\181+50.00 R1.dwg
 NO. 1-3 - Wolf Road over I-80 Drawings\Current-Drawings\Cross\181+50.00 R1.dwg
 NO. 1-5 - Wolf Road over I-80 Drawings\Current-Drawings\Cross\182+00.00 R1.dwg

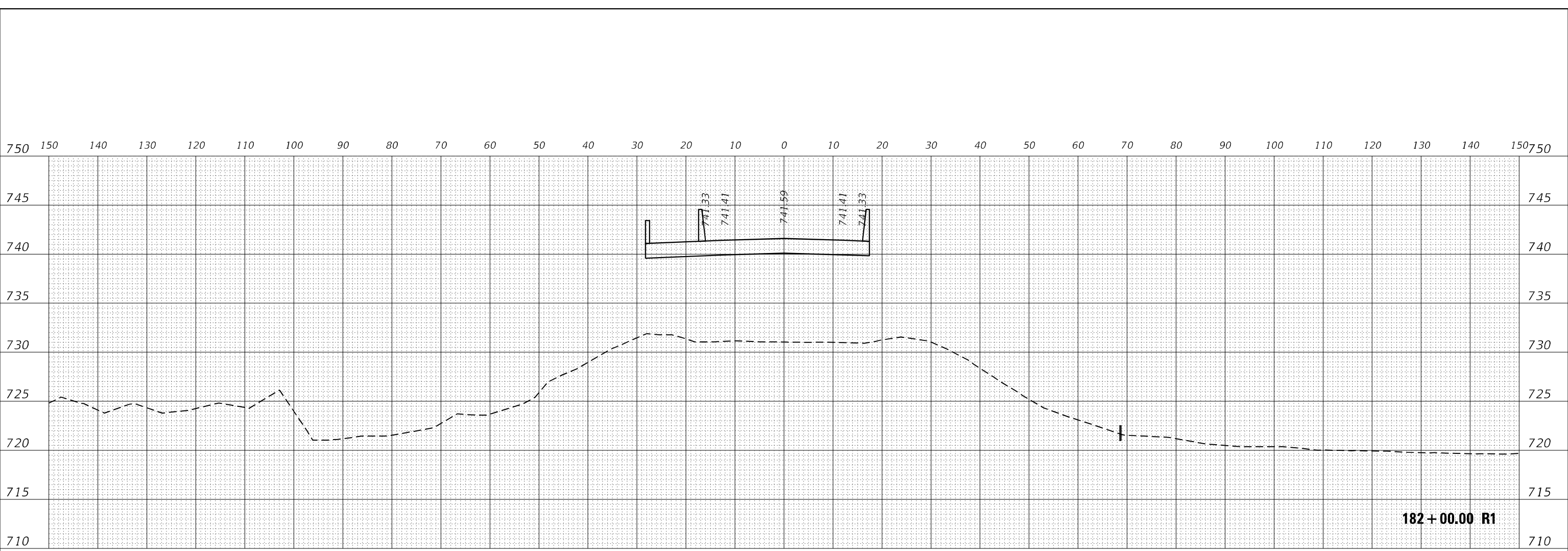

182+00.00 R1

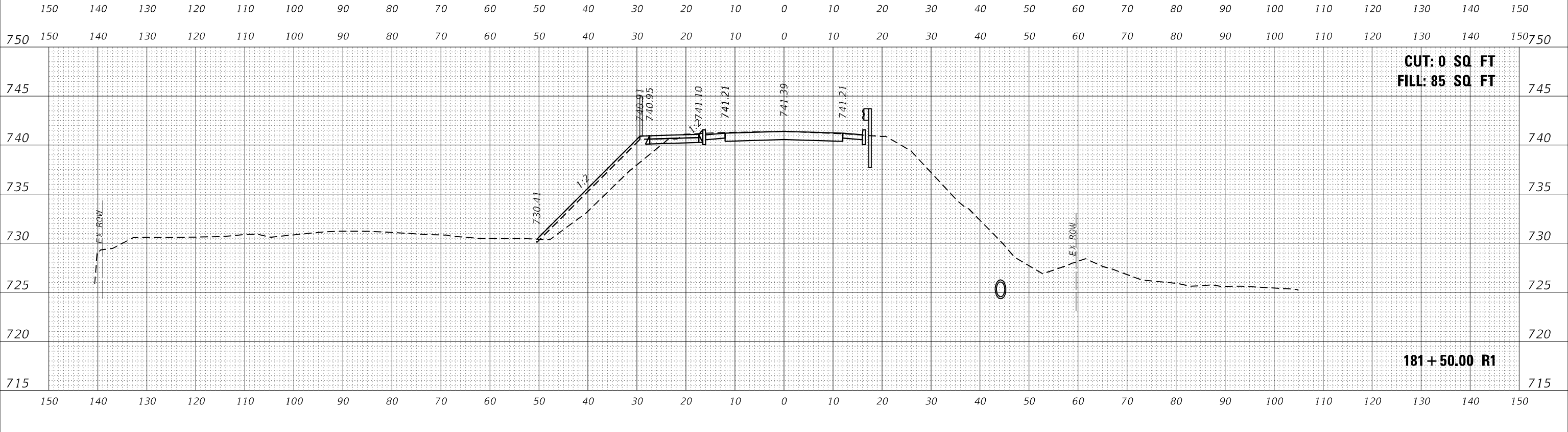

CUT: 0 SQ FT
 FILL: 85 SQ FT

181+50.00 R1

USER NAME	= rvandermus	DESIGNED -	REVISED -
		DRAWN -	REVISED -
PLOT SCALE	= 20,0012 * / in.	CHECKED -	REVISED -
PLOT DATE	= 3/10/2022	DATE -	REVISED -

**STATE OF ILLINOIS
 DEPARTMENT OF TRANSPORTATION**

**CROSS SECTIONS
 WOLF ROAD BRIDGE OVER I-80**

SCALE: SHEET OF SHEETS STA. 181+50.00 R1 TO STA. 182+00.00 R1

F.A.P. RTE.	SECTION	COUNTY	TOTAL SHEETS	SHEET NO.
2688	2020-250-BY	WILL	133	117
				CONTRACT NO. 62N20
				ILLINOIS FED. AID PROJECT

DATE	
BY	
FINAL SURVEY	
NOTE BOOK	
NO.	
SURVEYED	
PLOTTED	
TEMPLATE	
AREAS CHECKED	

DATE	
BY	
ORIGINAL SURVEY	
NOTE BOOK	
NO.	
SURVEYED	
PLOTTED	
TEMPLATE	
AREAS CHECKED	

MODEL: P:\WolfRoad
 FILE NAME: p:\proj\prj\mra-pw-bentley.com\at\mra-paw\c\Documents\DOT Phase II\Various Design\2020\25\01\VO 1-3 - Wolf Road over I-80\Drawings\Current Drawings Files\CADD\Drawings\toairway3D\Workspace\013233\YS Wolf Rd Shore.dgn

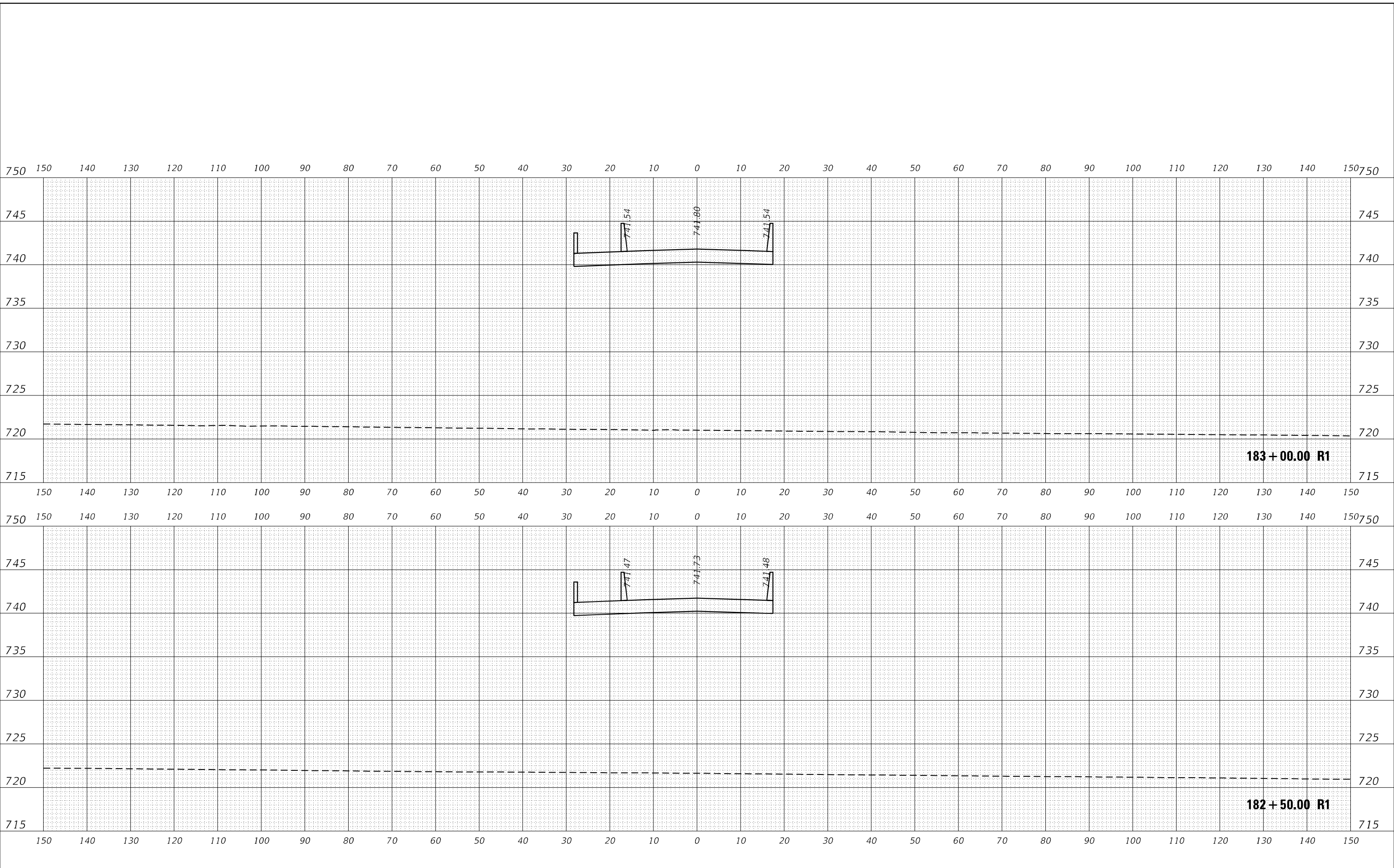

USER NAME = rmarlin	DESIGNED -	REVISED -
	DRAWN -	REVISED -
PLOT SCALE = 20,0012' / in.	CHECKED -	REVISED -
PLOT DATE = 7/2/2022	DATE -	REVISED -

**STATE OF ILLINOIS
DEPARTMENT OF TRANSPORTATION**

CROSS SECTIONS			
WOLF ROAD BRIDGE OVER I-80			
SCALE:	SHEET	OF	SHEETS
			STA. 182+50.00 R1 TO STA. 183+00.00 R1

F.A.P. RTE.	SECTION	COUNTY	TOTAL SHEETS	SHEET NO.
2688	2020-250-BY	WILL	133	118
CONTRACT NO. 62N20				
ILLINOIS		FED. AID PROJECT		

FINAL SURVEY	SURVEYED	BY	DATE
NOTE BOOK	PLOTTED		
NO.	TEMPLATE		
	AREAS CHECKED		

ORIGINAL SURVEY	SURVEYED	BY	DATE
NOTE BOOK	PLOTTED		
NO.	TEMPLATE		
	AREAS CHECKED		

MODEL: P:\WolfRoad
 FILE NAME: p:\proj\prj\paw_bentley.com\at\mra\paw\DOT Phase II Various Design\2020\25\01\VO 1-3 - Wolf Road over I-80\Drawings\Curent Drawing Files\CADD\Drawings\toairway3D\Workspace\013233\YS Wolf Rd Shore.dgn

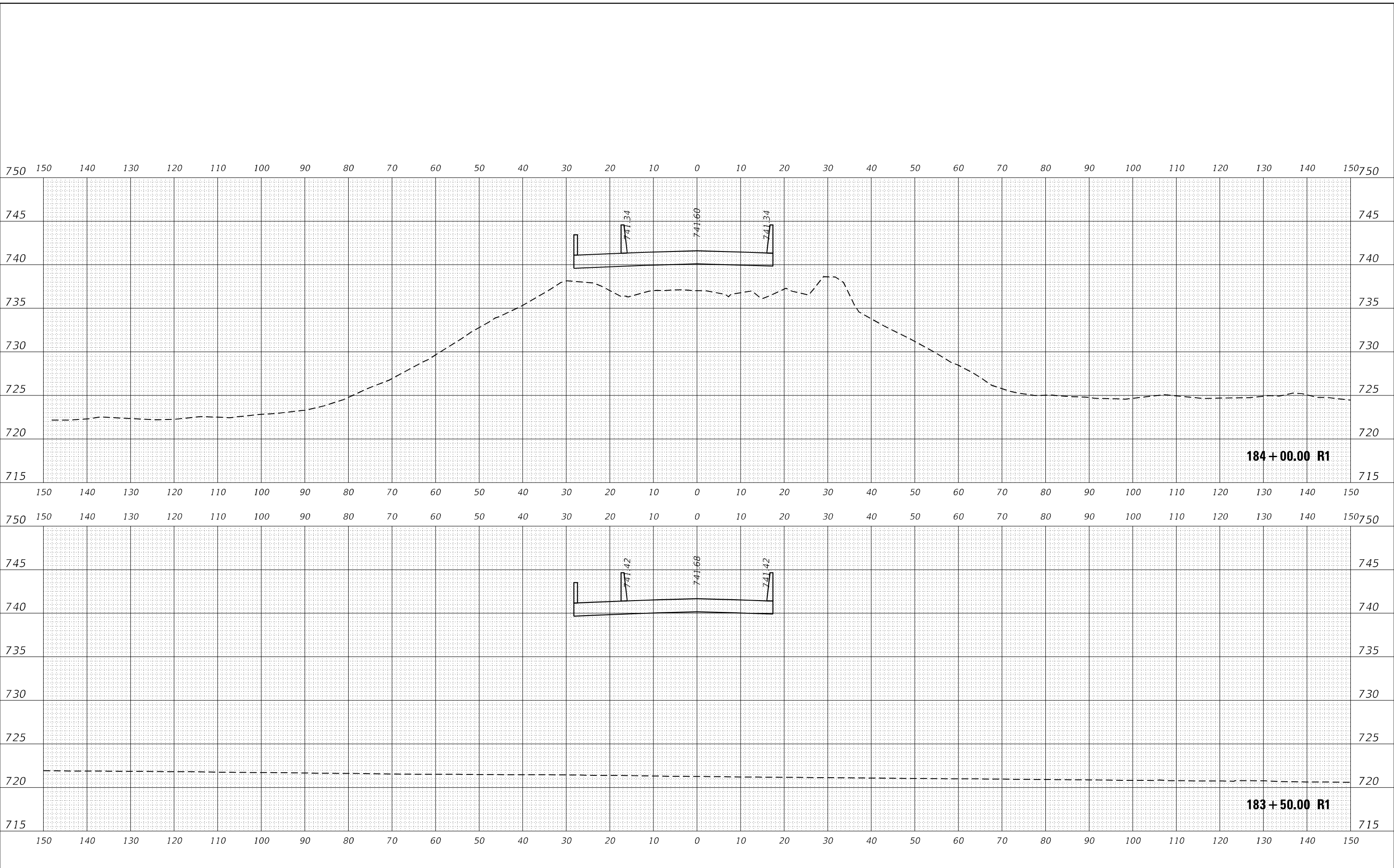

USER NAME = rmarlin	DESIGNED -	REVISED -
	DRAWN -	REVISED -
PLOT SCALE = 20,0012' / in.	CHECKED -	REVISED -
PLOT DATE = 7/2/2022	DATE -	REVISED -

**STATE OF ILLINOIS
DEPARTMENT OF TRANSPORTATION**

CROSS SECTIONS			
WOLF ROAD BRIDGE OVER I-80			
SCALE:	SHEET	OF	SHEETS
			STA. 183+50.00 R1 TO STA. 184+00.00 R1

F.A.P. RTE.	SECTION	COUNTY	TOTAL SHEETS	SHEET NO.
2688	2020-250-BY	WILL	133	119
				CONTRACT NO. 62N20
ILLINOIS		FED. AID PROJECT		

DATE	
BY	
FINAL SURVEY	SURVEYED
NOTE BOOK	PLOTTED
NO.	TEMPLATE
	AREAS CHECKED

DATE	
BY	
ORIGINAL SURVEY	SURVEYED
NOTE BOOK	PLOTTED
NO.	TEMPLATE
	AREAS CHECKED

MODEL: P:\WolfRoad
 FILE NAME: p:\projects\2020\20200825\00 - DOT Phase II Wolf Road over I-80\Drawings\Current Drawings\CADD_Drawing\roadway\3D WorkSpace\11233\AS Wolf Rd_Shafer.dgn

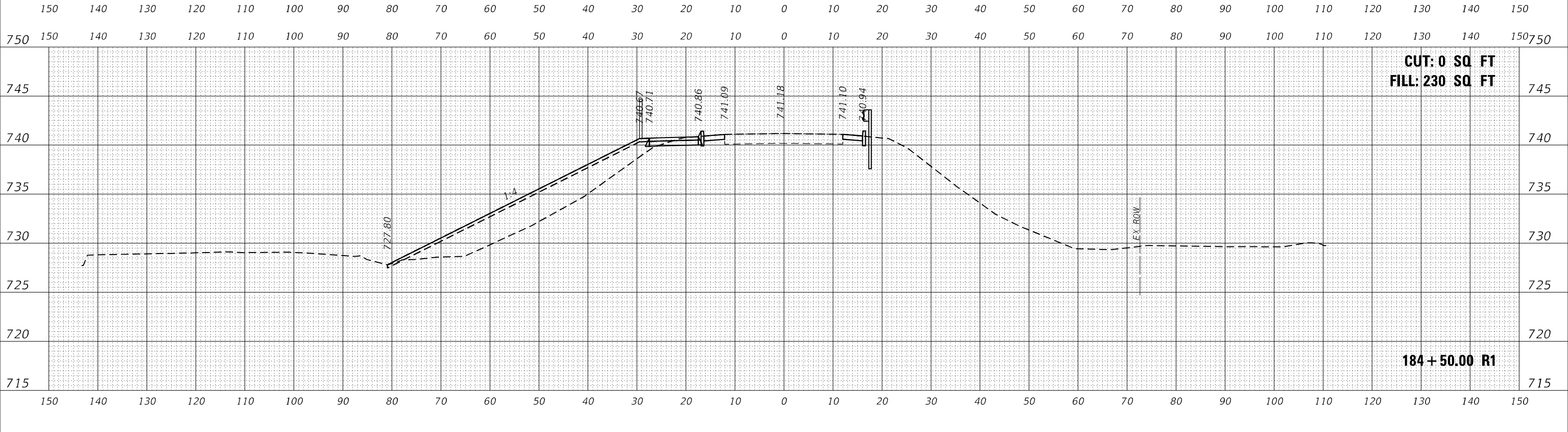
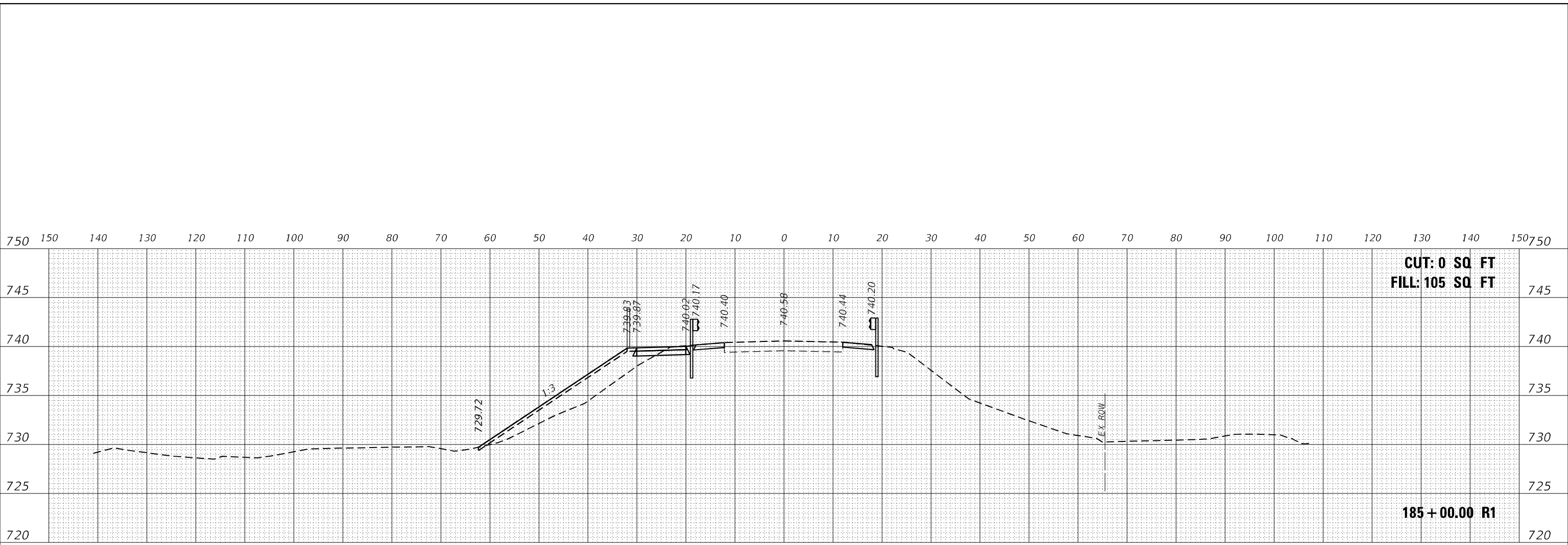

USER NAME	= rvandermus	DESIGNED	-	REVISED	-
		DRAWN	-	REVISED	-
PLOT SCALE	= 20,0012 * / in.	CHECKED	-	REVISED	-
PLOT DATE	= 3/10/2022	DATE	-	REVISED	-

**STATE OF ILLINOIS
DEPARTMENT OF TRANSPORTATION**

CROSS SECTIONS			
WOLF ROAD BRIDGE OVER I-80			
SCALE:	SHEET	OF	SHEETS
			STA. 184+50.00 R1 TO STA. 185+00.00 R1

F.A.P. RTE.	SECTION	COUNTY	TOTAL SHEETS	SHEET NO.
2688	2020-250-BY	WILL	133	120
CONTRACT NO. 62N20				
ILLINOIS FED. AID PROJECT				

FINAL SURVEY	SURVEYED	BY	DATE
NOTE BOOK	PLOTTED		
NO.	TEMPLATE		
	AREAS CHECKED		

ORIGINAL SURVEY	SURVEYED	BY	DATE
NOTE BOOK	PLOTTED		
NO.	TEMPLATE		
	AREAS CHECKED		

MODEL: P:\WolfRoad
 FILE NAME: p:\projects\2020\20200425-00 - DOT Phase II Wolf Road over I-80\Drawings\Current\Drawings\roadway\3D\WorkSpaceD112333\AS Wolf Rd_Shafer.dgn

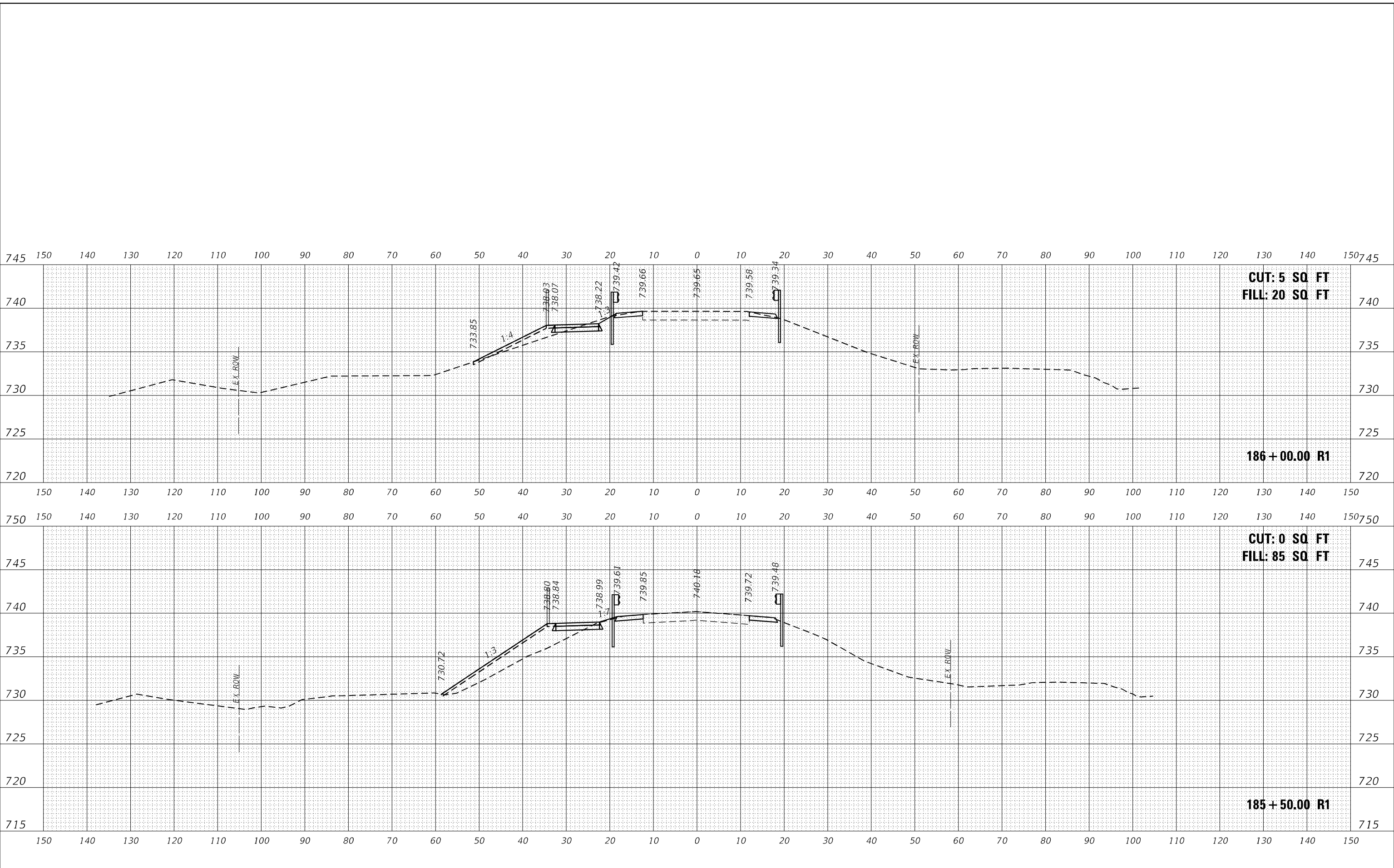

USER NAME = rvandermus	DESIGNED -	REVISED -
PLOT SCALE = 20,0012 * / in.	DRAWN -	REVISED -
PLOT DATE = 3/10/2022	CHECKED -	REVISED -
	DATE -	REVISED -

**STATE OF ILLINOIS
 DEPARTMENT OF TRANSPORTATION**

CROSS SECTIONS			
WOLF ROAD BRIDGE OVER I-80			
SCALE:	SHEET	OF	SHEETS
			STA. 185+50.00 R1 TO STA. 186+00.00 R1

F.A.P. RTE.	SECTION	COUNTY	TOTAL SHEETS	SHEET NO.
2688	2020-250-BY	WILL	133	121
				CONTRACT NO. 62N20
				ILLINOIS FED. AID PROJECT

DATE	
BY	
FINAL SURVEY	SURVEYED
NOTE BOOK	PLOTTED
NO.	TEMPLATE
	AREAS CHECKED
	AREAS CHECKED

DATE	
BY	
ORIGINAL SURVEY	SURVEYED
NOTE BOOK	PLOTTED
NO.	TEMPLATE
	AREAS CHECKED
	AREAS CHECKED

MODEL: P:\R\WolfRoad
 FILE NAME: p:\projects\2020\20200825-00 - DOT Phase II Various Design\20200825-01.W01.s - Wolf Road over I-80\Drawings\Current Drawing Files\CADD_Drawing\roadway\3D Workspaces\112323.svs Wolf Rd Spine.dgn

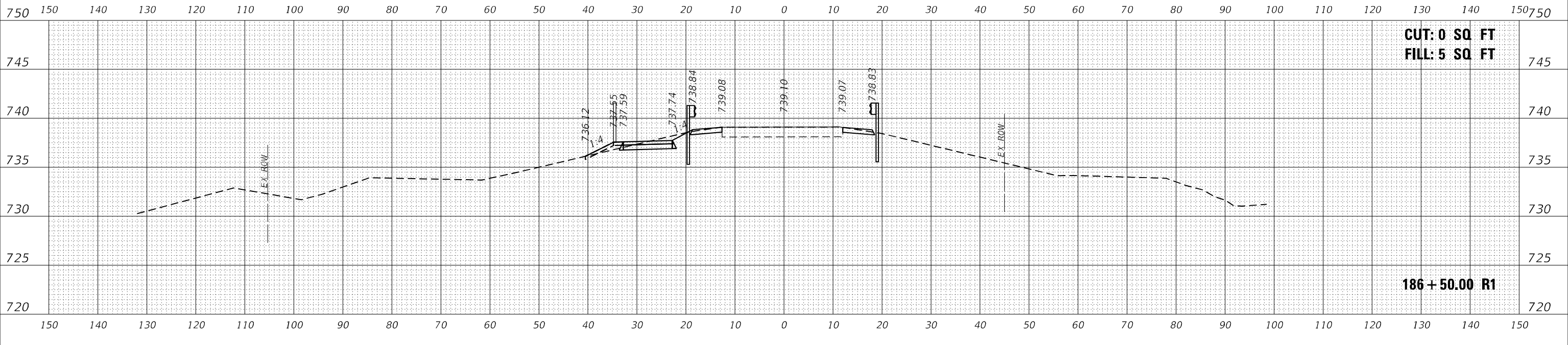
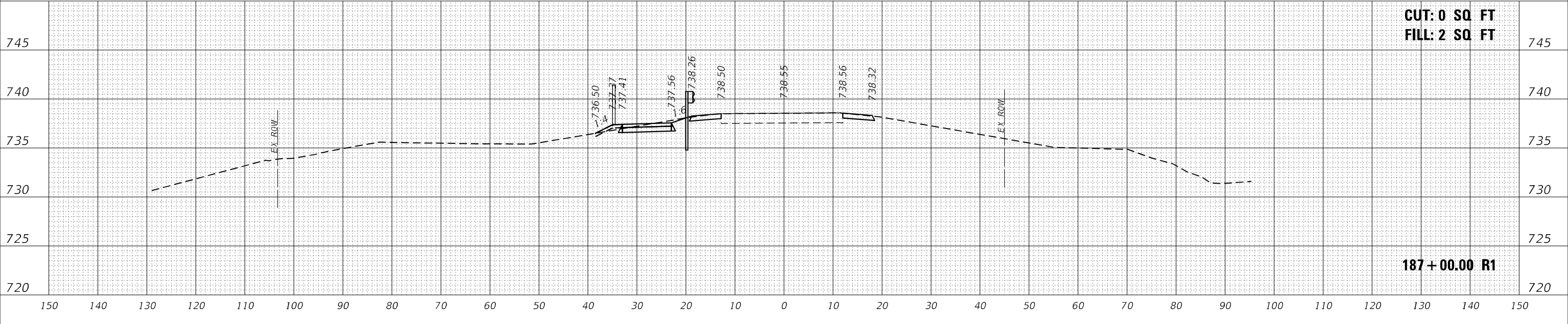
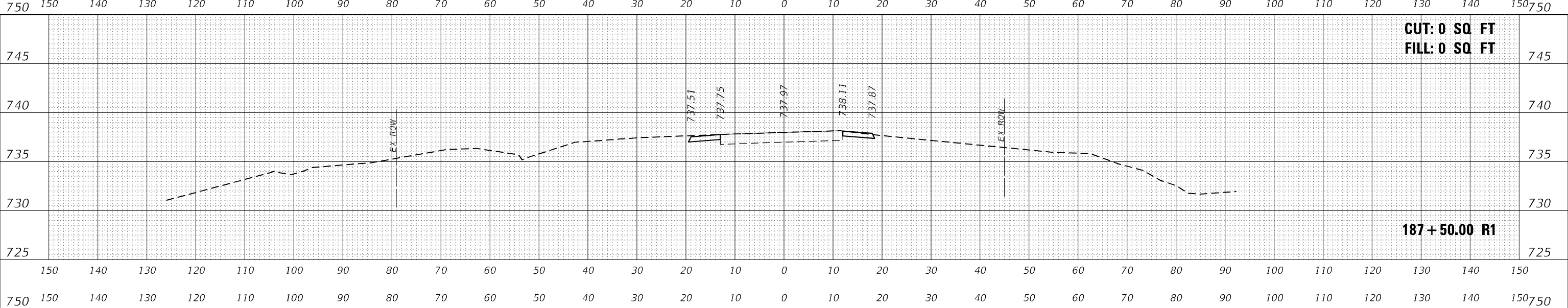

USER NAME	= rvandermus	DESIGNED	-	REVISED	-
		DRAWN	-	REVISED	-
PLOT SCALE	= 20,0012 * / in.	CHECKED	-	REVISED	-
PLOT DATE	= 3/10/2022	DATE	-	REVISED	-

**STATE OF ILLINOIS
DEPARTMENT OF TRANSPORTATION**

CROSS SECTIONS			
WOLF ROAD BRIDGE OVER I-80			
SCALE:	SHEET	OF	SHEETS
			STA. 186+50.00 R1 TO STA. 187+50.00 R1

F.A.P. RTE.	SECTION	COUNTY	TOTAL SHEETS	SHEET NO.
2688	2020-250-BY	WILL	133	122
			CONTRACT NO. 62N20	
		ILLINOIS	FED. AID PROJECT	

DATE	
BY	
FINAL SURVEY	
NOTED BOOK	
PLOTTED	
TEMPLATE	
AREAS CHECKED	
NO.	

DATE	
BY	
ORIGINAL SURVEY	
NOTED BOOK	
PLOTTED	
TEMPLATE	
AREAS CHECKED	
NO.	

MODEL: P:\WolfRoad
 FILE NAME: p:\proj\mra-pw-bentley.com\atkins-paw-01\Documents\01\Projects\2017\20200825-00 - DOT Phase II\Various Design\20200825-01_WO 1-3 - Wolf Road over I-80\Drawings\Current\Drawings\CADD\Drawing\Roadway\3D\WorkSpace\112323AS Wolf Rd Spine.dgn

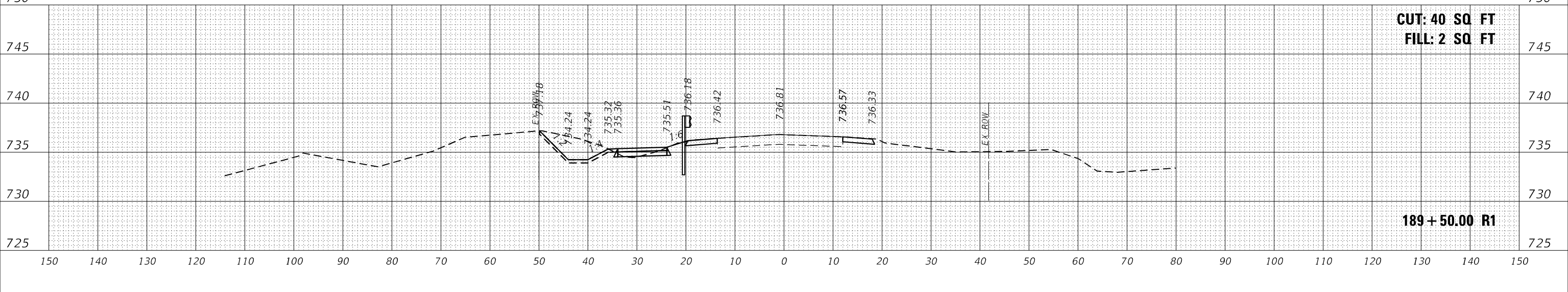
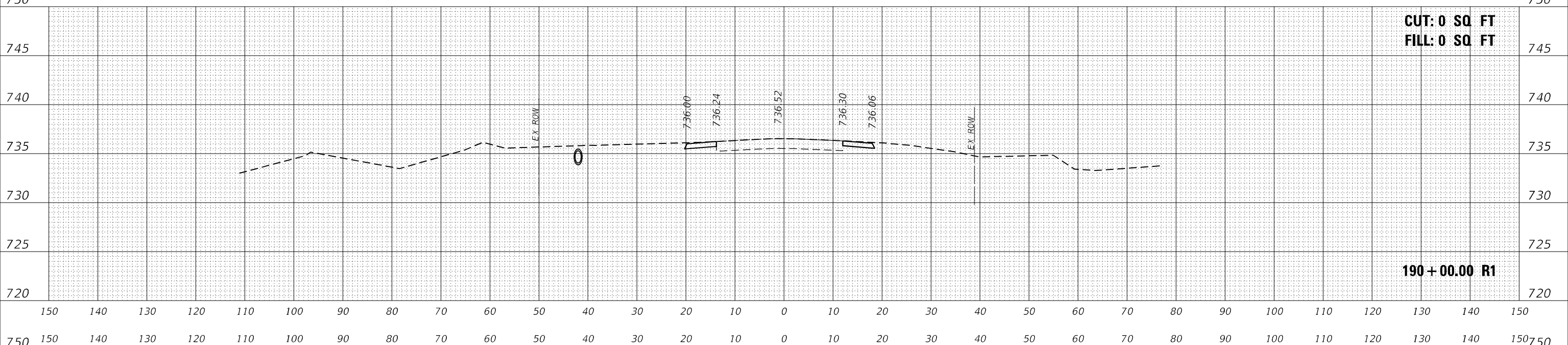
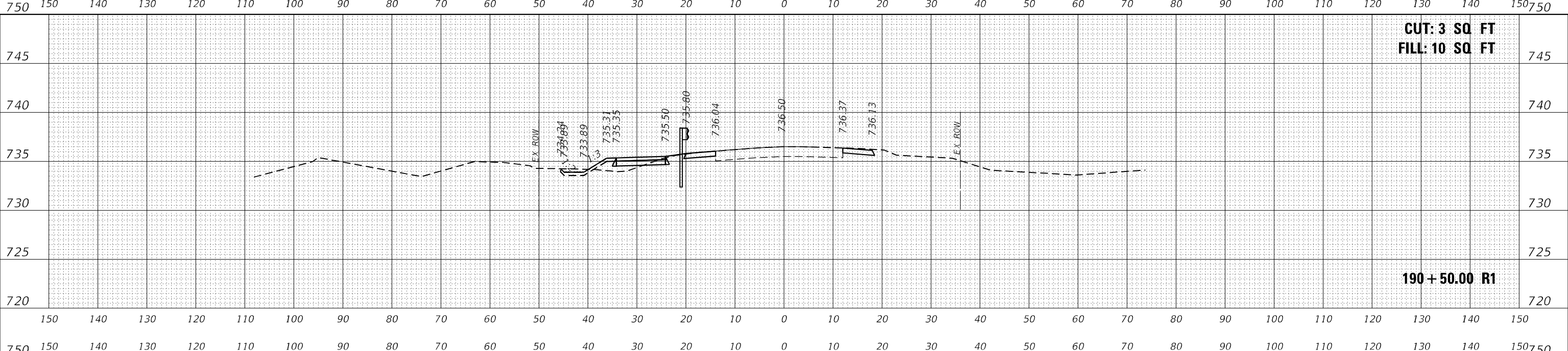

USER NAME = rvandermus	DESIGNED -	REVISED -
	DRAWN -	REVISED -
PLOT SCALE = 20,0012' */ in.	CHECKED -	REVISED -
PLOT DATE = 3/10/2022	DATE -	REVISED -

STATE OF ILLINOIS
DEPARTMENT OF TRANSPORTATION

CROSS SECTIONS
WOLF ROAD BRIDGE OVER I-80

SCALE: SHEET OF SHEETS STA. 189+50.00 R1 TO STA. 190+50.00 R1

F.A.P. RTE.	SECTION	COUNTY	TOTAL SHEETS	SHEET NO.
2688	2020-250-BY	WILL	133	124
CONTRACT NO. 62N20				
ILLINOIS		FED. AID PROJECT		

DATE	
BY	
FINAL SURVEY	
NOTED BOOK	
AREAS CHECKED	

DATE	
BY	
ORIGINAL SURVEY	
NOTED BOOK	
AREAS CHECKED	

MODEL: PRWofRoad
FILE NAME: pzj\prwofroad\paw_bentley.com\afinra-paw\3D Documents\01 Projects\2017\2020\02\25\00 - DOT Phase II Vertical Design\2020\02\25\01.W01.s - Wolf Road over I-80\Drawings\Current Drawing Files\CADD_Drawing\roadway\3D Workspace\112323.svs Wolf Rd Shored.dgn

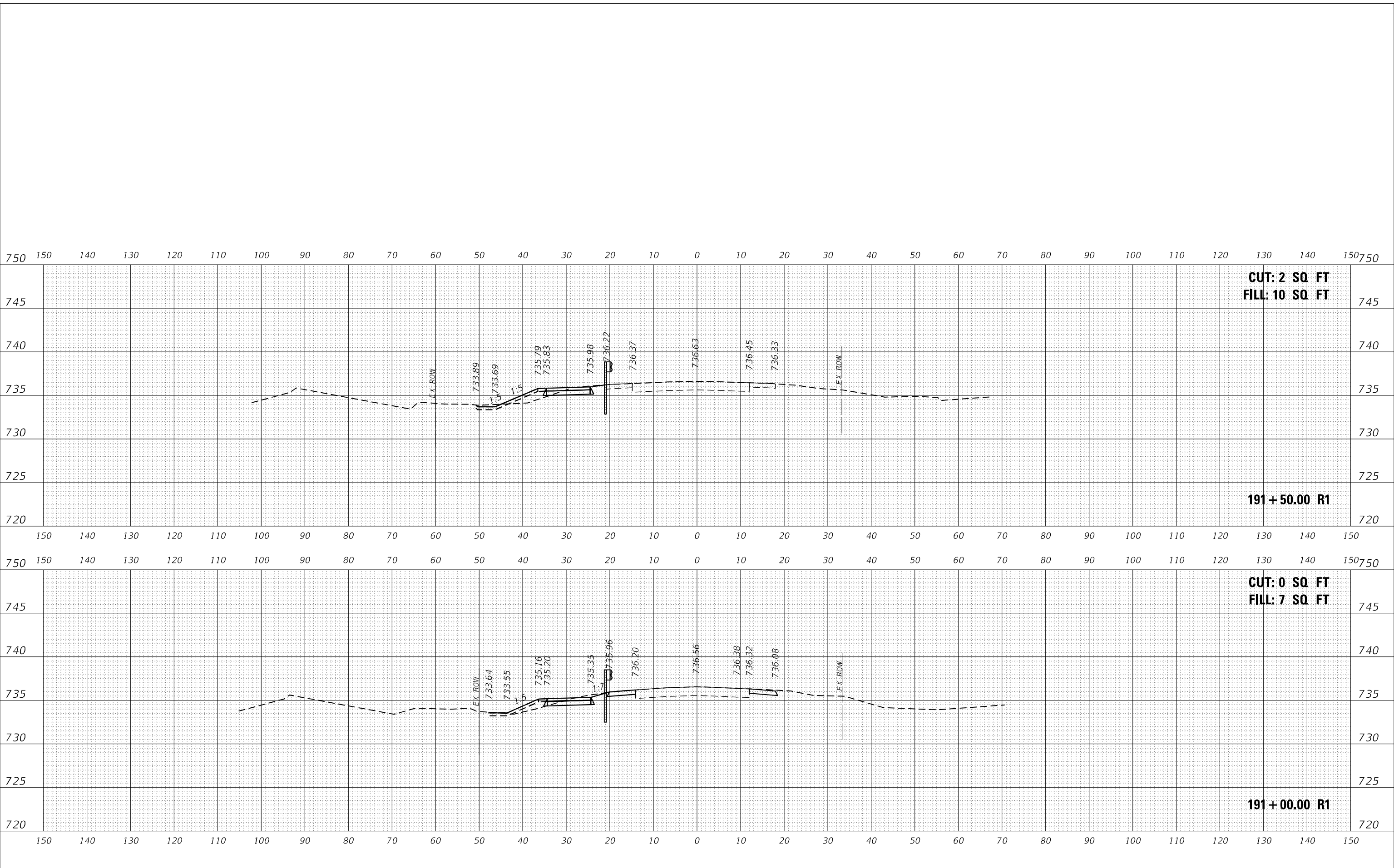

USER NAME = rvandermus	DESIGNED -	REVISED -
	DRAWN -	REVISED -
PLOT SCALE = 20,0012' / in.	CHECKED -	REVISED -
PLOT DATE = 3/10/2022	DATE -	REVISED -

**STATE OF ILLINOIS
DEPARTMENT OF TRANSPORTATION**

**CROSS SECTIONS
WOLF ROAD BRIDGE OVER I-80**

SCALE: SHEET OF SHEETS STA. 191+00.00 R1 TO STA. 191+50.00 R1

F.A.P. RTE.	SECTION	COUNTY	TOTAL SHEETS	SHEET NO.
2688	2020-250-BY	WILL	133	125
				CONTRACT NO. 62N20
		ILLINOIS	FED. AID PROJECT	

FINAL SURVEY	SURVEYED	BY	DATE
NOTE BOOK	PLOTTED		
NO.	TEMPLATE		
	AREAS CHECKED		

ORIGINAL SURVEY	SURVEYED	BY	DATE
NOTE BOOK	PLOTTED		
NO.	TEMPLATE		
	AREAS CHECKED		

MODEL: P:\WolfRoad
 FILE NAME: p:\proj\prj\paw_bentley.com\prj\paw\paw\DOT Phase II Various Design\2020\02-25-00 - DOT Phase II Various Design\2020\02-25-01_WO 1-3 - Wolf Road over I-80\Drawings\Curent Drawing Files\CADD Drawings\ roadway3D Works\paw\01323333\YS Wolf Rd_Shored.dgn

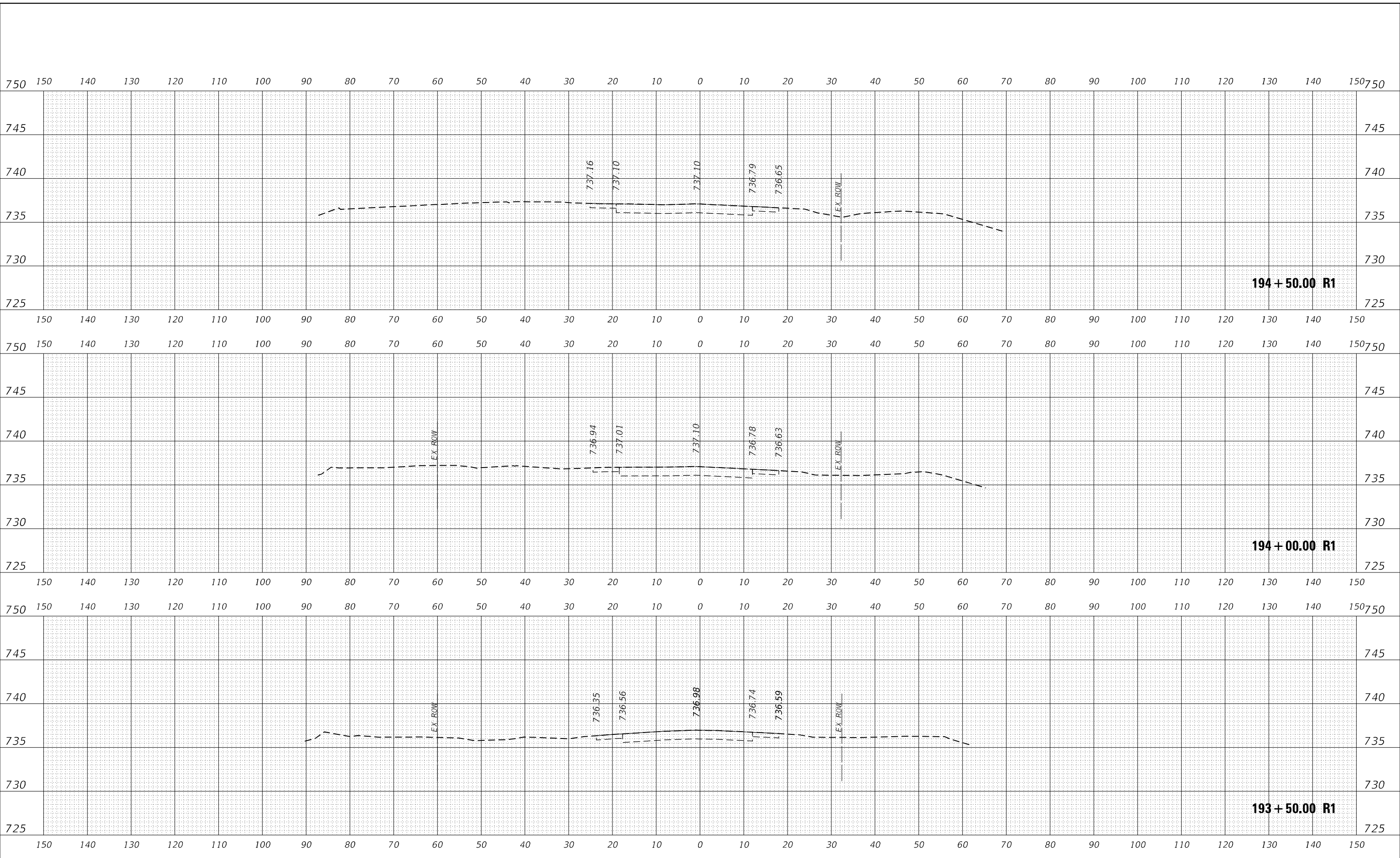

USER NAME = rmarlin	DESIGNED -	REVISED -
	DRAWN -	REVISED -
PLOT SCALE = 20,0012' * / in.	CHECKED -	REVISED -
PLOT DATE = 7/2/2022	DATE -	REVISED -

**STATE OF ILLINOIS
DEPARTMENT OF TRANSPORTATION**

CROSS SECTIONS			
WOLF ROAD BRIDGE OVER I-80			
SCALE:	SHEET	OF	SHEETS
			STA. 193+50.00 R1 TO STA. 194+50.00 R1

F.A.P. RTE.	SECTION	COUNTY	TOTAL SHEETS	SHEET NO.
2688	2020-250-BY	WILL	133	127
				CONTRACT NO. 62N20
ILLINOIS		FED. AID PROJECT		

FINAL SURVEY	SURVEYED	BY	DATE
NOTE BOOK	PLOTTED		
NO.	TEMPLATE		
	AREAS CHECKED		
	AREAS CHECKED		

ORIGINAL SURVEY	SURVEYED	BY	DATE
NOTE BOOK	PLOTTED		
NO.	TEMPLATE		
	AREAS CHECKED		
	AREAS CHECKED		

MODEL: PRWolfRoad
FILE NAME: p:\proj\prns-pw-bentley.com\prns-pw\cadd\Drawings\Wolf Rd. Shoreline.dgn
I:\DOT\Phase II\Various Design\2020\25-01\195+00-195+50.00 - Wolf Road over I-80\Drawings\Curent.dwg
I:\DOT\Phase II\Various Design\2020\25-01\195+00-195+50.00 - Wolf Road over I-80\Drawings\Current.dwg
I:\DOT\Phase II\Various Design\2020\25-01\195+00-195+50.00 - Wolf Road over I-80\Drawings\Current.dwg
I:\DOT\Phase II\Various Design\2020\25-01\195+00-195+50.00 - Wolf Road over I-80\Drawings\Current.dwg

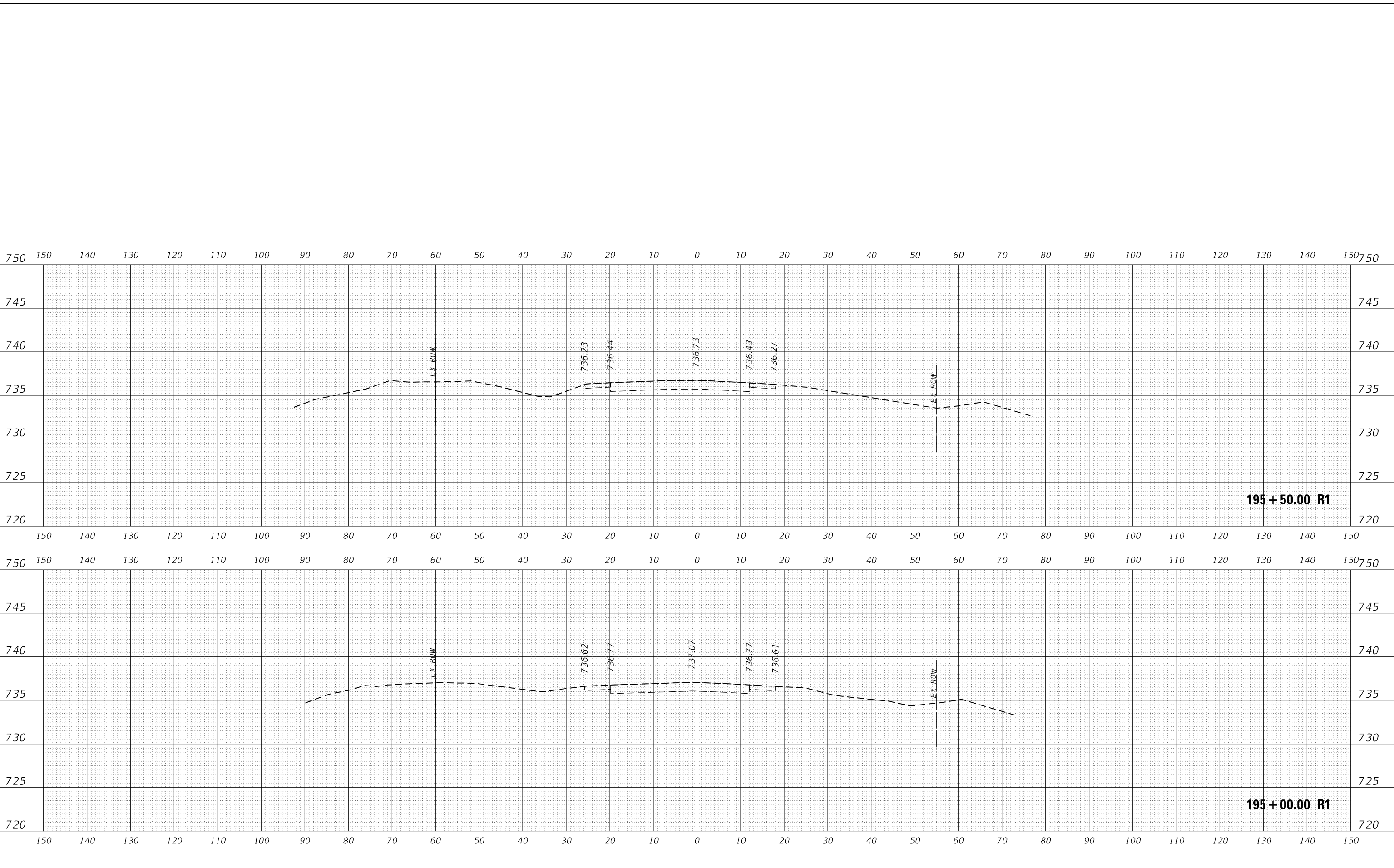

USER NAME = rmarlin	DESIGNED -	REVISED -
	DRAWN -	REVISED -
PLOT SCALE = 20,0012 * / in.	CHECKED -	REVISED -
PLOT DATE = 7/2/2022	DATE -	REVISED -

**STATE OF ILLINOIS
DEPARTMENT OF TRANSPORTATION**

CROSS SECTIONS	
WOLF ROAD BRIDGE OVER I-80	
SCALE:	SHEET OF SHEETS
STA. 195+00.00 R1 TO STA. 195+50.00 R1	

F.A.P. RTE.	SECTION	COUNTY	TOTAL SHEETS	SHEET NO.
2688	2020-250-BY	WILL	133	128
CONTRACT NO. 62N20				
ILLINOIS FED. AID PROJECT				

FINAL SURVEY	NO.
SURVEYED	DATE
PLOTTED	BY
TEMPLATE	
AREAS CHECKED	

ORIGINAL SURVEY	NO.
SURVEYED	DATE
PLOTTED	BY
TEMPLATE	
AREAS CHECKED	

MODEL: PRVWolfRoad
 FILE NAME: p:\proj\prv-rs-pw-bentley.com\at\mra-paw\c0\Documents\01\Projects\2020\2025\00 - DOT Phase II Various Design\2020\25\01_V01-1 - Wolf Road over I-80\Drawings\Curent Drawing Files\CAD\Drawings\toairway3D\Wolfrd_R1_Shared.dgn

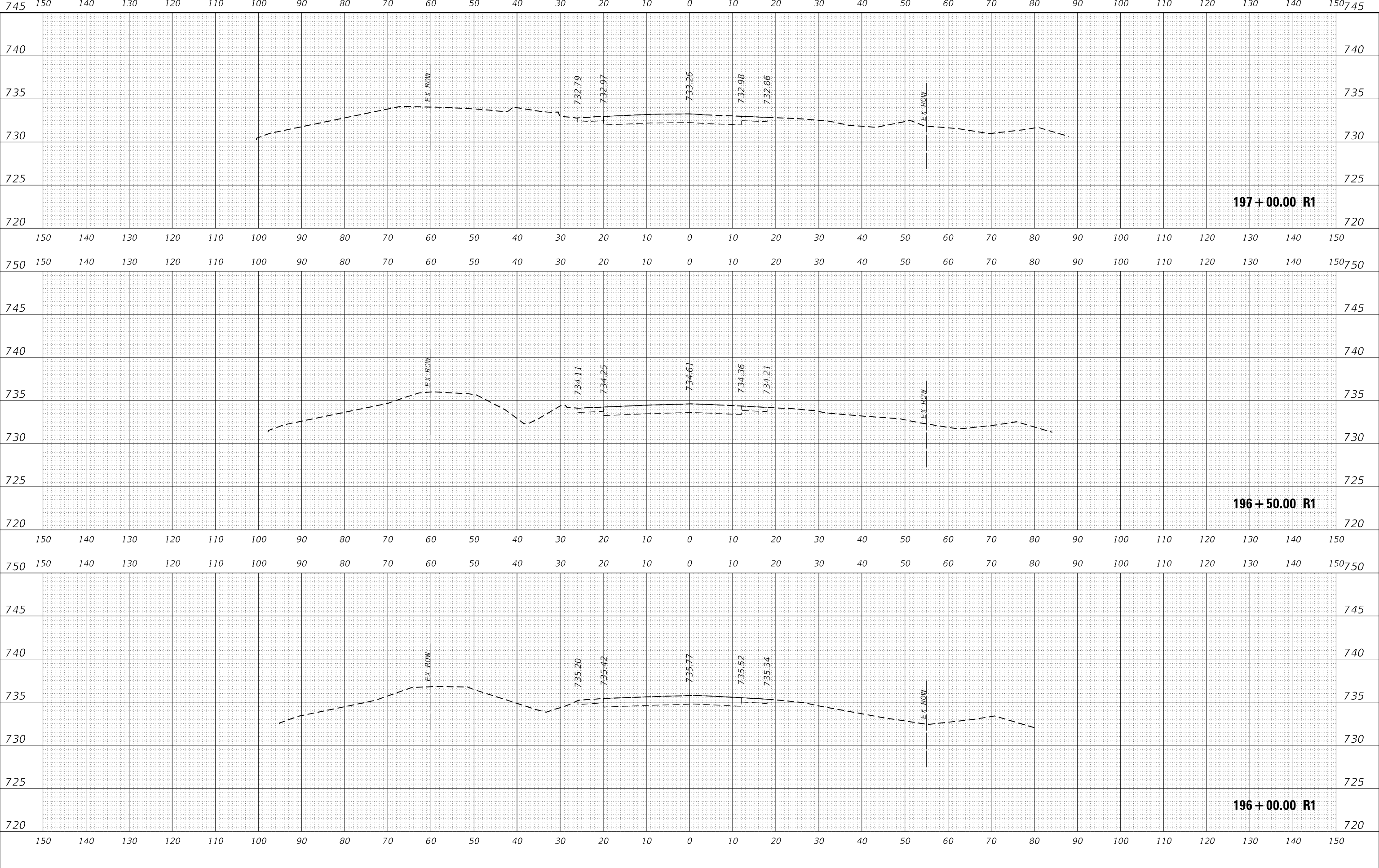

USER NAME = rmarlin	DESIGNED -	REVISED -
	DRAWN -	REVISED -
PLOT SCALE = 20,0012' / in.	CHECKED -	REVISED -
PLOT DATE = 2/2/2022	DATE -	REVISED -

**STATE OF ILLINOIS
DEPARTMENT OF TRANSPORTATION**

CROSS SECTIONS			
WOLF ROAD BRIDGE OVER I-80			
SCALE:	SHEET	OF	SHEETS
			STA. 196+00.00 R1 TO STA. 197+00.00 R1

F.A.P. RTE.	SECTION	COUNTY	TOTAL SHEETS	SHEET NO.
2688	2020-250-BY	WILL	133	129
				CONTRACT NO. 62N20
ILLINOIS		FED. AID PROJECT		

DATE	
BY	
FINAL SURVEY	SURVEYED
NOTE BOOK	PLOTTED
NO.	TEMPLATE
	AREAS CHECKED

MODEL: D:\mfr\it\...
 FILE NAME: D:\mfr\it\...
 PROJECTS: 2020\2020-25\00 - DOT Phase II Various Design\2020-25\01\VO 1-3 - Wolf Road over I-80 Drawings\Current Drawings Files\CAD\Sheets\ roadway\1133-entax\ 1133-entax.rvt

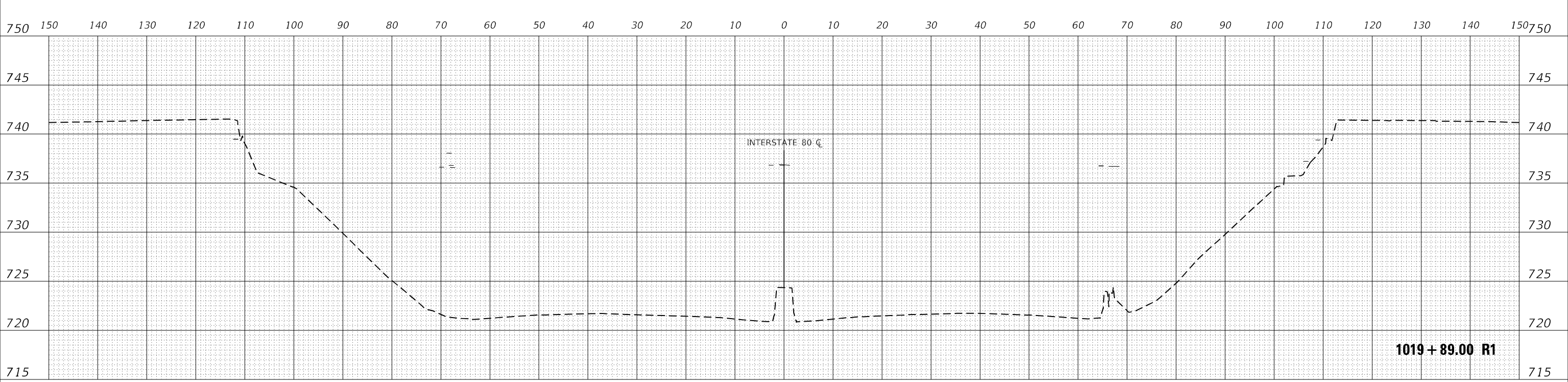

DATE	
BY	
ORIGINAL SURVEY	SURVEYED
NOTE BOOK	PLOTTED
NO.	TEMPLATE
	AREAS CHECKED

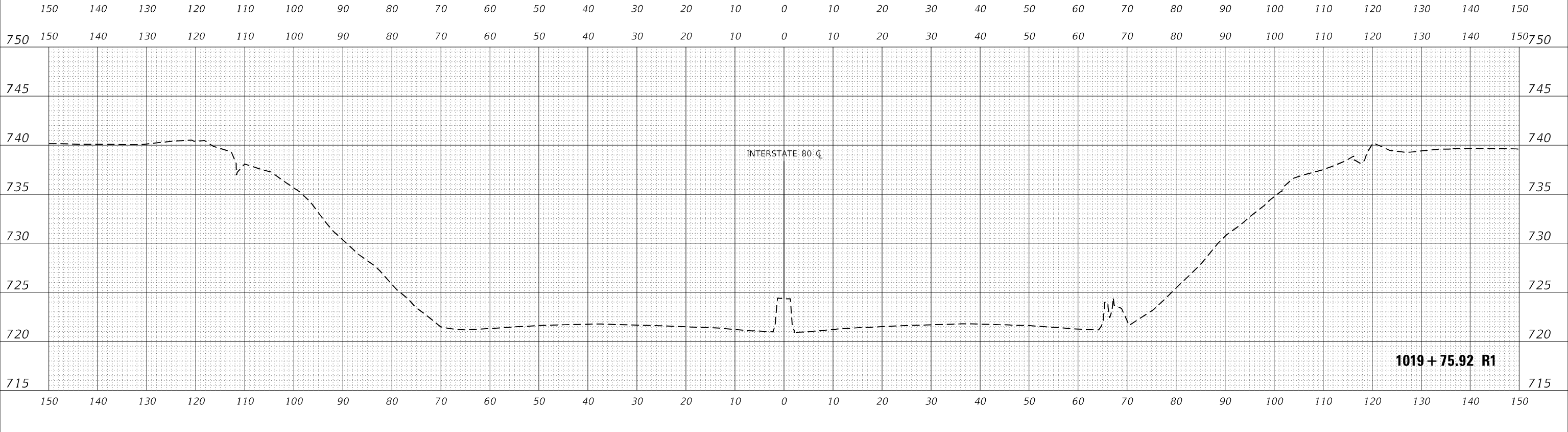

USER NAME = rmarlin	DESIGNED - RM/RMV	REVISED -
	DRAWN - RM/RMV	REVISED -
PLOT SCALE = 2,000' / in.	CHECKED - MPV	REVISED -
PLOT DATE = 2/2/2022	DATE - 07/07/2021	REVISED -

**STATE OF ILLINOIS
DEPARTMENT OF TRANSPORTATION**

I-80 CROSS SECTIONS UNDER WOLF RD.	
STA 1019+75.92 TO STA 1019+89.00	
SCALE:	SHEET OF SHEETS
STA. 1019+75.92 R1 TO STA. 1019+89.00 R1	

F.A. RTE.	SECTION	COUNTY	TOTAL SHEETS	SHEET NO.
2688	2020-250-BY	WILL	133	132
CONTRACT NO. 62N20				
ILLINOIS FED. AID PROJECT				

FINAL SURVEY	SURVEYED	BY	DATE
NOTE BOOK	PLOTTED		
NO.	TEMPLATE		
	AREAS CHECKED		

ORIGINAL SURVEY	SURVEYED	BY	DATE
NOTE BOOK	PLOTTED		
NO.	TEMPLATE		
	AREAS CHECKED		

MODEL: D:\mfr\h... FILE NAME: D:\mfr\mfr-pw-bentley.com\p1mfrs-pw-0\Documents\01\Projects\2020\2020-25-00 - DOT Phase II Various Design\2020-25-01_WO 1-3 - Wolf Road over I-80\Drawings\Current Drawing Files\CAD\Sheets\Stationway\01133-stn-XS-180-02.dgn

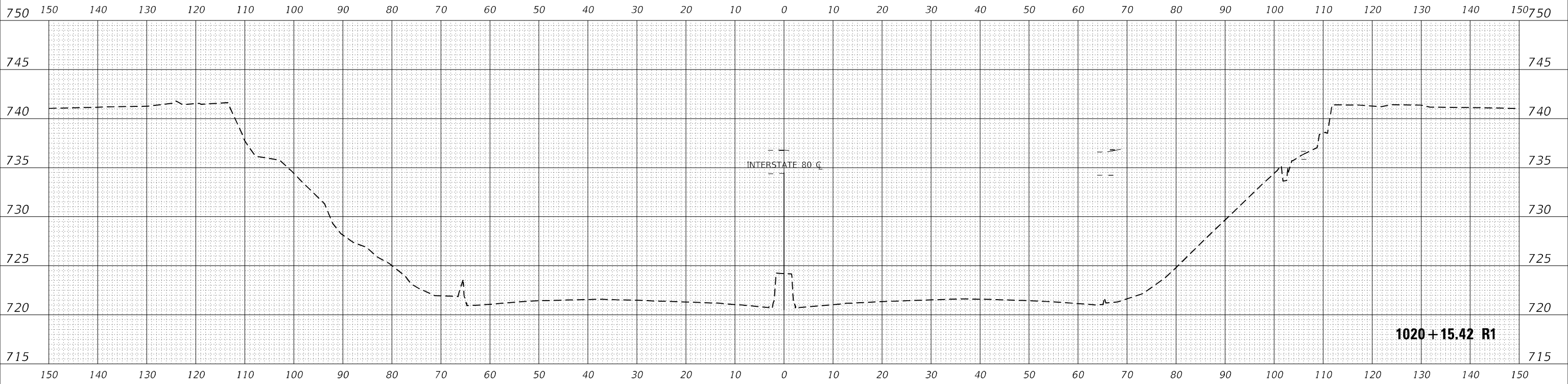

USER NAME = rmartin	DESIGNED - RM/RMV	REVISED -
PLOT SCALE = 2,0000' / in.	DRAWN - RM/RMV	REVISED -
PLOT DATE = 2/2/2022	CHECKED - MPV	REVISED -
	DATE - 07/07/2021	REVISED -

**STATE OF ILLINOIS
DEPARTMENT OF TRANSPORTATION**

I-80 CROSS SECTIONS UNDER WOLF RD.			
STA 1020+15.42			
SCALE:	SHEET	OF	SHEETS
			STA. 1020+15.42 R1 TO STA. 1020+15.42 R1

F.A. RTE.	SECTION	COUNTY	TOTAL SHEETS	SHEET NO.
2688	2020-250-BY	WILL	133	133
CONTRACT NO. 62N20				
ILLINOIS FED. AID PROJECT				