

EXISTING TANGENT SECTION
STA. 317+72 TO STA. 319+72

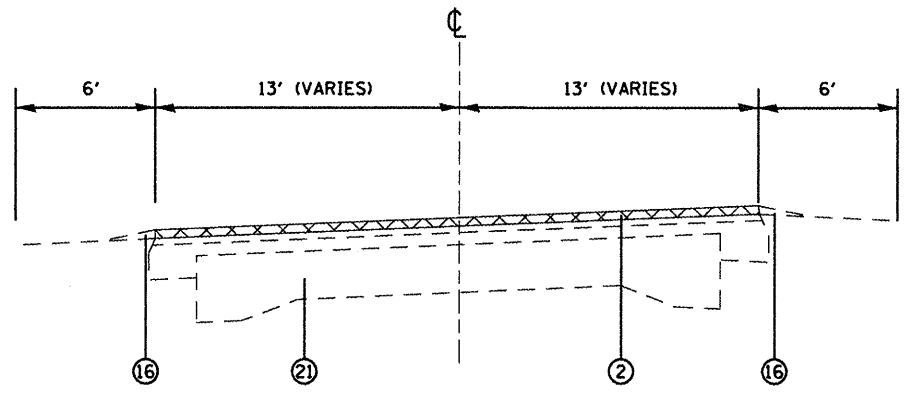

EXISTING SUPERELEVATION TYPICAL SECTION
STA. 412+00.00 TO STA. 429+62.33
STA. 452+22.30 TO STA. 456+89.13

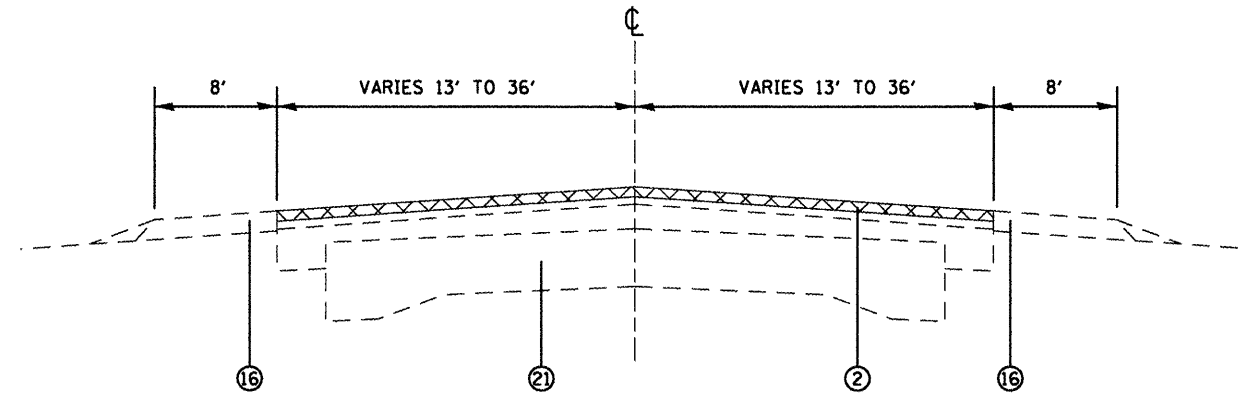

EXISTING TYPICAL SECTION
STA. 402+60 TO STA. 406+73

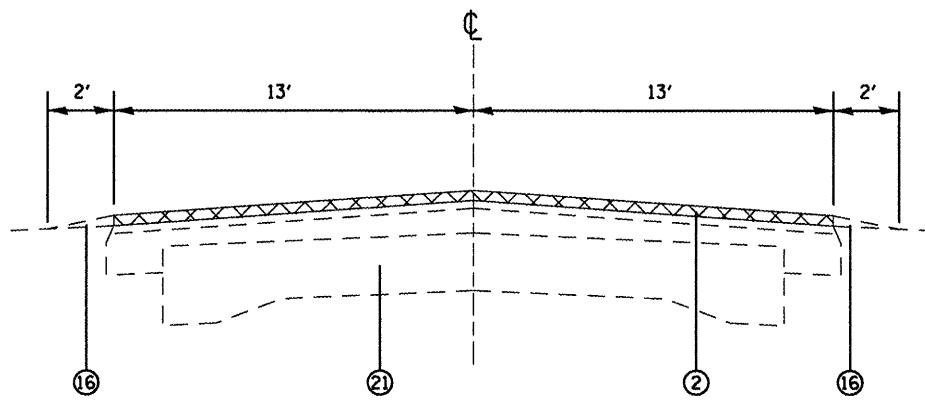

EXISTING TYPICAL SECTION
STA. 319+72.21 TO STA. 329+00.00
STA. 346+00.00 TO STA. 402+60.00
STA. 406+73.00 TO STA. 412+00.00
STA. 429+66.22 TO STA. 452+22.30
STA. 456+89.13 TO STA. 477+44.00

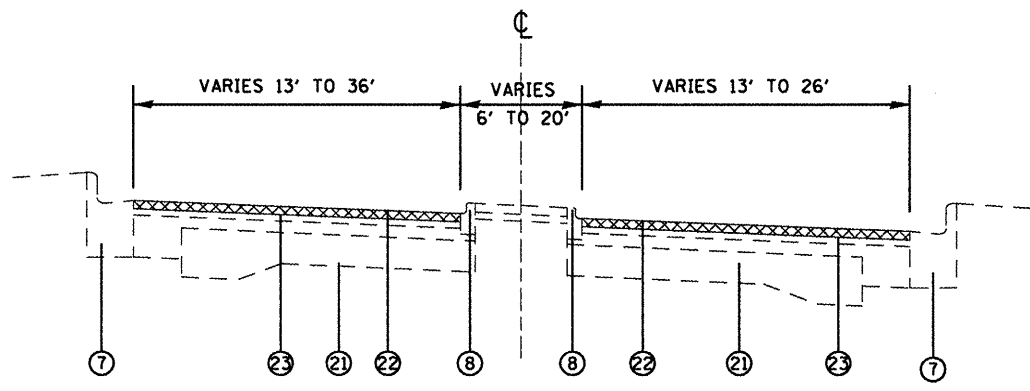

EXISTING SUPERELEVATION TYPICAL SECTION
STA. 329+00 TO STA. 346+00

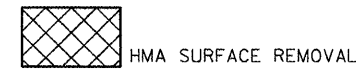

- LEGEND**
- ① EXISTING P.C.C. PAVEMENT 10"
 - ② EXISTING BITUMINOUS SURFACE
 - ③ EXISTING BIT. CONC. SURF. CRSE. MIX "D", CL I, 1 1/4"
 - ④ EXISTING P.C.C. BASE CRSE. 9"
 - ⑤ EXISTING STABILIZED SUB-BASE 4"
 - ⑥ EXISTING BITUMINOUS CONC. BINDER CRSE. 3/4"
 - ⑦ EXISTING COMBINATION C&G, TYP M6.24
 - ⑧ EXISTING COMBINATION C&G, TYP M6.06
 - ⑨ EXISTING COMBINATION C&G, TYP M6.06 (MODIFIED)
 - ⑩ EXISTING CONCRETE MEDIAN SURFACE 4"
 - ⑪ EXISTING CONCRETE MEDIAN, TYPE C 4 (MODIFIED)
 - ⑫ EXISTING CONCRETE MEDIAN, TYPE SM 6.06 (SPECIAL)
 - ⑬ EXISTING SAND BACKFILL
 - ⑭ EXISTING PIPE UNDERDRAIN 4"
 - ⑮ EXISTING BITUMINOUS SHOULDER 8"
 - ⑯ EXISTING AGGREGATE SHOULDER, TYPE B
 - ⑰ EXISTING AGGREGATE BASE COURSE, TYPE A, 12"
 - ⑱ EXISTING BIT. CONC. BASE CRSE. SUPERPAVE, 1 1/2"
 - ⑲ EXISTING LEVELING BINDER CRSE. SUPERPAVE, 3/4"
 - ⑳ EXISTING BIT. CONC. SURFACE CRSE. SUPERPAVE, 1 1/2"
 - ㉑ EXISTING POLYMERIZED HMA SURFACE COURSE, MIX "D", N90, 1 1/2"
 - ㉒ EXISTING LEVELING BINDER (MACHINE METHOD), N90, 3/4"

FILE NAME =	USER NAME = *USER*	DESIGNED - ---	REVISED - ---
FILE#		DRAWN - ---	REVISED - ---
	PLOT SCALE = *SCALE*	CHECKED - ---	REVISED - ---
	PLOT DATE = *DATE*	DATE - ---	REVISED - ---

STATE OF ILLINOIS
DEPARTMENT OF TRANSPORTATION

EXISTING TYPICAL SECTION LOCATION #1	
IL 162 FROM IL 203 TO IL 111	
SCALE: _____	SHEET NO. ___ OF ___ SHEETS STA. _____ TO STA. _____

F.A.P. RTE.	SECTION	COUNTY	TOTAL SHEETS	SHEET NO.
596	5785-4157-1.51185-3	MADISON	33	8
CONTRACT NO. 76E49				
FED. ROAD DIST. NO. _____ ILLINOIS FED. AID PROJECT				