

**PLAN**  
(For skews  $\le 30^\circ$ )

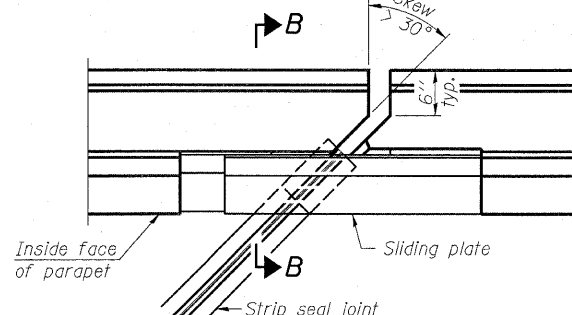

**PLAN**  
(For skews  $> 30^\circ$ )  
Showing point block

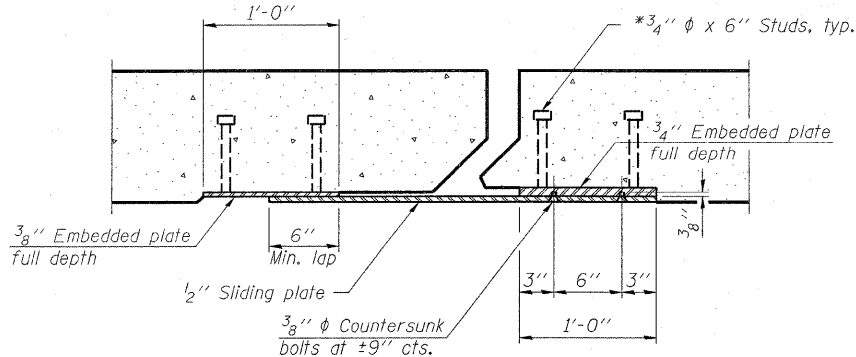

**SECTION C-C**

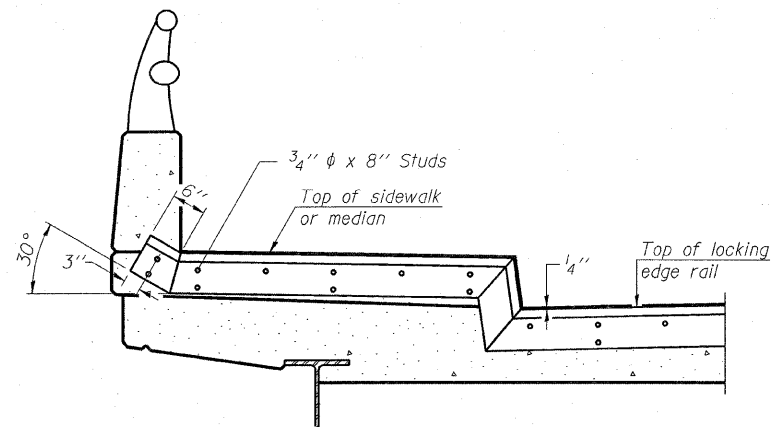

**TYPICAL END TREATMENT AT SIDEWALK OR MEDIAN**

Shorter plates with a single row of studs at 12" cts. may be necessary on medians which are shallower than 9". See manufacturer's recommendation.

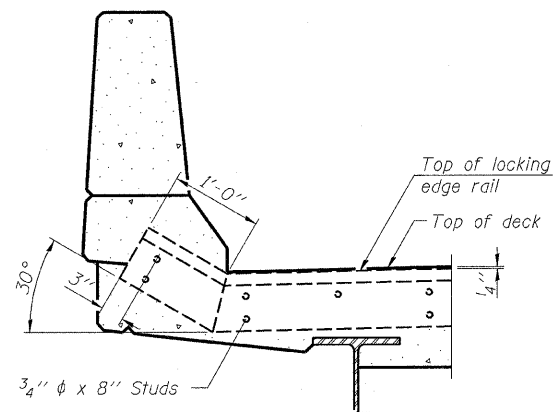

**SECTION A-A**

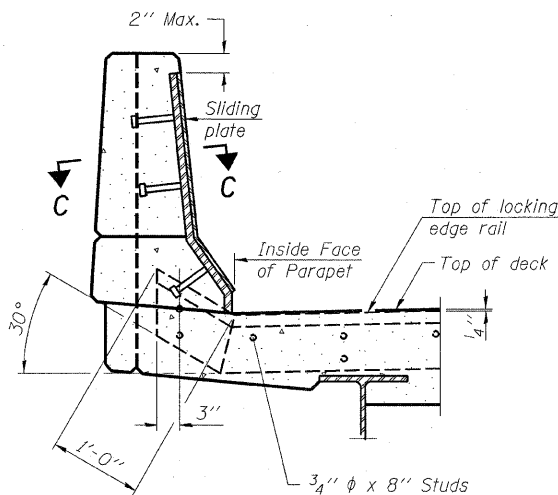

**SECTION B-B**

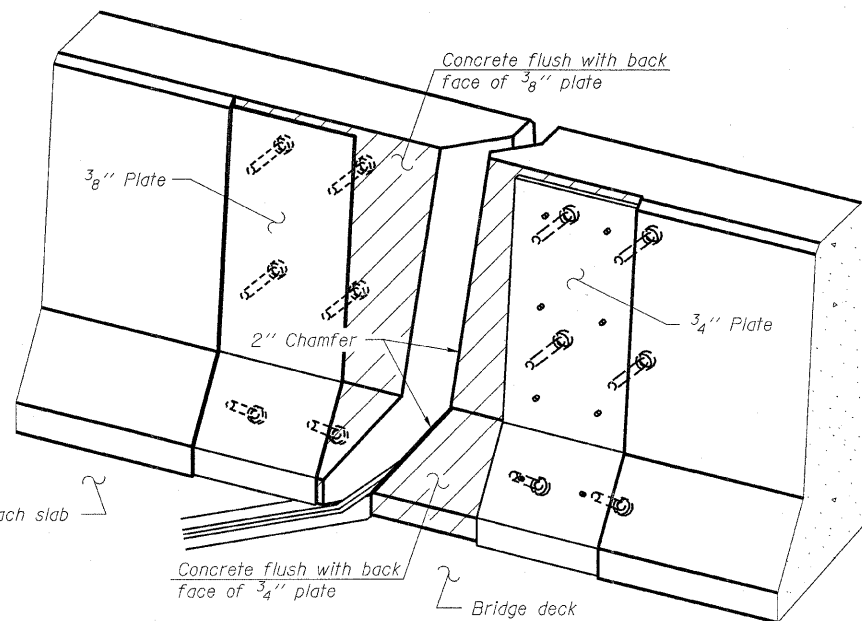

**TRIMETRIC VIEW**  
(Showing back plates only)

**Notes:**

The strip seal shall be made continuous and shall have a minimum thickness of 1/4". The configuration of the strip seal shall match the configuration of the Locking Edge Rails. Open or "webbed" strip seal gland configurations are not permitted. The gland shall be sized for a maximum rated movement of 4 inches.

The Locking Edge Rails depicted are conceptual only, except for the minimum dimensions shown. The actual configuration of the Locking Edge Rails and matching strip seal may vary from manufacturer to manufacturer. Flanged edge rails will not be allowed. Locking Edge Rails may be spliced at slope discontinuities.

The manufacturer's recommended installation methods shall be followed.

The joint opening and deck dimensions detailed on the superstructure are based on a rolled rail expansion joint. If the Contractor elects to use the welded rail expansion joint, the opening and deck dimensions shall be modified according to the dimensions detailed on this sheet. Required modifications shall be made at no additional cost to the State.

All steel components shall be galvanized after fabrication according to Article 520.03 of the Standard Specifications.

Maximum space between rail segments at stage lines shall be 3/16", sealed with a suitable sealant.

Parapet plates and anchorage studs for skews  $> 30^\circ$  included in the cost of Preformed Joint Strip Seal.

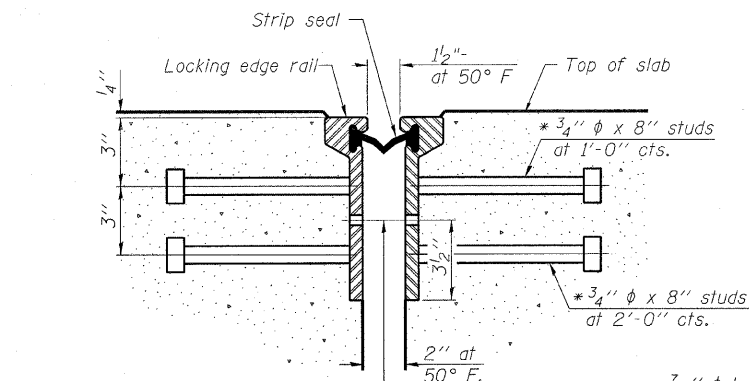

**SECTION THRU ROLLED RAIL JOINT**

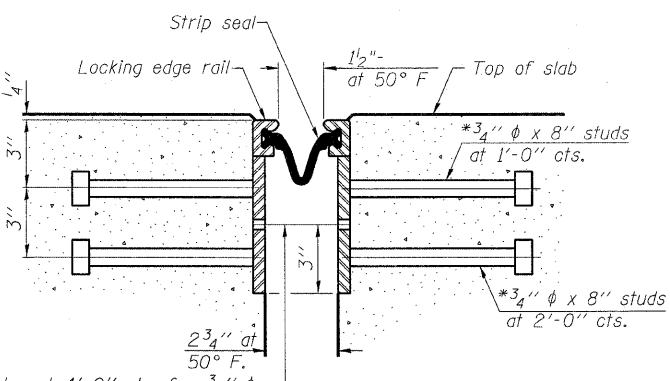

**SECTION THRU WELDED RAIL JOINT**

7/16"  $\phi$  holes at 4'-0" cts. for 3/8"  $\phi$  bolts. All bolts shall be burned, sawed, or chipped off flush with the plates after forms are removed, typ.

7/16"  $\phi$  holes at 4'-0" cts. for 3/8"  $\phi$  bolts. All bolts shall be burned, sawed, or chipped off flush with the plates after forms are removed, typ.

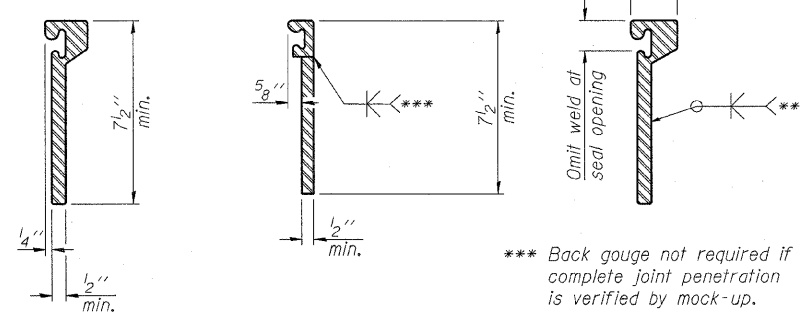

**ROLLED EXTRUDED RAIL**

**WELDED RAIL**

**LOCKING EDGE RAIL SPLICE**

The inside of the locking edge rail groove shall be free of weld residue.

Rolled rail shown, welded rail similar.

\*\*\* Back gouge not required if complete joint penetration is verified by mock-up.

**LOCKING EDGE RAILS**

**BILL OF MATERIAL**

Item	Unit	Total
Preformed Joint Strip Seal	Foot	98.0

\* Granular or solid flux filled headed studs conforming to Article 1006.32 of the Std. Specs., automatically end welded.

EJ-SSJ

7-1-10

FILE NAME =	USER NAME = swartzrw	DESIGNED KLB	REVISED -
c:\pv_work\p\dot\swartzrw\d0207669\077	482-sht-brdeta1s-0800005.dgn	DRAWN KLB	REVISED -
PLOT SCALE = 28.0000 "/ IN.	CHECKED MEA	DATE 12/6/2010	REVISED -
PLOT DATE = 1/27/2011			

**STATE OF ILLINOIS DEPARTMENT OF TRANSPORTATION**

**PREFORMED JOINT STRIP SEAL STRUCTURE NO. 080-0005**

SCALE: NA SHEET NO. 9 OF 13 SHEETS STA. TO STA.

\*5-2VB-1,5-2HB,5-2VB-2IBR-2

F.A.P. RTE.	SECTION	COUNTY	TOTAL SHEETS	SHEET NO.
327	.	Richland	53	45
			CONTRACT NO. 74482	
ILLINOIS FED. AID PROJECT				