

**OPTION 1**

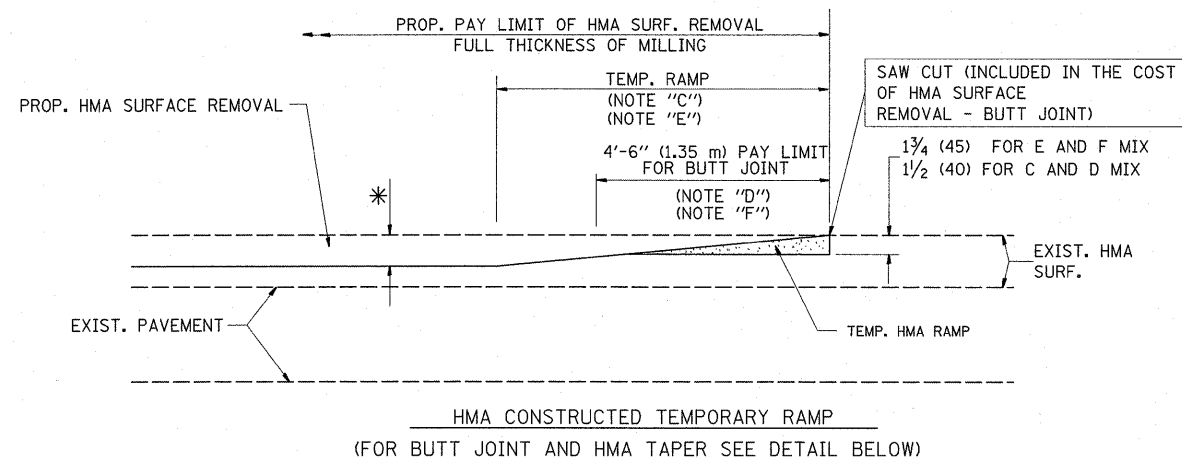

**OPTION 2**  
**TYPICAL TEMPORARY RAMP**

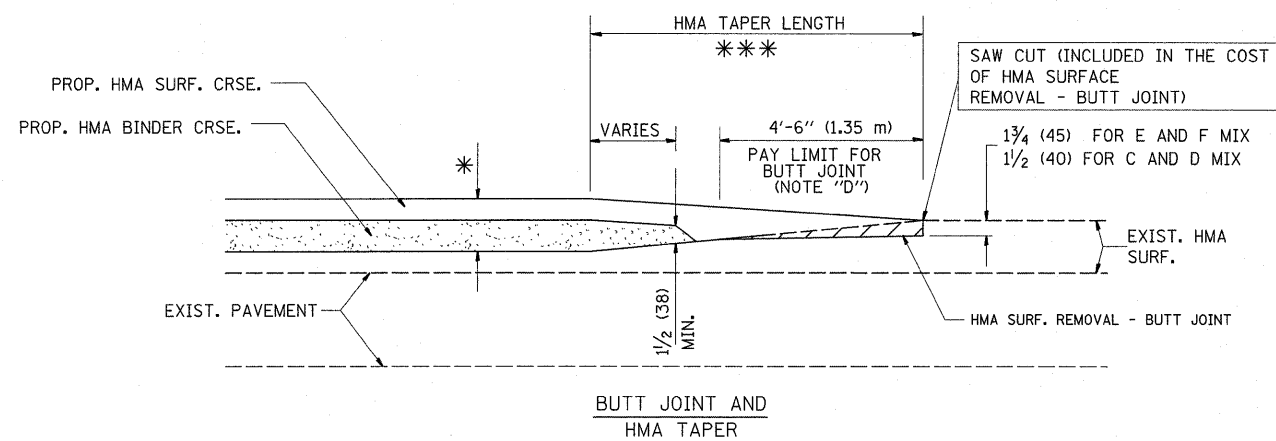

**TYPICAL BUTT JOINT AND HMA TAPER FOR MILLING AND RESURFACING**

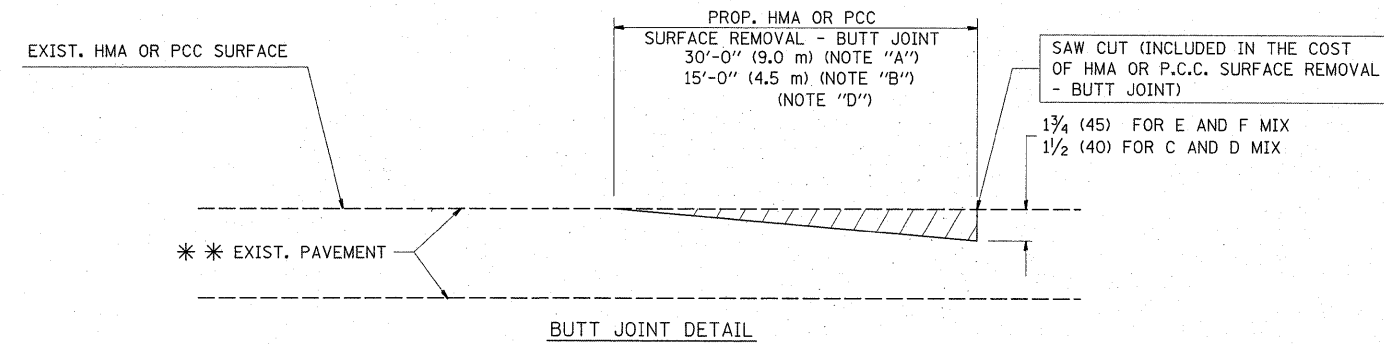

**BUTT JOINT DETAIL**

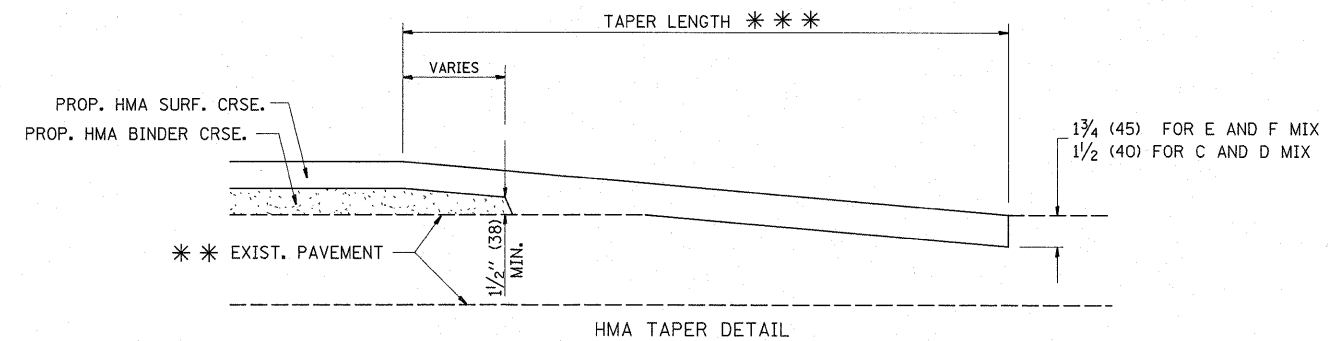

**HMA TAPER DETAIL**

**TYPICAL BUTT JOINT AND HMA TAPER FOR RESURFACING ONLY**

\*\*\* PC CONCRETE, HMA OR HMA RESURFACED PAVEMENT.

**NOTES**

- A: MAINLINE ROADWAYS AND MAJOR SIDE ROADS.
  - B: MINOR SIDE ROADS.
  - C: THE TEMP. RAMP SHALL BE CONSTRUCTED IMMEDIATELY UPON REMOVAL OF THE EXISTING HMA SURFACE.
  - D: THE BUTT JOINT SHALL BE CONSTRUCTED IMMEDIATELY PRIOR TO PLACING THE PROPOSED HMA COURSES.
  - E: TAPER THE TEMP. RAMP AT A RATE OF 3'-0" (900 mm) PER 1 INCH (25 mm) OF MILLING THICKNESS.
  - F: INSTALLATION AND REMOVAL OF THE 4'-6" (1.35 m) TEMP. RAMP IS INCLUDED IN COST OF HMA SURFACE REMOVAL - BUTT JOINT
  - G: SEE ARTICLE 406.08 AND 406.14 OF THE STANDARD SPECIFICATIONS FOR "HMA AND/OR PCC SURFACE REMOVAL, BUTT JOINT".
- \* SEE TYPICAL SECTIONS FOR MILLING THICKNESS.
- \*\*\* 20'-0" (6.1 m) PER 1 (25) RESURFACING (NOTE "A")  
10'-0" (3.0 m) PER 1 (25) RESURFACING (NOTE "B")

**BASIS OF PAYMENT:**

THE BUTT JOINT WILL BE PAID FOR AT THE CONTRACT UNIT PRICE PER SQUARE YARD (SQUARE METER) FOR "HOT-MIX ASPHALT SURFACE REMOVAL - BUTT JOINT" OR FOR "PORTLAND CEMENT CONCRETE SURFACE REMOVAL - BUTT JOINT".

ALL DIMENSIONS ARE IN INCHES (MILLIMETERS) UNLESS OTHERWISE SHOWN.

|                                     |                        |                             |                             |
|-------------------------------------|------------------------|-----------------------------|-----------------------------|
| FILE NAME =                         | USER NAME = pcc1echeal | DESIGNED - M. DE YONG       | REVISED - R. SHAH 10-25-94  |
| cr:\pw\work\pcc1echeal\d0187931\Dis | Std.dgn                | DRAWN -                     | REVISED - A. ABBAS 03-21-97 |
| PLOT SCALE = 50.0000' / IN.         | CHECKED -              | REVISED - M. GOMEZ 04-06-01 |                             |
| PLOT DATE = 2/1/2011                | DATE - 06-13-90        | REVISED - R. BORO 01-01-07  |                             |

**STATE OF ILLINOIS**  
**DEPARTMENT OF TRANSPORTATION**

**BUTT JOINT AND**  
**HMA TAPER DETAILS**

|   |            |        |                    |           |
|---|------------|--------|--------------------|-----------|
| F.A.P. RTE.   | SECTION    | COUNTY | TOTAL SHEETS       | SHEET NO. |
| 344   | 525-2-RS-1 | COOK   | 19                 | 11        |
| BD400-05 BD32                                       |            |        | CONTRACT NO. 60K60 |           |
| FED. ROAD DIST. NO. 1   ILLINOIS   FED. AID PROJECT |            |        |                    |           |

SCALE: NONE SHEET NO. 1 OF 1 SHEETS STA. TO STA.