

ALIGNMENT DATA
REHABILITATE FRONTAGE APRON PAVEMENT

LOCATION	DESCRIPTION	STATION	STATE PLANE COORDINATES	
			NORTHING	EASTING
HANGAR FRONTAGE	BEGINNING OF ALIGNMENT 900	900+00	1883774.90	2492758.42
	END OF ALIGNMENT 900	905+00	1883779.72	2493258.40

EARTHWORK QUANTITIES

	VOLUME (C.Y.)
UNCLASSIFIED CUT ITEM AR152410	= 2460.0
TOPSOIL (FROM OFF SITE) ITEM AR9D5520	= 75.0

NOTE:
EARTHWORK QUANTITIES FOR REHABILITATE FRONTAGE APRON PAVEMENT ONLY. FOR OVERLAY TAXWAYS B, D AND E EARTHWORK QUANTITIES, SEE RESPECTIVE STAKING PLAN.



815 Commerce Drive Suite 200
Oak Brook, Illinois 60523
Telephone: 630.990.3800
Fax: 630.990.3801



CITY OF DIXON, ILLINOIS
Post Office Box 386
Dixon, Illinois 61021
Telephone: 815.288.1485

DIXON MUNICIPAL AIRPORT
CHARLES R. WALGREEN FIELD

OVERLAY TAXWAYS B, D AND E
REHABILITATE FRONTAGE APRON PAVEMENT

AIP PROJECT NO. 3-17-0036-B7
IDA PROJECT NO. C73-3436

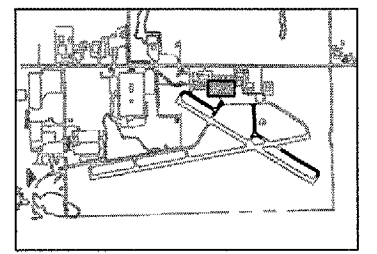

KEY PLAN

LEGEND

- EXISTING CROP LINE
- EXISTING STORM SEWER
- EXISTING SWALE
- EXISTING UNDERDRAIN
- EXISTING FENCE
- EXISTING TRENCH DRAIN
- EXISTING STORM SEWER MANHOLE
- EXISTING UNDERDRAIN CLEANOUT
- PROP. STATION; OFFSET
- PROPOSED GRADING LIMITS
- PROPOSED SWALE
- PROPOSED STORM SEWER
- PROPOSED UNDERDRAIN
- PROPOSED STORM SEWER MANHOLE
- PROPOSED UNDERDRAIN CLEANOUT

NOTES:

1. ALIGNMENT IS BASED ON STATE PLANE COORDINATES (ILLINOIS-WEST). SEE ALIGNMENT DATA TABLE, THIS SHEET.
2. FOR ADDITIONAL GRADING INFORMATION, SEE PLAN SHEET.
3. FOR ADDITIONAL STORM SEWER AND UNDERDRAIN INFORMATION, SEE SCHEDULES.
4. CONTRACTOR IS REQUIRED TO FIELD VERIFY EXISTING UTILITY LOCATIONS.
5. PROPOSED GRADES FOR PAVEMENT ADJACENT TO EXISTING PAVEMENT ARE SHOWN FOR INFORMATION. LOCATIONS WHERE EXISTING GRADES ARE SHOWN AS "M.E." ON THE PLANS SHALL MATCH EXISTING GRADES. IF A CONFLICT ARISES BETWEEN THE PLAN AND THE INSITU CONDITIONS, THE RESIDENT ENGINEER IS TO BE NOTIFIED AND WILL ADJUST ANY GRADES AS NECESSARY.
6. CONTRACTOR WILL BE PROVIDED WITH CONTROL POINTS AND BASELINES IN ACCORDANCE WITH THE SPECIAL PROVISIONS.
7. EXCESS UNCLASSIFIED EXCAVATION IS TO BE DISPOSED OF AT AN OFFSITE LOCATION. COST INCIDENTAL TO ITEM AR152410.
8. FOR SEEDING INFORMATION, SEE LANDSCAPING PLAN.
9. FOR TAXIWAY OVERLAY STAKING INFORMATION, SEE SHEETS 24-33.

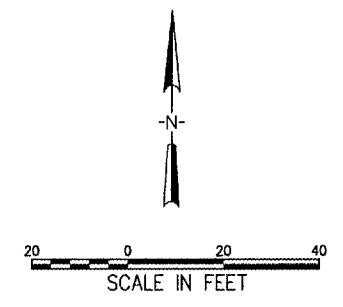

P:\04\025\0204\0468007\DRAWINGS\SHEETS\50-STAKING - FRONTAGE APPROX MAR 17, 2005 10:25AM KLK

No.	Drawing Issue Description	Date	By

Date
11 MARCH 2005

Sheet Title

STAKING PLAN - FRONTAGE APRON

843-04B8007	
Project Number	KLK 02/03/05
LAYOUT BY	KLK, TMM 02/03/05
DESIGNED BY	RMH 03/11/05
REVIEWED BY	KLK DSY ---
DRAWN BY	Sheet No.

50