

F.A.S. RTE.	SECTION	COUNTY	TOTAL SHEETS	SHEET NO.
340	(109,110)PP	IROQUOIS	9	1
		ILLINOIS	CONTRACT NO. 66M45	

INDEX OF SHEETS

1. COVER SHEET
2. GENERAL NOTES
3. SUMMARY OF QUANTITIES
4. TYPICAL SECTION
- 5-6. SCHEDULES
- 7-8. CLASS B PAVEMENT PATCHING DETAILS
9. TEMPORARY INFORMATION SIGNING

HIGHWAY STANDARDS

- | | |
|-----------|--|
| 000001-08 | STANDARD SYMBOLS, ABBREVIATIONS AND PATTERNS |
| 001001-02 | AREAS OF REINFORCEMENT BARS |
| 001006 | DECIMAL OF AN INCH AND OF A FOOT |
| 701001-02 | OFF-ROAD OPERATIONS 2L, 2W, MORE THAN 15' (4.5 m) AWAY |
| 701006-05 | OFF-ROAD OPERATIONS 2L, 2W, 15' (4.5 m) TO 24" (600 mm) FROM PAVEMENT EDGE |
| 701301-04 | LANE CLOSURE, 2L, 2W, SHORT TIME OPERATIONS |
| 701336-07 | LANE CLOSURE, 2L, 2W, WORK AREAS IN SERIES, FOR SPEEDS ≥ 45 MPH |
| 701901-08 | TRAFFIC CONTROL DEVICES |

PROPOSED HIGHWAY PLANS

F.A. P. ROUTE 340 (IL 115) SECTION (109,110)PP CLASS B PAVEMENT PATCHING FORD COUNTY

C-93-071-22

BEGIN IMPROVEMENT

INTERSECTION OF
IL 115 AND IL 54 (S)
IN ROBERTS
LOG MILE. 0.00

END IMPROVEMENT
INTERSECTION OF
IL 115 AND IL 9
LOG MILE 10.57

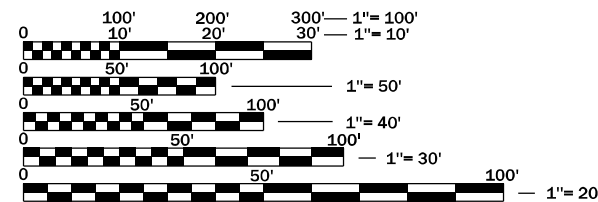

FULL SIZE PLANS HAVE BEEN PREPARED USING STANDARD ENGINEERING SCALES. REDUCED SIZED PLANS WILL NOT CONFORM TO STANDARD SCALES. IN MAKING MEASUREMENTS ON REDUCED PLANS, THE ABOVE SCALES MAY BE USED.

J.U.L.I.E.
JOINT UTILITY LOCATION INFORMATION FOR EXCAVATION
1-800-892-0123
OR 811

PROJECT ENGINEER YOGESH PATEL P.E.
UNIT CHIEF RON WOODSHANK
DISTRICT 3 NO. (815) 434-6131
CONTRACT NO. 66M45

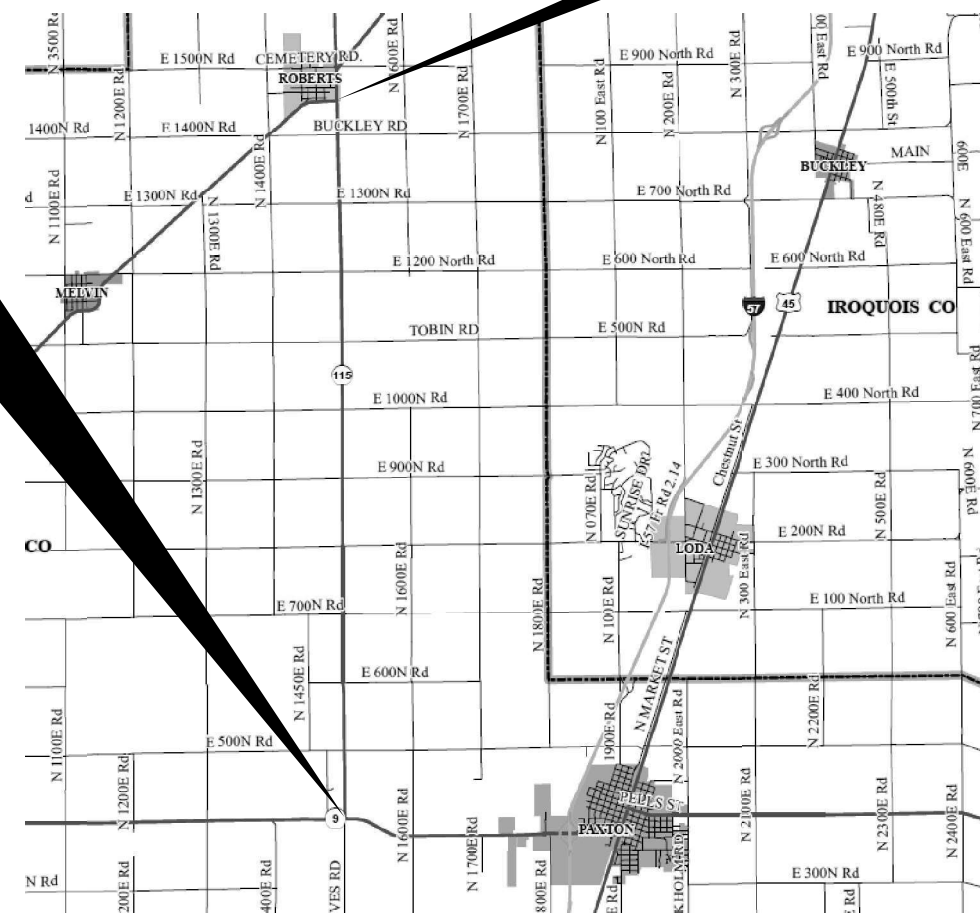

GROSS LENGTH = 55,809 FT. = 10.57 MILES
NET LENGTH = 667 FT. = 0.13 MILES

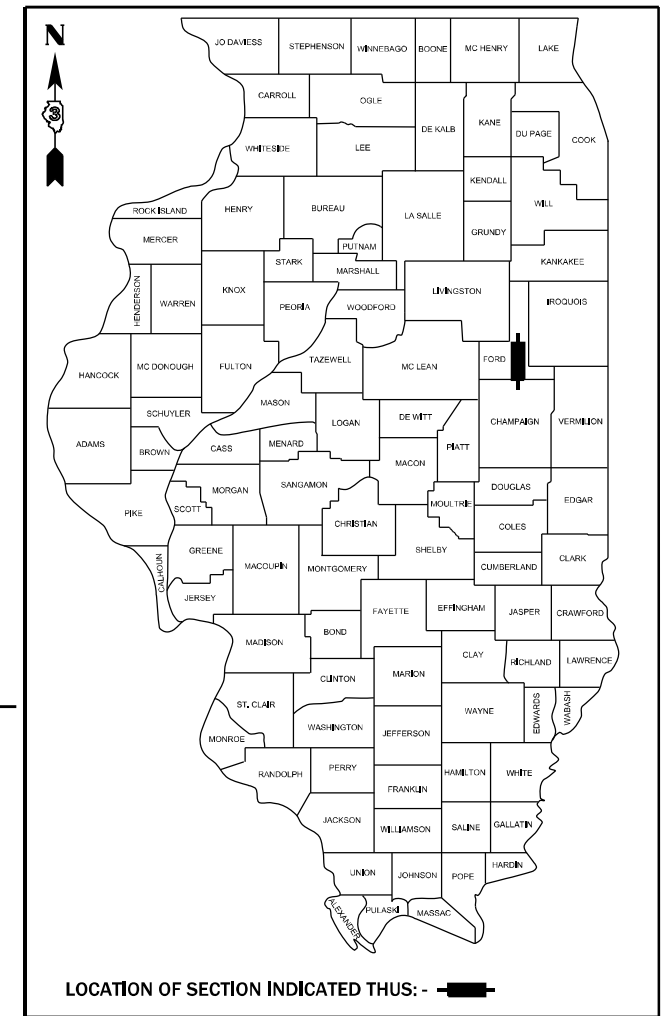

LOCATION OF SECTION INDICATED THIS: - [Symbol]

FUNTIONAL CLASSIFICATION

RURAL MAJOR COLLECTOR
F.A.S. ROUTE 340 (IL 115)
2019 ADT = 900
P.V. 89.9% S.U. 4.6% M.U. 5.5%

STATE OF ILLINOIS
DEPARTMENT OF TRANSPORTATION

SUBMITTED January 31, 2022
David Almond
REGIONAL ENGINEER

March 24, 2023
John A. Etkin
ENGINEER OF DESIGN AND ENVIRONMENT

March 24, 2023
Stephen M. Smith
DIRECTOR OF HIGHWAYS PROJECT IMPLEMENTATION

**PRINTED BY THE AUTHORITY
OF THE STATE OF ILLINOIS**

GENERAL NOTES

PLAN DIMENSIONS AND DETAILS RELATIVE TO EXISTING PLANS ARE SUBJECT TO NOMINAL CONSTRUCTION VARIATIONS. THE CONTRACTOR SHALL FIELD VERIFY EXISTING DIMENSIONS AND DETAILS AFFECTING NEW CONSTRUCTION AND MAKE NECESSARY APPROVED ADJUSTMENTS PRIOR TO CONSTRUCTION OR ORDERING OF MATERIALS. SUCH VARIATIONS SHALL NOT BE CAUSE FOR ADDITIONAL COMPENSATION FOR A CHANGE IN SCOPE OF WORK; HOWEVER, THE CONTRACTOR WILL BE PAID FOR THE QUANTITY ACTUALLY FURNISHED AT THE UNIT PRICE BID FOR THE WORK.

ALL EXCAVATED MATERIAL, WHICH INCLUDES DIGGING OR GRADING OF ANY SOIL OR FILL MATERIAL, WITH THE EXCEPTION OF AGGREGATE FILLS, MUST BE INCORPORATED WITHIN THE IDOT RIGHT OF WAY.

THE CONTRACTOR SHALL CONTACT JULIE AT LEAST 48 HOURS PRIOR TO EXCAVATION TO DETERMINE WHICH UTILITIES ARE IN THE AREA.

COMMITMENTS

STATE OF ILLINOIS
DEPARTMENT OF TRANSPORTATION
DISTRICT THREE
AS BUILT INFORMATION

SUPERVISING CONSTRUCTION FIELD ENGINEER

RESIDENT ENGINEER / TECHNICIAN

START & END DATES
OF CONSTRUCTION:

INSPECTORS:

STATE OF ILLINOIS
DEPARTMENT OF TRANSPORTATION
DISTRICT THREE

PREPARED BY: _____
DISTRICT STUDIES & PLANS ENGINEER

DATE: _____

EXAMINED BY: _____
DISTRICT CONSTRUCTION ENGINEER

DISTRICT MATERIALS ENGINEER

DISTRICT OPERATIONS ENGINEER

FILE NAME =	USER NAME = woodshank1	DESIGNED - EVAN MARINI	REVISED -
pw:\idot\pw\berkeley.com\PWIDOT\Documents\IDOT Office\District 3\Projects\I386M43\CADData\I386M43 - PLANS.dgn		DRAWN - EVAN MARINI	REVISED -
Default	PLOT SCALE = 100,0000' / in.	CHECKED - RON WOODSHANK	REVISED -
	PLOT DATE = 1/25/2022	DATE - 1/22/2019	REVISED -

**STATE OF ILLINOIS
DEPARTMENT OF TRANSPORTATION**

GENERAL NOTES

SCALE: SHEET 1 OF 1 SHEETS STA. TO STA.

F.A.S RTE.	SECTION	COUNTY	TOTAL SHEETS	SHEET NO.
340	(109,110)PP	IROQUOIS	9	2
CONTRACT NO. 66M45				
		ILLINOIS	FED. AID PROJECT	

CODE NO.	ITEM	UNIT	TOTAL QUANTITY	CONSTRUCTION CODE	
				CONTRACT MAINTENANCE 100% STATE	ROADWAY
				0006	
					RURAL
44200050	WELDED WIRE REINFORCEMENT	SQ YD	152		152
44201019	CLASS B PATCHES, TYPE II, 14 INCH	SQ YD	912		912
44201023	CLASS B PATCHES, TYPE III, 14 INCH	SQ YD	152		152
44201299	DOWEL BARS 1 1/2"	EACH	2240		2240
44213200	SAW CUTS	FOOT	5628		5628
67100100	MOBILIZATION	L SUM	1		1
70100600	TRAFFIC CONTROL AND PROTECTION, STANDARD 701336	L SUM	1		1
Z0030850	TEMPORARY INFORMATION SIGNING	SQ FT	42		42

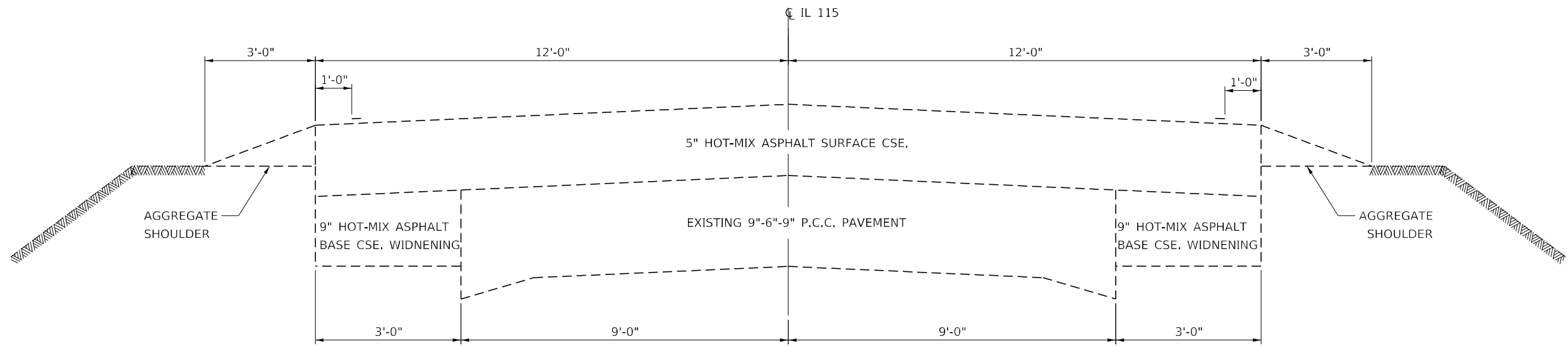

TYPICAL SECTION
LOG MILE 0.00 TO LOG MILE 10.57

FILE NAME =	USER NAME = woodshank1	DESIGNED - EVAN MARINI	REVISED -	STATE OF ILLINOIS DEPARTMENT OF TRANSPORTATION	TYPICAL SECTIONS			F.A.S RTE.	SECTION	COUNTY	TOTAL SHEETS	SHEET NO.
pw:\ildot\pw.bentley.com\PWIDOT\Documents\IDOT Office\District 3\Projects\6366M45\CADData\6366M45-PLANS.dgn		DRAWN - EVAN MARINI	REVISED -		340	(109,110)PP	IROQUOIS	9	4			
Default		CHECKED - RON WOODSHANK	REVISED -		SCALE: SHEET 1 OF 1 SHEETS STA. TO STA.			CONTRACT NO. 66M45				
		DATE - 1/22/2019	REVISED -					ILLINOIS FED. AID PROJECT				

PATCHING SCHEDULE

SOUTHBOUND LANE						
LOCATION	PATCH LENGTH	CLASS B		DOWEL BARS 1 1/2"	SAW CUTS	WELDED WIRE REINFORCEMENT
		TYPE II 14"	TYPE III 14"			
LOG MILE	(FT)	SQ YD	SQ YD	EACH	FOOT	SQ YD
0.26	6	8		20	48	
0.56	6	8		20	48	
0.66	12		16	20	60	16
0.76	6	8		20	48	
0.76	6	8		20	48	
1.20	6	8		20	48	
1.35	6	8		20	48	
1.62	6	8		20	48	
1.89	6	8		20	48	
2.06	6	8		20	48	
2.26	8	11		20	52	
2.26	6	8		20	48	
2.36	10	13		20	56	
2.46	6	8		20	48	
2.56	6	8		20	48	
2.56	6	8		20	48	
2.56	8	11		20	52	
2.76	6	8		20	48	
2.86	6	8		20	48	
2.96	15		20	20	66	20
3.06	6	8		20	48	
3.06	6	8		20	48	
3.46	6	8		20	48	
3.46	10	13		20	56	
3.56	10	13		20	56	
4.06	6	8		20	48	
4.06	8	11		20	52	
4.26	6	8		20	48	
4.36	12		16	20	60	16
5.16	6	8		20	48	
5.46	8	11		20	52	
5.96	6	8		20	48	
6.26	6	8		20	48	
SUBTOTAL	239	267	52	660	1666	52

PATCHING SCHEDULE

SOUTHBOUND LANE						
LOCATION	PATCH LENGTH	CLASS B		DOWEL BARS 1 1/2"	SAW CUTS	WELDED WIRE REINFORCEMENT
		TYPE II 14"	TYPE III 14"			
LOG MILE	(FT)	SQ YD	SQ YD	EACH	FOOT	SQ YD
6.36	10	13		20	56	
6.56	8	11		20	52	
6.76	8	11		20	52	
6.86	6	8		20	48	
7.06	6	8		20	48	
7.36	6	8		20	48	
7.66	6	8		20	48	
8.36	6	8		20	48	
8.56	6	8		20	48	
8.66	6	8		20	48	
8.96	6	8		20	48	
8.96	10	13		20	56	
9.36	6	8		20	48	
10.36	6	8		20	48	
10.48	6	8		20	48	
10.52	12		16	20	60	16
10.63	6	8		20	48	
10.68	6	8		20	48	
10.72	6	8		20	48	
10.83	6	8		20	48	
SUBTOTAL	138	133	16	340	836	16
TOTAL	377	400	68	1000	2502	68

PATCHING SCHEDULE

NORTHBOUND LANE						
LOCATION	PATCH LENGTH	CLASS B		DOWEL BARS 1 1/2"	SAW CUTS	WELDED WIRE REINFORCEMENT
		TYPE II 14"	TYPE III 14"			
LOG MILE	(FT)	SQ YD	SQ YD	EACH	FOOT	SQ YD
0.46	6	8		20	48	
0.46	6	8		20	48	
0.46	13		17	20	62	17
0.46	6	8		20	48	
10.36	6	8		20	48	
9.36	6	8		20	48	
9.26	10	13		20	56	
8.96	6	8		20	48	
8.66	6	8		20	48	
8.36	6	8		20	48	
8.26	12		16	20	60	16
7.66	6	8		20	48	
7.36	6	8		20	48	
7.36	6	8		20	48	
6.86	6	8		20	48	
6.76	10	13		20	56	
6.56	8	11		20	52	
6.36	10	13		20	56	
6.26	6	8		20	48	
5.96	6	8		20	48	
5.46	8	11		20	52	
5.16	8	11		20	52	
4.36	12		16	20	60	16
4.26	6	8		20	48	
4.06	8	11		20	52	
4.06	6	8		20	48	
4.06	6	8		20	48	
3.66	6	8		20	48	
3.56	10	13		20	56	
3.46	10	13		20	56	
3.46	6	8		20	48	
3.06	6	8		20	48	
SUBTOTAL	239	269	49	640	1630	49

PATCHING SCHEDULE

NORTHBOUND LANE						
LOCATION	PATCH LENGTH	CLASS B		DOWEL BARS 1 1/2"	SAW CUTS	WELDED WIRE REINFORCEMENT
		TYPE II 14"	TYPE III 14"			
LOG MILE	(FT)	SQ YD	SQ YD	EACH	FOOT	SQ YD
3.06	6	8		20	48	
2.96	14		19	20	64	19
2.86	6	8		20	48	
2.76	6	8		20	48	
0.46	6	8		20	48	
0.46	6	8		20	48	
2.56	8	11		20	52	
2.56	6	8		20	48	
2.56	6	8		20	48	
2.46	6	8		20	48	
2.46	10	13		20	56	
2.36	10	13		20	56	
2.26	6	8		20	48	
2.16	8	11		20	52	
2.16	6	8		20	48	
2.16	6	8		20	48	
2.06	6	8		20	48	
1.96	6	8		20	48	
1.76	6	8		20	48	
0.76	6	8		20	48	
0.76	6	8		20	48	
0.66	12		16	20	60	16
0.56	8	11		20	52	
0.52	6	8		20	48	
0.26	6	8		20	48	
0.24	6	8		20	48	
0.20	6	8		20	48	
0.20	6	8		20	48	
0.20	6	8		20	48	
0.20	6	8		20	48	
SUBTOTAL	208	243	35	600	1496	35
TOTAL	447	512	84	1240	3126	84

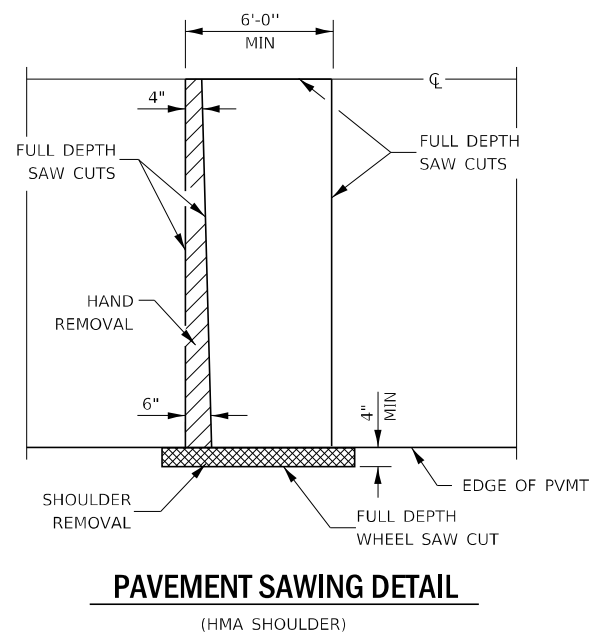

PAVEMENT SAWING DETAIL
(HMA SHOULDER)

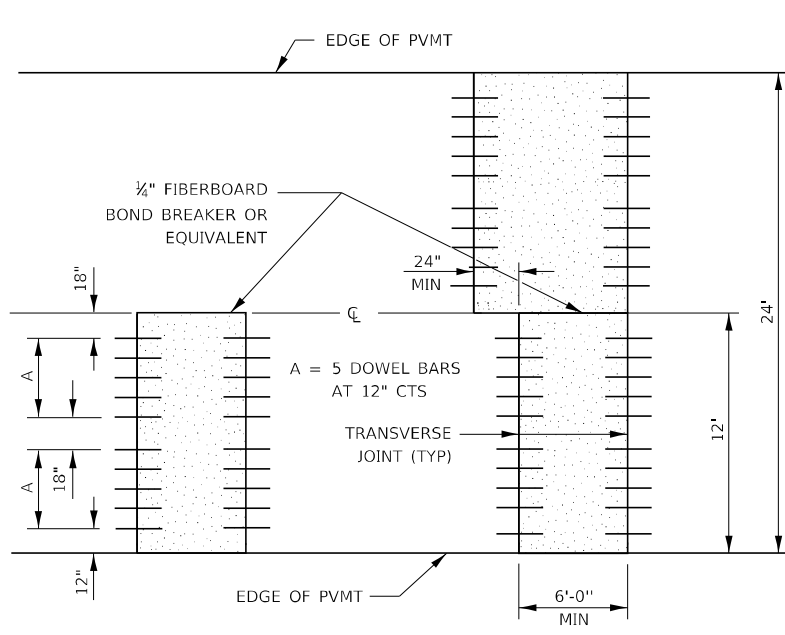

12' WIDE LANES

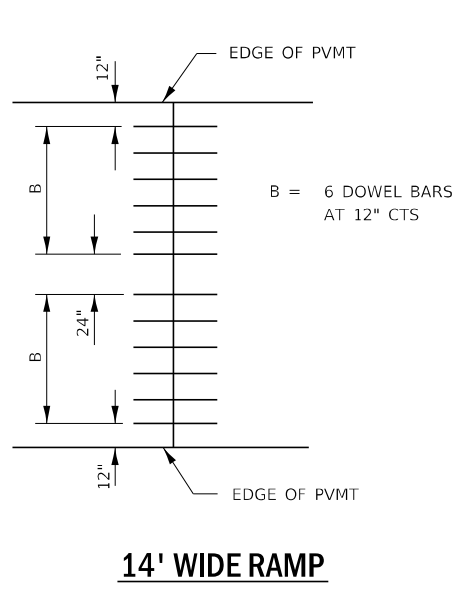

14' WIDE RAMP

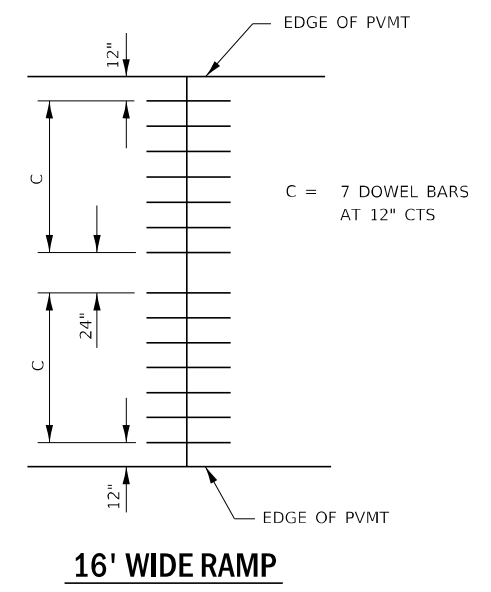

16' WIDE RAMP

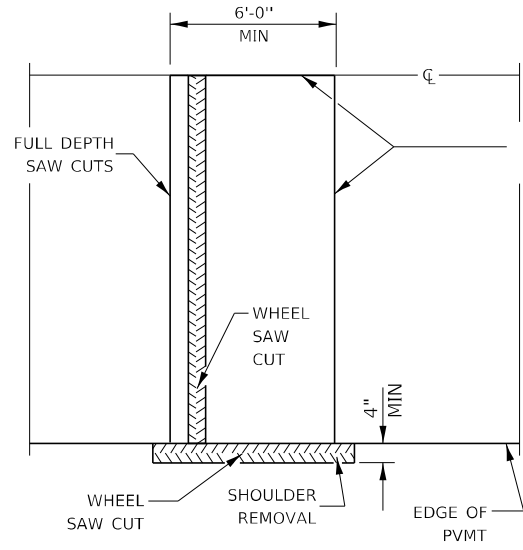

ALTERNATE SAWING DETAIL
(HMA SHOULDER)

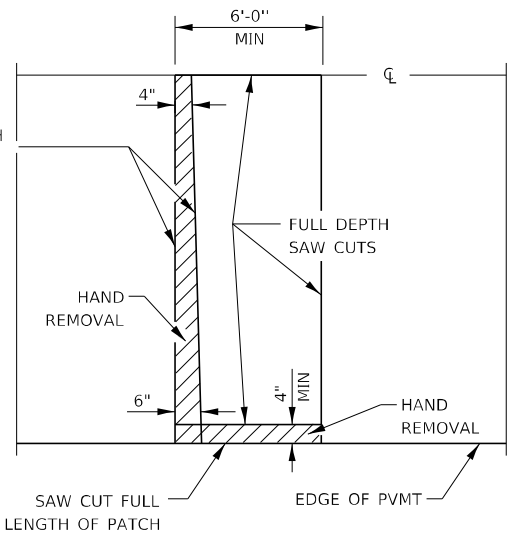

PAVEMENT SAWING DETAIL
(PCC SHOULDER)

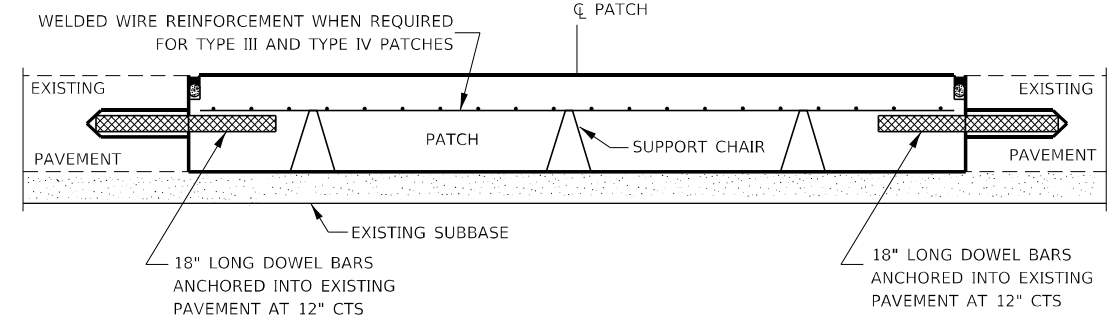

PATCHING WITHOUT HMA OVERLAY

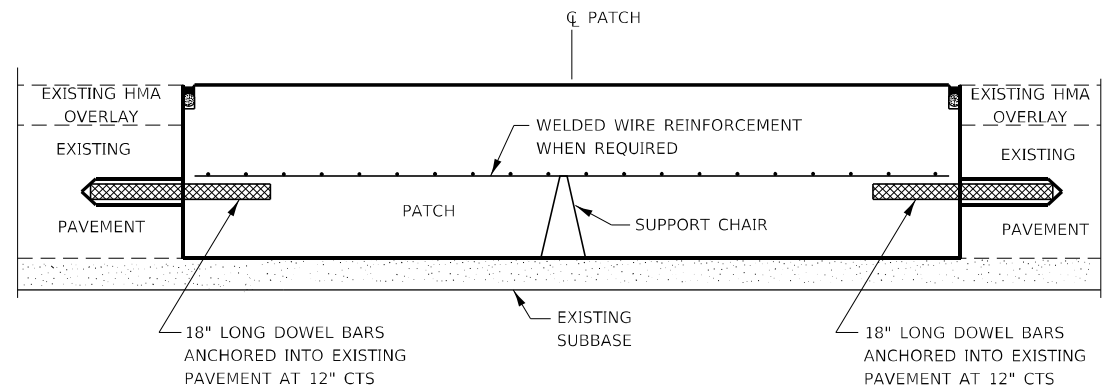

PATCHING WITH HMA OVERLAY

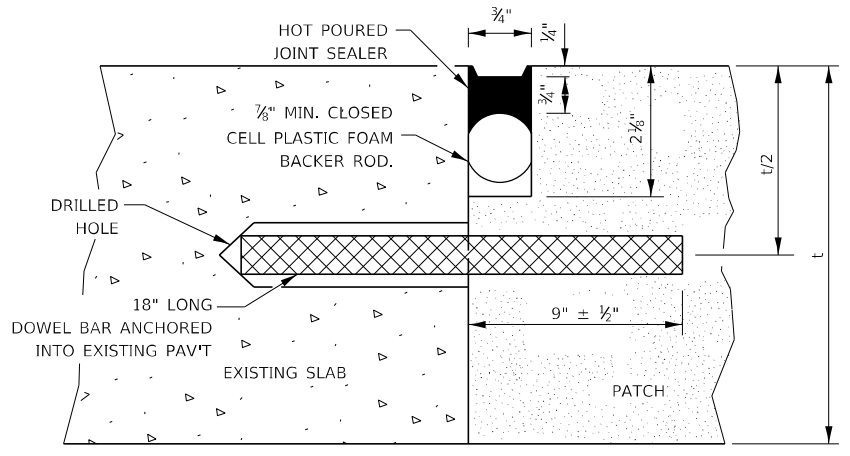

TRANSVERSE JOINT

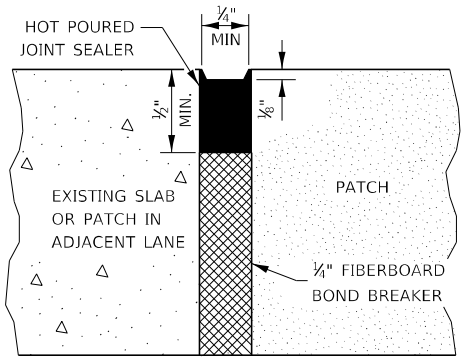

CENTERLINE JOINT

DOWEL BAR TABLE		
PAVEMENT THICKNESS	DOWEL BAR DIAMETER	HOLE DIAMETER
8" OR GREATER	1 1/2"	1 3/8"
7" THRU 7.99"	1 1/4"	1 3/8"
LESS THAN 7"	1"	1 3/8"

GENERAL NOTES

THE TRANSVERSE JOINTS FOR CLASS B PATCHES SHALL ALIGN WITH JOINTS OR CRACKS IN THE ADJACENT LANE WHENEVER POSSIBLE.
SEE STANDARD 420701 FOR DETAILS OF PAVEMENT WELDED WIRE REINFORCEMENT.

MODEL: Default
FILE NAME: p:\subsect-pav-bead\pav\pvd\DOT\Documents\1\DOT Office\Drawings\3\Project\1\366M43\CADD\Drawings\366M43 - PLANS.dgn

USER NAME = woodshank	DESIGNED - EVAN MARINI	REVISED -
PLOT SCALE = 100,0000' / in.	DRAWN - EVAN MARINI	REVISED -
PLOT DATE = 1/25/2022	CHECKED - RON WOODSHANK	REVISED -
	DATE - 1/22/2019	REVISED -

**STATE OF ILLINOIS
DEPARTMENT OF TRANSPORTATION**

CLASS B PATCHING DETAILS

SCALE: SHEET 1 OF 2 SHEETS STA. TO STA.

F.A.S. RTE.	SECTION	COUNTY	TOTAL SHEETS	SHEET NO.
340	(109,110)PP	IROQUOIS	9	7
CONTRACT NO. 66M45				
ILLINOIS FED. AID PROJECT				

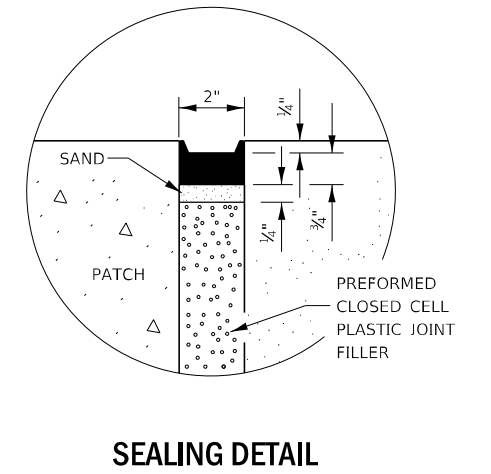
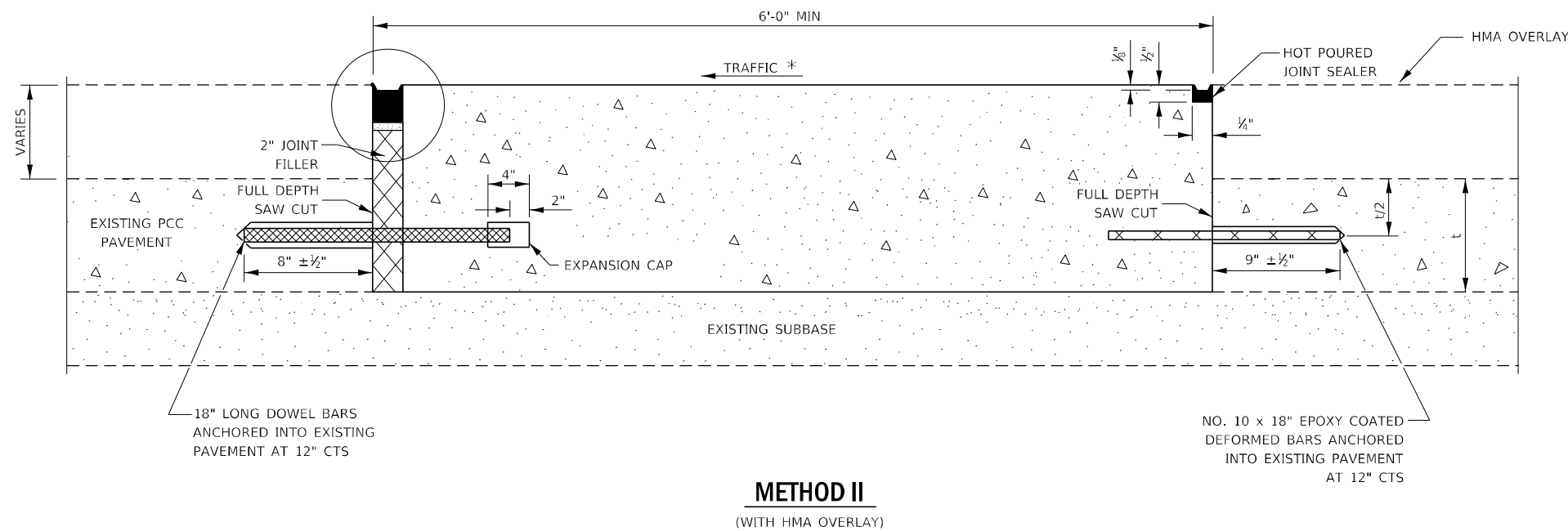
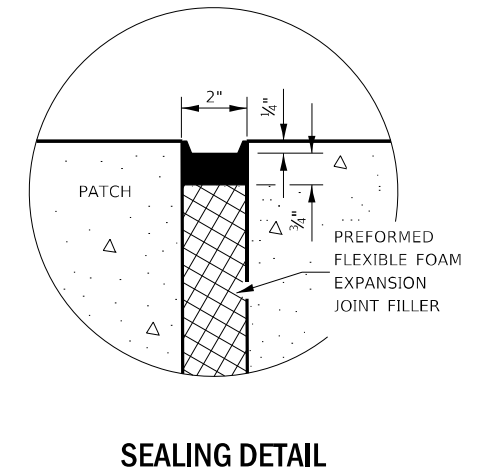
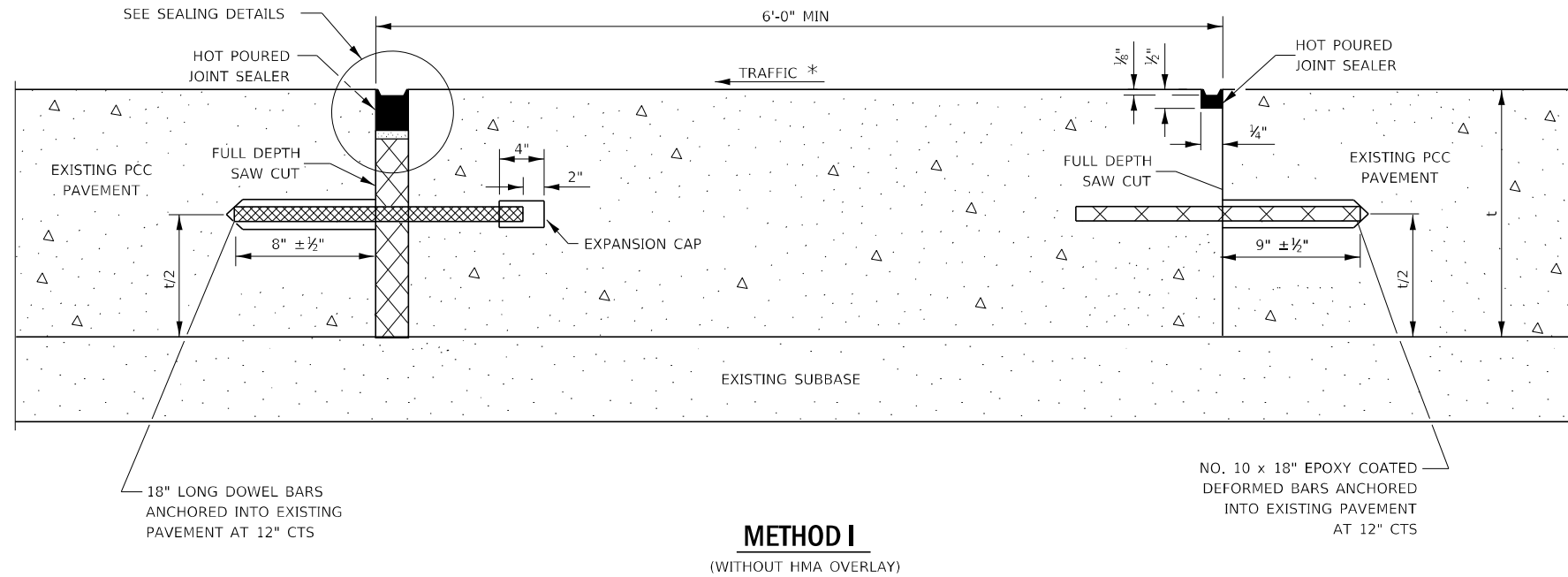

NOTE

* WHEN RE-ESTABLISHING A TRANSVERSE EXPANSION JOINT ON A TWO-WAY ROAD, REVERSE THE ORIENTATION OF THE DOWEL BARS WITH RESPECT TO TRAFFIC FOR ONE OF THE PATCHES SUCH THAT THE JOINT WILL BE CONTINUOUS ACROSS BOTH LANES.

MODEL: Default
FILE NAME: p:\build\paw_bentley.com\PIV\DOT\Documents\DOT Office\Dir\drf_3\Project\10366443\CADD\Drawings\10366443 - PLANS.dgn

USER NAME = woodshank	DESIGNED - EVAN MARINI	REVISED -
PLOT SCALE = 100,0000' / in.	DRAWN - EVAN MARINI	REVISED -
PLOT DATE = 1/25/2022	CHECKED - RON WOODSHANK	REVISED -
	DATE - 1/22/2019	REVISED -

STATE OF ILLINOIS
DEPARTMENT OF TRANSPORTATION

CLASS B PATCHING DETAILS

SCALE: SHEET 2 OF 2 SHEETS STA. TO STA.

F.A.S. RTE.	SECTION	COUNTY	TOTAL SHEETS	SHEET NO.
340	(109,110)PP	IROQUOIS	9	8
CONTRACT NO. 66M45				
ILLINOIS		FED. AID PROJECT		

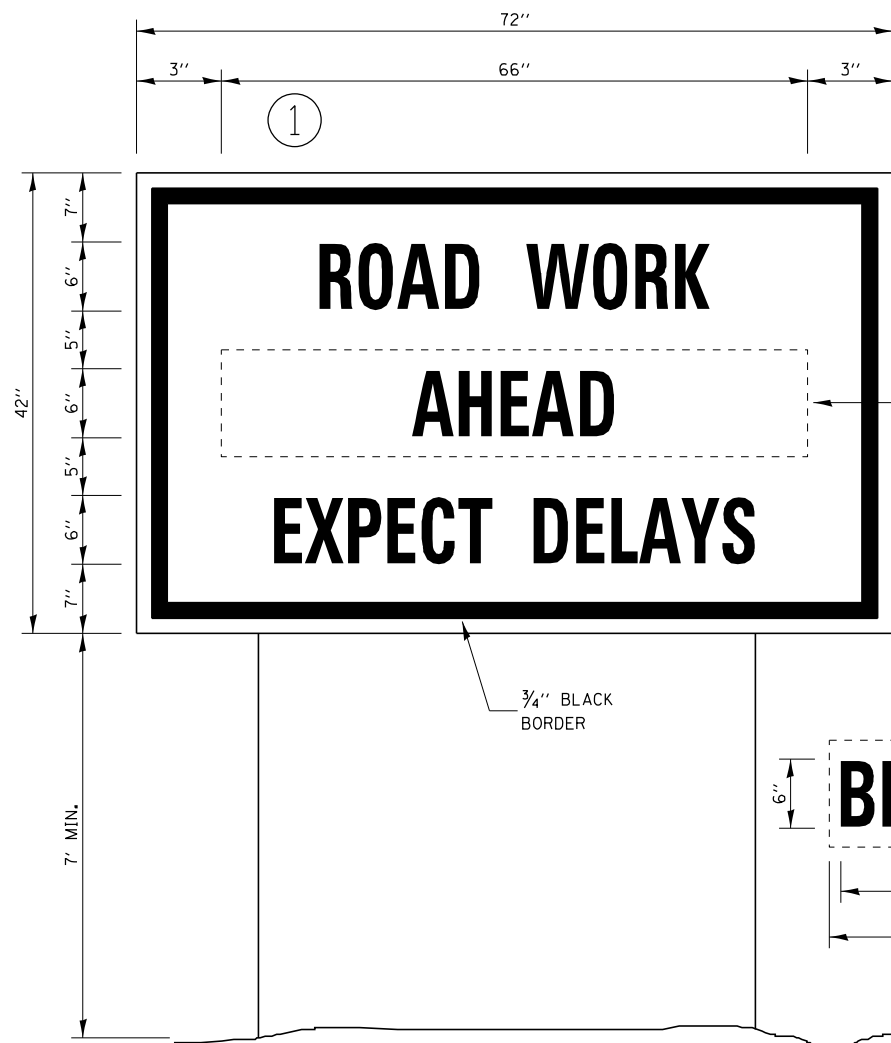

②

USE APPROPRIATE MONTH AND DATE FOR CONTRACT

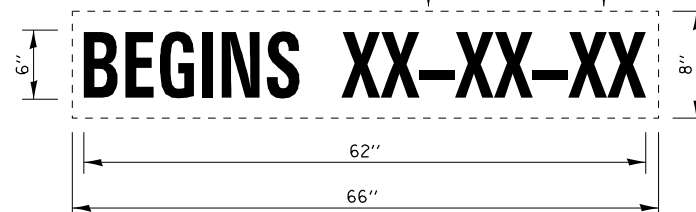

TEMPORARY INFORMATION SIGNING

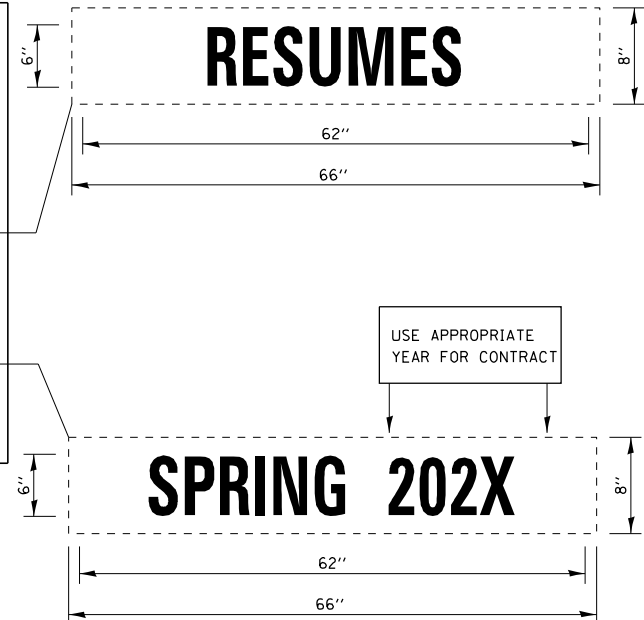
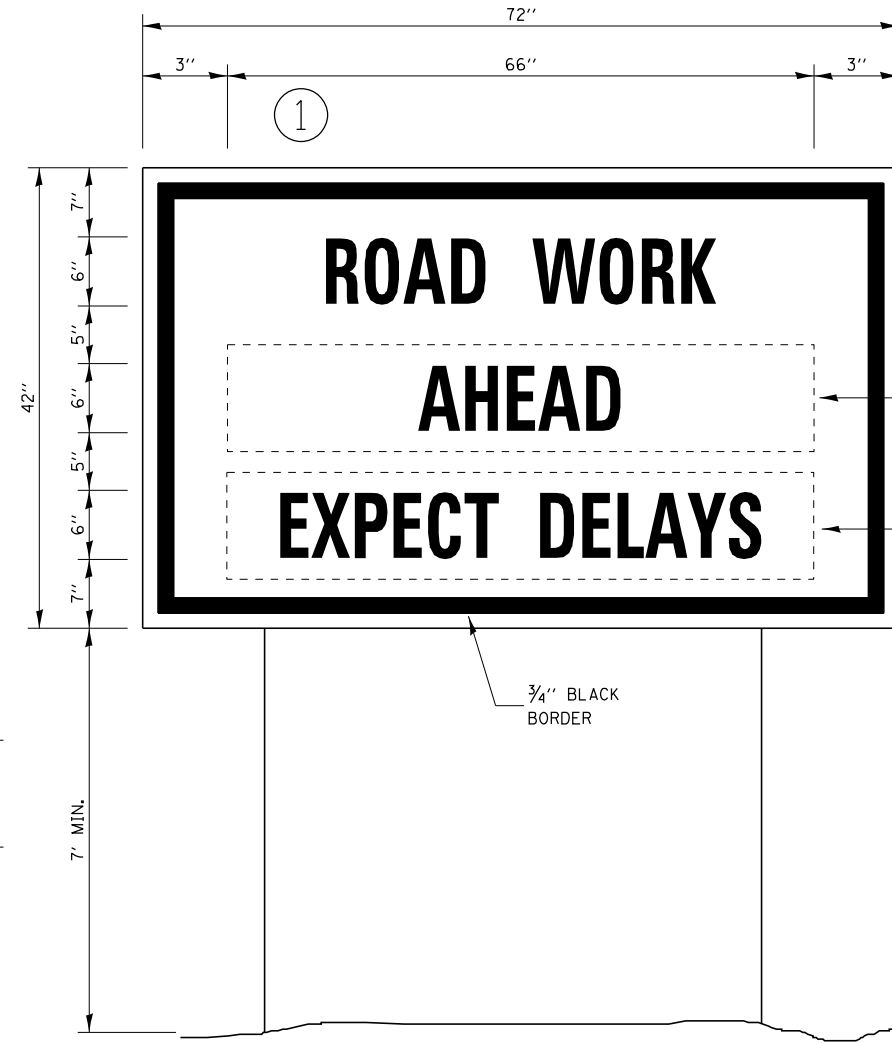

WINTER SHUT DOWN SIGNING

NOTES:

1. USE 6" D BLACK LETTERING ON FLOURESENT ORANGE BACKGROUND.
2. ERECT SIGNS AT LOCATIONS IN ADVANCE OF THE "ROAD CONSTRUCTION AHEAD" SIGNS AS DIRECTED BY THE ENGINEER.
3. ERECT SIGN ① WITH INSTALLED PANEL ② A MINIMUM OF ONE WEEK PRIOR TO THE START OF THE LANE CLOSURE.
4. REMOVE PANEL ② ON THAT DATE.
5. SEE SPECIAL PROVISION "TEMPORARY INFORMATION SIGNING" FOR ADDITIONAL INFORMATION.
6. WILL BE PAID FOR PER SQ FT AS "TEMPORARY INFORMATION SIGNING". EACH SIGN = 21 SQ FT AND THE DATE PANEL ② WILL NOT BE MEASURED SEPARATELY FOR PAYMENT.

FILE NAME =	USER NAME = woodshank1	DESIGNED - EVAN MARINI	REVISED -	STATE OF ILLINOIS DEPARTMENT OF TRANSPORTATION	TEMPORARY INFORMATION SIGNING			F.A.S RTE.	SECTION	COUNTY	TOTAL SHEETS	SHEET NO.
pw:\illdot\pw\berntley.com\PWIDOT\Documents\IDOT Office\es\District 3\Projects\3\366M43\CADData\366M43 - PLANS.dwg	DRAWN - EVAN MARINI	REVISIED -	340					(109,110)PP	IROQUOIS	9	9	
Default	PLOT SCALE = 100,0000' / in.	CHECKED - RON WOODSHANK	REVISED -		CONTRACT NO. 66M45			ILLINOIS FED. AID PROJECT				
	PLOT DATE = 1/25/2022	DATE - 1/22/2019	REVISED -		SCALE:	SHEET 1	OF 1	SHEETS	STA.	TO STA.		