

620-PAVEMENT MARKING-WATERBORNE NOTES

THE PAVEMENT MARKING-WATERBORNE (620) SHALL BE PLACED IN ACCORDANCE WITH ITEM 620 "PAVEMENT MARKING" AS STATED ON PAGE 77 OF THE SUPPLEMENTAL SPECIFICATIONS AND RECURRING SPECIAL PROVISIONS, ADOPTED JULY 1, 2004.

THIS ITEM SHALL CONSIST OF RUNWAY AND HOLDING LINE MARKING IN ACCORDANCE WITH THESE SPECIFICATIONS AND AT THE LOCATIONS SHOWN ON THE CONSTRUCTION PLANS. ALL RUNWAY MARKING WILL BE WHITE IN COLOR AND THE HOLDING LINE MARKING WILL BE YELLOW IN COLOR WITH A BLACK OUTLINE. THE PROPOSED PAVEMENT MARKING WILL BE APPLIED IN TWO APPLICATIONS.

ANY MATERIAL DELIVERED THAT FAILS TO MEET THE SPECIFICATIONS SHALL BE DISPOSED OF BY THE VENDOR AND IMMEDIATELY REPLACED WITH ACCEPTABLE MATERIAL ENTIRELY AT THE VENDOR'S EXPENSE, INCLUDING HANDLING AND TRANSPORTATION CHARGES.

ALL PROPOSED MARKING WILL BE COMPLETED IN ACCORDANCE WITH THE DETAILS SHOWN ON THE CONSTRUCTION PLANS.

GLASS BEADS SHALL BE REQUIRED ONLY ON THE SECOND APPLICATION.

CUT-OFF SHEETS WILL BE REQUIRED TO INSURE STRAIGHT EDGES.

THE PROPOSED MARKING WILL BE PAID FOR UNDER ITEM:
AR620520 PAVEMENT MARKING-WATERBORNE 24,000 S.F.

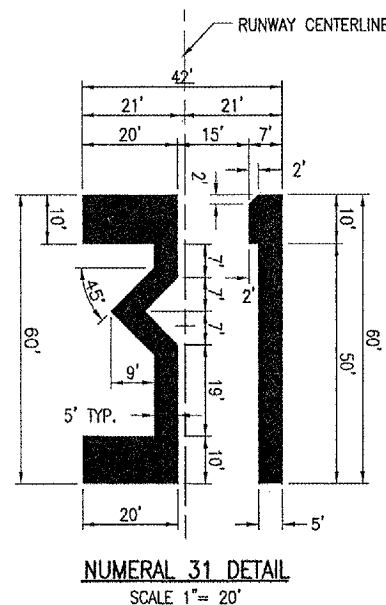
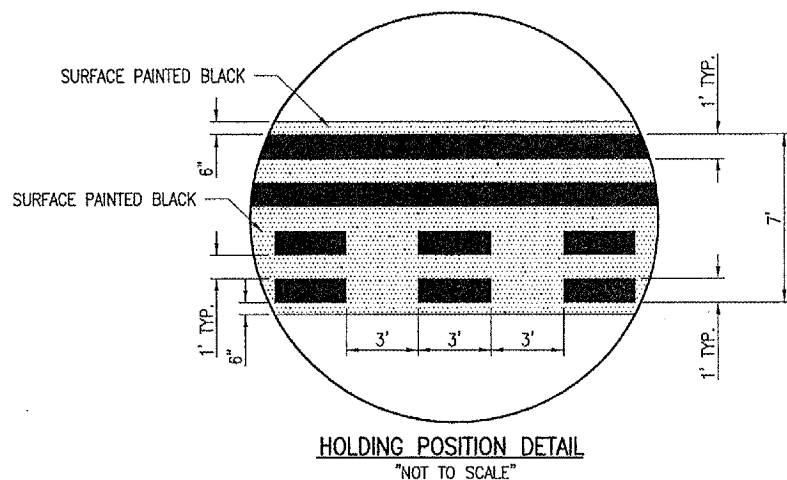
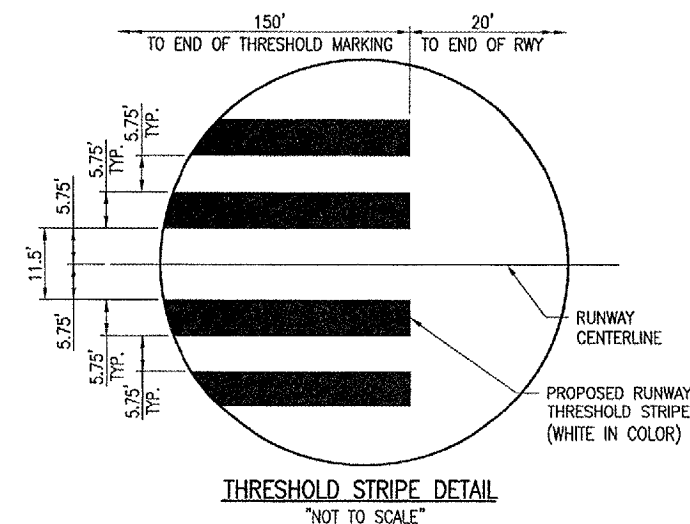
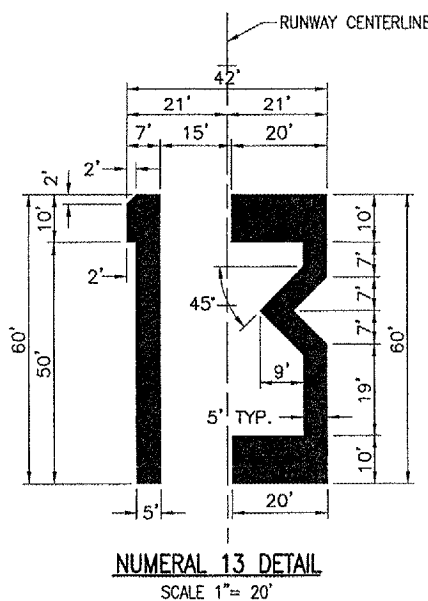
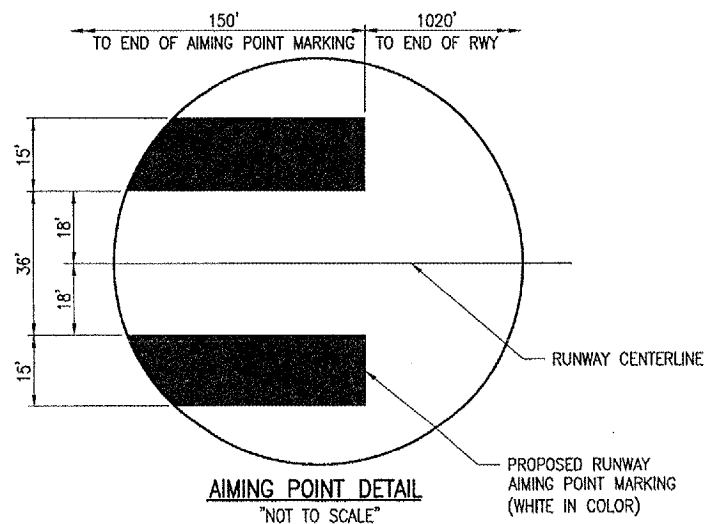

MARKING QUANTITIES			
DESCRIPTION	UNIT AREA	NO. REQUIRED	TOTAL AREA
RUNWAY 13-31 CENTERLINE STRIPE	360	18	6,480
THRESHOLD STRIPE (RUNWAY END 13)	862.5	6	5,175
AIMING POINT	2,250	4	9,000
NUMERAL 1 (OF NUMERAL 13 AND 31)	320	2	640
NUMERAL 3 (OF NUMERAL 13 AND 31)	700	2	1,400
TOTAL WHITE			22,695
HOLDING POSITION (RUNWAY END 31)	210	1	210
TAXIWAY CENTERLINE	745	1	745
TOTAL YELLOW			955
HOLDING POSITION (BLACK BORDER)	350	1	350
TOTAL BLACK			350
TOTAL MARKING			24,000

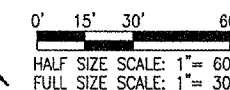
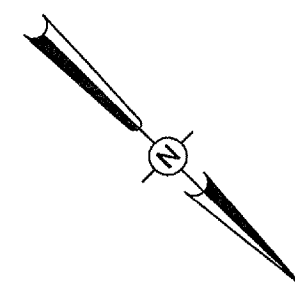
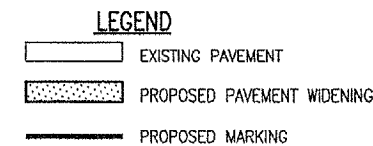

MAR 29, 2006 10:51 AM CAH I:\AIRPORTS\SAVANNA\826-06RWY\AIRPORT\SHEETS\R-151MRK.DWG - STA. 221+50 TO STA. 229+47.00

DATE	REVISION	BY

TRI-TOWNSHIP AIRPORT
SAVANNA, CARROLL COUNTY
ILLINOIS

A.I.P. PROJ.: 3-17-0091-812
IL PROJ.: SFT-3538

FILE PROJECT No. 826-06RWYD_08DD	DATE 11/02/05
PLANNED R-151MRK.DWG	B.A.K. 11/02/05
SCALE 1" = 30'	B.A.K. 11/02/05
DATE 11/02/05	C.A.H. 01/12/06
LAYOUT	
DRAWN	
REVIEWED	

Hanson Professional Services, Inc.
1526 South Sixth Street
Springfield, Illinois 62702-2886
Offices Nationwide

PROPOSED WIDENING
OF RUNWAY 13/31

PROPOSED
MARKING PLAN

STA. 221+50 TO STA. 229+47.00