

STATE OF ILLINOIS
DEPARTMENT OF TRANSPORTATION

ROUTE NO.	SECTION	COUNTY	SHEET NO.	SHEET NO.
595	1-1	ROCK ISLAND	239	126
FED. H&C DIST. NO. 2		ILLINOIS	FED. H&C PROJECT	
Contract No. 84986				

SHEET NO. 12
18 SHEETS

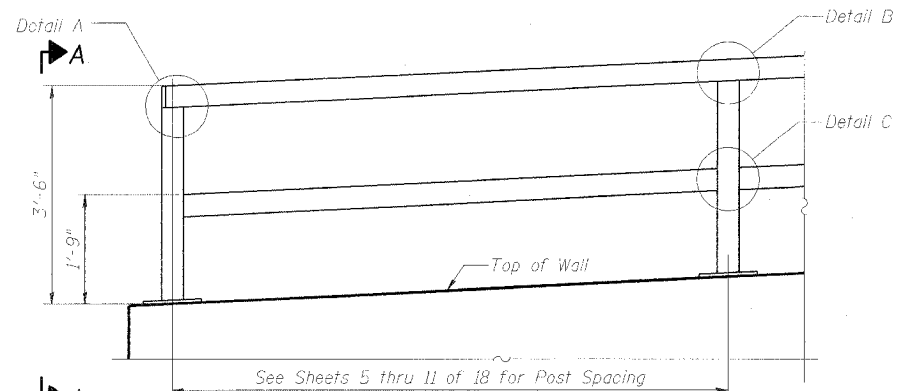

ELEVATION AT WEST END
(Looking North)

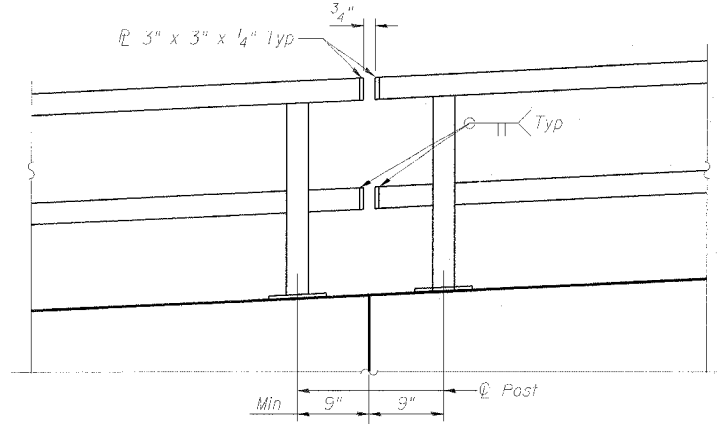

ELEVATION AT CONSTRUCTION JOINT

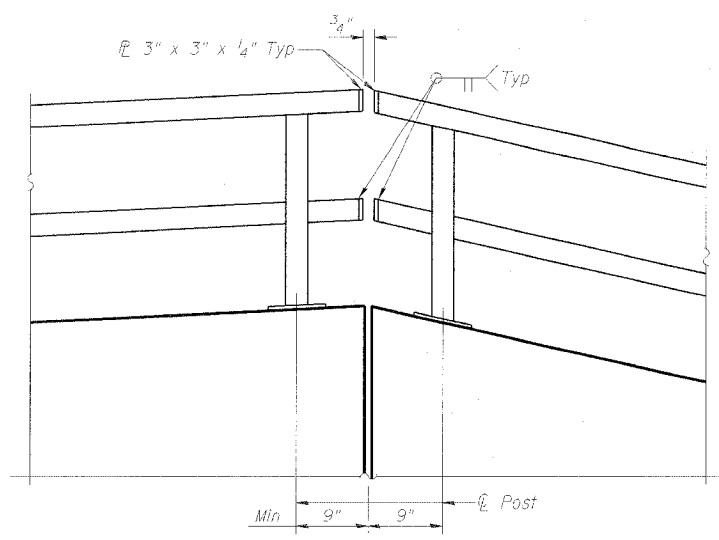

ELEVATION AT EXPANSION JOINT

DESIGNED	-	NDR
CHECKED	-	DSE
DRAWN	-	RTT
CHECKED	-	DSE
DATE	-	JAN 31, 2006

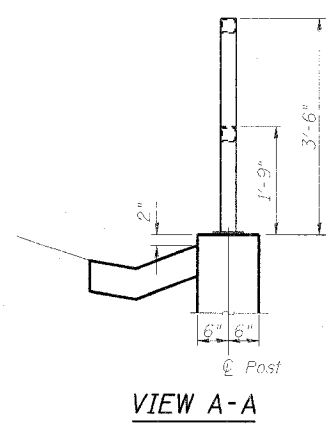

VIEW A-A

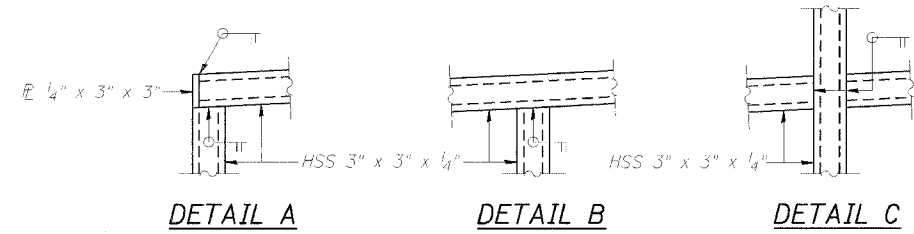

DETAIL A

DETAIL B

DETAIL C

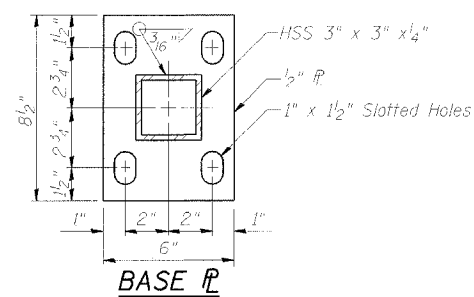

BASE PL

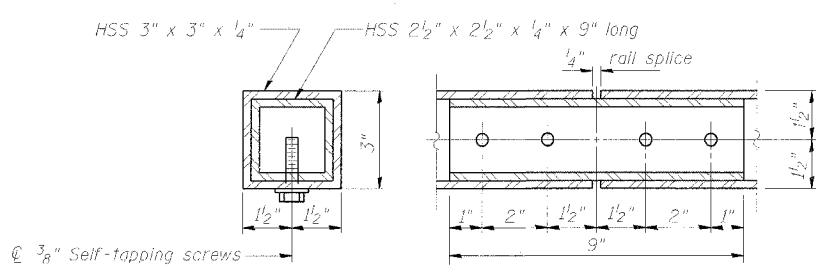

RAIL SPLICE

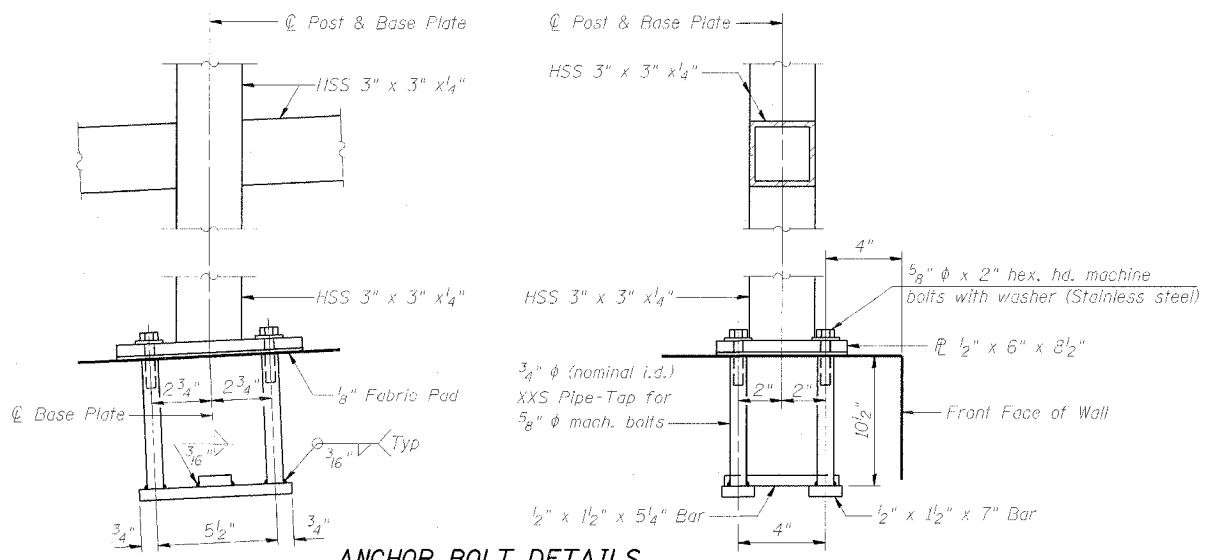

ANCHOR BOLT DETAILS

(In lieu of the cast-in-place anchor device shown, the Contractor has the option of drilling and epoxy grouting 5/8" φ anchor rods. Embedment shall be according to the manufacturer's specifications.)

NOTES

Railing shall be according to Section 509 of the Standard Specifications, except as noted, and will be paid for at the Contract Unit Price per meter for Pedestrian Railing.
Hollow structural steel tubing shall conform to the requirements of ASTM designation A 500, Grade B, structural steel tubing.
All other steel shapes and plates shall conform to the requirements of AASHTO M 270M Grade 250.
If the option of drilling and epoxy grouting the anchor rods is chosen, the Contractor shall use the capsule or the adhesive cartridge type anchor rods that have been previously tested and given a prior approval by the Department. The Contractor shall install these anchor rods in pre-drilled holes according to the manufacturer's recommendations and procedures. The capsule or the adhesive cartridge shall be sealed with premeasured amounts of the adhesive chemical.
Space reinforcement to miss anchor rods.
All posts, railing, splices, anchor devices, and bent plates shall be galvanized after shop fabrication according to AASHTO M 111 and ASTM A 385. All bolts, nuts, washers and anchor rods shall be galvanized according to AASHTO M 232 except stainless steel bolts as noted.
Vent holes for galvanizing shall be placed in the posts and rails at locations that will not allow the accumulation of moisture in the members.

BILL OF MATERIAL

Item	Unit	Quantity
Pedestrian Railing	Foot	515.8

Illinois Firm Registration No. 184-00533

Stanley Consultants INC.
850 West Higgins Road, Suite 730, Chicago, Illinois 60631-2808
www.stanleygroup.com

**PEDESTRIAN RAILING
RETAINING WALL D ALONG
IL ROUTE 5
FA 595 (IL ROUTE 5) SECTION 1-1
ROCK ISLAND COUNTY
STA 76+50.00 TO STA 81+70.00
STRUCTURE NO. 081-W006**