

CIRCUIT 1
ALL CONDUCTOR IS #6

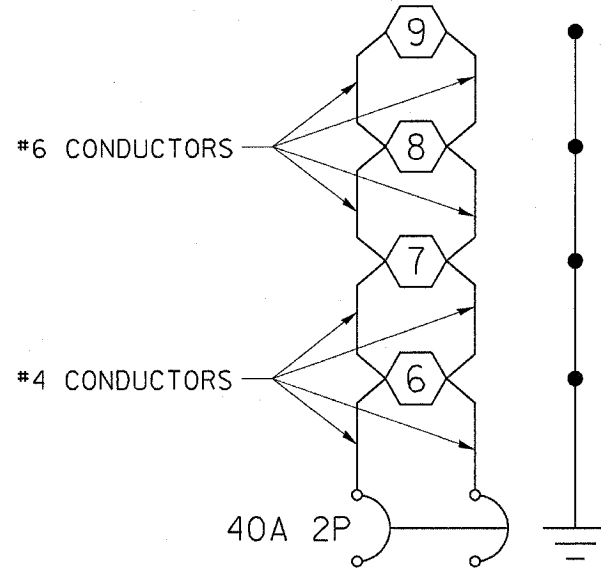

CIRCUIT 2

LIGHT POLE IDENTIFICATION

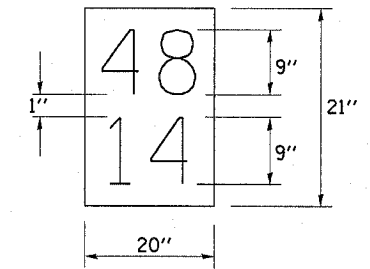

THE CONTRACTOR SHALL FURNISH AND INSTALL A LIGHT POLE IDENTIFICATION ON EACH NEW LIGHT POLE, AS SHOWN ABOVE, INCIDENTAL TO THE RESPECTIVE LIGHT POLE PAY ITEM.

THE LIGHT POLE IDENTIFICATION SHALL BE AS SPECIFIED IN ARTICLE 1069.02 OF THE STANDARD SPECIFICATIONS FOR ROAD AND BRIDGE CONSTRUCTION. APPROXIMATELY 7' ABOVE THE ADJACENT PAVEMENT GRADE, VISIBLE TO APPROACHING TRAFFIC, IN ACCORDANCE WITH HIGHWAY STANDARD 720001.

I-80 & RIDGE ROAD LOCATION NUMBER 48, POLE NUMBER 1-15.

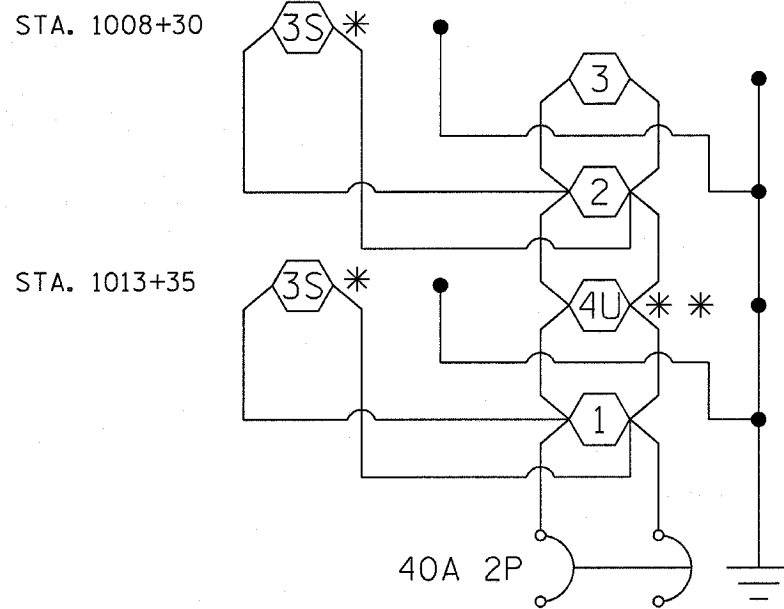

CIRCUIT 3
ALL CONDUCTOR IS #6

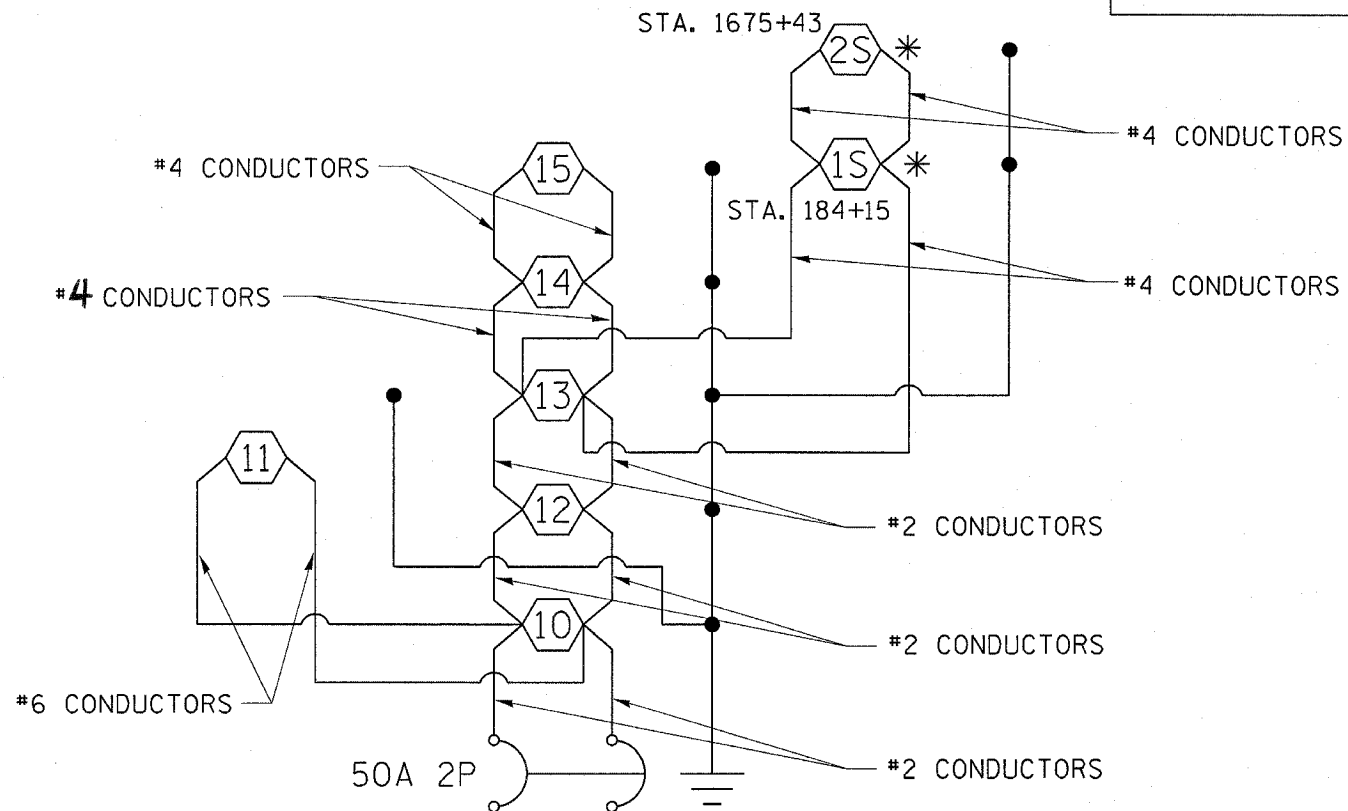

CIRCUIT 4

LEGEND

- * SIGN LIGHTING
- ** UNDERPASS LIGHTING

REVISIONS	
NAME	DATE
MJ	4-11-06

ILLINOIS DEPARTMENT OF TRANSPORTATION

**PROPOSED LIGHTING
CIRCUIT DIAGRAMS**

SCALE: VERT.
HORIZ.

DRAWN BY
CHECKED BY

ADDED SHEET 4-11-06 MJ

PER ADDENDUM