

Benchmark: Stainless Steel rod in sleeve with cast cap and lid, GPS monument No. 536, 0.1 mile west of the Cook County line on US Rte. 6. Sta. 477+61, 32' Lt., Elev. 668.19

Existing Structure: Structure No. 016-1402 located just north of the intersection of U.S. Route 6 and 179th Street and south of U.S. Route 6 and Brookhill Drive in the Village of Orland Park, Cook County was built before 1944. Existing culvert is a cast-in-place reinforced concrete single cell box culvert 10' X 2.5'. Skew of the culvert is approximately 40°. The length of the culvert is approximately 65'. Stage construction will be utilized to maintain traffic during construction.

No Salvage.

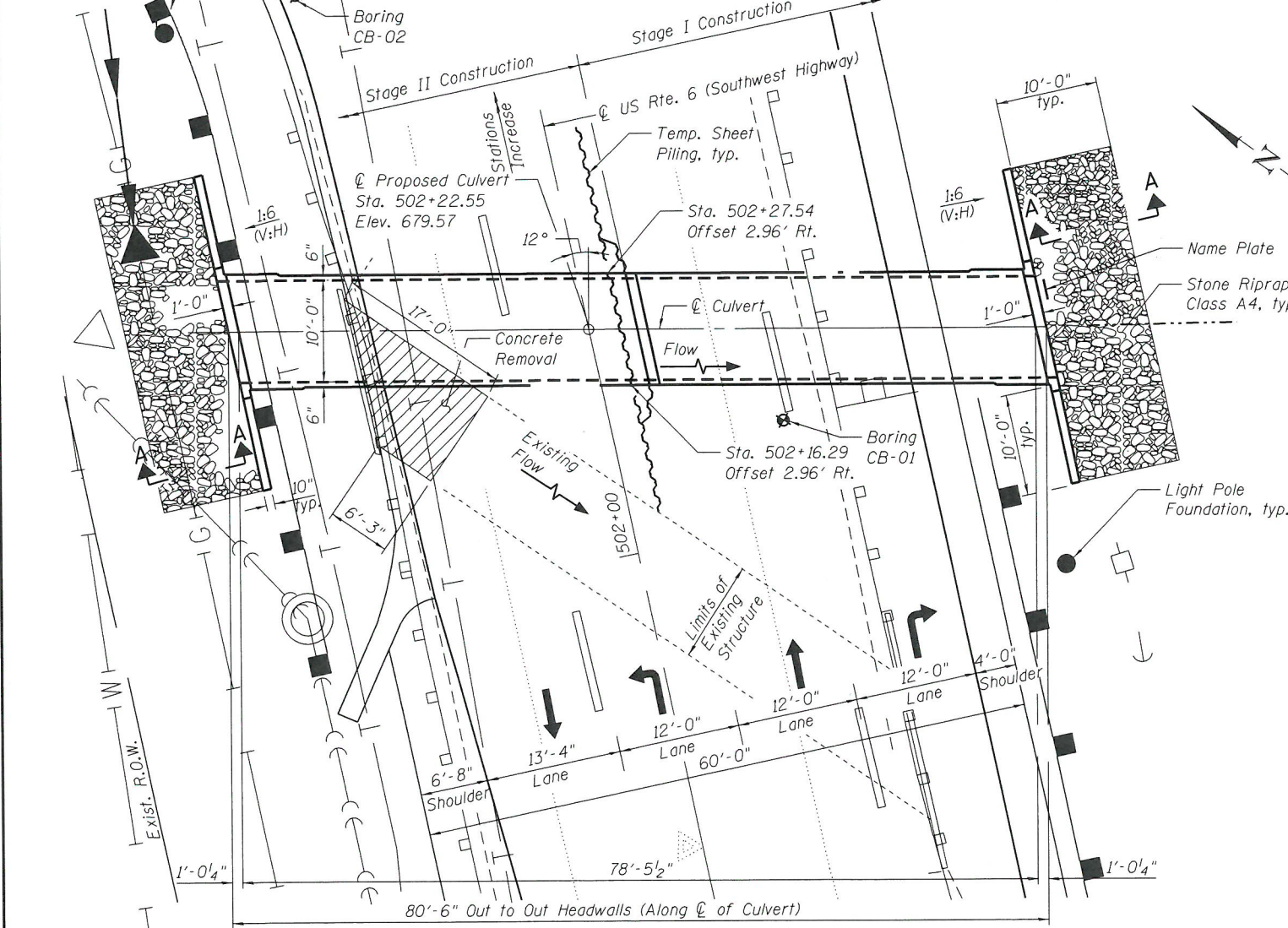
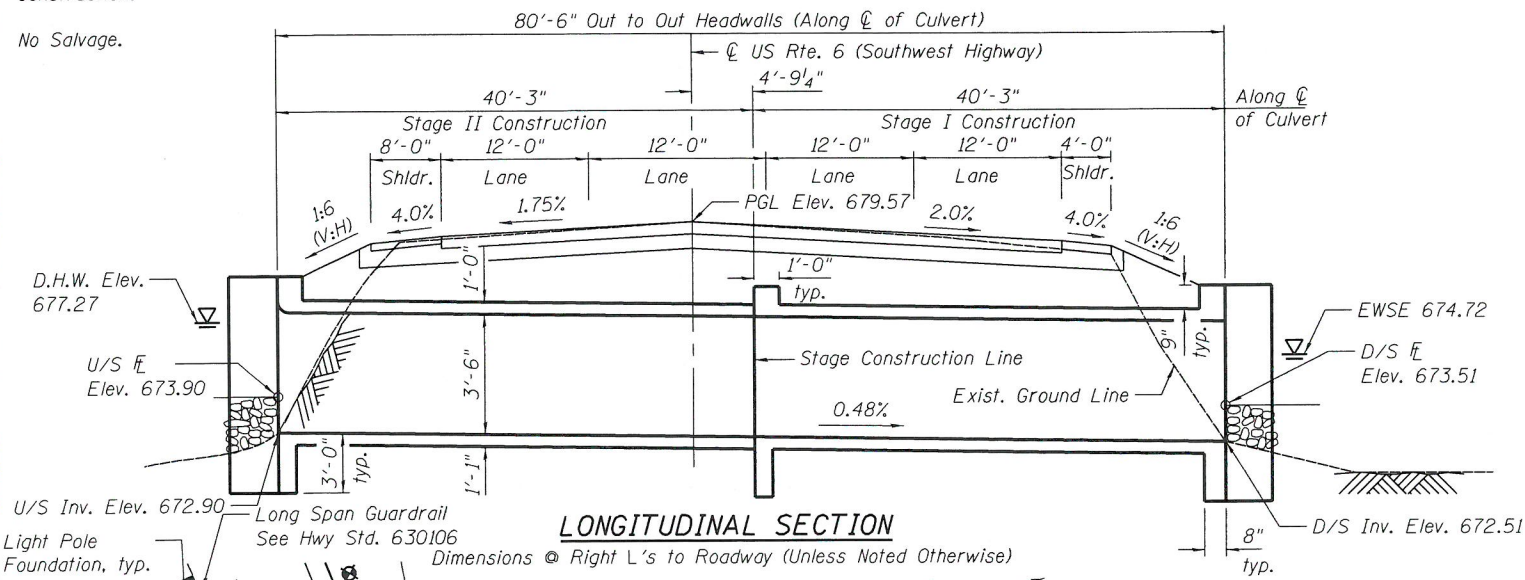

PLAN
80'-6" Out to Out Headwalls (Along \bar{C} of Culvert)

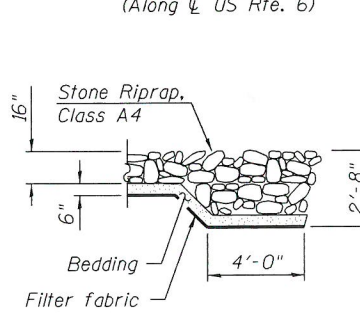
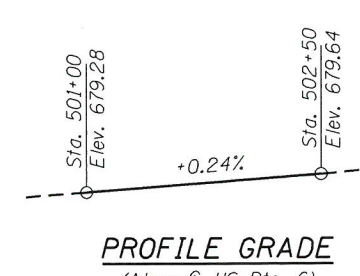

SECTION A-A

STATION 502+22.55
BUILT 20 BY
STATE OF ILLINOIS
LOADING HL-93
STRUCTURE NO. 016-2282

NAME PLATE
See Std. 515001

WATERWAY INFORMATION

Flood	Freq. Yr.	Q C.F.S.	Opening Sq. Ft.		Head - Ft.		Headwater El.		
			Exist.	Prop.	Exist.	Prop.	Exist.	Prop.	
	2	30.7	11.1	12.3	675.13	0.07	0	675.15	675.13
	10	72.3	16.9	18.1	675.71	0.35	0.17	676.01	675.88
Design	50	149.1	23.8	25.0	676.40	0.99	0.87	677.34	677.27
Base	100	194.2	25.0	25.0	676.71	1.68	1.56	678.34	678.27
Overtopping (E)	50<100								
Overtopping (P)	50<100								
Max. Calc.	500	272.8	25.0	25.0	677.15	2.76	2.70	679.86	679.85



DATE SIGNED: 1/30/2018
EXP. DATE: 1/30/2024

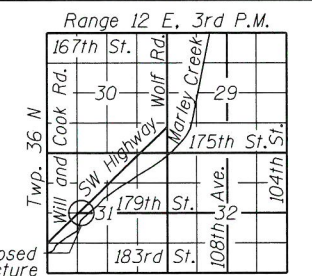

LOCATION SKETCH

GENERAL NOTES

- Areas of excavation required for removal of the existing structure or construction of the new culvert shall be backfilled with Porous Granular Embankment up to the top of top slab elevation in accordance with Section 502 of the Standard Specifications. The cost shall be included in the cost for Concrete Box Culverts.
- All excavation required for construction of the culvert as shown in these plans and in accordance with the Standard Specifications shall be included in the cost for Concrete Box Culverts.
- Reinforcement bars designated (E) shall be epoxy coated.
- The Contractor is advised that the existing box culvert is in a deteriorated condition with reduced load carrying capacity. It is the Contractor's responsibility to account for the condition of the culvert when developing construction procedures for the removal and replacement of the culvert.
- The Contractor shall be responsible to divert the stream flow during construction to keep construction area free of water. The method of water diversion shall be subject to the approval of the Engineer and the cost shall be included in the cost for Concrete Box Culverts.
- Layout of the slope protection system may be varied to suit ground conditions in the field as directed by the Engineer.
- If the Contractor chooses to alter the temporary cantilevered sheet piling design requirements shown on the plans, a design submittal including plan details and calculations will be required for review and acceptance by the Engineer.

SCOPE OF WORK

- Install temporary sheet piling at location shown on the plans and as directed by the Engineer.
- Remove existing roadway and embankment for Stage I Construction. Also remove existing wingwall and headwall at the downstream end of the existing culvert.
- Construct proposed culvert and roadway in Stage I Construction. Construct wingwalls at downstream end.
- Remove existing roadway and embankment for Stage II Construction. Remove $\pm 11'-8"$ (Dim. taken along \bar{C} of structure) of the existing culvert conflicting with the proposed culvert at the upstream end.
- Construct proposed culvert and roadway in Stage II Construction. Construct wingwalls at upstream end.
- Drill cores on top of pavement and fill remaining existing culvert and pipes with Controlled Low-Strength Material after the flow has been diverted to proposed culvert.
- Construct Leveling binder and surface course during Roadway Stage III Construction.

DESIGN SPECIFICATIONS

2014 AASHTO LRFD Bridge Design Specifications, 6th Edition with 2016 interim revisions

DESIGN STRESSES

FIELD UNITS
f'c = 3,500 psi
fy = 60,000 psi (Reinforcement)

PRECAST UNITS
f'c = 5000 psi (Min.)
fy = 60,000 psi (Reinforcement)
fy = 65,000 psi (Welded Wire Fabric)

LOADING HL-93

Allow 50#/sq. ft. for future wearing surface.

GENERAL PLAN & ELEVATION

F.A.U. 0297 US ROUTE 6
OVER UNNAMED DITCH
SECTION 3178G-N(14)
COOK COUNTY
STATION 502+22.55
STRUCTURE NO. 016-2282



USER NAME = jent	DESIGNED - AB	REVISD
PLOT SCALE = 16,0000' / in.	CHECKED - JMT	REVISD
PLOT DATE = 1/30/2018	DRAWN - JN	REVISD
	CHECKED - JMT	REVISD

STATE OF ILLINOIS
DEPARTMENT OF TRANSPORTATION

F.A.U. RTE.	SECTION	COUNTY	TOTAL SHEETS	SHEET NO.
0297	3178G-N(14)	COOK	151	102
CONTRACT NO. 60Y26				
ILLINOIS FED. AID PROJECT				

INDEX OF SHEETS

1. General Plan & Elevation
2. Index of Sheets, Total Bill of Material & Construction Staging
3. Temporary Concrete Barrier
4. Culvert Details
5. Bar Splicer Assembly and Mechanical Splicer Details
6. Boring Logs

TOTAL BILL OF MATERIAL

ITEM	UNIT	TOTAL
Porous Granular Embankment	Cu Yd	173
Stone Riprap, Class A4	Sq Yd	72
Filter Fabric	Sq Yd	72
Concrete Removal	Cu Yd	15.2
Reinforcement Bars, Epoxy Coated	Pound	22,180
Bar Splicers	Each	58
Name Plates	Each	1
Temporary Sheet Piling	Sq Ft	810
Concrete Box Culverts	Cu Yd	92.5
Controlled Low Strength Material, Special	Cu Yd	49.5
Membrane Waterproofing for Buried Structures	Sq Ft	126

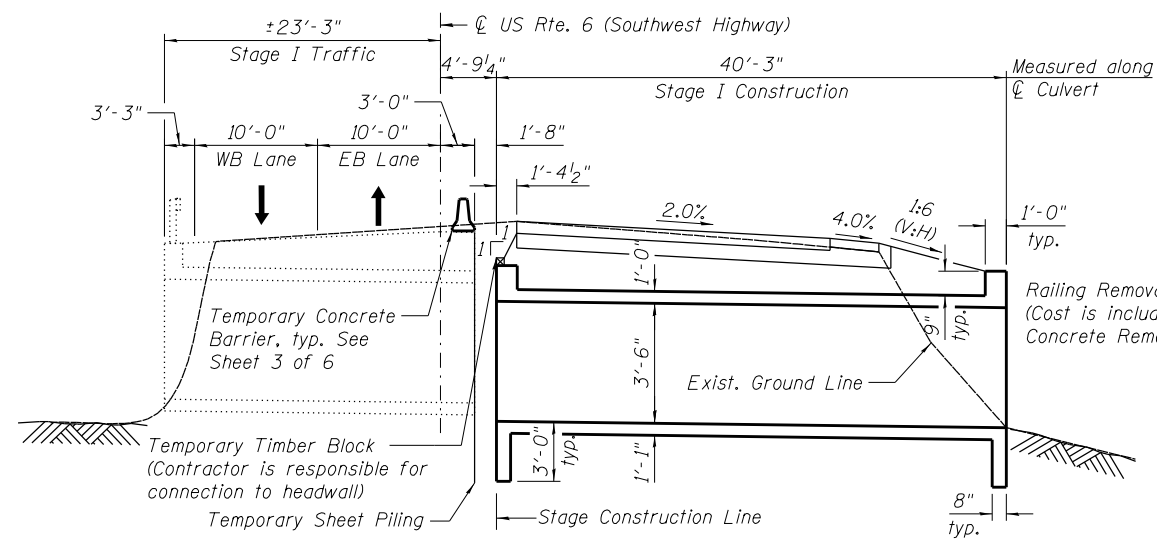

STAGE I CONSTRUCTION

Dimensions @ Right L's to Roadway (Unless Noted Otherwise) (Looking East)

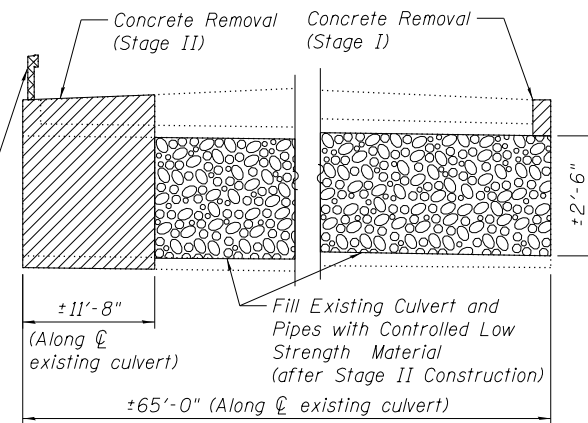

EXISTING STRUCTURE DETAILS

(Looking East)

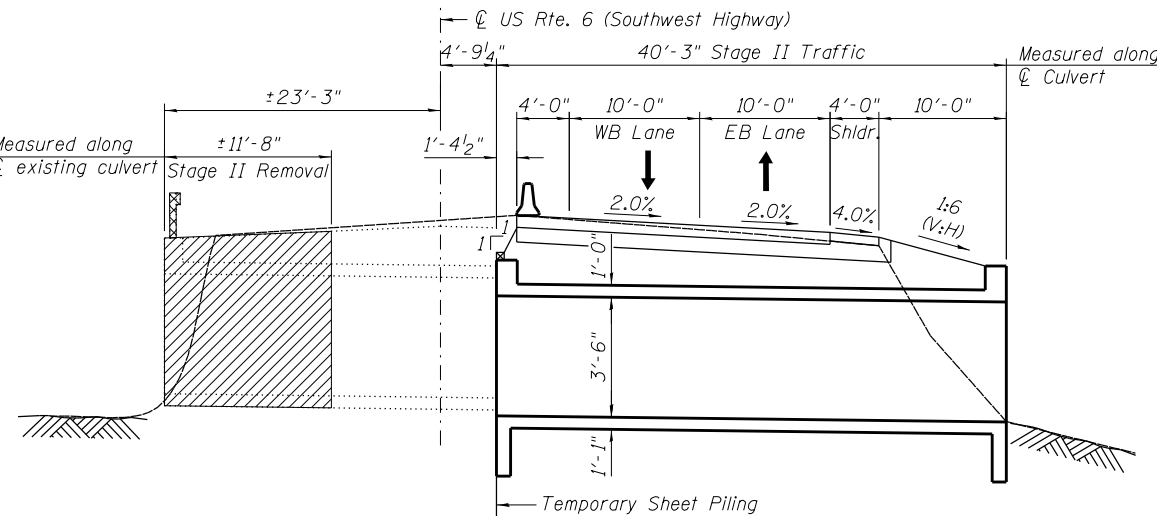

STAGE II REMOVAL

Dimensions @ Right L's to Roadway (Unless Noted Otherwise) (Looking East)

Note:
For quantity of Temp. Conc. Barrier, See roadway plans.

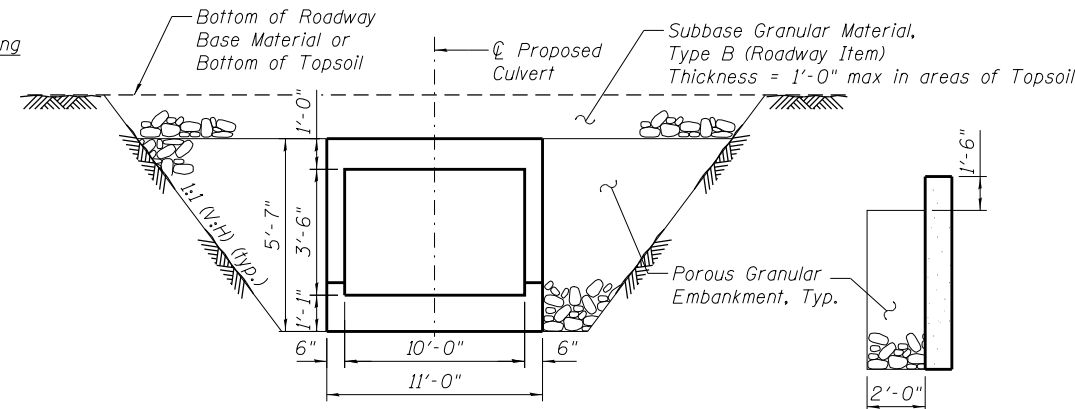

SECTION THRU BARREL

(At Right L's to centerline of Culvert)

SECTION THRU WINGWALL

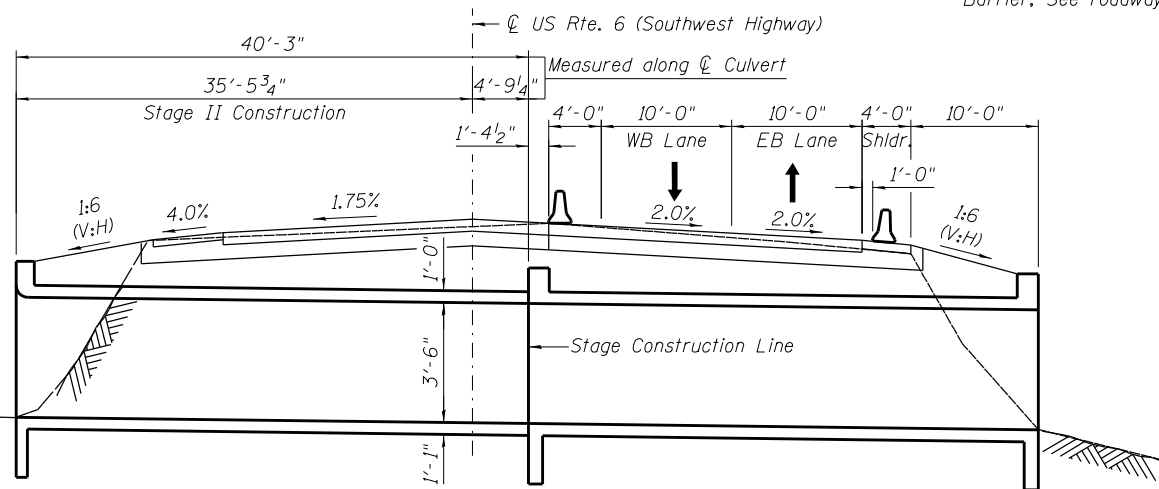

STAGE II CONSTRUCTION

Dimensions @ Right L's to Roadway (Unless Noted Otherwise) (Looking East)

LEGEND

- Concrete Removal
- Railing Removal (Cost included with Concrete Removal)

NOTE:

Excavation for construction of the box culvert and the wingwalls, including the excavation necessary to construct the Porous Granular Embankment, is included with the cost of Concrete Box Culverts.

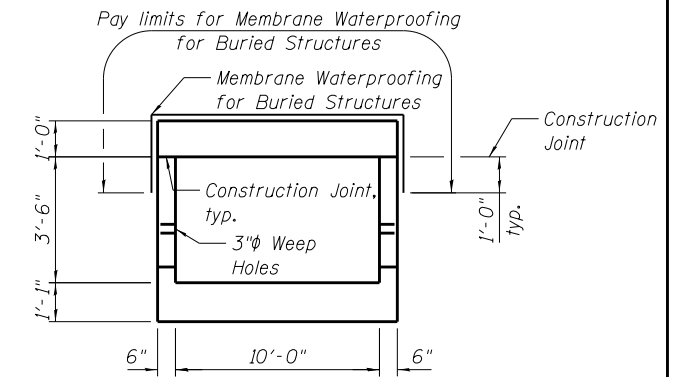

MEMBRANE WATERPROOFING FOR CAST-INPLACE BOX CULVERT

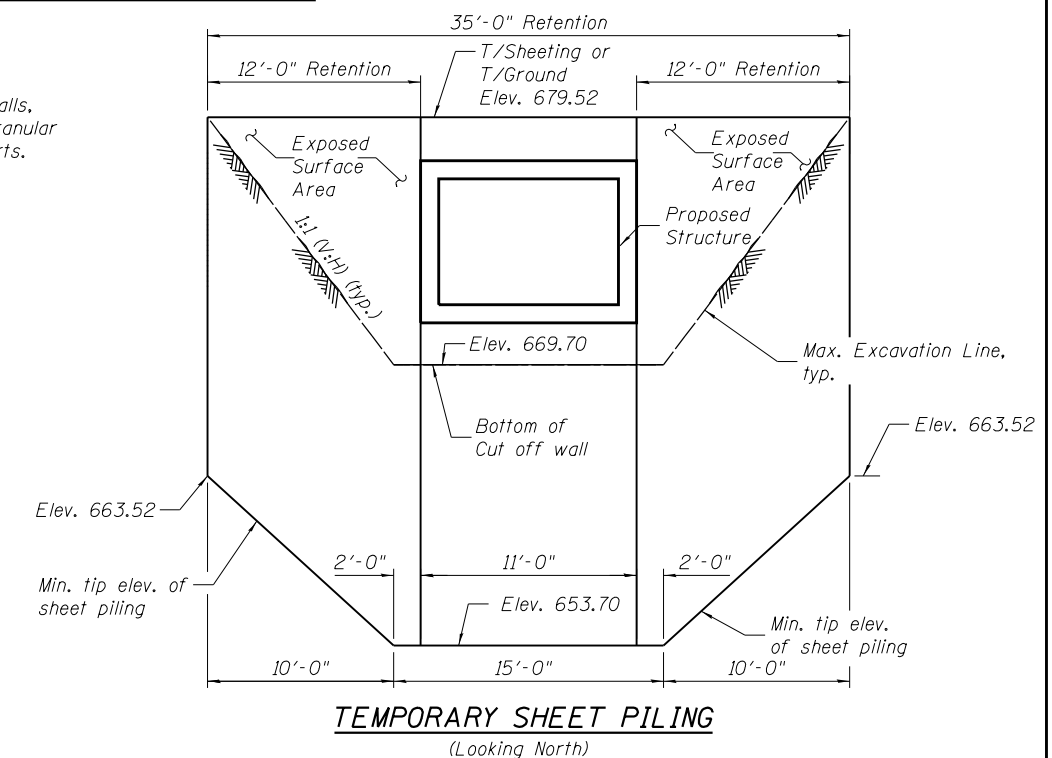

TEMPORARY SHEET PILING

(Looking North)

FILE NAME = Q:\Engineering\LiveProjects\13003 IDOT DURV130033 - WD 4 Contract No. 60Y26-CADD-CADD Sheets\Structural\016-1402-60Y26-INDXSHST(C)CON.dgn



USER NAME = johnn	DESIGNED - SAT	REVISED
PLOT SCALE = 1/8" = 1' - 0"	CHECKED - JMT	REVISED
PLOT DATE = 2/2/2018	DRAWN - JN	REVISED
	CHECKED - JMT	REVISED

**STATE OF ILLINOIS
DEPARTMENT OF TRANSPORTATION**

INDEX OF SHEETS, TOTAL BILL OF MATERIAL & CONSTRUCTION STAGING
STRUCTURE NO. 016-2282
SHEET NO. 2 OF 6 SHEETS

F.A.U. RTE.	SECTION	COUNTY	TOTAL SHEETS	SHEET NO.
0297	3178G-N14	COOK	151	103

CONTRACT NO. 60Y26
ILLINOIS FED. AID PROJECT

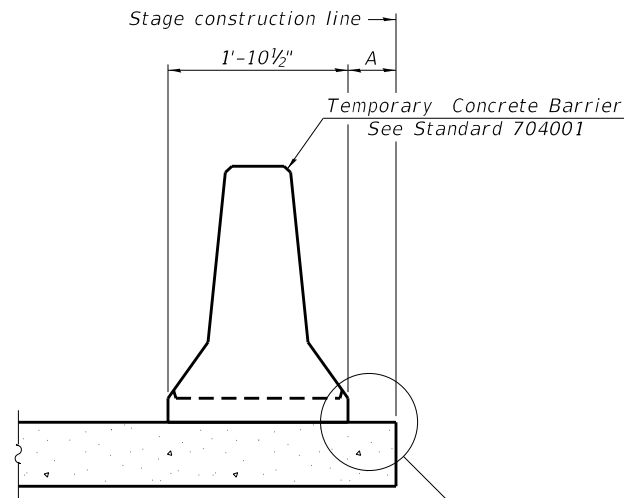

When "A" is 3'-1" or less, the temporary concrete barrier shall be restrained to the new slab according to Detail I, II or III. No restraint is required when "A" is greater than 3'-1".

NEW SLAB OR NEW DECK BEAM

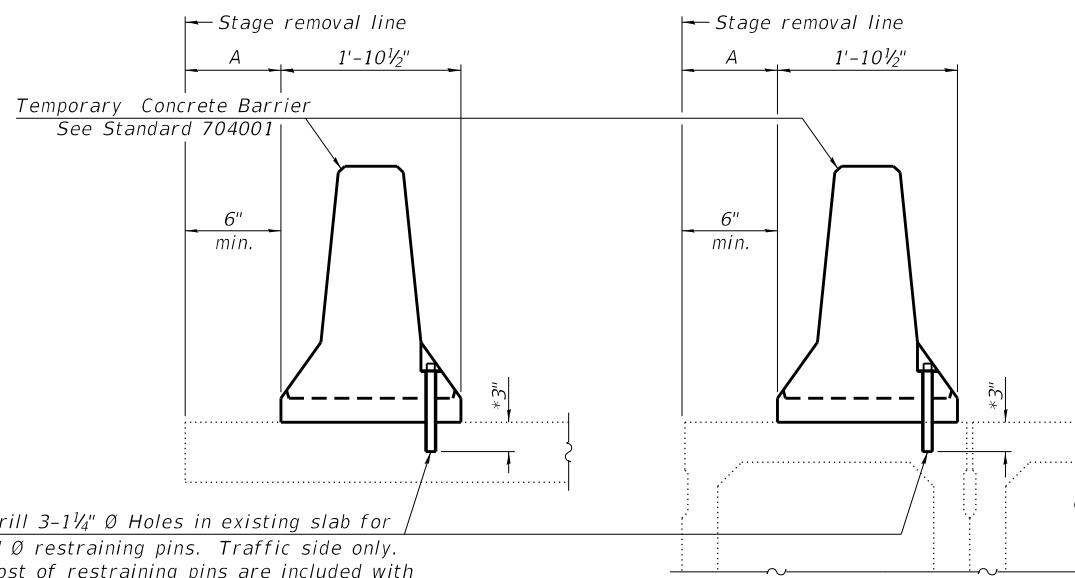

Drill 3-1/4" Ø Holes in existing slab for 1" Ø restraining pins. Traffic side only. Cost of restraining pins are included with Temporary Concrete Barrier. No restraint is required when "A" is greater than 3'-1".

EXISTING SLAB

* When hot-mix asphalt wearing surface is present, embedment shall be 3" plus the wearing surface depth.

EXISTING DECK BEAM

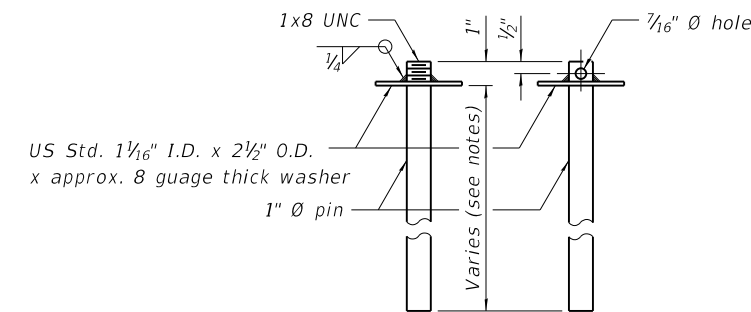

RESTRAINING PIN

SECTIONS THRU SLAB OR DECK BEAM

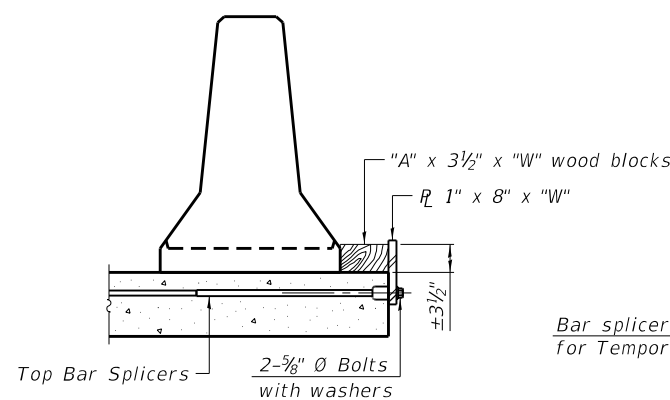

DETAIL I

Bar splicers and additional splicers for Temporary Concrete Barrier

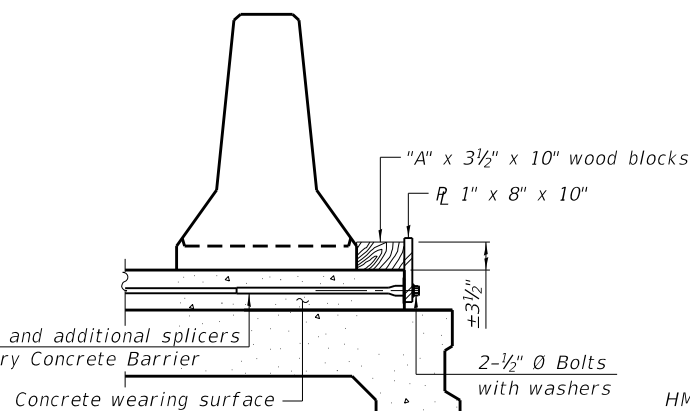

DETAIL II

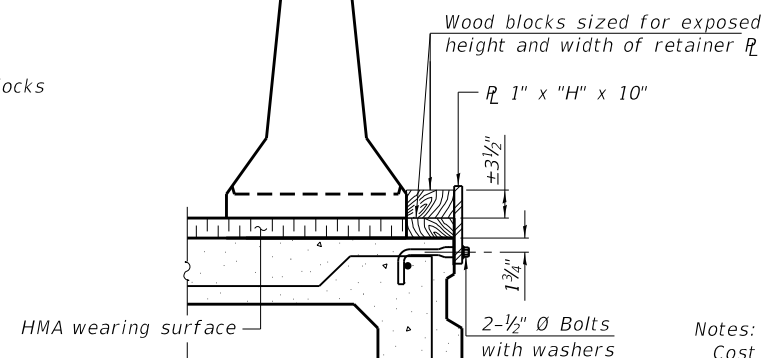

DETAIL III

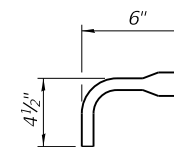

BAR SPLICER FOR #4 BAR - DETAIL III

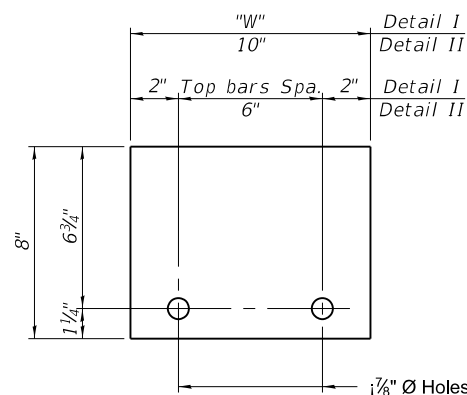

STEEL RETAINER 1" x 8" x "W"
(Detail I and II)

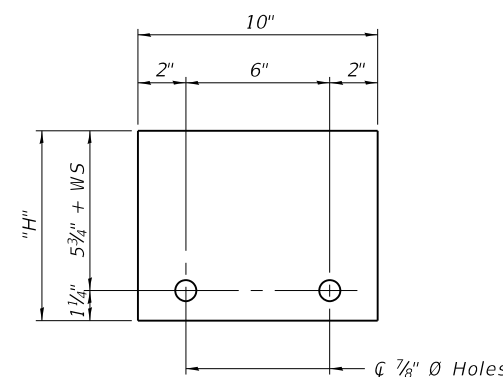

STEEL RETAINER 1" x "H" x 10"
(Detail III)

Notes:
 Cost of retainer assembly is included with Temporary Concrete Barrier.
 A retainer assembly shall be located at the approximate center of each temporary concrete barrier.
 The retainer plate shall not be removed until the concrete on the adjacent stage is ready to be poured. For Detail III applications the retainer plate shall not be removed until just prior to placing the adjacent beam.
 When the 'A' dimension is less than 1 1/2', the wood block shall be omitted and the barrier shall be placed in direct contact with the steel retainer plate. For deck beam applications the minimum required 'A' distance is 6" to accommodate the shear key clamping device.

- Detail I - Installation for a new bridge deck or bridge slab.
- Detail II - Installation for a new deck beam with an initial concrete wearing surface. Additional bar splicers shall be provided at 6'-0" centers and paired with the bar splicers of the concrete wearing surface reinforcement to accommodate the installation of the retainer assemblies. The cost of the additional bar splicers is included with the concrete wearing surface.
- Detail III - Installation for a new deck beam with no initial wearing surface or with an initial hot-mix asphalt (HMA) wearing surface present. The deck beam directly beneath the temporary concrete barrier shall be fabricated with bar splicer inserts in the side of the beam, as detailed, to accommodate the installation of the retainer assemblies. A pair of bar splicers, 6" apart, shall be placed at 6'-0" centers along the length of the beam. The cost of the bar splicers is included with the deck beam.

R-27 2-17-2017



USER NAME = johnn	DESIGNED - AB	REVISED
	CHECKED - SAT	REVISED
PLOT SCALE = 0:2' = 1"	DRAWN - JN	REVISED
PLOT DATE = 2/2/2018	CHECKED - JMT	REVISED

STATE OF ILLINOIS
DEPARTMENT OF TRANSPORTATION

TEMPORARY CONCRETE BARRIER FOR STAGE CONSTRUCTION
STRUCTURE NO. 016-2282

SHEET NO. 3 OF 6 SHEETS

F.A.U. RTE.	SECTION	COUNTY	TOTAL SHEETS	SHEET NO.
0297	3178G-N(14)	COOK	151	104
CONTRACT NO. 60Y26				
ILLINOIS FED. AID PROJECT				

FILE NAME = Q:\Engineering\LiveProjects\13003 IDOT DURV\3003d - WD 4 Contract No. 60Y26\CADD\CADD Sheets\Structural\016-1402-60Y26-TEMPCONBAR.dgn

FILE NAME = Q:\Engineering\Live\Projects\13003 IDOT DURV\3003d - WD 4 Contract No. 60Y26\CADD\CADD Sheets\Structural\016-1482-60Y26-CULVERT DETAILS.dgn

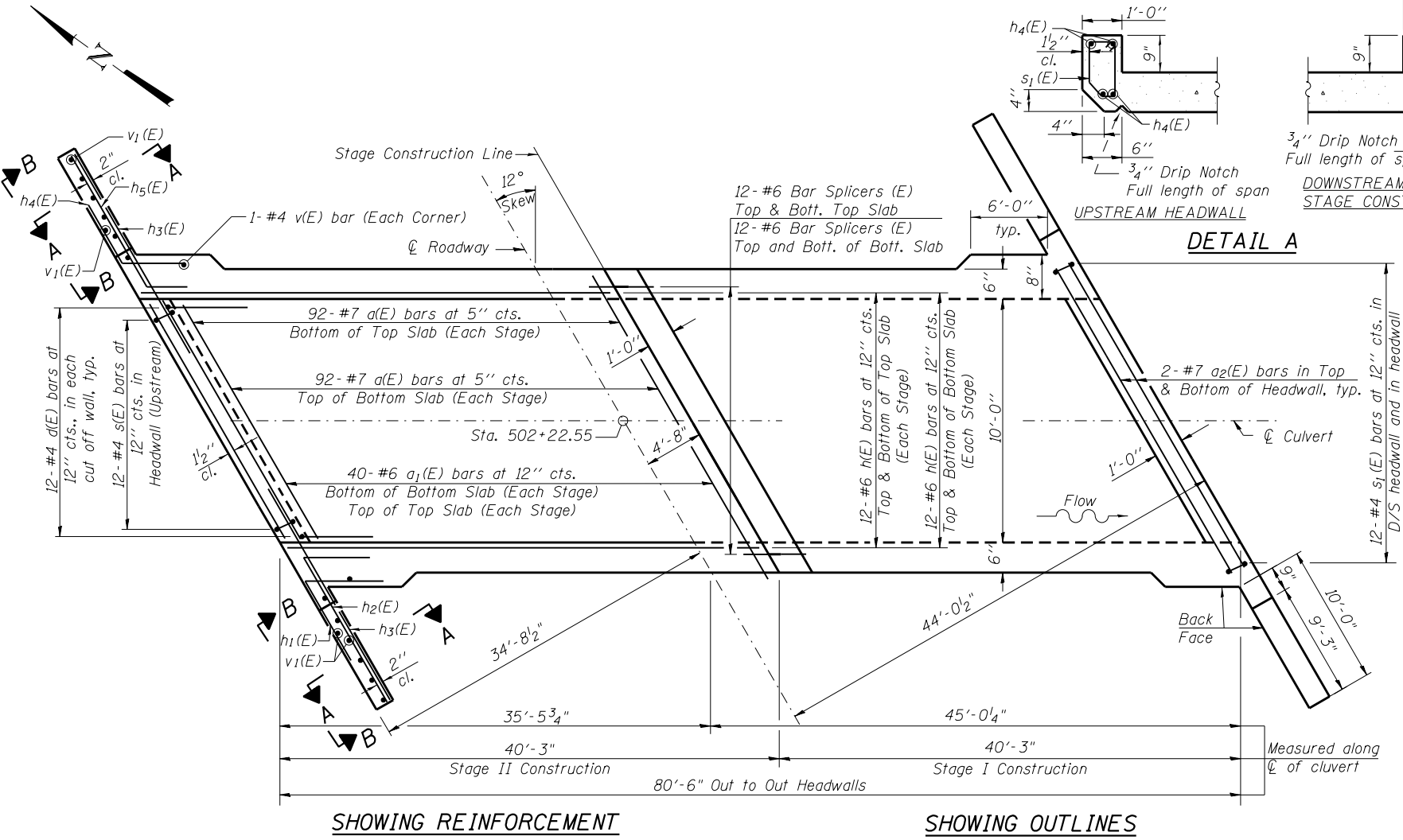
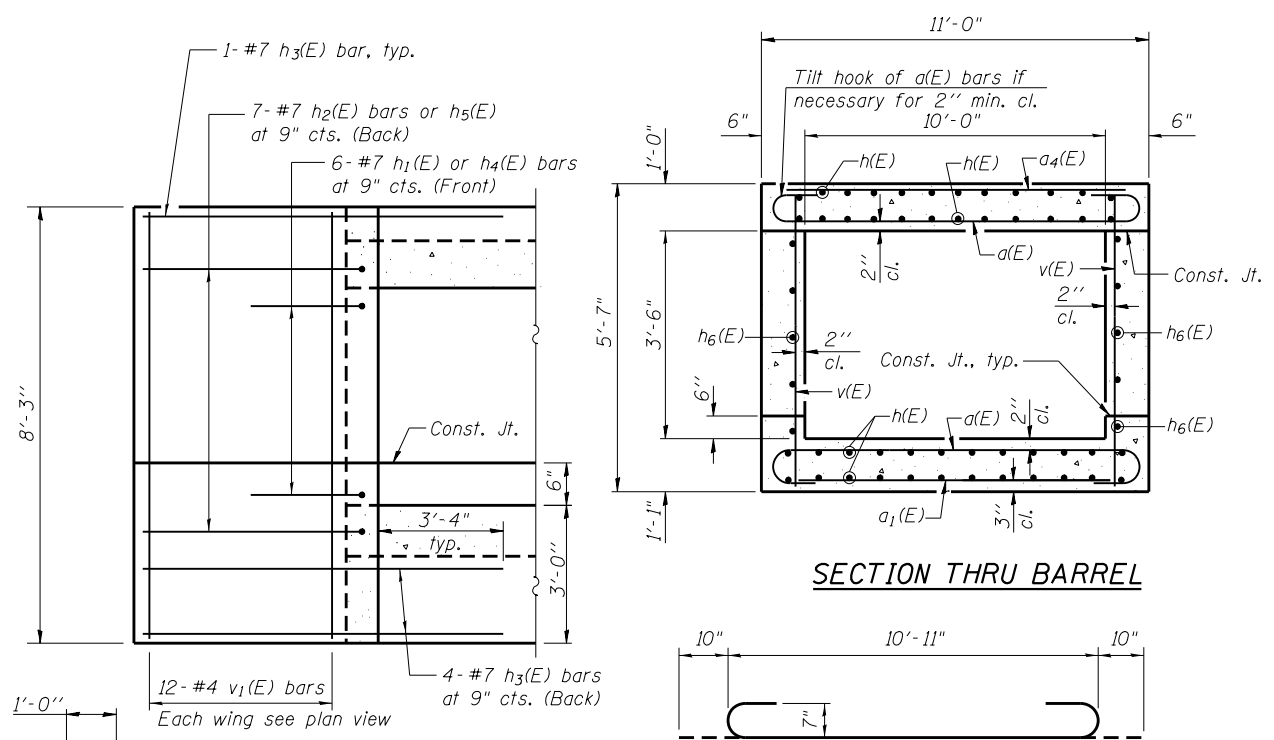
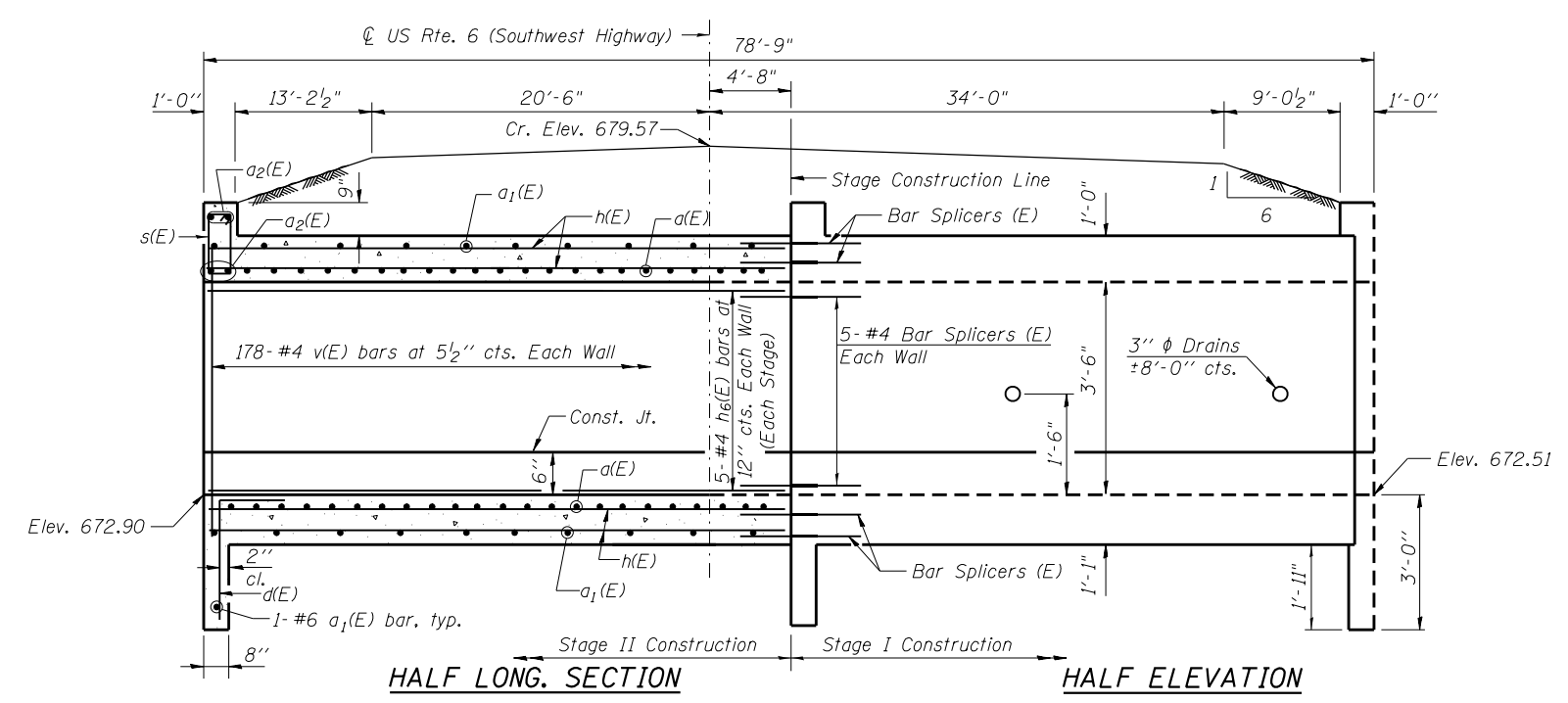

NOTES

- At least six feet of the barrel shall be poured monolithically with the wingwalls.

SECTION B-B

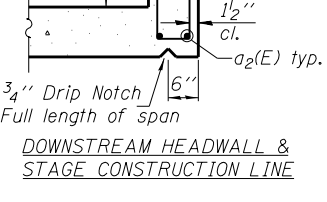

SECTION A-A

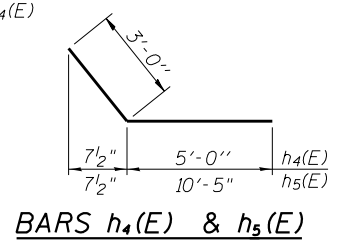
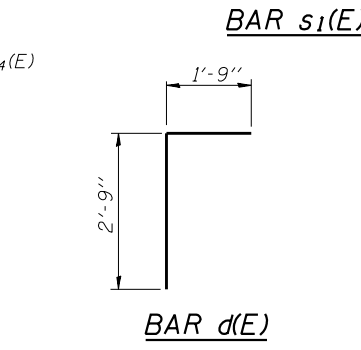
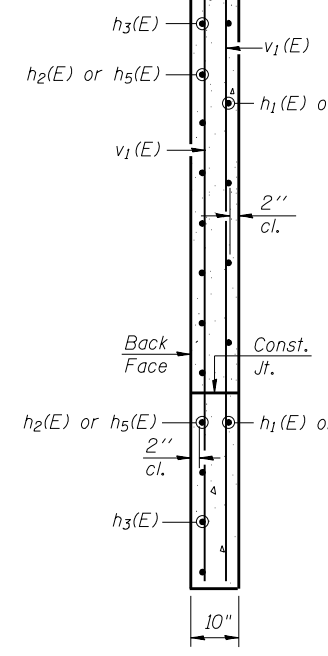

BAR a(E)

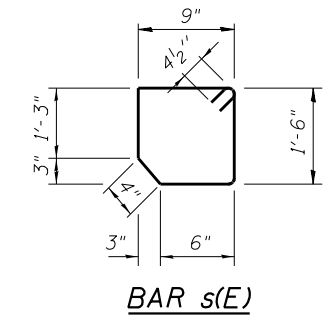

BILL OF MATERIAL

Bar	No.	Size	Length	Shape	
a(E)	368	#7	12'-7"	U	
a1(E)	163	#6	10'-11"	—	
a2(E)	12	#7	10'-11"	—	
d(E)	36	#4	4'-6"	U	
h(E)	96	#6	39'-11"	—	
h1(E)	12	#7	8'-0"	—	
h2(E)	14	#7	13'-5"	—	
h3(E)	20	#7	13'-11"	—	
h4(E)	12	#7	8'-0"	—	
h5(E)	14	#7	13'-5"	—	
h6(E)	20	#4	39'-11"	—	
s(E)	12	#4	4'-9"	U	
s1(E)	24	#4	5'-3"	U	
v(E)	360	#4	5'-3"	—	
v1(E)	48	#4	7'-11"	—	
Reinforcement Bars, Epoxy Coated				Pound	22,180
Concrete Box Culverts				Cu. Yd.	92.5



USER NAME = johnn	DESIGNED - AB	REVISED
PLOT SCALE = 0.2" = 1'	CHECKED - SAT	REVISED
PLOT DATE = 2/2/2018	DRAWN - JN	REVISED
	CHECKED - JMT	REVISED

**STATE OF ILLINOIS
DEPARTMENT OF TRANSPORTATION**

**CULVERT DETAILS
STRUCTURE NO. 016-2282**

F.A.U. RT. 0297	SECTION 3178G-N(14)	COUNTY COOK	TOTAL SHEETS 151	SHEET NO. 105
CONTRACT NO. 60Y26				ILLINOIS FED. AID PROJECT

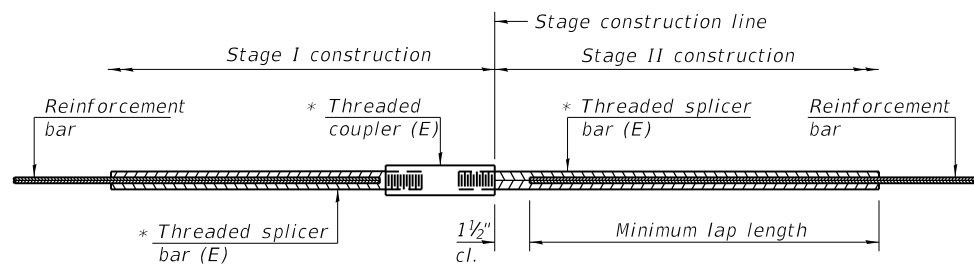

STANDARD BAR SPLICER ASSEMBLY

Threaded splicer bar length = min. lap length + 1 1/2" + thread length

* Epoxy not required on Bar Splicer Assembly components used in conjunction with black bars.

Location	Bar size	No. assemblies required	Minimum lap length
Top Slab	#6	24	3'-10"
Sidewalk	#4	10	2'-7"
Bottom Slab	#6	24	3'-10"

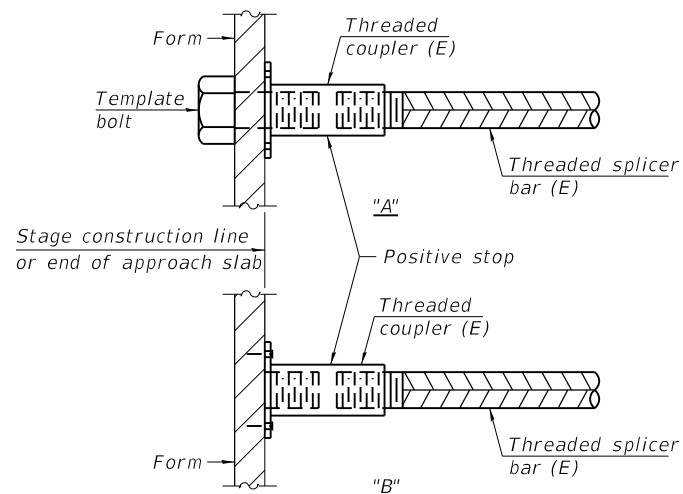

INSTALLATION AND SETTING METHODS

"A" : Set bar splicer assembly by means of a template bolt.
 "B" : Set bar splicer assembly by nailing to wood forms or cementing to steel forms.
 (E) : Indicates epoxy coating.

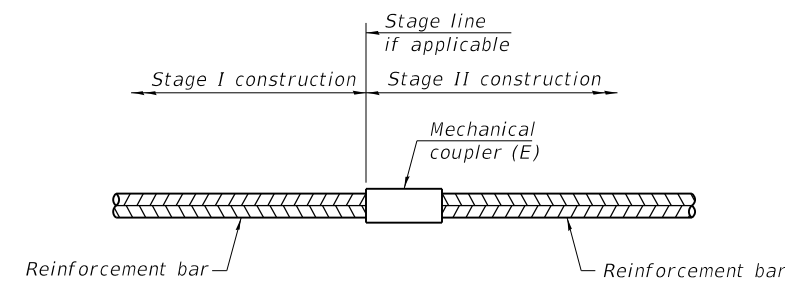

STANDARD MECHANICAL SPLICER

Location	Bar size	No. assemblies required

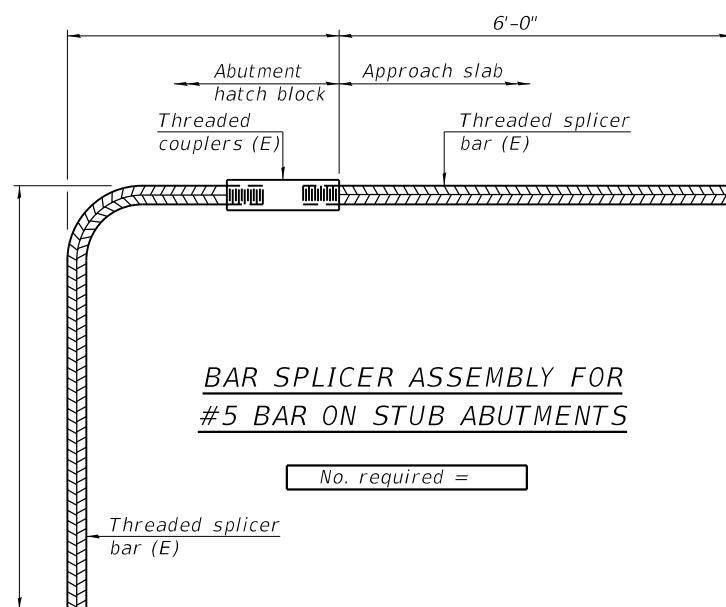

BAR SPLICER ASSEMBLY FOR #5 BAR ON STUB ABUTMENTS

NOTES

Splicer bars shall be deformed with Threaded ends and have a minimum 60 ksi yield strength.
 All reinforcement shall be lapped and tied to the splicer bars.
 Bar splicer assemblies shall be epoxy coated according to the requirements for reinforcement bars. See Section 508 of the Standard Specifications.
 See approved list of bar splicer assemblies and mechanical splicers for alternatives.

FILE NAME = Q:\Engineering\LiveProjects\13003 IDOT DUR\13003d - WD 4 Contract No. 60Y26-CADD\CADD Sheets\Structural\016-1402-60Y26-BARSPLICER.dgn

BSD-1

2-17-2017



USER NAME = johnn	DESIGNED - AB	REVISED
	CHECKED - SAT	REVISED
PLOT SCALE = 0:2' = 1" / in.	DRAWN - JN	REVISED
PLOT DATE = 2/2/2018	CHECKED - JMT	REVISED

STATE OF ILLINOIS
DEPARTMENT OF TRANSPORTATION

BAR SPLICER ASSEMBLY AND MECHANICAL SPLICER DETAILS
STRUCTURE NO. 016-2282

SHEET NO. 5 OF 6 SHEETS

F.A.U. RTE.	SECTION	COUNTY	TOTAL SHEETS	SHEET NO.
0297	3178G-N(14)	COOK	151	106
CONTRACT NO. 60Y26				
ILLINOIS FED. AID PROJECT				

Wang Engineering
 wangeng@wangeng.com
 1145 N Main Street
 Lombard, IL 60148
 Telephone: 630 953-9928
 Fax: 630 953-9938

BORING LOG CB-01
 WEI Job No.: 491-01-02
 Client: **Accurate Group, Inc.**
 Project: **US Route 6 Culvert at 179th Street**
 Location: **Sections 31, T 36 N, R 12E of the 3rd P.M.**

Datum: NGVD
 Elevation: 678.90 ft
 North: 1784173.63 ft
 East: 1101740.22 ft
 Station: 502+09.74
 Offset: 16.79 RT

Profile Elevation (ft)	SOIL AND ROCK DESCRIPTION	Depth (ft)	Sample No.	SPT Values (blows/in)	Qu (tsf)	Moisture Content (%)	Profile Elevation (ft)	SOIL AND ROCK DESCRIPTION	Depth (ft)	Sample No.	SPT Values (blows/in)	Qu (tsf)	Moisture Content (%)
678.6	8-inch thick ASPHALT --PAVEMENT--						653.4	Very stiff, gray SILTY CLAY LOAM, trace gravel					
677.6	4-inch thick CRUSHED STONE --BASE COURSE--												
	Stiff to very stiff, brown and gray SILTY CLAY LOAM	1	4	3	2.00	25			11	7	6	2.54	15
	--FILL--												
674.4	Loose, dark brown SILTY LOAM	2	2	3	1.75	29			12	5	5	2.38	14
	--FILL--												
673.4	Stiff to very stiff, brown and gray SILTY CLAY to SILTY CLAY LOAM, trace to little gravel	3	3	3	1.15	18							
	--Wet-- --Possible sand layer--												
		4	2	3	2.87	26							
		5	4	5	2.46	22							
		6	5	7	3.12	20							
		7	5	7	3.03	17							
		8	4	7	1.80	19							
		9	4	5	1.48	18							
658.4	Stiff, gray CLAY, trace gravel												
		10	3	5	1.00	17							

GENERAL NOTES				WATER LEVEL DATA			
Begin Drilling	05-29-2014	Complete Drilling	05-29-2014	While Drilling	8.00 ft		
Drilling Contractor	WTS	Drill Rig	CME 55	At Completion of Drilling	5.00 ft		
Driller	R&N	Logger	D. Kolpacki	Checked by	A. Kurnia		
Drilling Method	2.25" SSA, 2.5' Interval to 30', boring backfilled upon completion			Time After Drilling	NA		
				Depth to Water	NA		
				The stratification lines represent the approximate boundary between soil types; the actual transition may be gradual.			

Wang Engineering
 wangeng@wangeng.com
 1145 N Main Street
 Lombard, IL 60148
 Telephone: 630 953-9928
 Fax: 630 953-9938

BORING LOG CB-02
 WEI Job No.: 491-01-02
 Client: **Accurate Group, Inc.**
 Project: **US Route 6 Culvert at 179th Street**
 Location: **Sections 31, T 36 N, R 12E of the 3rd P.M.**

Datum: NGVD
 Elevation: 678.85 ft
 North: 1784236.26 ft
 East: 1101751.18 ft
 Station: 502+60.83
 Offset: 21.06 LT

Profile Elevation (ft)	SOIL AND ROCK DESCRIPTION	Depth (ft)	Sample No.	SPT Values (blows/in)	Qu (tsf)	Moisture Content (%)	Profile Elevation (ft)	SOIL AND ROCK DESCRIPTION	Depth (ft)	Sample No.	SPT Values (blows/in)	Qu (tsf)	Moisture Content (%)
678.6	15-inch-thick ASPHALT --PAVEMENT--						653.3	Medium dense, gray LOAM					
677.6	3-inch thick SANDY GRAVEL												
	Very stiff, brown SILTY CLAY LOAM, trace gravel	1	3	3	3.50	19			11	5	5	NP	26
	--FILL--												
675.5	Loose, dark black and brown SILTY LOAM	2	3	3	NP	22			12	3	5	1.39	17
	--FILL--												
673.3	Stiff, brown SILTY CLAY, trace gravel												
	Stiff to hard, brown and gray SILTY CLAY, trace gravel	3	3	3	1.80	24							
	--WET--												
	-L ₁ (%)=47, P ₁ (%)=21- -%Gravel=0.1- -%Sand=8.6-10 -%Silt=50.3- -%Clay=41.0-	4	3	3	1.64	31							
		5	3	4	4.76	21							
		6	4	10	5.08	21							
		7	4	6	3.44	12							
		8	4	6	2.30	17							
		9	6	7	NP	26							
658.3	Medium dense, gray SANDY GRAVEL												
	--WET--												
655.8	Very stiff, gray SILTY CLAY, trace gravel												
		10	5	5	2.00	28							

GENERAL NOTES				WATER LEVEL DATA			
Begin Drilling	05-29-2014	Complete Drilling	05-29-2014	While Drilling	24.50 ft		
Drilling Contractor	WTS	Drill Rig	CME 55	At Completion of Drilling	24.50 ft		
Driller	R&N	Logger	D. Kolpacki	Checked by	A. Kurnia		
Drilling Method	2.25" SSA, 2.5' Interval to 30', boring backfilled upon completion			Time After Drilling	NA		
				Depth to Water	NA		
				The stratification lines represent the approximate boundary between soil types; the actual transition may be gradual.			

FILE NAME = Q:\Engineering\LiveProjects\13003 IDOT DUV\13003\3D - W0 4 Contract No. 60Y26\CADD\CADD Sheets\Structural\016-1402-60Y26-BORING LOG.dgn



USER NAME = johnn	DESIGNED -	REVISED
	CHECKED -	REVISED
PLOT SCALE = 0.1667' / in.	DRAWN -	REVISED
PLOT DATE = 2/2/2018	CHECKED -	REVISED

STATE OF ILLINOIS
 DEPARTMENT OF TRANSPORTATION

BORING LOGS
 STRUCTURE NO. 016-2282
 SHEET NO. 6 OF 6 SHEETS

F.A.U. RTE.	SECTION	COUNTY	TOTAL SHEETS	SHEET NO.
Q297	3178G-N14)	COOK	151	107
CONTRACT NO. 60Y26				
ILLINOIS FED. AID PROJECT				

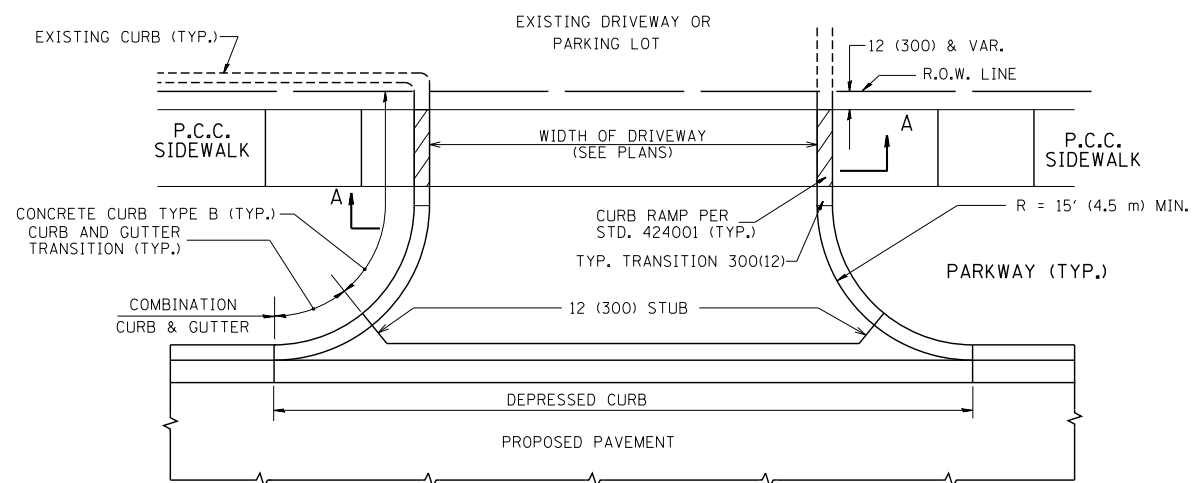

WITH CONCRETE CURB, TYPE B

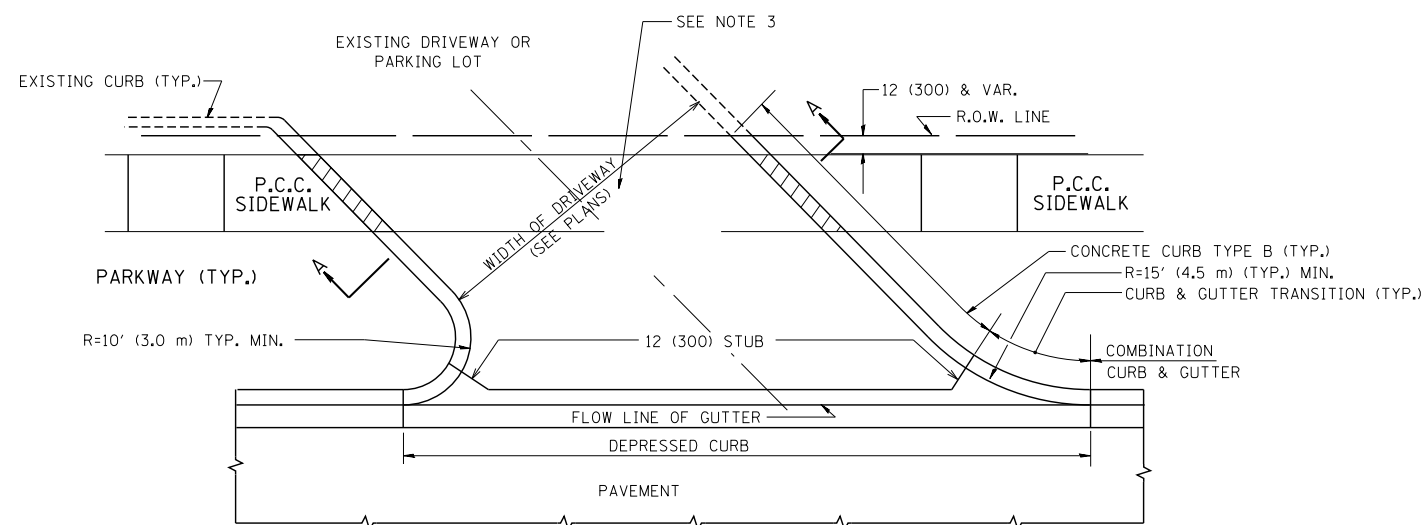

WITH CONCRETE CURB, TYPE B

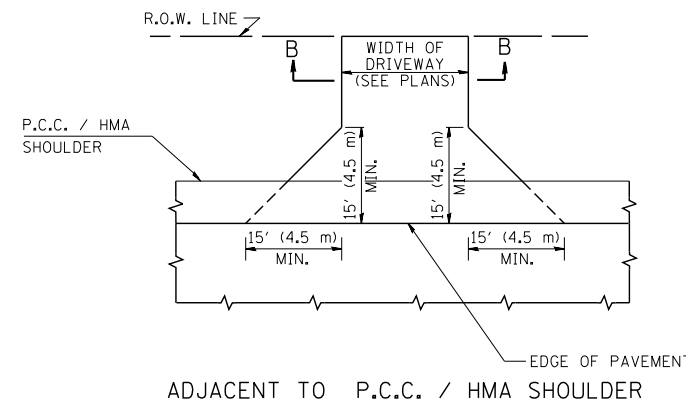
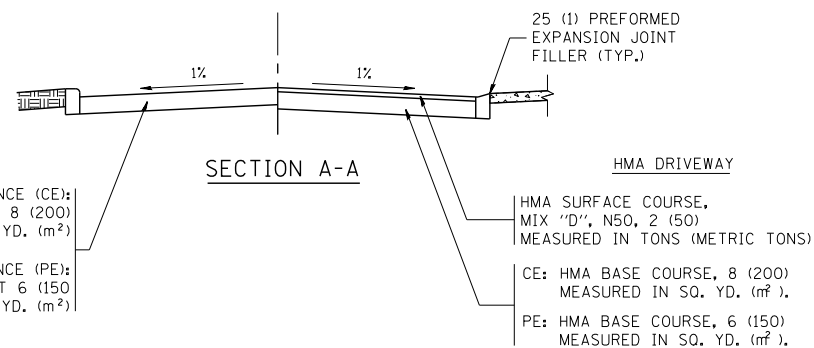

ADJACENT TO P.C.C. / HMA SHOULDER

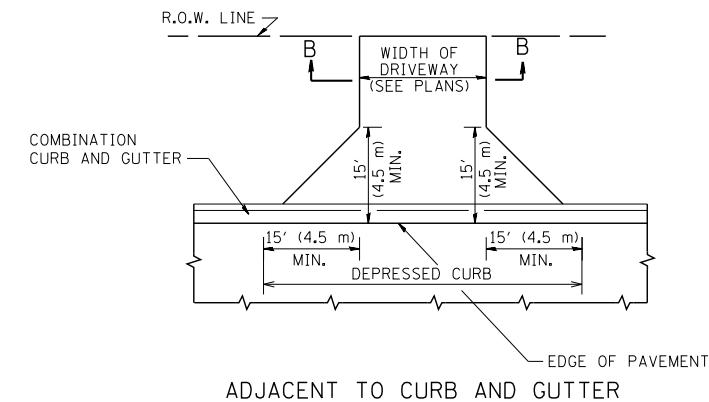

ADJACENT TO CURB AND GUTTER

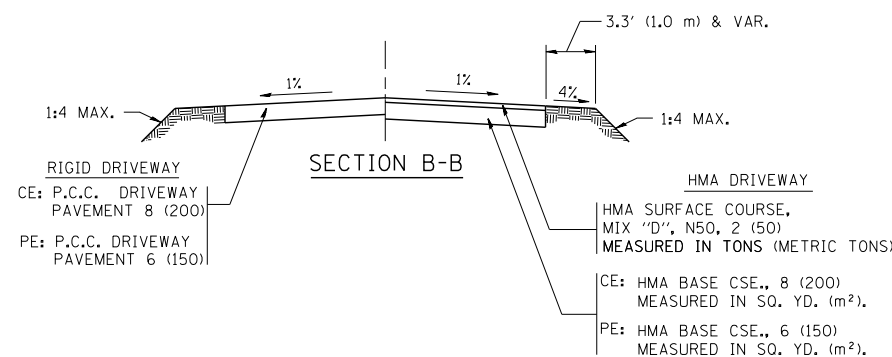

RURAL FIELD ENTRANCE (FE)
HMA SURFACE COURSE,
MIX 'D', N50, 2 (50)
MEASURED IN TONS (METRIC TONS)
AGGREGATE BASE CSE., TYPE B, 8 (200)
MEASURED IN SQ. YD. (m²).

GENERAL NOTES:

DRIVEWAY SLOPES, LOCATIONS, & GEOMETRIC LAYOUT SHALL BE IN ACCORDANCE WITH THE LATEST EDITION OF THE "HANDBOOK FOR POLICY ON PERMITS FOR ACCESS DRIVEWAYS TO STATE HIGHWAYS". FOR FURTHER LAYOUT REQUIREMENTS, REFER TO ILLUSTRATIONS IN THE PERMIT HANDBOOK. DRIVEWAYS SHALL BE REPLACED IN KIND, UNLESS OTHERWISE NOTED ON THE PLANS.

COMMERCIAL DRIVEWAYS SHALL BE CONSTRUCTED WITH CONCRETE CURB, TYPE B RETURNS EXCEPT WHEN THE SIDEWALK EDGE IS 4 FEET (1.2 METERS) OR LESS FROM THE BACK OF CURB, CONSTRUCT A FLARE DRIVEWAY WITHOUT CURB.

THE RESIDENT ENGINEER SHALL CONTACT THE TRAFFIC PERMIT OFFICE AT 847/ 705-4131 FOR ANY QUESTIONS ON DRIVEWAYS SHOWN IN THE PLANS; SPECIFICALLY IN REFERENCE TO ADDITIONAL AND/OR RELOCATION/REMOVAL OF A DRIVEWAY.

COMBINATION CONCRETE CURB & GUTTER SHALL BE MEASURED STRAIGHT ACROSS THE DRIVEWAY. NO ADDITIONAL COMPENSATION WILL BE ALLOWED FOR THE CURB & GUTTER TRANSITION.

1 (25) PREFORMED EXPANSION JOINT FILLER WILL NOT BE PAID SEPARATELY, BUT SHALL BE CONSIDERED INCLUDED IN THE COST OF THE P.C.C. DRIVEWAY PAVEMENT OR P.C.C. SIDEWALK.

WHEN THE P.C.C. SIDEWALK EXTENDS THROUGH THE DRIVEWAY, THE THICKNESS OF THE SIDEWALK IN THE DRIVEWAY AREA SHALL BE THE SAME AS THE DRIVEWAY THICKNESS. SIDEWALK WILL BE PAID FOR AS P.C.C. SIDEWALK OF THE THICKNESS SPECIFIED. SIDEWALK CROSS SLOPE THRU DRIVEWAY AREA TO BE A MAXIMUM OF 1:50.

FILE NAME =	USER NAME = l1eyso	DESIGNED - R. SHAH	REVISED - P. LaFLUER 04-15-03
ct:\pw\work\p1dot\1eyso\d0108315\bd01.dgn		DRAWN -	REVISED - R. BORO 01-01-07
	PLOT SCALE = 50.0000' / in.	CHECKED -	REVISED - R. BORO 06-11-08
	PLOT DATE = 9/6/2011	DATE - 11-04-95	REVISED - R. BORO 09-06-11

**STATE OF ILLINOIS
DEPARTMENT OF TRANSPORTATION**

**DRIVEWAY DETAILS - DISTANCE BETWEEN R.O.W.
AND FACE OF CURB & EDGE OF SHOULDER >= 15' (4.5 m)**

SCALE: NONE SHEET NO. 1 OF 1 SHEETS STA. TO STA.

FAU. RTE.	SECTION	COUNTY	TOTAL SHEETS	SHEET NO.
0297	3178G-N(14)	COOK	151	108
BD0156-07 (BD-01)		CONTRACT NO.	60Y26	
FED. ROAD DIST. NO. 1 ILLINOIS FED. AID PROJECT				

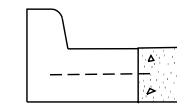
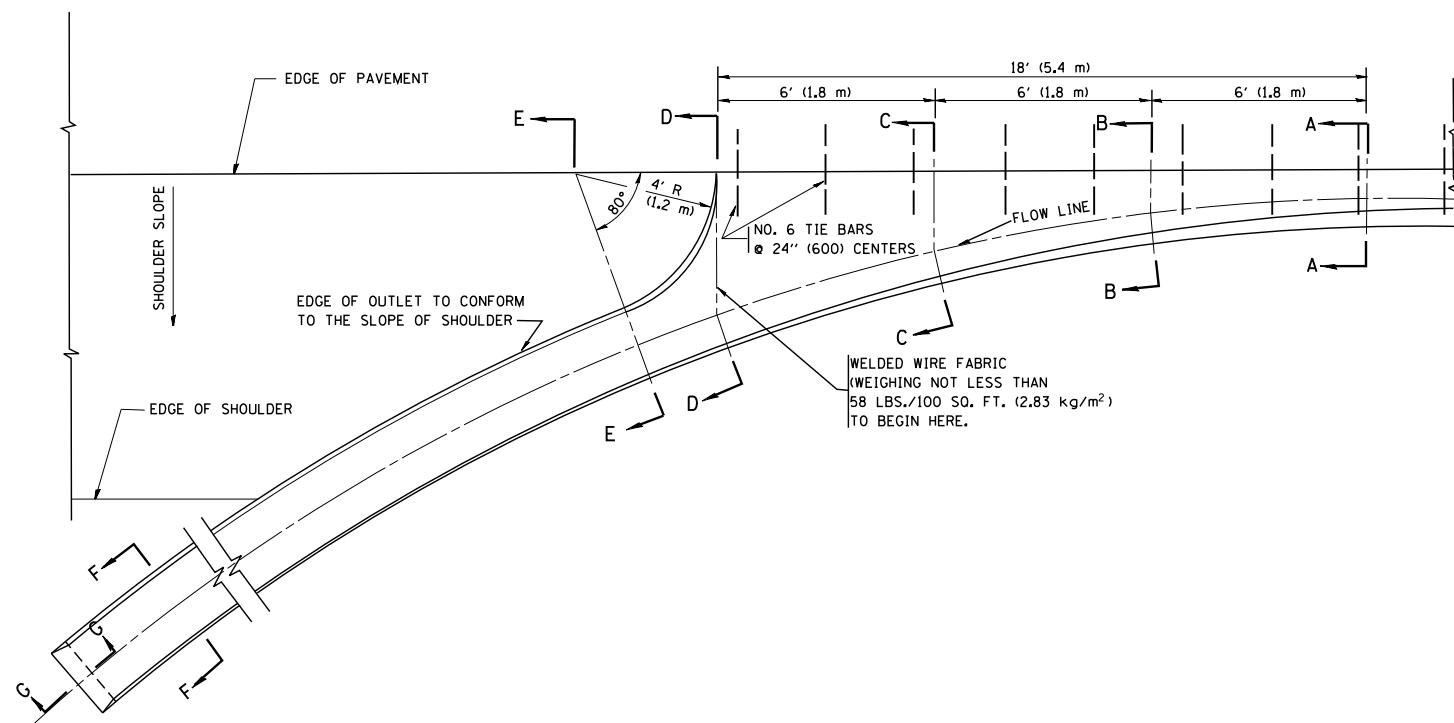

A-A *

* DIMENSIONS OF THE CURB & GUTTER AT SECTION A-A ARE SHOWN ON STATE STANDARD 606001. FOR DETAILS OF OUTLET FOR CONCRETE CURB & GUTTER, TYPE B-6.24 (B-15.60) SEE STATE STANDARD 606006.

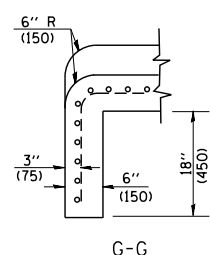
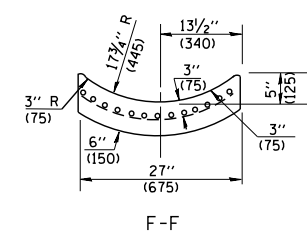
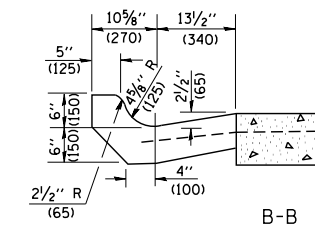
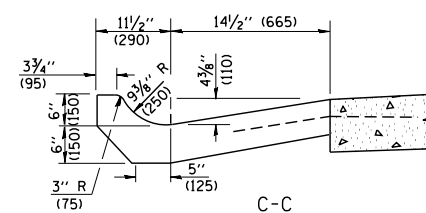
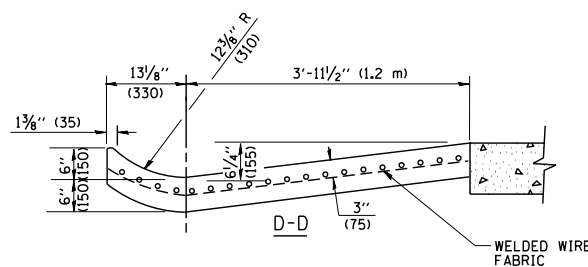
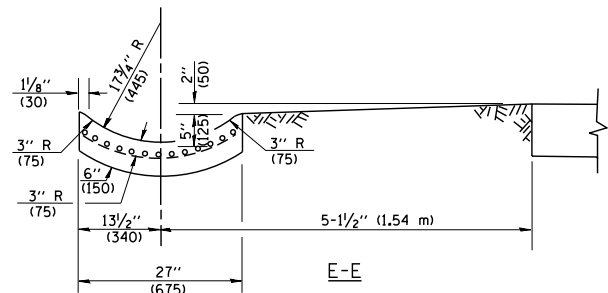

GENERAL NOTES

GUTTER OUTLET SHALL BE TIED TO THE PAVEMENT IN ACCORDANCE WITH DETAILS FOR LONGITUDINAL CONSTRUCTION JOINT SHOWN ON STANDARD 420001.

TIE BARS SHALL BE NO. 20 (NO.6) AT 24\"/>

IF THE AVERAGE GRADE OF PAVEMENT FOR THE DISTANCE FROM SECTION A-A TO D-D EXCEEDS 2%, THIS DISTANCE SHALL BE INCREASED 6' (1.8 m) FOR EACH 1% INCREASE IN GRADE.

QUANTITIES

FOR SECTION A-A TO E-E AND CURTAIN WALL =
 1.25 CU. YDS. (0.96 m³) CLASS S1 CONCRETE (OUTLET) FOR 9\"/>

ALL DIMENSIONS ARE IN INCHES (MILLIMETERS) UNLESS OTHERWISE SHOWN.

FILE NAME = W:\diststd\22x34\bd03.dgn	USER NAME = gaglionobt	DESIGNED - M. DE YONG	REVISED - R. SHAH 09-09-94	STATE OF ILLINOIS DEPARTMENT OF TRANSPORTATION	OUTLET FOR CONCRETE CURB AND GUTTER			FAU. RTE. 0297	SECTION 3178G-N(14)	COUNTY COOK	TOTAL SHEETS 151	SHEET NO. 109
	PLOT SCALE = 50.0000 ' / IN.	CHECKED -	REVISED - R. SHAH 10-25-94					BD600-01 (BD-03)	CONTRACT NO. 60Y26			
PLOT DATE = 1/4/2008	DATE - 08-04-86	REVISED - E. GOMEZ 12-21-00	REVISED -	SCALE: NONE	SHEET NO. 1 OF 1 SHEETS	STA. TO STA.	FED. ROAD DIST. NO. 1 ILLINOIS FED. AID PROJECT					

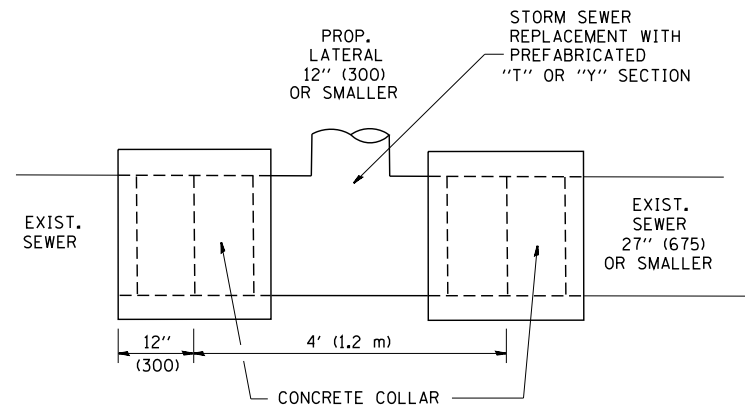

DETAIL "A"

LATERAL CONNECTION TO EXISTING SEWER OF 27" (675) OR SMALLER

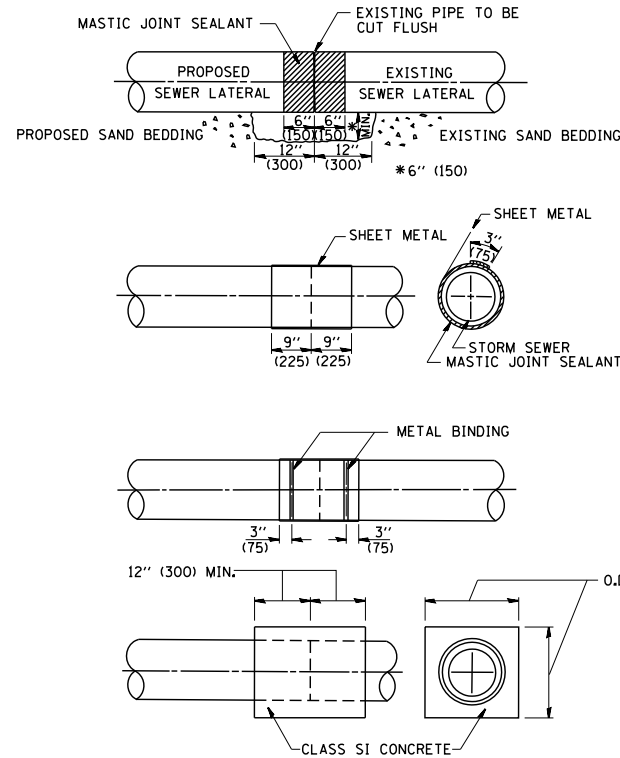

DETAIL "B"

CLASS SI CONCRETE COLLAR

CONSTRUCTION SEQUENCE

- CUT THE EXISTING END OF THE PIPE SO AS TO PRESENT A FLUSH BUTT JOINT. BRUSH AND CLEAN ALL PIPES.
- APPLY THE MASTIC JOINT SEALANT TO THE FIRST 6" (150) OF EACH PIPE.
- BUTT THE PIPES TOGETHER LEAVING A MINIMUM OF 12" x 6' (300 x 150) DEEP EXCAVATION UNDER AND AROUND EACH PIPE END.
- CUT A PIECE OF SHEET METAL GAGE NO. 19 1.1 (0.0418) 18" (450) WIDE BY THE OUTSIDE CIRCUMFERENCE OF THE PIPE PLUS 3" (75) LONG.
- WRAP THE SHEET METAL AROUND THE PIPES, 9" (225) ON EACH SIDE OF THE JOINT, STARTING AT THE TOP OF THE PIPE.
- LAP THE SHEET METAL AT LEAST 3" (75) AT THE TOP OF THE PIPE AND PLACE THE MASTIC JOINT SEALANT BETWEEN THE LAP.
- PLACE TWO METAL BANDS AROUND THE SHEET METAL AND TIGHTEN.
- WIPE OFF ANY EXCESS MASTIC JOINT SEALANT THAT OOOZES OUT FROM BETWEEN THE SHEET METAL AND THE PIPES.
- PLACE CLASS SI CONCRETE AROUND THE JOINT.

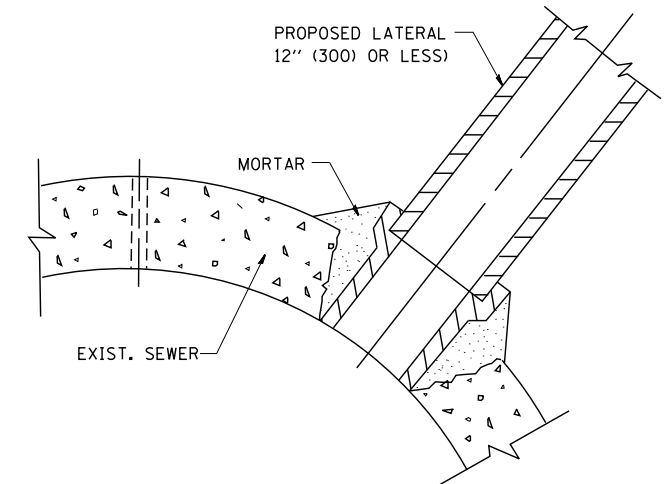

DETAIL "C"

PROPOSED LATERAL CONNECTION TO EXISTING SEWER OF 30" (750) OR LARGER

NOTES

MATERIAL

MATERIAL USED FOR THE TEE OR WYE SECTION SHALL BE COMPATIBLE WITH THE EXISTING STORM SEWER OR THE PROPOSED STORM SEWER.

CONSTRUCTION METHODS

- THIS WORK SHALL BE CONSTRUCTED IN CONFORMANCE WITH THE APPLICABLE PORTIONS OF SECTION 550 OF THE STANDARD SPECIFICATIONS.
- CONNECTION TO AN EXISTING STORM SEWER SHALL BE BY EITHER OF THE FOLLOWING METHODS:
 - PROPOSED STORM SEWER CONNECTION TO EXISTING SEWER OF 27" (675) OR SMALLER SEE DETAIL "A" AND "B".
 - PROPOSED STORM SEWER CONNECTION TO EXISTING SEWER OF 30" (750) OR LARGER SEE DETAIL "C".

IF THE EXISTING SEWER PIPE IS CRACKED, BROKEN OR OTHERWISE DAMAGED BY THE CONTRACTOR IN MAKING THE CIRCULAR OPENING, THE CONTRACTOR SHALL REPLACE THAT SECTION OF PIPE WITH PIPE EQUAL AND SIMILAR IN ALL RESPECTS TO THE PIPE IN THE EXISTING SEWER, IN A CAREFUL WORKMANLIKE MANNER, WITHOUT EXTRA COMPENSATION.

GENERAL

CARE MUST BE TAKEN TO PREVENT DEBRIS FROM ENTERING THE SEWER. ALL DEBRIS WHICH ENTERS THE SEWER MUST BE REMOVED. THE SEWER MUST BE LEFT CLEAN AND UNOBSTRUCTED UPON COMPLETION OF THE CONTRACT.

CARE MUST BE TAKEN TO PREVENT ANY PART OF THE NEW PIPE CONNECTION FROM PROJECTING INTO THE EXISTING SEWER.

BASIS OF PAYMENT

TEE OR WYE CONNECTIONS SHALL BE PAID FOR AT THE CONTRACT UNIT PRICE EACH FOR STORM SEWER TEE OR WYE OF THE TYPE AND SIZE SPECIFIED IN THE PLANS. THIS PRICE SHALL INCLUDE ALL EXCAVATION OF THE TRENCH, REMOVAL OF THE EXISTING STORM SEWER, FURNISHING AND INSTALLING THE SPECIFIED TEE OR WYE SECTION, FURNISHING AND INSTALLING THE REQUIRED CONCRETE COLLAR, AND ALL OTHER MATERIAL NECESSARY TO COMPLETE THIS WORK AS SHOWN AND SPECIFIED.

REMOVAL AND REINSTALLATION OF EXISTING STORM SEWER ADJACENT TO THE PROPOSED TEE OR WYE SECTION, FOR THE PURPOSE OF FACILITATING THE INSTALLATION OF THE TEE OR WYE SECTION, WILL NOT BE PAID FOR SEPARATELY BUT SHALL BE INCLUDED IN THE UNIT PRICE BID FOR THE WORK.

TRENCH BACKFILL, EXCAVATION IN ROCK AND REMOVAL AND REPLACEMENT OF UNSUITABLE MATERIAL BELOW PLAN BEDDING GRADE WILL BE PAID FOR SEPARATELY.

CONCRETE COLLAR FOR CONNECTING A PROPOSED STORM SEWER TO AN EXISTING STORM SEWER WILL NOT BE PAID FOR SEPARATELY BUT SHALL BE INCLUDED IN THE COST OF THE PROPOSED STORM SEWER.

ALL DIMENSIONS ARE IN INCHES (MILLIMETERS) UNLESS OTHERWISE SHOWN.

FILE NAME = W:\diststd\22x34\bd07.dgn	USER NAME = geglionbt	DESIGNED - M. DE YONG	REVISED - M. DE YONG 05-08-92
		DRAWN -	REVISED - R. SHAH 09-09-94
	PLOT SCALE = 50.000' / IN.	CHECKED -	REVISED - R. SHAH 10-25-94
	PLOT DATE = 1/4/2008	DATE - 07-25-90	REVISED - R. SHAH 06-12-96

STATE OF ILLINOIS
DEPARTMENT OF TRANSPORTATION

DETAIL OF STORM SEWER
CONNECTION TO EXISTING SEWER

SCALE: NONE SHEET NO. 1 OF 1 SHEETS STA. TO STA.

FAU. RTE. 0297	SECTION 3178G-N(14)	COUNTY COOK	TOTAL SHEETS 151	SHEET NO. 110
BD500-01 (BD-7)		CONTRACT NO. 60Y26		
FED. ROAD DIST. NO. 1 ILLINOIS FED. AID PROJECT				

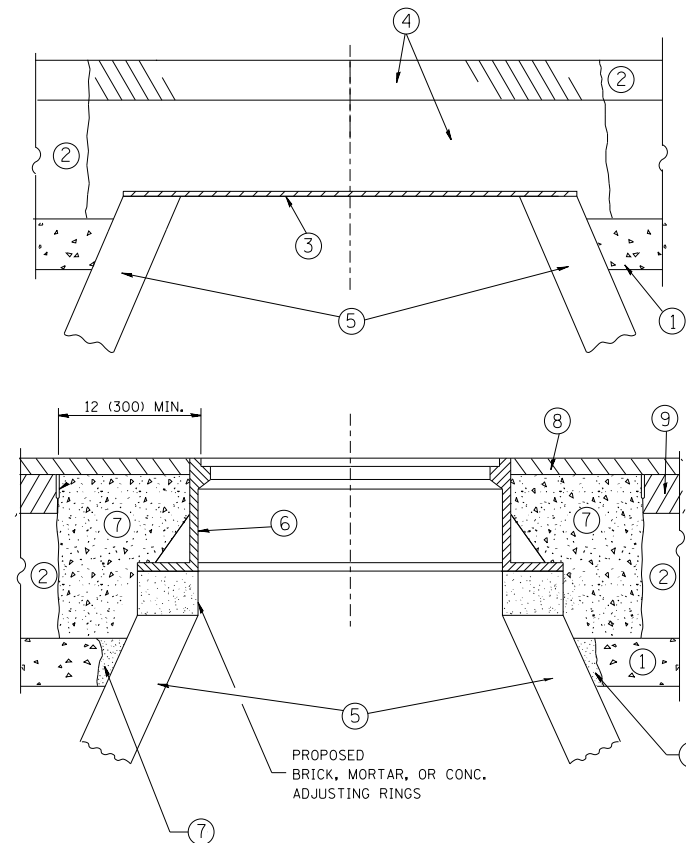

CONSTRUCTION PROCEDURES

STAGE 1 (BEFORE PAVEMENT MILLING)

- A) REMOVE A MINIMUM OF 12 (300) OF THE PAVEMENT FROM AROUND THE STRUCTURE.
- B) REMOVE THE EXISTING FRAME AND LID FROM THE STRUCTURE.
- C) COVER THE STRUCTURE OPENING WITH A 36 (900) DIAMETER METAL PLATE.
- D) BACKFILL WITH CRUSHED STONE AND A MINIMUM 1/2 (40) THICK HMA SURFACE MIX APPROVED BY THE ENGINEER.

STAGE 2 (AFTER PAVEMENT MILLING)

- A) REMOVE THE HMA SURFACE MIX AND CRUSHED STONE.
- B) INSTALL THE FRAME AND LID; ADJUST THE FRAME TO ITS FINAL SURFACE ELEVATION.
- C) THE SURROUNDING SPACE SHALL BE FILLED WITH CLASS PP-1* CONCRETE TO THE ELEVATION OF THE SURFACE OF THE EXISTING BASE COURSE OR THE BINDER COURSE.

* UNLESS OTHERWISE SPECIFIED IN THE PLANS.

THE PROCEDURE EXPLAINED ABOVE SHALL CONFORM TO THE APPLICABLE PORTIONS OF SECTIONS 353, 406, 602, AND 603 OF THE STANDARD SPECIFICATIONS EXCEPT THAT "THE CONTRACTOR SHALL ADJUST THE STRUCTURES TO THE FINISHED PAVEMENT ELEVATION NO MORE THAN 5 CALENDAR DAYS PRIOR TO PLACEMENT OF THE FINAL LIFT OF SURFACE UNLESS APPROVED BY THE ENGINEER."

LEGEND

- ① SUB-BASE GRANULAR MATERIAL
- ② EXISTING PAVEMENT
- ③ 36 (900) DIAMETER METAL PLATE
- ④ PROPOSED CRUSHED STONE AND HMA SURFACE MIX
- ⑤ EXISTING STRUCTURE
- ⑥ FRAME AND LID (SEE NOTES)
- ⑦ CLASS PP-1* CONCRETE
- ⑧ PROPOSED HMA SURFACE COURSE
- ⑨ PROPOSED HMA BINDER COURSE

LOCATION OF STRUCTURES:

THE CONTRACTOR WILL BE REQUIRED TO KEEP A RECORD OF THE LOCATIONS OF THE BURIED STRUCTURES ACCORDING TO THE STATION AND DISTANCE LEFT OR RIGHT OF THE CENTERLINE OF PAVEMENT. UPON COMPLETION OF THE WORK, THE CONTRACTOR WILL DELIVER THE RECORD TO THE ENGINEER.

BASIS OF PAYMENT:

REMOVING FRAMES AND LIDS ON DRAINAGE AND UTILITY STRUCTURES IN THE PAVEMENT PRIOR TO MILLING, AND ADJUSTING TO FINAL GRADE PRIOR TO PLACING THE SURFACE COURSE, WILL BE PAID FOR AT THE CONTRACT UNIT PRICE EACH FOR "FRAMES AND LIDS TO BE ADJUSTED (SPECIAL)."

THIS WORK WILL NOT BE PAID FOR WHEN DRAINAGE AND UTILITY STRUCTURES ARE SPECIFIED FOR PAYMENT AS STRUCTURE RECONSTRUCTION.

NEW FRAMES AND LIDS, WHEN SPECIFIED, WILL BE PAID FOR SEPARATELY.

NOTES:

EXISTING BROKEN FRAMES AND LIDS SHALL BE REMOVED AND DISPOSED OF BY THE CONTRACTOR AND SHALL BE REPLACED AS DIRECTED BY THE ENGINEER. REPLACEMENT FRAMES AND LIDS WILL BE PAID FOR IN ACCORDANCE WITH ARTICLE 109.04 OF THE STANDARD SPECIFICATIONS UNLESS A SEPARATE PAY ITEM HAS BEEN PROVIDED.

IF THE EXISTING LIDS ARE OPEN, THE FRAME WILL BE ADJUSTED TO THE ELEVATION OF THE MILLED PAVEMENT SURFACE PRIOR TO THE MILLING OPERATION. THE FRAME WILL NOT BE REMOVED AND COVERED BY THE METAL PLATE.

CITY OF CHICAGO CASTINGS ARE THE PROPERTY OF THE CITY AND THE CONTRACTOR SHALL NOTIFY THE CITY FOR REMOVAL AND DISPOSITION OF THE CASTINGS.

THE METAL PLATE USED TO COVER THE STRUCTURE SHALL REMAIN THE PROPERTY OF THE CONTRACTOR.

WHEN STRUCTURES ARE TO BE ADJUSTED OR RECONSTRUCTED, THE LOWERING AND RAISING OF THE FRAMES AND LIDS WILL NOT BE PAID FOR SEPARATELY BUT WILL BE INCLUDED IN THE COST OF THE CORRESPONDING PAY ITEM.

DETAILS FOR FRAMES AND LIDS ADJUSTMENT WITH MILLING

ALL DIMENSIONS ARE IN INCHES (MILLIMETERS) UNLESS OTHERWISE SHOWN

FILE NAME =	USER NAME = bauerdl	DESIGNED - R. SHAH	REVISED - R. WIEDEMAN 05-14-04
ct:\pw\work\p\dot\bauerdl\d0108315\bd08.dgn		DRAWN -	REVISED - R. BORO 01-01-07
	PLOT SCALE = 1/68.5000 "/ m	CHECKED -	REVISED - R. BORO 03-09-11
	PLOT DATE = 12/6/2011	DATE - 10-25-94	REVISED - R. BORO 12-06-11

**STATE OF ILLINOIS
DEPARTMENT OF TRANSPORTATION**

**DETAILS FOR
FRAMES AND LIDS ADJUSTMENT WITH MILLING**

SCALE: NONE SHEET NO. 1 OF 1 SHEETS STA. TO STA.

FAU. RTE.	SECTION	COUNTY	TOTAL SHEETS	SHEET NO.
0297	3178G-N(14)	COOK	151	111
BD600-03 (BD-8)		CONTRACT NO. 60Y26		
FED. ROAD DIST. NO. 1 ILLINOIS FED. AID PROJECT				

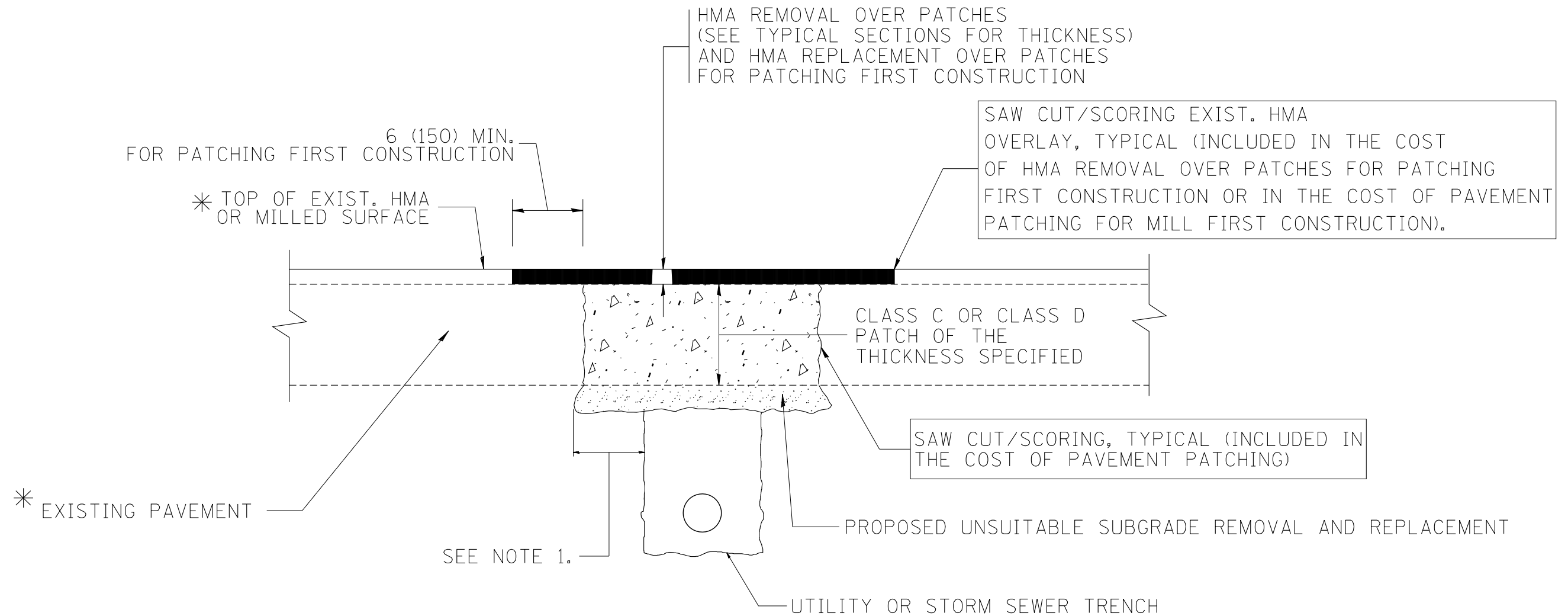

* SEE TYPICAL SECTIONS FOR THICKNESS AND MATERIALS

NOTES:

1. THE WIDTH OF THE FULL DEPTH PATCH OVER A TRENCH SHALL BE 12 (300) WIDER ON EACH SIDE OF THE TRENCH.
2. FOR METHOD OF MEASUREMENT AND BASIS OF PAYMENT, SEE RECURRING SPECIAL PROVISION "PATCHING WITH HOT-MIX ASPHALT OVERLAY REMOVAL".

SEQUENCE OF CONSTRUCTION (PATCHING FIRST)

1. REMOVE THE EXISTING HMA MATERIAL OVER THE AREA TO BE PATCHED.
2. REMOVE AND REPLACE WITH CLASS C OR D PATCH.
3. REPLACE HMA MATERIAL OVER THE AREA TO BE PATCHED.

SEQUENCE OF CONSTRUCTION (MILLING FIRST)

1. MILL HMA FIRST IF THERE IS AT LEAST 4 1/2 INCHES OR MORE OF HMA MATERIAL ON TOP OF THE EXISTING PAVEMENT OR IF THE PAVEMENT IS FULL DEPTH HMA. A MINIMUM OF 2 INCHES OF HMA MATERIAL SHALL BE IN PLACE AFTER MILLING.
2. REMOVE AND REPLACE WITH FULL DEPTH CLASS D PATCHES TO TOP OF MILLED SURFACE.

ALL DIMENSIONS ARE IN INCHES (MILLIMETERS) UNLESS OTHERWISE SHOWN.

FILE NAME = c:\projects\diststd22x34\bd22.dgn	USER NAME = bauerdl	DESIGNED - R. SHAH	REVISED - A. ABBAS 04-27-98
		DRAWN -	REVISED - R. BORO 01-01-07
		PLOT SCALE = 50.000' / IN.	REVISED - R. BORO 09-04-07
		PLOT DATE = 10/27/2008	REVISED - K. ENG 10-27-08

**STATE OF ILLINOIS
DEPARTMENT OF TRANSPORTATION**

PAVEMENT PATCHING FOR HMA SURFACED PAVEMENT	
SCALE: NONE	SHEET NO. 1 OF 1 SHEETS STA. TO STA.

FAU. RTE.	SECTION	COUNTY	TOTAL SHEETS	SHEET NO.
0297	3178G-N(14)	COOK	151	112
BD400-04 (BD-22)		CONTRACT NO. 60Y26		
FED. ROAD DIST. NO. 1 ILLINOIS FED. AID PROJECT				

VARIABLE - TO MEET EXISTING DIMENSIONS AND FIELD CONDITIONS (SEE NOTE ②)

PROP. CONC. CURB OR CURB AND GUTTER REPLACEMENT IN ACCORDANCE WITH STATE STANDARD 606001. (SEE NOTE ②)

SAW CUT FULL DEPTH - INCLUDED IN THE COST OF SIDEWALK, DRIVEWAY OR MEDIAN SURFACE REMOVAL PAY ITEM.

SEE STATE STANDARD 606001
EXISTING OR PROPOSED HMA SURFACE (IF APPLICABLE)

18" (450) MAX.

1/4" (5) **

EXISTING SIDEWALK, DRIVEWAY, MEDIAN SURFACE, SOD OR GROUND.

PROPOSED SIDEWALK, DRIVEWAY PAVEMENT, MEDIAN SURFACE OR SODDING SALT TOLERANT WITH TOP SOIL, 4" (100) SOD RESTORATION (SEE NOTE ①).

EXISTING CONCRETE PAVEMENT, CONCRETE BASE COURSE OR FLEXIBLE PAVEMENT

3" (75) MIN.

SUITABLE BACKFILL MATERIAL (INCLUDED IN THE COST OF CURB OR CURB AND GUTTER REMOVAL AND REPLACEMENT)

PROPOSED 3/4" (20) PREFORMED EXPANSION JOINT AT CONCRETE SIDEWALKS, DRIVEWAYS, AND MEDIANS. (INCLUDED IN THE COST OF CURB OR CURB AND GUTTER REMOVAL AND REPLACEMENT.)

* 3" (75) MINIMUM FROM TOP AND BOTTOM OF THE CONCRETE PAVEMENT OR BASE COURSE.

** IF THE FINAL SURFACE OF THE PAVEMENT IS CONCRETE, THE GUTTER IS TO BE FLUSH WITH THE PAVEMENT.

NOTE: ① SIDEWALK, DRIVEWAY PAVEMENT OR MEDIAN SURFACE SHALL BE SIMILAR TO THE MATERIAL BEING REMOVED AND WILL BE PAID FOR SEPARATELY.

SODDING, SALT TOLERANT AND TOP SOIL, FURNISH AND PLACE 4" WILL BE PAID FOR SEPARATELY,

② FERTILIZER FOR THE PLACEMENT OF THE SOD IS NOT REQUIRED

③ CURB OR CURB AND GUTTER REPLACEMENT SHALL MATCH THE SHAPE OF THE EXISTING CURB OR CURB AND GUTTER UNLESS OTHERWISE SPECIFIED.

④ FOR CURB OR CURB AND GUTTER REMOVAL AND REPLACEMENT ADJACENT TO FLEXIBLE PAVEMENT DELETE EPOXY COATED TIE BARS.

⑤ LONGITUDINAL BARS, IF ENCOUNTERED IN THE EXISTING CURB OR CURB AND GUTTER, ARE NOT TO BE REPLACED. CUTTING AND REMOVING LONGITUDINAL BARS SHALL BE INCLUDED IN THE COST OF CURB OR CURB AND GUTTER REMOVAL AND REPLACEMENT.

⑥ THE COST OF HMA SURFACE REMOVAL IN THE EXISTING GUTTER FLAG SHALL BE INCLUDED IN THE COST OF THE CURB AND GUTTER REMOVAL AND REPLACEMENT.

⑦ THE REMOVAL AND REPLACEMENT OF THE EXISTING CURB OR CURB AND GUTTER SHALL BE DONE IN ACCORDANCE WITH THE APPLICABLE PORTIONS OF SECTION 440 AND 606 OF THE STANDARD SPECIFICATIONS.

⑧ THE LOCATIONS OF REMOVAL AND REPLACEMENT OF EXISTING CURB OR CURB AND GUTTER SHALL BE DETERMINED BY THE RESIDENT ENGINEER AT THE TIME OF CONSTRUCTION.

UNSUITABLE SUB-BASE MATERIAL TO BE REMOVED, IF DIRECTED BY THE ENGINEER, SHALL BE REPLACED WITH EITHER SUB-BASE GRANULAR MATERIAL, TYPE B OR ADDITIONAL THICKNESS OF CONCRETE.

REMOVAL AND REPLACEMENT 4" (100) OR LESS IS INCLUDED IN THE COST OF CURB OR CURB AND GUTTER REMOVAL AND REPLACEMENT.

REMOVAL AND REPLACEMENT IN EXCESS OF 4" (100) WILL BE PAID FOR IN ACCORDANCE WITH ARTICLE 109.04 OF THE STANDARD SPECIFICATIONS.

PROPOSED #6 (20) EPOXY COATED TIE BARS 24" (600) LONG AT 24" (600) CENTERS WILL NOT BE PAID FOR SEPARATELY. DELETE EPOXY COATED TIE BARS IF EXISTING TIE BARS ARE USABLE AS DETERMINED BY THE ENGINEER. (SEE NOTE ③).

BASIS OF PAYMENT:
THIS WORK WILL BE PAID FOR AT THE CONTRACT UNIT PRICE PER FOOT (METER) FOR "CURB REMOVAL AND REPLACEMENT" OR "COMBINATION CONCRETE CURB AND GUTTER REMOVAL AND REPLACEMENT".

CURB OR CURB AND GUTTER REMOVAL AND REPLACEMENT

ALL DIMENSIONS ARE IN INCHES (MILLIMETERS) UNLESS OTHERWISE SHOWN.

FILE NAME =	USER NAME = drivakosgn	DESIGNED - A. HOUSEH	REVISED - R. SHAH 10-03-96	STATE OF ILLINOIS DEPARTMENT OF TRANSPORTATION	CURB OR CURB AND GUTTER REMOVAL AND REPLACEMENT	FAU	SECTION	COUNTY	TOTAL	SHEET
ct:\pw\work\p1dot\drivakosgn\0108315\bd24.dgn	DRAWN -	REVISED - A. ABBAS 03-21-97	0297			3178G-N(14)	COOK	151	113	
PLOT SCALE = 50.000' / IN.	CHECKED -	REVISED - M. GOMEZ 01-22-01	BD600-06 (BD-24)			CONTRACT NO. 60Y26				
PLOT DATE = 12/15/2009	DATE - 03-11-94	REVISED - R. BORO 12-15-09	SCALE: NONE			SHEET NO. 1 OF 1 SHEETS		STA. TO STA.		FED. ROAD DIST. NO. 1 ILLINOIS FED. AID PROJECT

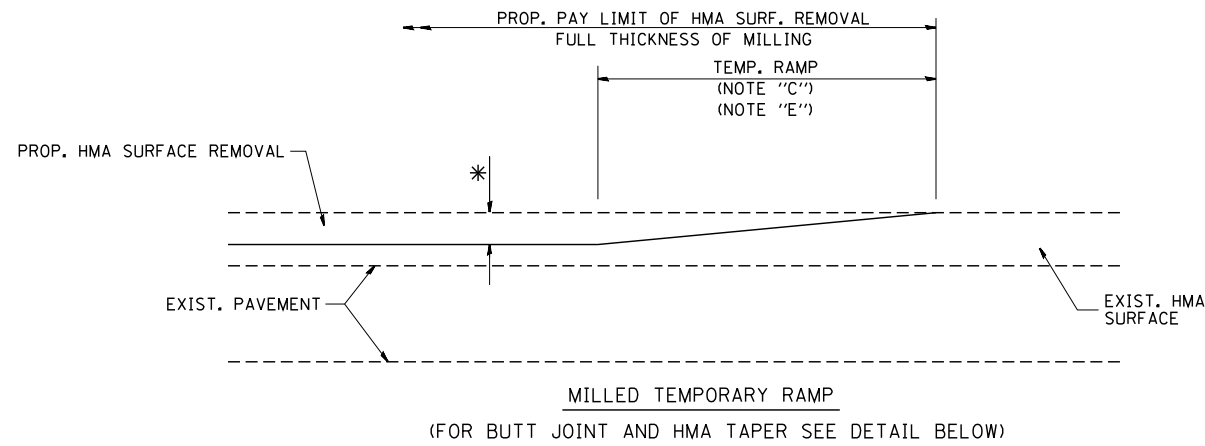

OPTION 1

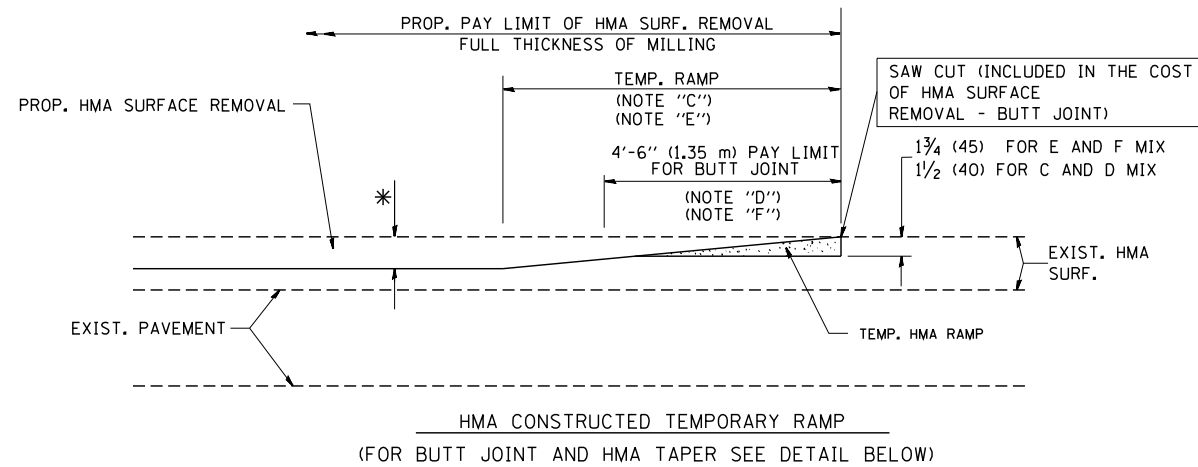

OPTION 2

TYPICAL TEMPORARY RAMP

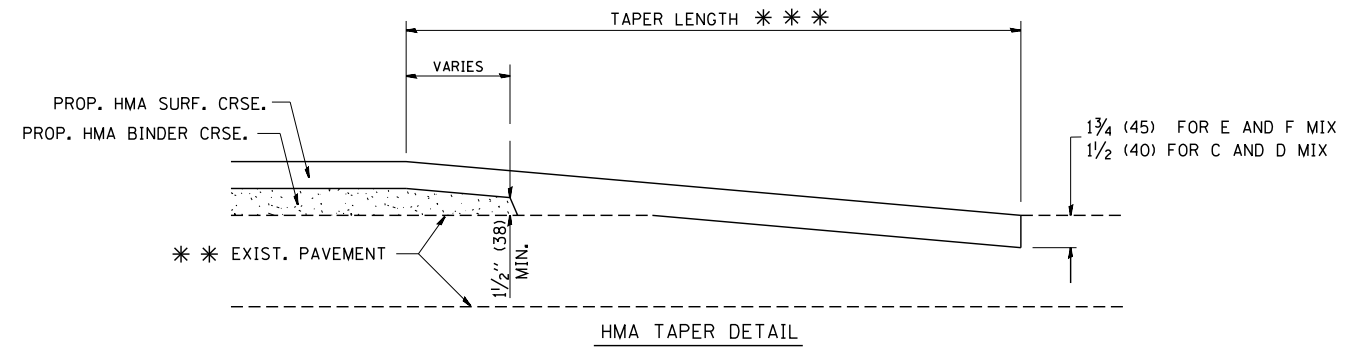
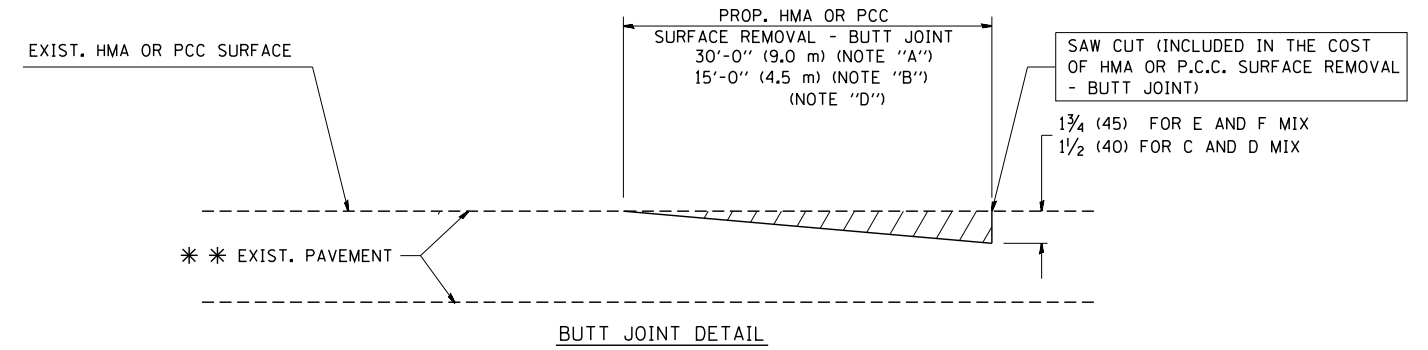

TYPICAL BUTT JOINT AND HMA TAPER FOR RESURFACING ONLY

*** PC CONCRETE, HMA OR HMA RESURFACED PAVEMENT.

NOTES

- A: MAINLINE ROADWAYS AND MAJOR SIDE ROADS.
 - B: MINOR SIDE ROADS.
 - C: THE TEMP. RAMP SHALL BE CONSTRUCTED IMMEDIATELY UPON REMOVAL OF THE EXISTING HMA SURFACE.
 - D: THE BUTT JOINT SHALL BE CONSTRUCTED IMMEDIATELY PRIOR TO PLACING THE PROPOSED HMA COURSES.
 - E: TAPER THE TEMP. RAMP AT A RATE OF 3'-0" (900 mm) PER 1 INCH (25 mm) OF MILLING THICKNESS.
 - F: INSTALLATION AND REMOVAL OF THE 4'-6" (1.35 m) TEMP. RAMP IS INCLUDED IN COST OF HMA SURFACE REMOVAL - BUTT JOINT
 - G: SEE ARTICLE 406.08 AND 406.14 OF THE STANDARD SPECIFICATIONS FOR "HMA AND/OR PCC SURFACE REMOVAL, BUTT JOINT".
- * SEE TYPICAL SECTIONS FOR MILLING THICKNESS.
- *** 20'-0" (6.1 m) PER 1 (25) RESURFACING (NOTE "A")
10'-0" (3.0 m) PER 1 (25) RESURFACING (NOTE "B")

BASIS OF PAYMENT:

THE BUTT JOINT WILL BE PAID FOR AT THE CONTRACT UNIT PRICE PER SQUARE YARD (SQUARE METER) FOR "HOT-MIX ASPHALT SURFACE REMOVAL - BUTT JOINT" OR FOR "PORTLAND CEMENT CONCRETE SURFACE REMOVAL - BUTT JOINT".

ALL DIMENSIONS ARE IN INCHES (MILLIMETERS) UNLESS OTHERWISE SHOWN.

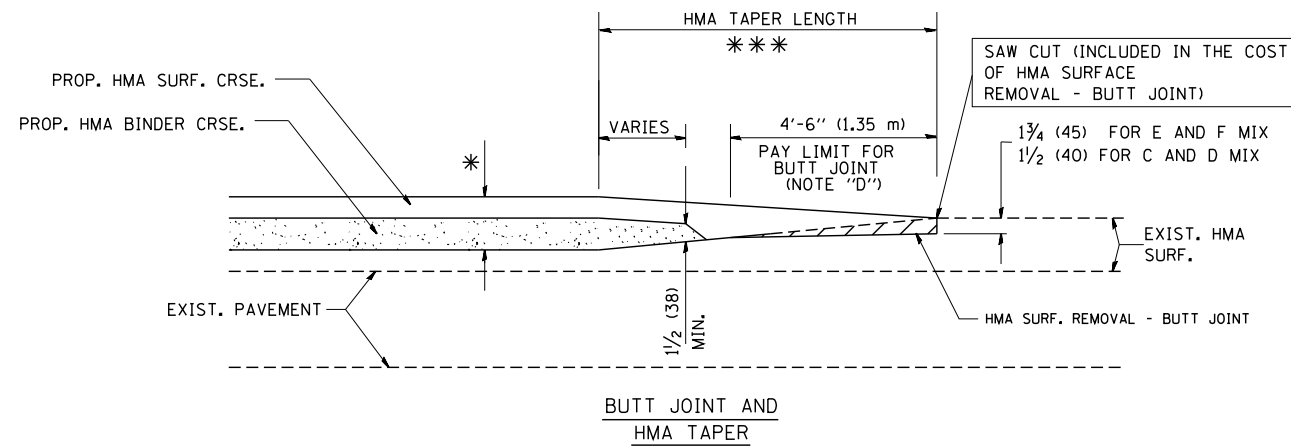

TYPICAL BUTT JOINT AND HMA TAPER FOR MILLING AND RESURFACING

FILE NAME = W:\diststd\22x34\bd32.dgn	USER NAME = geglionobt	DESIGNED - M. DE YONG	REVISED - R. SHAH 10-25-94
		DRAWN -	REVISED - A. ABBAS 03-21-97
	PLOT SCALE = 50.0000' / IN.	CHECKED -	REVISED - M. GOMEZ 04-06-01
	PLOT DATE = 1/4/2008	DATE - 06-13-90	REVISED - R. BORO 01-01-07

**STATE OF ILLINOIS
DEPARTMENT OF TRANSPORTATION**

BUTT JOINT AND HMA TAPER DETAILS	
SCALE: NONE	SHEET NO. 1 OF 1 SHEETS
STA.	TO STA.

FAU. RTE.	SECTION	COUNTY	TOTAL SHEETS	SHEET NO.
0297	3178G-N(14)	COOK	151	114
BD400-05 BD32		CONTRACT NO. 60Y26		
FED. ROAD DIST. NO. 1 ILLINOIS FED. AID PROJECT				

GENERAL NOTES

ALTERNATE MATERIAL FOR THE WALLS MAY BE CONCRETE MASONRY UNITS, PRECAST REINFORCED CONCRETE SECTIONS OR CAST-IN-PLACE CONCRETE. THE CAST IRON STEPS AS DETAILED HEREON ARE TYPICAL. STEPS OF OTHER DESIGN AND MATERIAL THAT CONFORM TO THE MINIMUM REQUIREMENTS OF THE STEPS SHOWN MAY BE USED WHEN APPROVED BY THE ENGINEER.

CAST IRON STEPS SHALL BE GRAY IRON CONFORMING TO THE REQUIREMENTS OF ARTICLE 1006.14 OF THE STANDARD SPECIFICATIONS.

STEPS SHALL BE EMBEDDED INTO THE WALL A MINIMUM OF THREE (3) INCHES. STEPS SHALL NOT BE EXTENDED ON THE OUTSIDE.

STEPS SHALL BE OMITTED FOR WORK IN COOK COUNTY WHEN THE DEPTH OF THE MANHOLE IS TEN (10') OR LESS.

IN ADDITION TO THE REQUIREMENTS OF ARTICLE 612.13 OF THE STANDARD SPECIFICATIONS, THE CONTRACT UNIT PRICE FOR MANHOLES, TYPE A, 7'-DIAMETER SHALL INCLUDE THE SAND CUSHION WHEN REQUIRED, FURNISHING AND INSTALLING STEPS WHEN REQUIRED, FURNISHING AND COMPACTING THE SPECIFIED BACKFILL MATERIAL, AND FURNISHING AND INSTALLING FLAT SLAB TOP.

PRECAST FLAT SLAB TOP SHALL CONFORM TO ARTICLES 505.01 THRU 505.05 OF THE STANDARD SPECIFICATIONS EXCEPT THAT THE CONCRETE STRENGTH SHALL BE 4,000 PSI AFTER 28 DAYS. REINFORCEMENT BARS AND WELDED WIRE FABRIC SHALL CONFORM TO THE REQUIREMENTS OF ARTICLE 1006.10. ONLY GRADE 60 REINFORCEMENT BARS WILL BE PERMITTED.

BOTTOM SLAB SHALL BE REINFORCED BY EITHER REINFORCEMENT BARS OR WELDED WIRE FABRIC. THE MINIMUM REINFORCEMENT SHALL BE 0.46 SQUARE INCH PER LINEAR FOOT IN BOTH DIRECTIONS.

JOINT CONFIGURATION AND DIMENSIONS OF FLAT SLAB TOP SHALL MATCH AND FIT THE RISER JOINT DETAIL.

LIFTING DEVICES SHALL BE APPROVED BY THE ENGINEER.

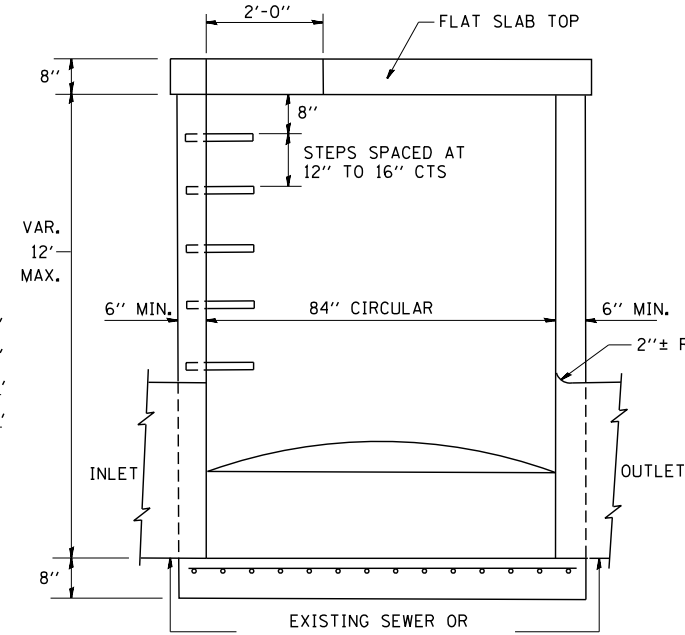

ELEVATION

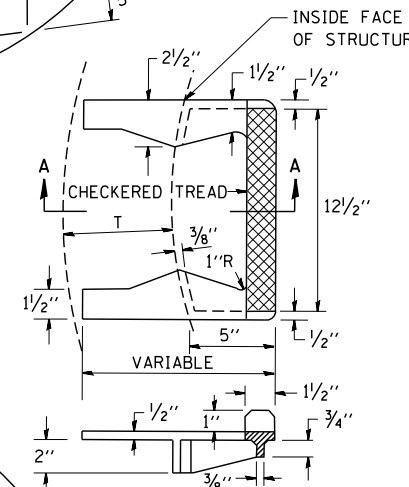

**SEC. A-A
CAST IRON STEPS**

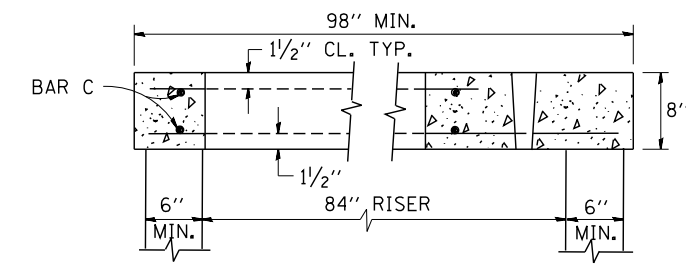

SECTION B-B

ALTERNATE MATERIALS FOR RISERS	T (MIN.)
CONCRETE MASONRY UNITS	5"
PRECAST REINFORCED CONCRETE SECTIONS	4"
CAST-IN-PLACE CONCRETE	6"

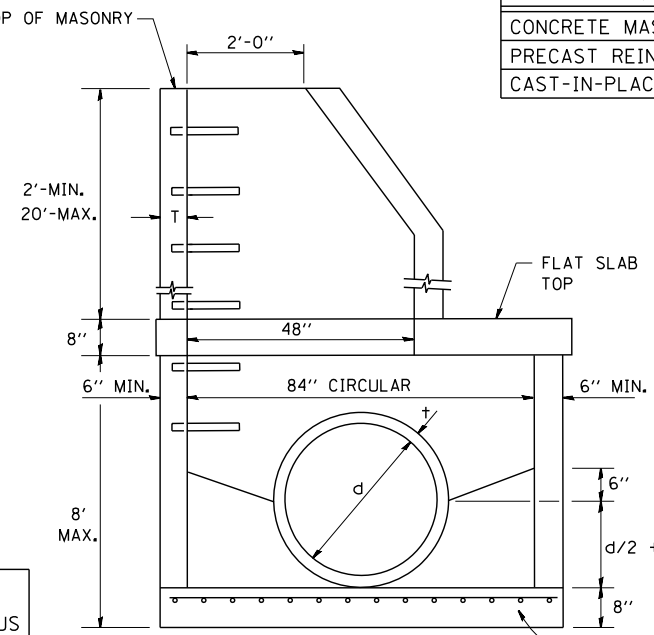

ELEVATION

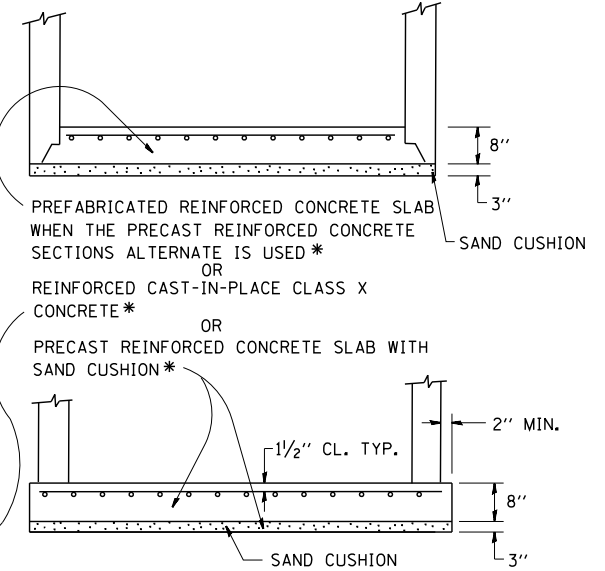

PREFABRICATED REINFORCED CONCRETE SLAB WHEN THE PRECAST REINFORCED CONCRETE SECTIONS ALTERNATE IS USED *

OR REINFORCED CAST-IN-PLACE CLASS X CONCRETE *

OR PRECAST REINFORCED CONCRETE SLAB WITH SAND CUSHION *

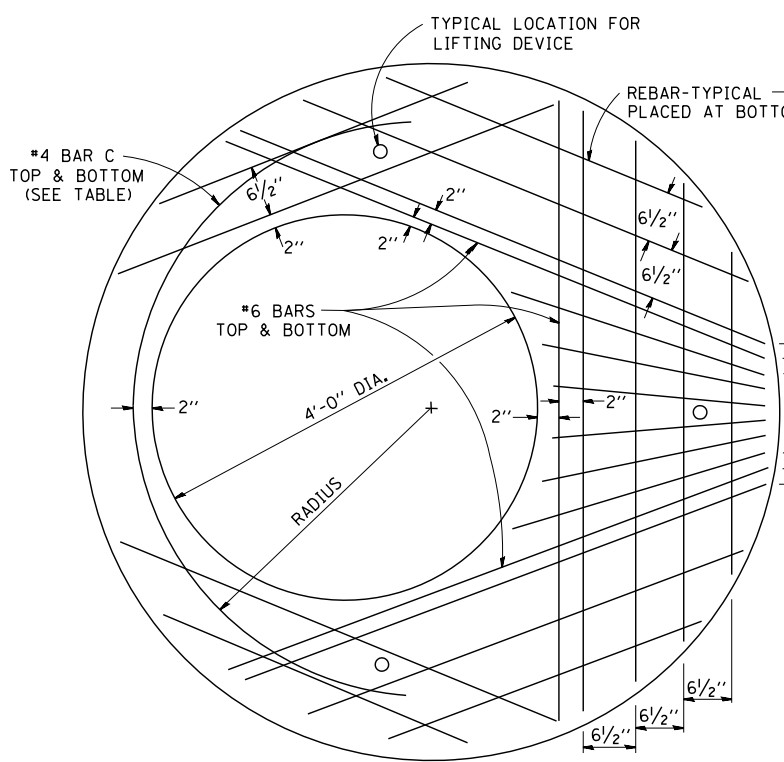

PLAN

SHOWING REBAR REINFORCEMENT

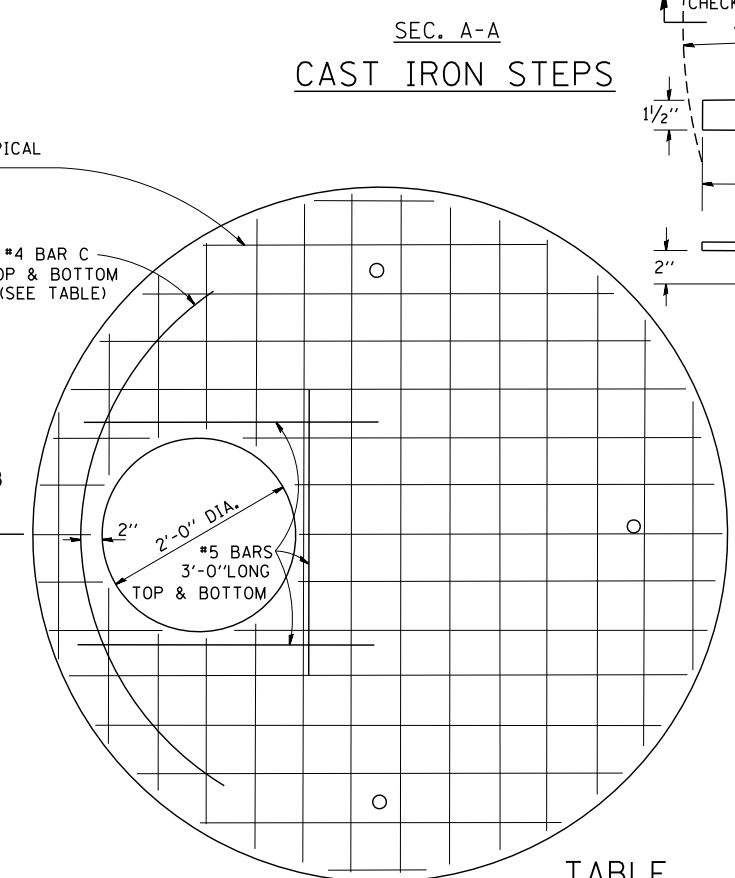

TABLE

DIAMETER OF OPENING	REINFORCEMENT "A _c " WWF OR SIZE EACH DIRECTION	BAR SIZE	BAR C		
			SIZE	LENGTH	RADIUS
2'-0"	1.06 SQ.IN./LIN.FT.	#6	#4	6'-0"	38"
4'-0"	0.82 SQ.IN./LIN.FT.	#6	#4	9'-0"	38"

PLAN

SHOWING WELDED WIRE FABRIC REINFORCEMENT

NOTE: THIS STRUCTURE SHOULD BE USED WITH PIPES SIZE 54" DIA. OR SMALLER.

FILE NAME = W:\diststd\22x34\bd37.dgn

USER NAME = gaglionobt
PLOT SCALE = 50.0000' / IN.
PLOT DATE = 1/4/2008

DESIGNED -
DRAWN -
CHECKED -
DATE - 10-18-02

REVISED -
REVISED -
REVISED -
REVISED -

**STATE OF ILLINOIS
DEPARTMENT OF TRANSPORTATION**

**MANHOLE TYPE A
7 FOOT DIAMETER**

SCALE: NONE SHEET NO. 1 OF 1 SHEETS STA. TO STA.

F.A.U. RTE.	SECTION	COUNTY	TOTAL SHEETS	SHEET NO.
0297	3178G-N(14)	COOK	151	115
BD600-11 (BD-37)		CONTRACT NO. 60Y26		
FED. ROAD DIST. NO. 1 ILLINOIS FED. AID PROJECT				

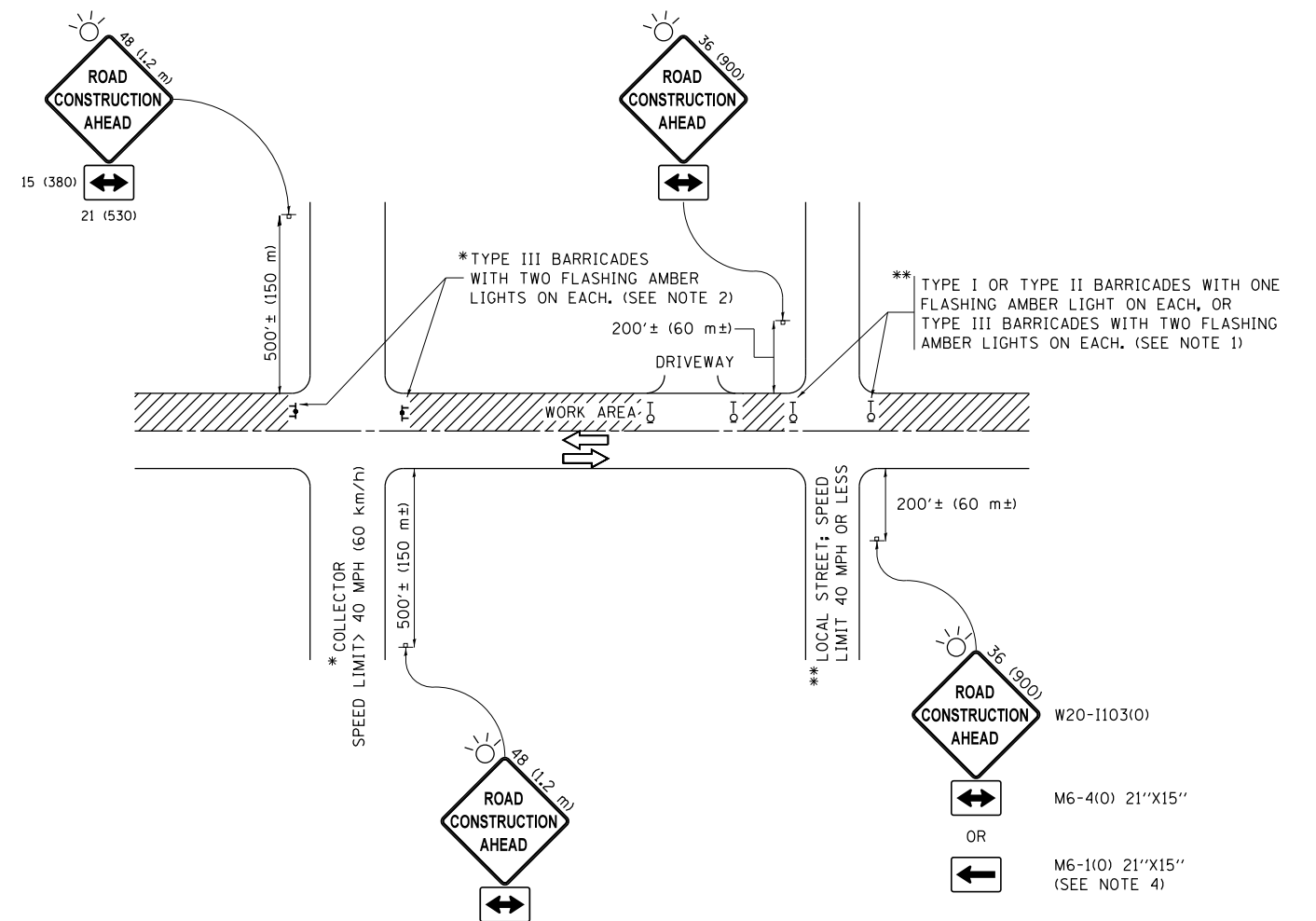

NOTES:

1. SIDE ROAD WITH A SPEED LIMIT OF 40 MPH (60 km/h) OR LESS AND AS DIRECTED BY THE ENGINEER:
 - a) ONE "ROAD CONSTRUCTION AHEAD" SIGN 36 x 36 (900x900) WITH A FLASHER MOUNTED ON IT APPROXIMATELY 200' (60 m) IN ADVANCE OF THE MAIN ROUTE.
 - b) THE CLOSED PORTION OF THE MAIN ROUTE SHALL BE PROTECTED BY BLOCKING WITH TYPE I, TYPE II OR TYPE III BARRICADES, 1/3 OF THE CROSS SECTION OF THE CLOSED PORTION.
2. SIDE ROAD WITH A SPEED LIMIT GREATER THAN 40 MPH (60 km/h) AS SHOWN ON THE DRAWING AND AS DIRECTED BY THE ENGINEER:
 - a) ONE "ROAD CONSTRUCTION AHEAD" SIGN 48 x 48 (1.2 m x 1.2 m) WITH A FLASHER MOUNTED ON IT APPROXIMATELY 500' (150 m) IN ADVANCE OF THE MAIN ROUTE.
 - b) THE CLOSED PORTION OF THE MAIN ROUTE SHALL BE PROTECTED BY BLOCKING WITH TYPE III BARRICADES, 1/2 OF THE CROSS SECTION OF THE CLOSED PORTION.
3. CONES MAY BE SUBSTITUTED FOR BARRICADES OR DRUMS AT HALF THE SPACING DURING DAY OPERATIONS. CONES SHALL BE A MINIMUM OF 28 (710) IN HEIGHT.
4. WHEN THE SIDE ROAD LIES BETWEEN THE BEGINNING OF THE MAINLINE SIGNING AND THE WORK ZONE, A SINGLE HEADED ARROW (M6-1) SHALL BE USED IN LIEU OF THE DOUBLE HEADED ARROW (M6-4).
5. WHEN WORK IS BEING PERFORMED ON A SIDE ROAD OR DRIVEWAY, FOLLOW THE APPLICABLE STANDARD(S). THE DIRECTIONAL ARROW (M6-1 OR M6-4) SHALL BE COVERED OR REMOVED WHEN NO LONGER CONSISTENT WITH THE TRAFFIC CONTROL SET-UP.
6. ADVANCE WARNING SIGNS ARE TO BE OMITTED ON DRIVEWAYS UNLESS OTHERWISE SPECIFIED IN THE PLANS OR BY THE ENGINEER.
7. THE TRAFFIC CONTROL AND PROTECTION FOR SIDE ROADS, INTERSECTIONS, AND DRIVEWAYS SHALL BE INCLUDED IN THE COST OF SPECIFIED TRAFFIC CONTROL STANDARDS OR ITEMS.

All dimensions are in inches (millimeters) unless otherwise shown.

FILE NAME =	USER NAME = footemj	DESIGNED - L.H.A.	REVISED - A. HOUSEH 10-15-96
p:\11084EBIDINTEG\illinois.gov\PWIDOT\Documents\IDOT Offices\District 1\Projects\Dist 1\11084EBIDINTEG\CADD\to\CAD\sheets\tc10.dgn			REVISED - T. RAMMACHER 01-06-00
Default	PLOT SCALE = 50.000' / in.	CHECKED -	REVISED - A. SCHUETZE 07-01-13
	PLOT DATE = 9/15/2016	DATE - 06-89	REVISED - A. SCHUETZE 09-15-16

**STATE OF ILLINOIS
DEPARTMENT OF TRANSPORTATION**

**TRAFFIC CONTROL AND PROTECTION FOR
SIDE ROADS, INTERSECTIONS, AND DRIVEWAYS**

SCALE: NONE SHEET 1 OF 1 SHEETS STA. TO STA.

F.A.U. RTE.	SECTION	COUNTY	TOTAL SHEETS	SHEET NO.
0297	3178G-N(14)	COOK	151	116
TC-10		CONTRACT NO. 60Y26		
ILLINOIS FED. AID PROJECT				

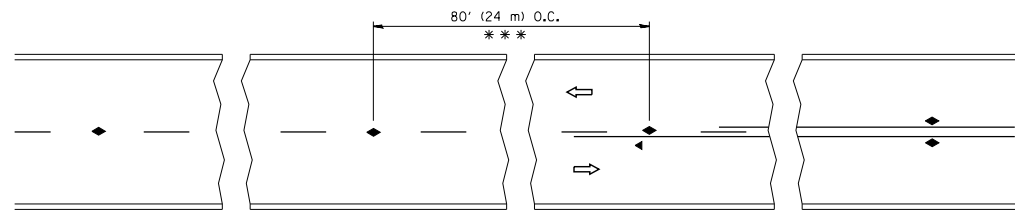

*** REDUCE TO 40' (12 m) O.C. ON CURVES WITH POSTED OR ADVISORY SPEED 45 M.P.H. (70 km/h) OR LESS.

TWO-LANE/TWO-WAY

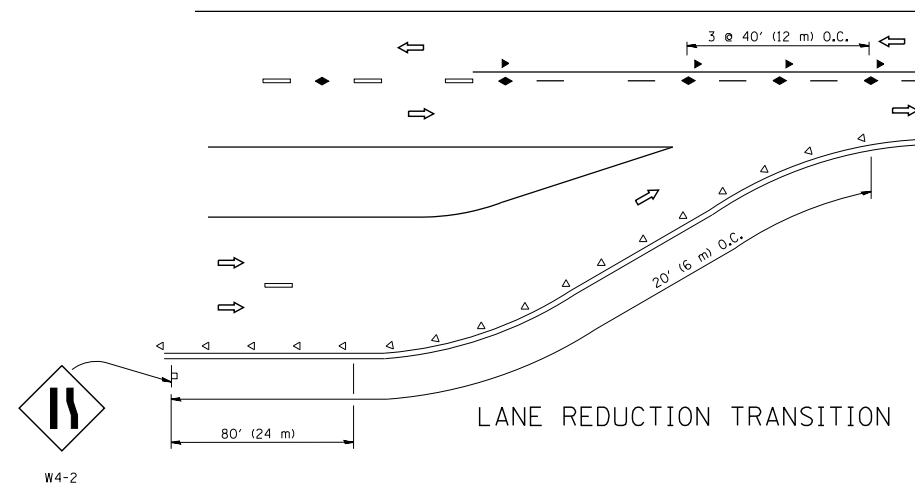

LANE REDUCTION TRANSITION

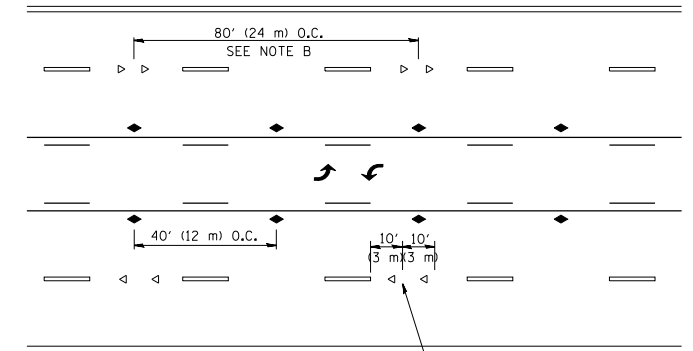

TWO-WAY LEFT TURN

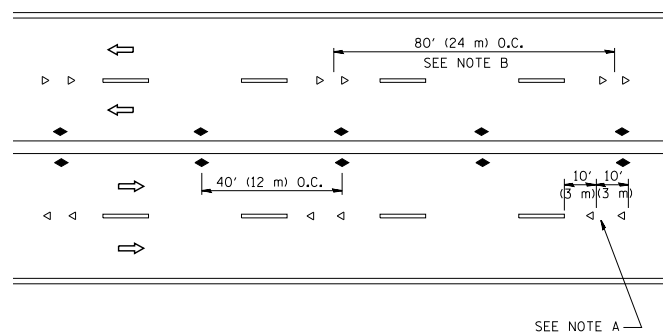

MULTI-LANE/UNDIVIDED

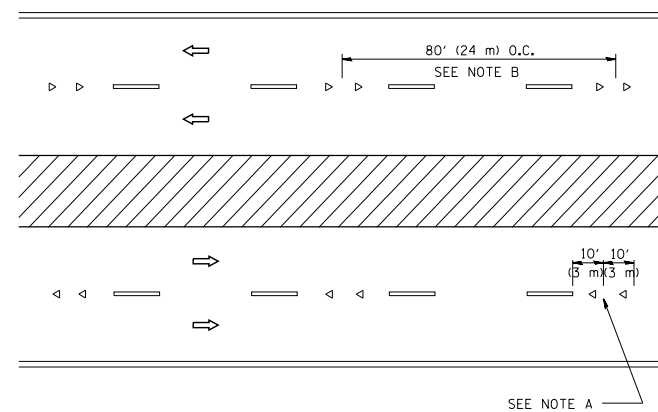

MULTI-LANE/DIVIDED

GENERAL NOTES

1. MARKERS USED WITH DASHED LINES SHALL BE CENTERED IN THE GAP BETWEEN SEGMENTS.
2. MARKERS USED ADJACENT TO SOLID LINES SHALL BE OFFSET 2 TO 3 (50 TO 75) TOWARD TRAFFIC AS SHOWN.
3. MARKERS THROUGH TANGENTS LESS THAN 500' (150 m) IN LENGTH BETWEEN CURVES SHALL BE INSTALLED AT THE LESSER OF THE TWO CURVE SPACINGS.

SYMBOLS

- YELLOW STRIPE
- WHITE STRIPE
- ◀ ONE-WAY AMBER MARKER
- ◁ ONE-WAY CRYSTAL MARKER (W/O)
- ◆ TWO-WAY AMBER MARKER

LANE MARKER NOTES

- A. USE DOUBLE LANE LINE MARKERS SPACED AS SHOWN.
- B. REDUCE TO 40' (12 m) O.C. ON CURVES WHERE ADVISORY SPEEDS ARE 10 M.P.H (20 km/h) LOWER THAN POSTED SPEEDS.

DESIGN NOTES

1. DOUBLE LANE LINE MARKERS SHALL BE USED UNLESS SPECIFIED OTHERWISE.
2. EXCEPT AS SHOWN ON THE LANE REDUCTION TRANSITION AND FREEWAY EXIT RAMP DETAIL, MARKERS ARE NOT TO BE SPECIFIED ON RIGHT EDGE LINES.
3. THE EXACT MARKER LIMITS, SPACING, AND COLOR SHALL BE INCLUDED IN THE PLANS WHEN STANDARD SPECIFICATIONS ARE NOT BEING USED.
4. MARKERS SHOULD NOT BE USED ALONGSIDE CURBS EXCEPT FOR EXTREMELY SHORT SECTIONS OF CURBS WHERE NOT MORE THAN TWO MARKERS WOULD BE INVOLVED.

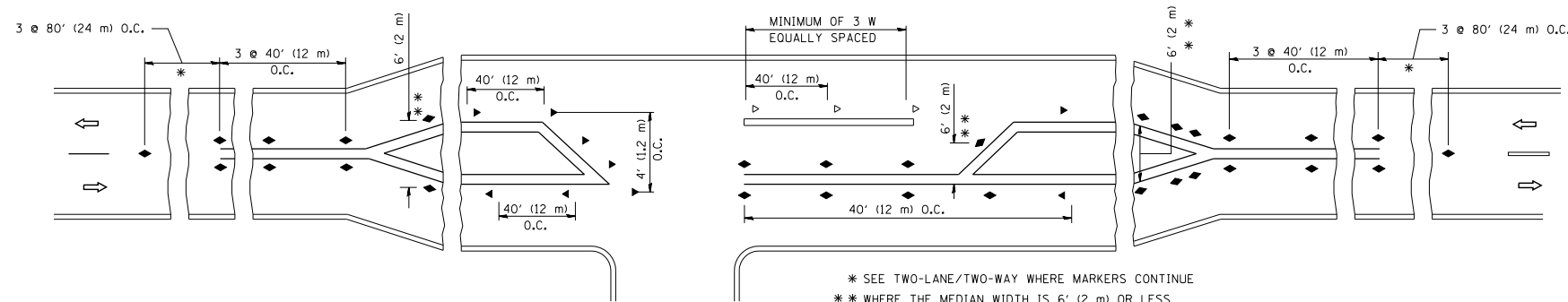

LEFT TURN

All dimensions are in inches (millimeters) unless otherwise shown.

FILE NAME =	USER NAME = l1eysa	DESIGNED -	REVISED - T. RAMMACHER 09-19-94
ct:\pw\work\p1dot\1eysa\d0108315\tc11.dgn		DRAWN -	REVISED - T. RAMMACHER 03-12-99
		CHECKED -	REVISED - T. RAMMACHER 01-06-00
		DATE -	REVISED - C. JUCIUS 09-09-09

STATE OF ILLINOIS
DEPARTMENT OF TRANSPORTATION

TYPICAL APPLICATIONS
RAISED REFLECTIVE PAVEMENT MARKERS (SNOW-PLOW RESISTANT)

SCALE: NONE SHEET NO. 1 OF 1 SHEETS STA. TO STA.

FAU. RTE.	SECTION	COUNTY	TOTAL SHEETS	SHEET NO.
0297	3178G-N(14)	COOK	151	117
TC-11		CONTRACT NO. 60Y26		
FED. ROAD DIST. NO. 1 ILLINOIS FED. AID PROJECT				

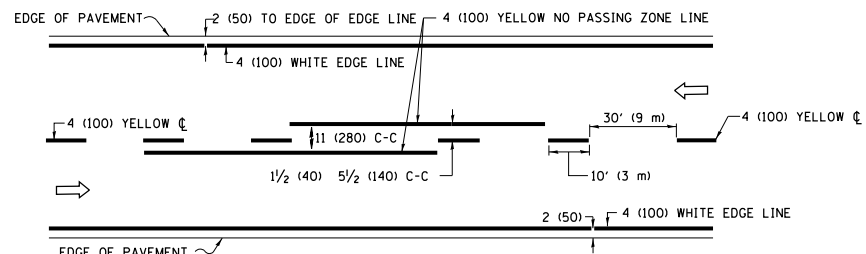

2-LANE ROADWAY

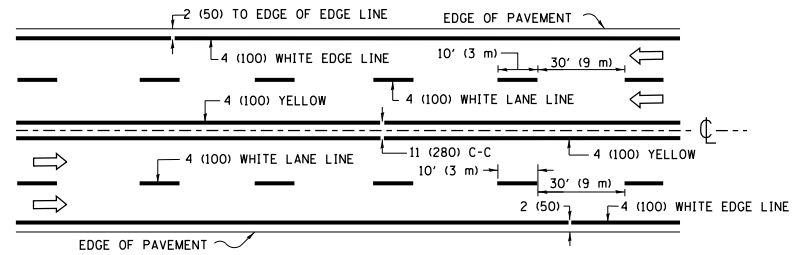

MULTI-LANE UNDIVIDED

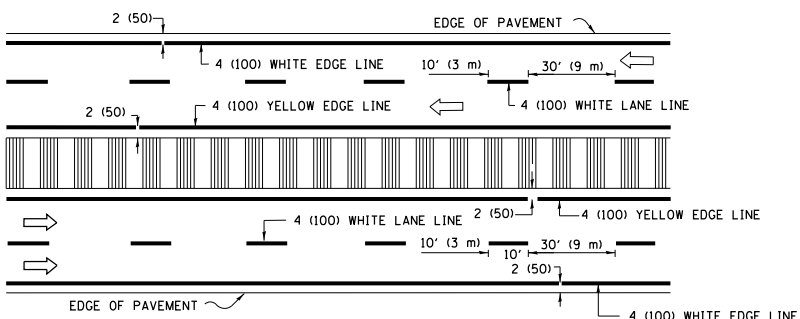

MULTI-LANE DIVIDED WITH MEDIAN

TYPICAL LANE AND EDGE LINE MARKING

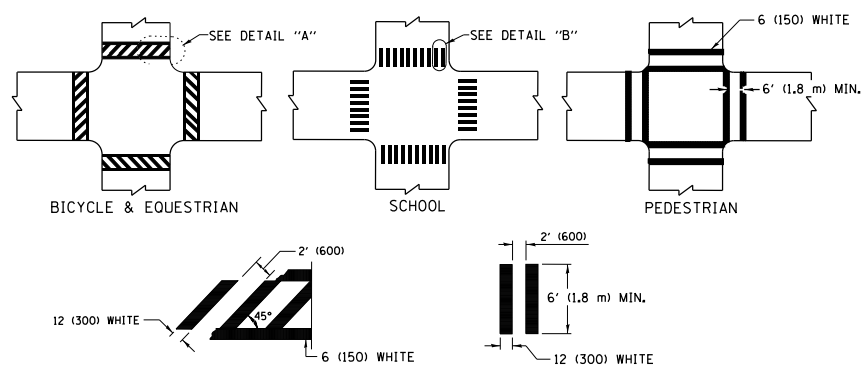

TYPICAL CROSSWALK MARKING

* MARKINGS SHALL BE INSTALLED PARALLEL TO THE CENTERLINE OF THE ROAD WHICH IT CROSSES

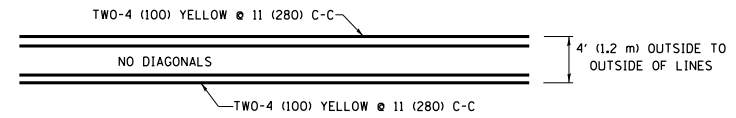

4' (1.2 m) WIDE MEDIANS ONLY

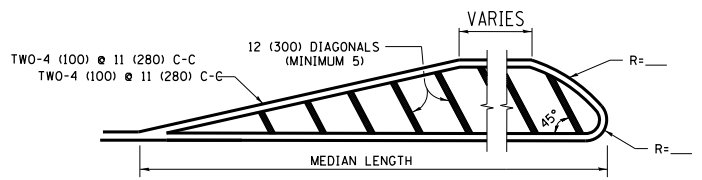

MEDIANS OVER 4' (1.2 m) WIDE

DIAGONAL LINE SPACING: 50' (15 m) C-C (LESS THAN 30MPH (50 km/h))
75' (25 m) C-C 30MPH (50 km/h) TO 45MPH (70 km/h)
150' (45 m) C-C (MORE THAN 45MPH (70 km/h))

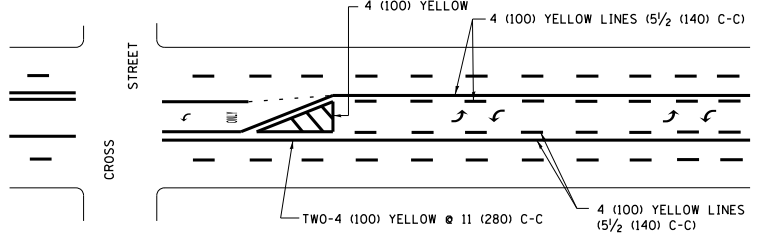

MEDIAN WITH TWO-WAY LEFT TURN LANE TYPICAL PAINTED MEDIAN MARKING

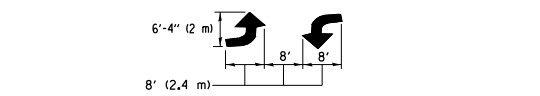

TYPICAL LEFT (OR RIGHT) TURN LANE

TYPICAL TURN LANE MARKING

FULL SIZE LETTERS 8' (2.4 m) AND ARROWS SHALL BE USED.
AREA = 15.6 SQ. FT. (1.5 m²) ONLY AREA = 20.8 SQ. FT. (1.9 m²)
* TURN LANES IN EXCESS OF 400' (120 m) IN LENGTH MAY HAVE AN ADDITIONAL SET OF ARROW - "ONLY" INSTALLED MIDWAY BETWEEN THE OTHER TWO SETS OF ARROW - "ONLY".

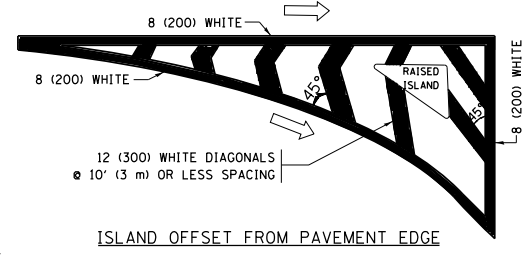

ISLAND OFFSET FROM PAVEMENT EDGE

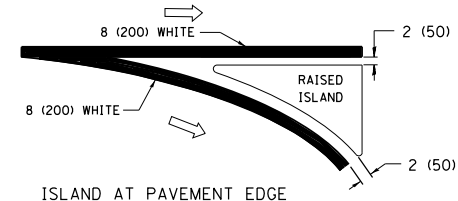

ISLAND AT PAVEMENT EDGE

TYPICAL ISLAND MARKING

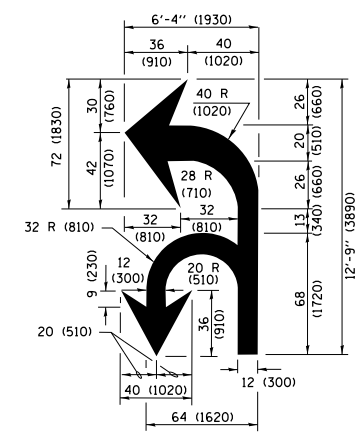

COMBINATION LEFT AND U-TURN

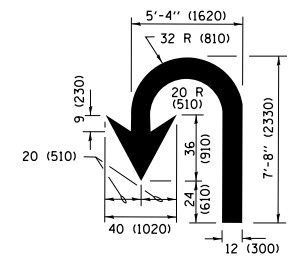

U-TURN

LANE REDUCTION TRANSITION

* LANE REDUCTION ARROWS REQUIRED AT SPEEDS OF 45 MPH OR GREATER OR WHEN SPECIFIED IN PLANS.

D(FT)	SPEED LIMIT
345	30
425	35
500	40
580	45
665	50
750	55

TYPE OF MARKING	WIDTH OF LINE	PATTERN	COLOR	SPACING /REMARKS
CENTERLINE ON 2 LANE PAVEMENT	4 (100)	SKIP-DASH	YELLOW	10' (3 m) LINE WITH 30' (9 m) SPACE
CENTERLINE ON MULTI-LANE UNDIVIDED PAVEMENT	2 @ 4 (100)	SOLID	YELLOW	11 (280) C-C
NO PASSING ZONE LINES FOR ONE DIRECTION FOR BOTH DIRECTIONS	4 (100) 2 @ 4 (100)	SOLID SOLID	YELLOW YELLOW	5/2 (140) C-C FROM SKIP-DASH CENTERLINE 11 (280) C-C OMIT SKIP-DASH CENTERLINE BETWEEN
LANE LINES	4 (100) 5 (125) ON FREEWAYS	SKIP-DASH SKIP-DASH	WHITE WHITE	10' (3 m) LINE WITH 30' (9 m) SPACE
DOTTED LINES (EXTENSIONS OF CENTER, LANE OR TURN LANE MARKINGS)	SAME AS LINE BEING EXTENDED	SKIP-DASH	SAME AS LINE BEING EXTENDED	2' (600) LINE WITH 6' (1.8 m) SPACE
EDGE LINES	4 (100)	SOLID	YELLOW-LEFT WHITE-RIGHT	OUTLINE MEDIANS IN YELLOW
TURN LANE MARKINGS	6 (150) LINE; FULL SIZE LETTERS & SYMBOLS (8' (2.4m))	SOLID	WHITE	SEE TYPICAL TURN LANE MARKING DETAIL
TWO WAY LEFT TURN MARKING	2 @ 4 (100) EACH DIRECTION 8' (2.4m) LEFT ARROW	SKIP-DASH AND SOLID IN PAIRS	YELLOW WHITE	10' (3 m) LINE WITH 30' (9 m) SPACE FOR SKIP-DASH; 5/2 (140) C-C BETWEEN SOLID LINE AND SKIP-DASH LINE SEE TYPICAL TWO-WAY LEFT TURN MARKING DETAIL
CROSSWALK LINES (PEDESTRIAN) A. DIAGONALS (BIKE & EQUESTRIAN) B. LONGITUDINAL BARS (SCHOOL)	2 @ 6 (150) 12 (300) @ 45° 12 (300) @ 90°	SOLID SOLID SOLID	WHITE WHITE WHITE	NOT LESS THAN 6' (1.8 m) APART 2' (600) APART 2' (600) APART SEE TYPICAL CROSSWALK MARKING DETAILS.
STOP LINES	24 (600)	SOLID	WHITE	PLACE 4' (1.2 m) IN ADVANCE OF AND PARALLEL TO CROSSWALK, IF PRESENT, OTHERWISE, PLACE AT DESIRED STOPPING POINT, PARALLEL TO CROSSROAD CENTERLINE, WHERE POSSIBLE
PAINTED MEDIANS	2 @ 4 (100) WITH 12 (300) DIAGONALS @ 45° NO DIAGONALS USED FOR 4' (1.2 m) WIDE MEDIANS	SOLID	YELLOW; TWO WAY TRAFFIC WHITE; ONE WAY TRAFFIC	11 (280) C-C FOR THE DOUBLE LINE SEE TYPICAL PAINTED MEDIAN MARKING.
GORE MARKING AND CHANNELIZING LINES	8 (200) WITH 12 (300) DIAGONALS @ 45°	SOLID	WHITE	DIAGONALS: 15' (4.5 m) C-C (LESS THAN 30MPH (50 km/h)) 20' (6 m) C-C 30MPH (50 km/h) TO 45MPH (70 km/h) 30' (9 m) C-C (OVER 45MPH (70 km/h))
RAILROAD CROSSING	24 (600) TRANSVERSE LINES; "RR" IS 6' (1.8 m) LETTERS; 16 (400) LINE FOR "X"	SOLID	WHITE	SEE STATE STANDARD 780001 AREA OF: "R"=3.6 SQ. FT. (0.33 m ²) EACH "X"=54.0 SQ. FT. (5.0 m ²)
SHOULDER DIAGONALS (REQUIRED FOR SHOULDERS ≥ 8')	12 (300) @ 45°	SOLID	WHITE - RIGHT YELLOW - LEFT	50' (15 m) C-C (LESS THAN 30MPH (50 km/h)) 75' (25 m) C-C (30 MPH (50 km/h) TO 45MPH (70 km/h)) 150' (45 m) C-C (OVER 45MPH (70 km/h))
U TURN ARROW	SEE DETAIL	SOLID	WHITE	16.3 SF
2 ARROW COMBINATION LEFT AND U TURN	SEE DETAIL	SOLID	WHITE	30.4 SF

FOR FURTHER DETAILS ON PAVEMENT MARKING REFER TO STANDARD SPECIFICATIONS FOR ROAD AND BRIDGE CONSTRUCTION AND STATE STANDARD 780001.

All dimensions are in inches (millimeters) unless otherwise shown.

FILE NAME = W:\diststd\22x34\to13.dgn	USER NAME = l1950	DESIGNED - EVERS	REVISED - C. JUCIUS 09-09-09
Default	PLOT SCALE = 50.000' / in.	DRAWN -	REVISED - C. JUCIUS 07-01-13
	PLOT DATE = 6/23/2017	CHECKED -	REVISED - C. JUCIUS 12-21-15
		DATE - 03-19-90	REVISED - C. JUCIUS 04-12-16

**STATE OF ILLINOIS
DEPARTMENT OF TRANSPORTATION**

**DISTRICT ONE
TYPICAL PAVEMENT MARKINGS**

SCALE: NONE	SHEET 1	OF 1	SHEETS	STA.	TO STA.
-------------	---------	------	--------	------	---------

F.A.U. RTE.	SECTION	COUNTY	TOTAL SHEETS	SHEET NO.
0297	3178G-N(14)	COOK	151	118
TC-13		CONTRACT NO. 60Y26		
ILLINOIS FED. AID PROJECT				

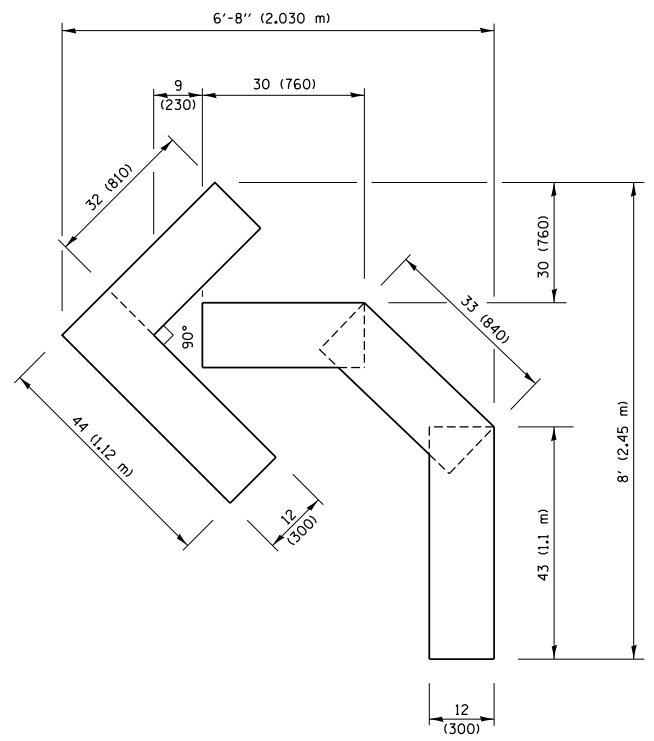

QUANTITY
 4 (100) LINE = 45.5 ft. (13.9 m)
 15.2 sq. ft. (1.41 sq. m)

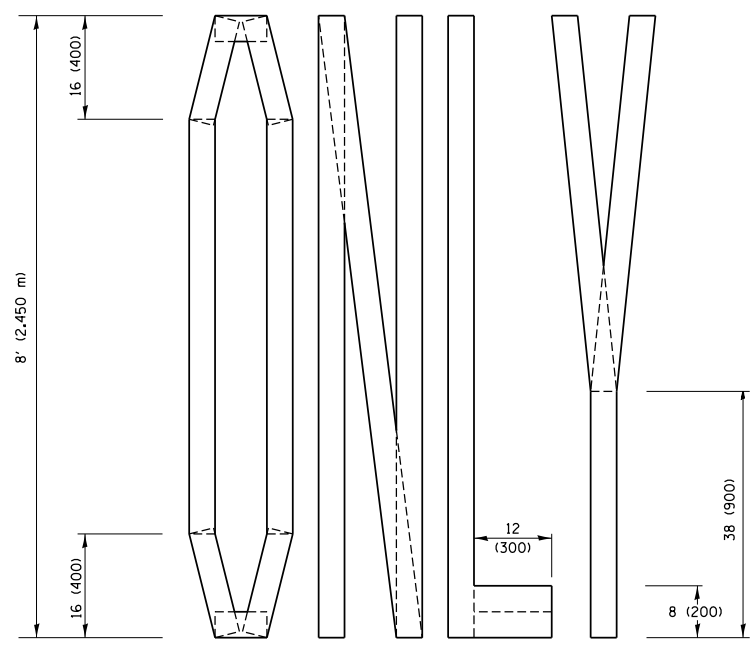
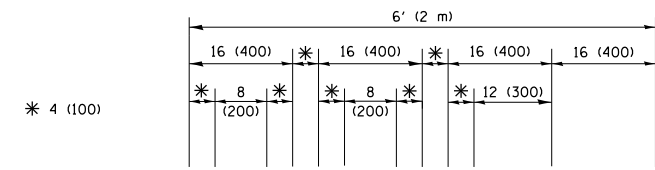

QUANTITY
 4 (100) LINE = 64.1 ft. (19.5 m)
 21.4 sq. ft. (1.99 sq. m)

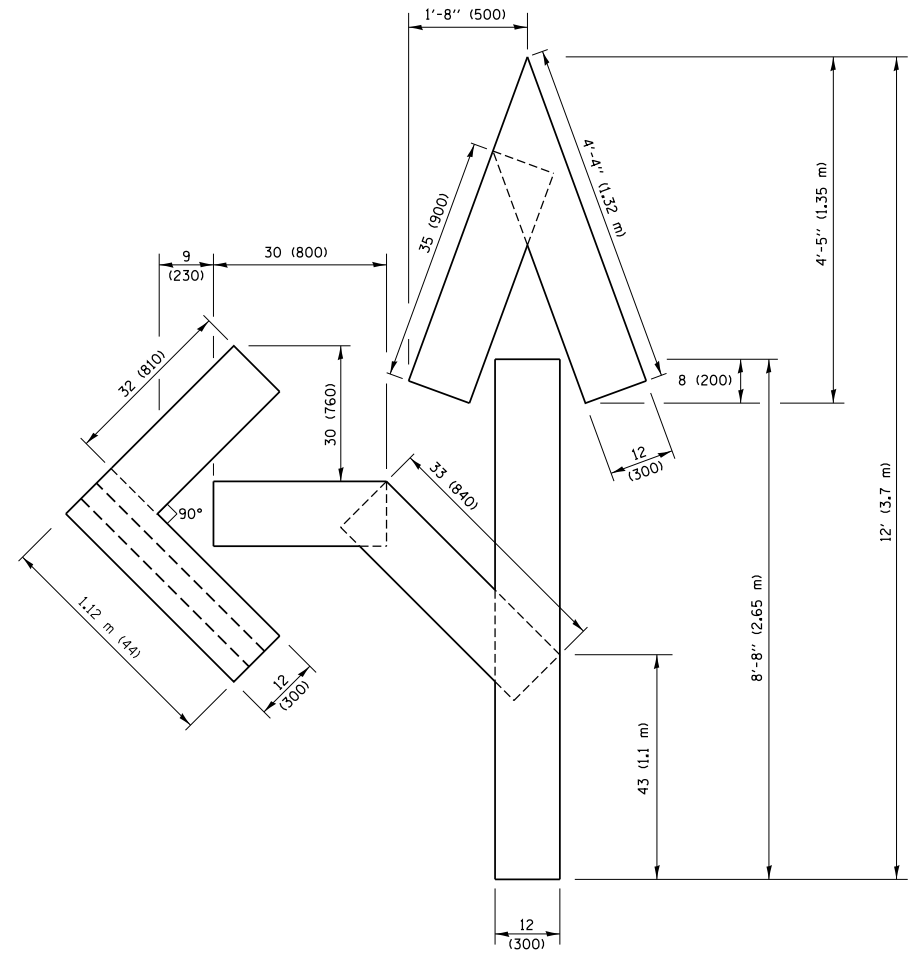

QUANTITY
 4 (100) LINE = 82.5 ft. (25.1 m)
 27.5 sq. ft. (2.53 sq. m)

NOTE:
 ALL QUANTITIES OF PLACEMENT ARE REPRESENTED IN LINEAR FEET OF 4" LINES TO MATCH THE 4" TEMPORARY TAPE PAY ITEM AND REPRESENTS THE TOTAL QUANTITY OF 4" TAPE REQUIRED.

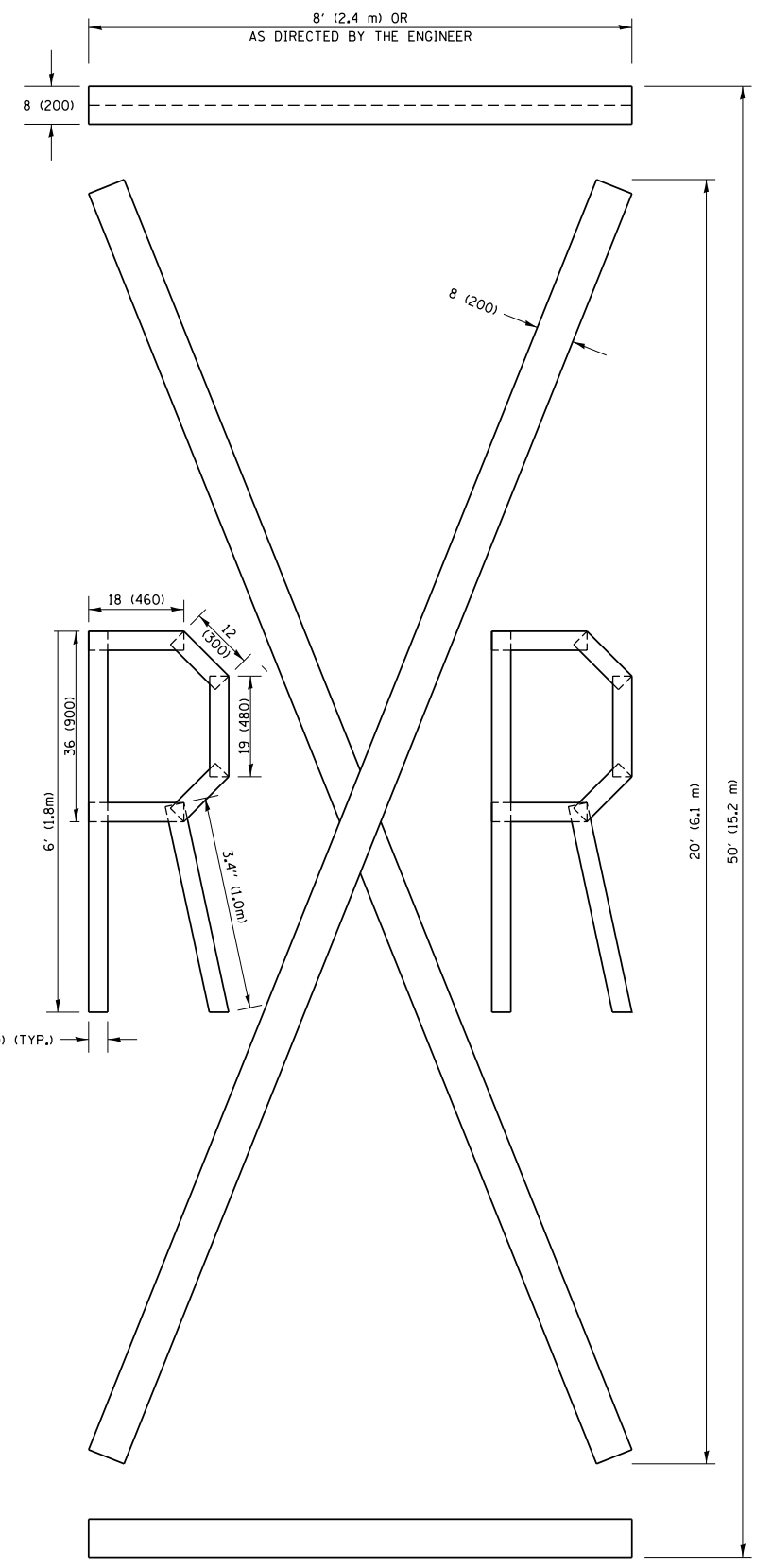

QUANTITY
 4 (100) LINE = 225.9 ft. (68.9 m)
 75.3 sq. ft. (6.99 sq. m)

All dimensions are in inches (millimeters) unless otherwise shown.

FILE NAME =	USER NAME = footemj	DESIGNED -	REVISED - T. RAMMACHER 03-02-98
p:\1\084EBIDINTEG.111inois.gov\PIWIDOT\Documents\IDOT Offices\District 1\Projects\Dist 1\084EBIDINTEG\CADData\CADsheets\tc16.dgn		CHECKED -	REVISED - E. GOMEZ 08-28-00
		DATE -	REVISED - E. GOMEZ 08-28-00
			REVISED - A. SCHUETZE 09-15-16

**STATE OF ILLINOIS
 DEPARTMENT OF TRANSPORTATION**

SHORT TERM PAVEMENT MARKING LETTERS AND SYMBOLS			
SCALE: NONE	SHEET NO. 1 OF 1 SHEETS	STA.	TO STA.

F.A.U. RTE.	SECTION	COUNTY	TOTAL SHEETS	SHEET NO.
0297	3178G-N(14)	COOK	151	119
TC-16		CONTRACT NO. 60Y26		
FED. ROAD DIST. NO. 1 ILLINOIS FED. AID PROJECT				

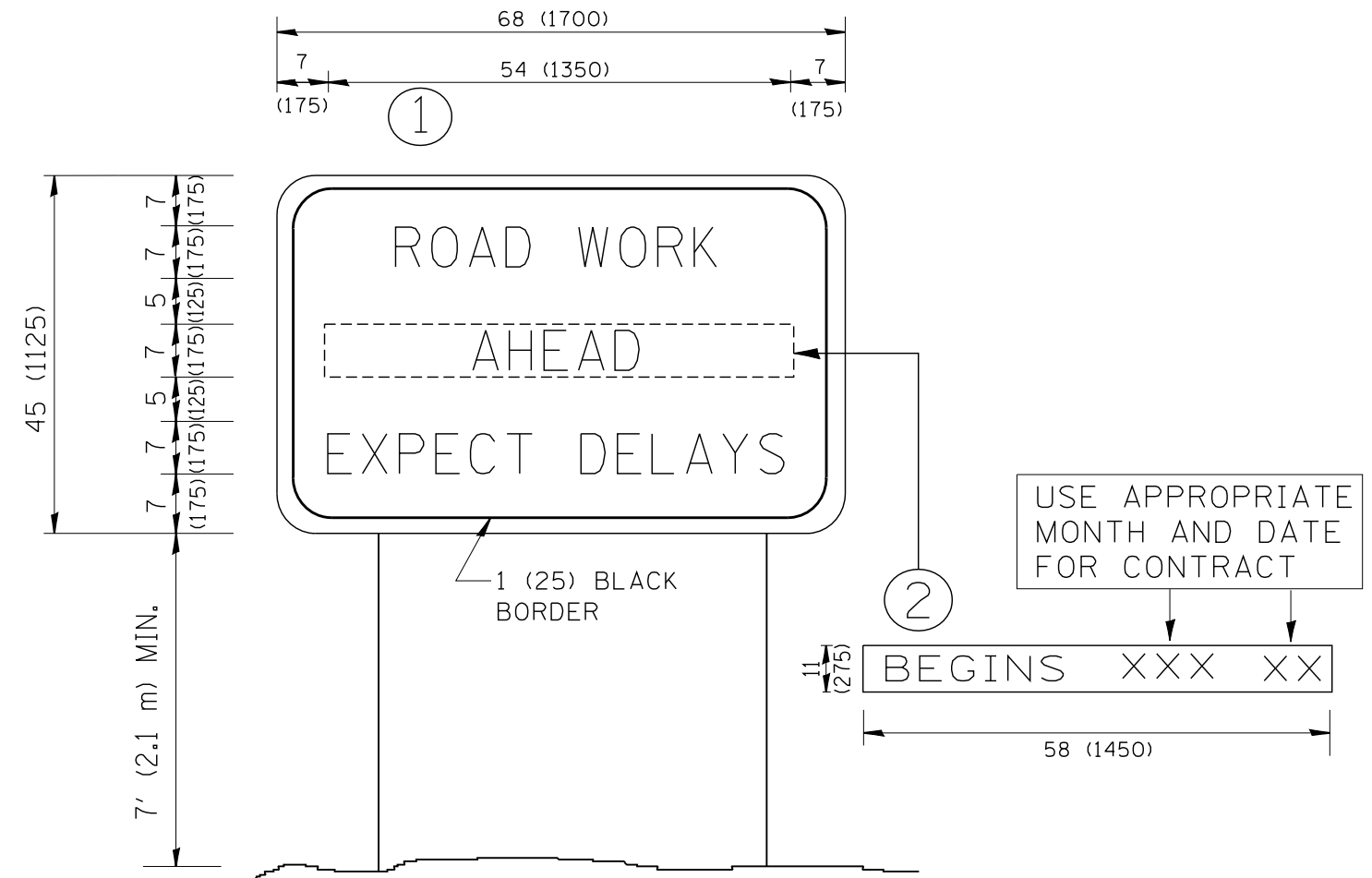

NOTES:

1. USE BLACK LETTERING ON ORANGE BACKGROUND.
2. ERECT SIGNS IN ADVANCE OF THE LOCATION FOR THE "ROAD CONSTRUCTION AHEAD" SIGN AT LOCATIONS AS DIRECTED BY THE ENGINEER.
3. ERECT SIGN ① WITH INSTALLED PANEL ② ONE WEEK PRIOR TO THE START OF CONSTRUCTION.
4. REMOVE PANEL ② SOON AFTER THE START OF CONSTRUCTION.
5. SEE SPECIAL PROVISION FOR "TEMPORARY INFORMATION SIGNING" FOR ADDITIONAL INFORMATION.
6. ONE SIGN ASSEMBLY EQUALS 25.70 SQ. FT. (2.3 SQ. M.)
7. SHALL BE PAID FOR AS TEMPORARY INFORMATION SIGNING.

ALL DIMENSIONS ARE IN INCHES (MILLIMETERS) UNLESS OTHERWISE SHOWN.

FILE NAME = W:\diststd\22x34\tc22.dgn	USER NAME = gegl@nbt	DESIGNED -	REVISED - R. MIRS 09-15-97
		DRAWN -	REVISED - R. MIRS 12-11-97
	PLOT SCALE = 50.000' / IN.	CHECKED -	REVISED - T. RAMMACHER 02-02-99
	PLOT DATE = 1/4/2008	DATE -	REVISED - C. JUCIUS 01-31-07

**STATE OF ILLINOIS
DEPARTMENT OF TRANSPORTATION**

**ARTERIAL ROAD
INFORMATION SIGN**

SCALE: NONE SHEET NO. 1 OF 1 SHEETS STA. TO STA.

FAU. RTE.	SECTION	COUNTY	TOTAL SHEETS	SHEET NO.
0297	3178G-N(14)	COOK	151	120
TC-22		CONTRACT NO. 60Y26		
FED. ROAD DIST. NO. 1 ILLINOIS FED. AID PROJECT				

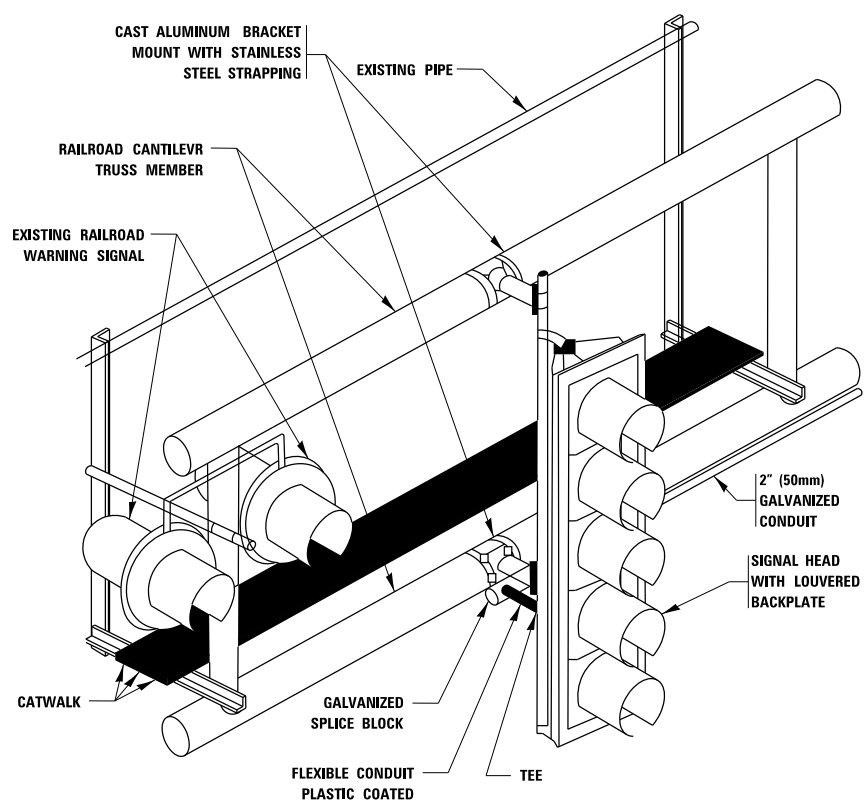

RAILROAD CANTILEVER SIGNAL HEAD MOUNTING
 USE NON-CONDUCTIVE SPACERS BETWEEN THE TRAFFIC SIGNAL EQUIPMENT AND THE RAILROAD CANTILEVER TO PREVENT DISSIMILAR METAL CORROSION
 N.T.S.

SIGNING AND PAVEMENT MARKING AT RAILROAD CROSSINGS

SIGNING AND PAVEMENT MARKING TRAFFIC CONTROL STANDARD (TC-23) HAS BEEN DEVELOPED IN CONSULTATION WITH THE ILLINOIS COMMERCE COMMISSION AND THE U.S. DEPARTMENT OF TRANSPORTATION'S GRADE CROSSING SAFETY TASK FORCE. THIS STANDARD PROVIDES INFORMATION ON UPDATES TO THE PAVEMENT MARKING AND SIGNING DETAILS IN ORDER TO INCORPORATE CHANGES ADOPTED IN THE 2009 NATIONAL MANUAL ON UNIFORM TRAFFIC CONTROL DEVICE (MUTCD). THESE NEW DETAILS HAVE BEEN STUDIED AND TESTED BY THE DEPARTMENT AND ACCEPTED BY THE ILLINOIS COMMERCE COMMISSION.

THIS APPLIES TO PROJECTS WHICH INCLUDE RAILROAD INTERCONNECTED TRAFFIC SIGNALS, WITH OR WITHOUT PRE-SIGNALS. THIS STANDARD ALSO APPLIES TO NON-SIGNALIZED INTERSECTIONS THAT ARE WITHIN 81 FEET OF A RAILROAD GRADE CROSSING. THE ILLINOIS SUPPLEMENT TO THE MUTCD SHOULD BE CONSULTED FOR ADDITIONAL INFORMATION ON SIGN REQUIREMENTS AT NON-SIGNALIZED INTERSECTIONS NEAR RAILROAD GRADE CROSSINGS.

THESE DETAILS WILL BE INCLUDED IN A FUTURE UPDATE TO THE BUREAU OF OPERATIONS TRAFFIC POLICIES AND PROCEDURES MANUAL.

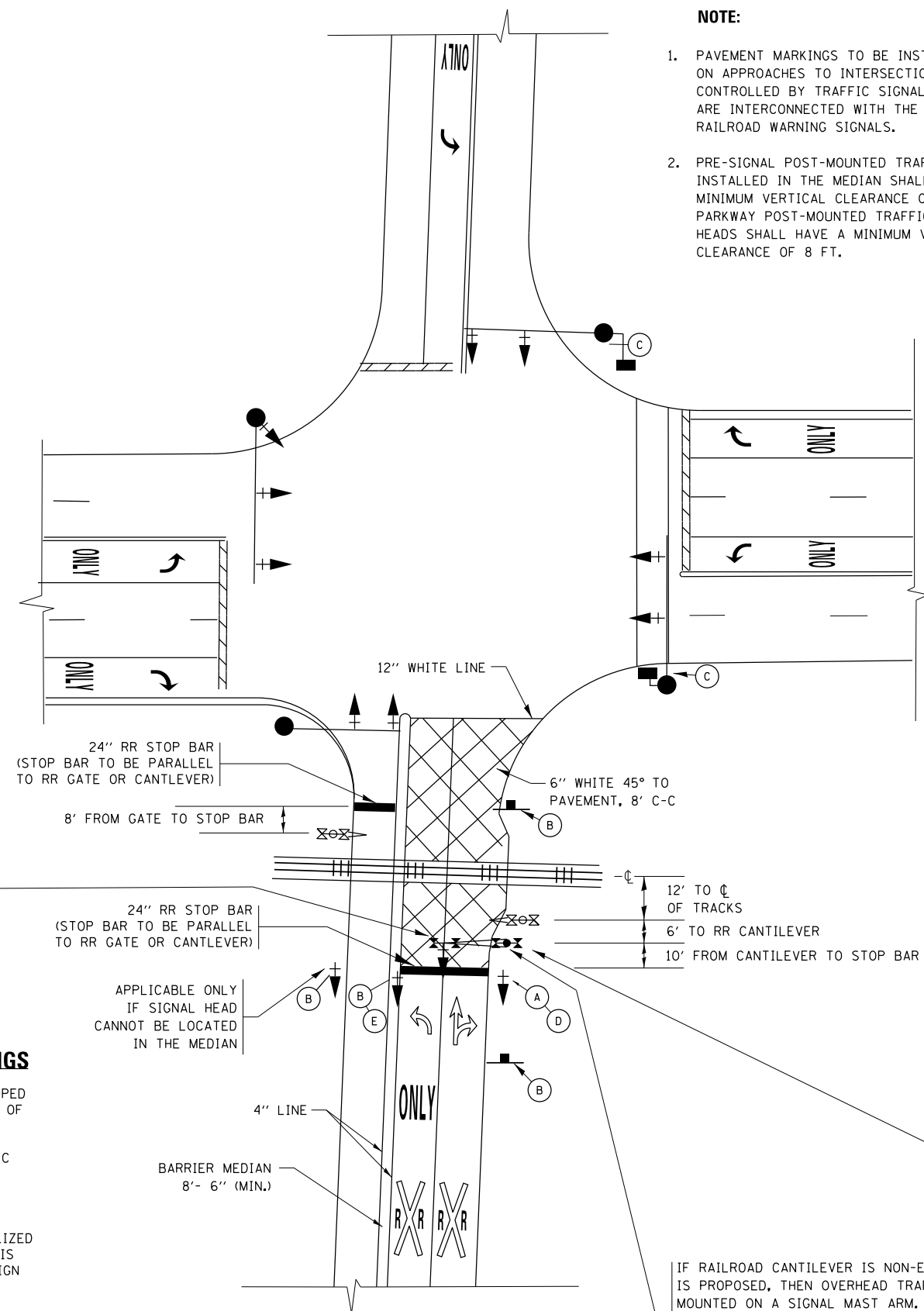

SIGNALIZED INTERSECTION WITH NEAR-SIDE TRAFFIC SIGNAL

- NOTE:**
- PAVEMENT MARKINGS TO BE INSTALLED ONLY ON APPROACHES TO INTERSECTIONS CONTROLLED BY TRAFFIC SIGNALS WHICH ARE INTERCONNECTED WITH THE RAILROAD WARNING SIGNALS.
 - PRE-SIGNAL POST-MOUNTED TRAFFIC SIGNAL HEADS INSTALLED IN THE MEDIAN SHALL HAVE A MINIMUM VERTICAL CLEARANCE OF 4.5 FT. PARKWAY POST-MOUNTED TRAFFIC SIGNAL HEADS SHALL HAVE A MINIMUM VERTICAL CLEARANCE OF 8 FT.

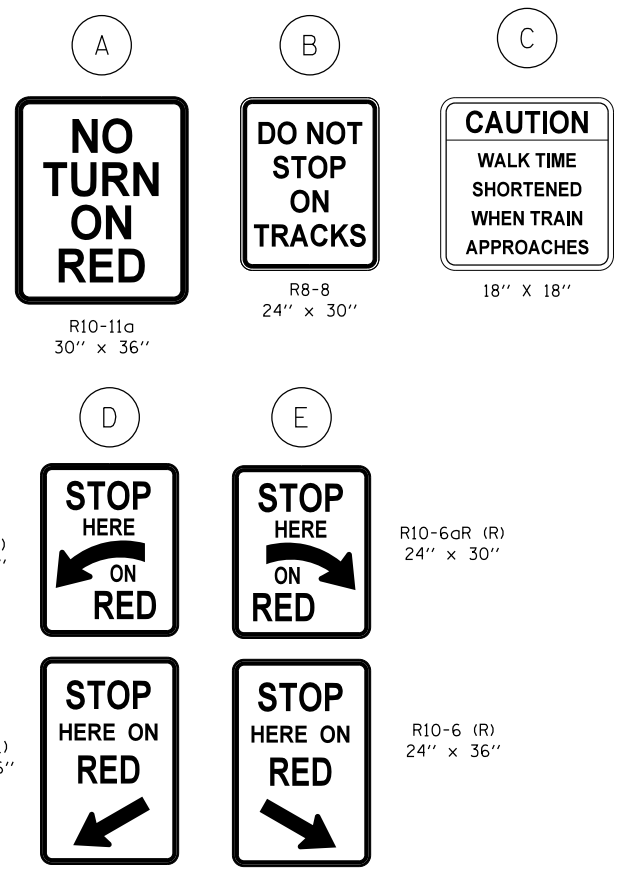

R10-11a
30" x 36"

R8-8
24" x 30"

R10-6a (L)
24" x 30"

R10-6aR (R)
24" x 30"

R10-6 (L)
24" x 36"

R10-6 (R)
24" x 36"

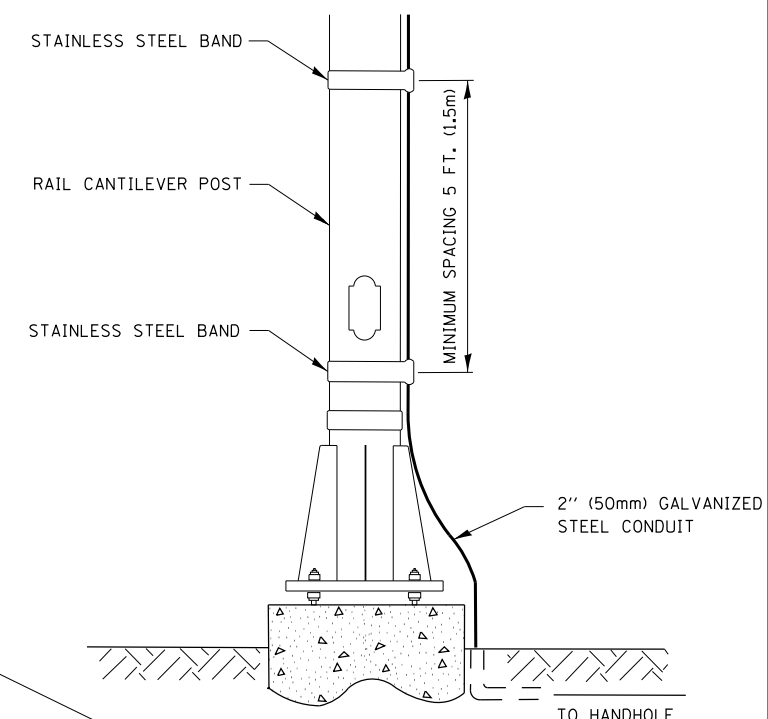

SIGNAL CONDUIT CONNECTION TO RAIL CANTILEVER DETAIL

USE NON-CONDUCTIVE SPACERS BETWEEN THE TRAFFIC SIGNAL EQUIPMENT AND THE RAILROAD CANTILEVER TO PREVENT DISSIMILAR METAL CORROSION.

ALL DIMENSIONS ARE IN INCHES (MILLIMETERS) UNLESS OTHERWISE SHOWN.

IF RAILROAD CANTILEVER IS NON-EXISTANT AND NONE IS PROPOSED, THEN OVERHEAD TRAFFIC SIGNAL TO BE MOUNTED ON A SIGNAL MAST ARM. SIGNAL MAST ARM AND SIGNAL HEADS SHALL BE INSTALLED AS CLOSE AS PRACTICABLE TO THE RAILROAD TRACKS WITHOUT OBSTRUCTING ANY RAILROAD WARNING DEVICES. SIGNAL MAST ARM SHALL BE AT LEAST 12 FT. FROM NEAREST RAIL.

FILE NAME =	USER NAME = footemj	DESIGNED -	REVISED - 02-25-11	STATE OF ILLINOIS DEPARTMENT OF TRANSPORTATION	TYPICAL SUPPLEMENTAL SIGNING AND PAVEMENT MARKING TREATMENT FOR RAILROAD CROSSINGS	F.A.U. R.T.E.	SECTION	COUNTY	TOTAL SHEETS	SHEET NO.
pw:\IL084EBIDINTEG\illinois.gov\PWIDOT\Documents\DOT Offices\District 1\Projects\Dist 1\DRAWING\CADDData\CADsheets\tc23.dgn	PLOT SCALE = 50.000' / in.	CHECKED -	REVISED - 04-26-12			0297	3178G-N(14)	COOK	151	121
Default	PLOT DATE = 1/3/2017	DATE -	REVISED - A.R. 07-11-16			TC-23		CONTRACT NO. 60Y26		
						ILLINOIS FED. AID PROJECT				

SCALE: NONE SHEET 1 OF 2 SHEETS STA. TO STA.

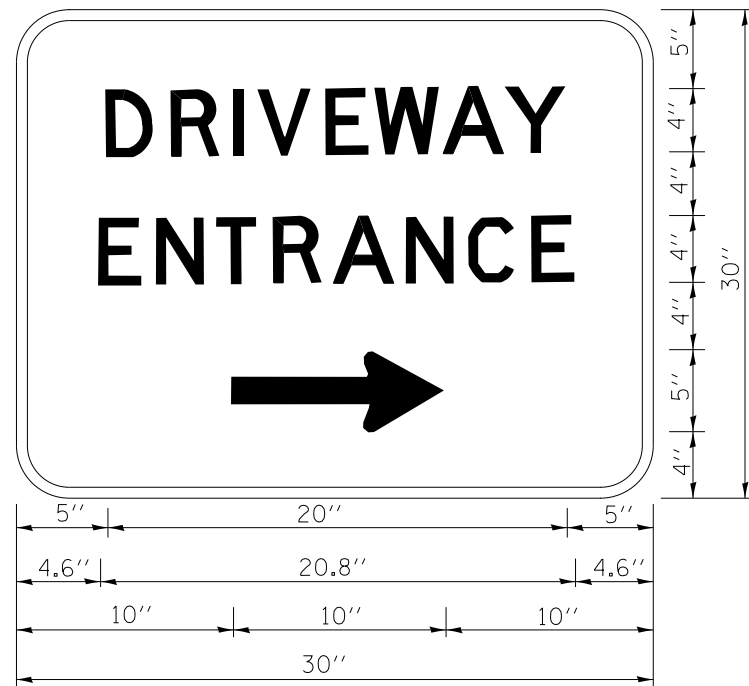

3.0" RADIUS, 0.5" BORDER, WHITE ON GREEN; REFLECTORIZED
 "DRIVEWAY" D; "ENTRANCE" D; STANDARD ARROW CUSTOM 12.0" x 5.0"

NOTES:

1. HALF OF THE SIGNS WILL REQUIRE A LEFT HAND FACING ARROW.
2. TWO SIGNS SHALL BE USED AT EACH COMMERCIAL ENTRANCE
 PLACED BACK-TO-BACK; ONE WITH A RIGHT HAND ARROW (SHOWN)
 SHALL BE PLACED ON THE NEAR RIGHT SIDE THE DRIVEWAY
 AND ONE WITH A LEFT HAND ARROW SHALL BE PLACED ON THE
 FAR LEFT SIDE OF THE DRIVEWAY.
3. SIGNS TO BE PAID FOR AS ITEM "TEMPORARY INFORMATION SIGNING".

FILE NAME =	USER NAME = gegl1enobt	DESIGNED -	REVISED - C. JUCIUS 02-15-07
ct:\pwork\pwork\gagl1enobt\d0108315\to26.dgn		DRAWN -	REVISED -
	PLOT SCALE = 50.000' / in.	CHECKED -	REVISED -
	PLOT DATE = 12/13/2012	DATE -	REVISED -

**STATE OF ILLINOIS
 DEPARTMENT OF TRANSPORTATION**

DRIVEWAY ENTRANCE SIGNING

SCALE: NONE SHEET NO. 1 OF 1 SHEETS STA. TO STA.

F.A.U. RTE.	SECTION	COUNTY	TOTAL SHEETS	SHEET NO.
297	3178G-N(14)	COOK	151	123
TC-26			CONTRACT NO. 60Y26	
FED. ROAD DIST. NO. 1 ILLINOIS FED. AID PROJECT				

FINAL SURVEY	SURVEYED	BY	DATE
NOTE BOOK	PLOTTED		
AREAS CHECKED	TEMPLATE		
NO.	AREAS CHECKED		

ORIGINAL SURVEY	SURVEYED	BY	DATE
NOTE BOOK	PLOTTED		
AREAS CHECKED	TEMPLATE		
NO.	AREAS CHECKED		

FILE NAME = D:\Engineering\Live\Projects\13003\DOT DUR\30933 - WD 4 Contract No. 60Y26\CADD\CADD Sheets\Civil\DOT60Y26-int-xUS5Swale.dgn

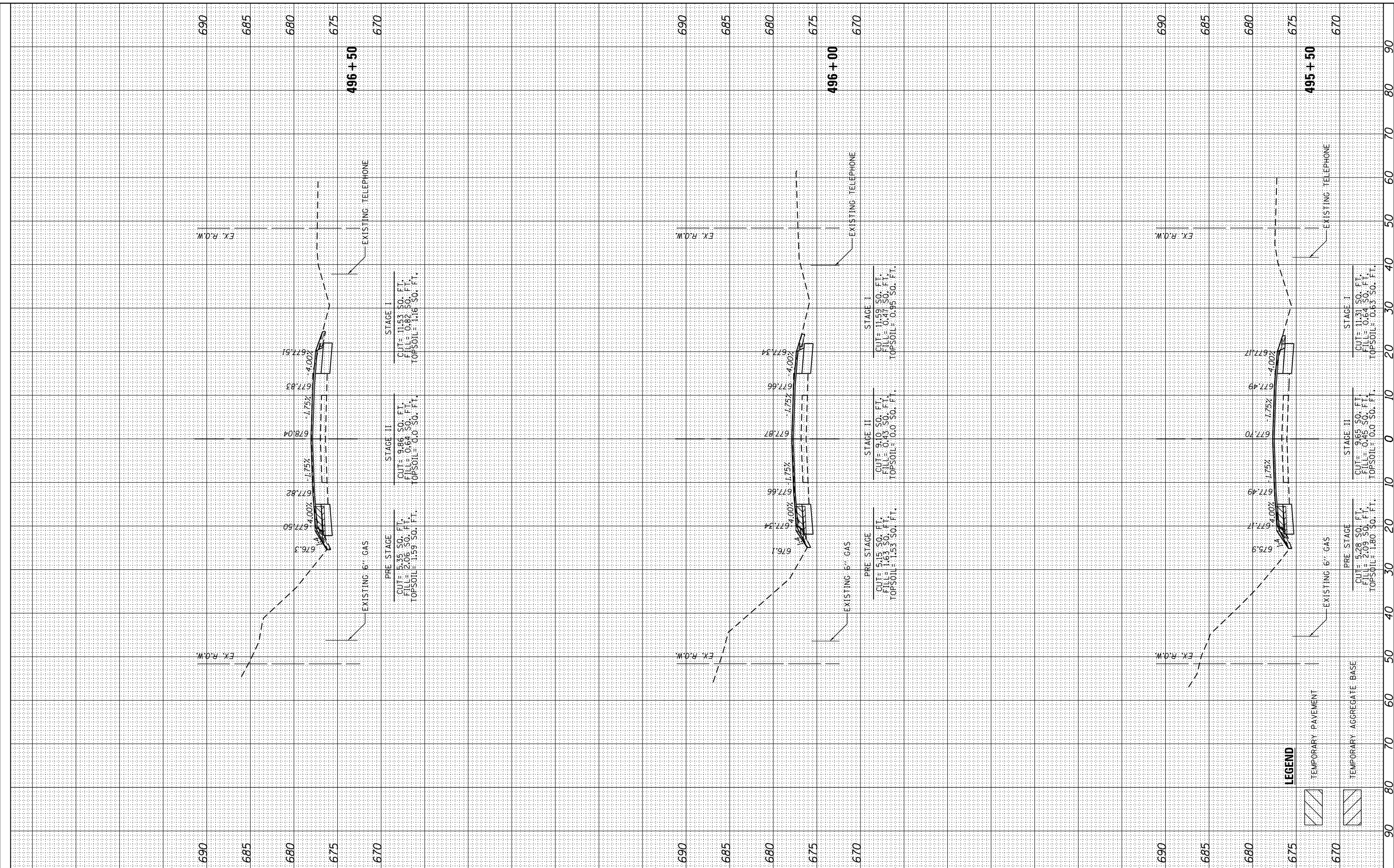

USER NAME = johnn	DESIGNED - TGM	REVISED -
PLOT SCALE = 20.0000' / in.	DRAWN - CC	REVISED -
PLOT DATE = 2/2/2018	CHECKED - JMT	REVISED -
	DATE - 10-15-2014	REVISED -

DESIGNED - TGM	REVISED -
DRAWN - CC	REVISED -
CHECKED - JMT	REVISED -
DATE - 10-15-2014	REVISED -

STATE OF ILLINOIS
DEPARTMENT OF TRANSPORTATION

CROSS SECTIONS STA. 495+50 TO STA. 496+50
US 6 (SOUTHWEST HWY.)
SCALE: SHEET 3 OF 13 SHEETS STA. 495+50 TO STA. 496+50

F.A.U. RTE. 0297	SECTION 3178C-N(14)	COUNTY COOK	TOTAL SHEETS 151	SHEET NO. 126
CONTRACT NO. 60Y26				ILLINOIS FED. AID PROJECT

LEGEND

- TEMPORARY PAVEMENT
- TEMPORARY AGGREGATE BASE



FINAL SURVEY	SURVEYED	BY	DATE
NOTE BOOK	PLOTTED		
AREAS CHECKED	TEMPLATE		
AREAS CHECKED	AREAS CHECKED		

ORIGINAL SURVEY	SURVEYED	BY	DATE
NOTE BOOK	PLOTTED		
AREAS CHECKED	TEMPLATE		
AREAS CHECKED	AREAS CHECKED		

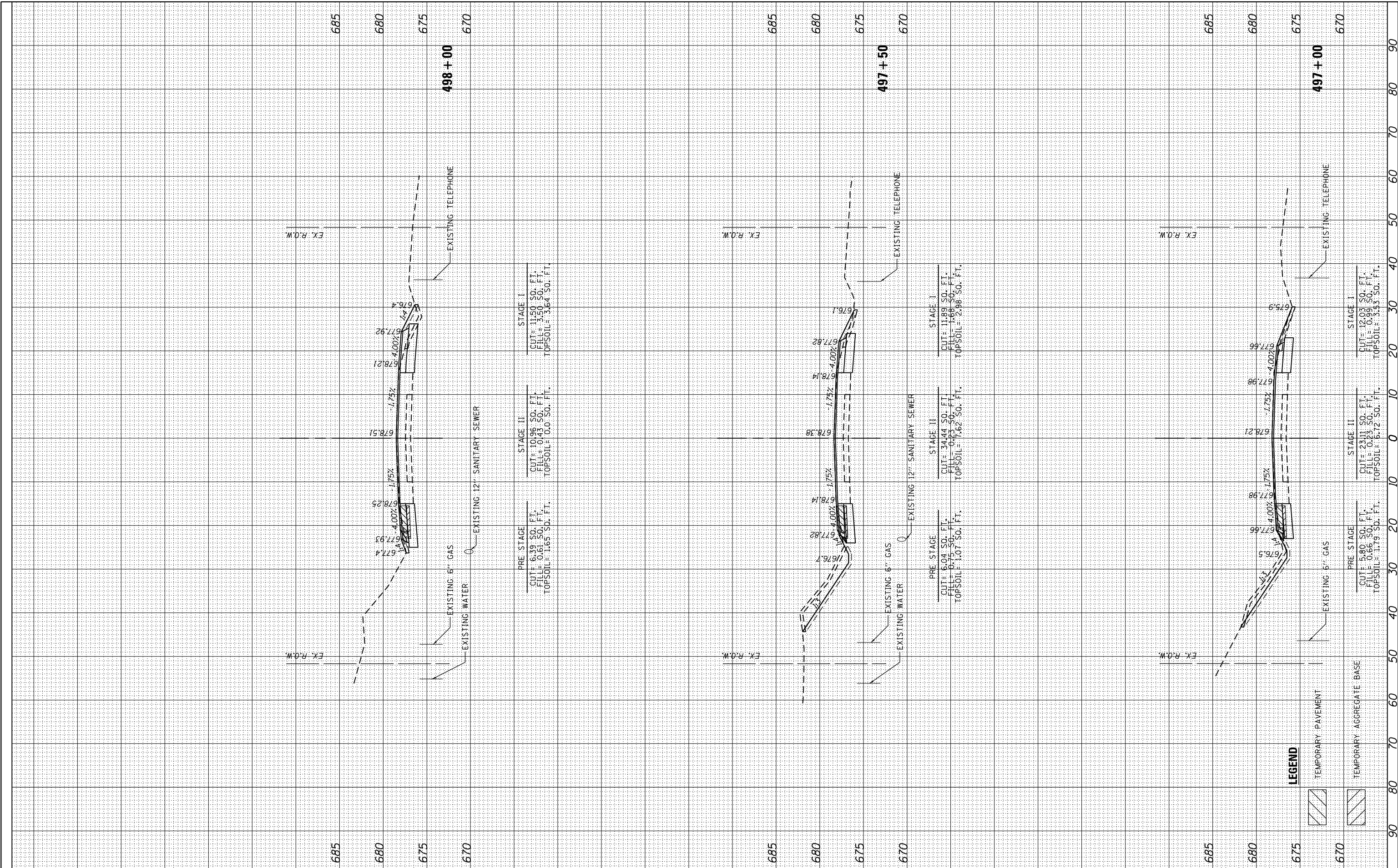
FILE NAME = D:\Engineering\Live\Projects\13003\DOT DURV\30933 - WD 4 Contract No. 60Y26\CADD\CADD Sheets\Civil\DOT60Y26-int-xUS5Swale.dgn



LEGEND

-  TEMPORARY PAVEMENT
-  TEMPORARY AGGREGATE BASE



USER NAME = johnn	DESIGNED - TGM	REVISED -
PLOT SCALE = 20.0000' / in.	DRAWN - CC	REVISED -
PLOT DATE = 2/2/2018	CHECKED - JMT	REVISED -
	DATE - 10-15-2014	REVISED -

**STATE OF ILLINOIS
DEPARTMENT OF TRANSPORTATION**

**CROSS SECTIONS STA. 497+00 TO STA. 498+00
US 6 (SOUTHWEST HWY.)**

F.A.U. RTE.	SECTION	COUNTY	TOTAL SHEETS	SHEET NO.
0297	3178G-N(14)	COOK	151	127
CONTRACT NO. 60Y26				
ILLINOIS FED. AID PROJECT				

SCALE: SHEET 4 OF 13 SHEETS STA. 497+00 TO STA. 498+00

FINAL SURVEY PLOTTED	BY	DATE
NOTE BOOK		
AREAS CHECKED		
AREAS CHECKED		

ORIGINAL SURVEY PLOTTED	BY	DATE
NOTE BOOK		
AREAS CHECKED		
AREAS CHECKED		

FILE NAME = D:\Engineering\Live\Projects\13003\DOT DURV\2003B - WD 4 Contract No. 60Y26\CADD\CADD Sheets\Civil\0160Y26-int-xUS\$Swale.dgn

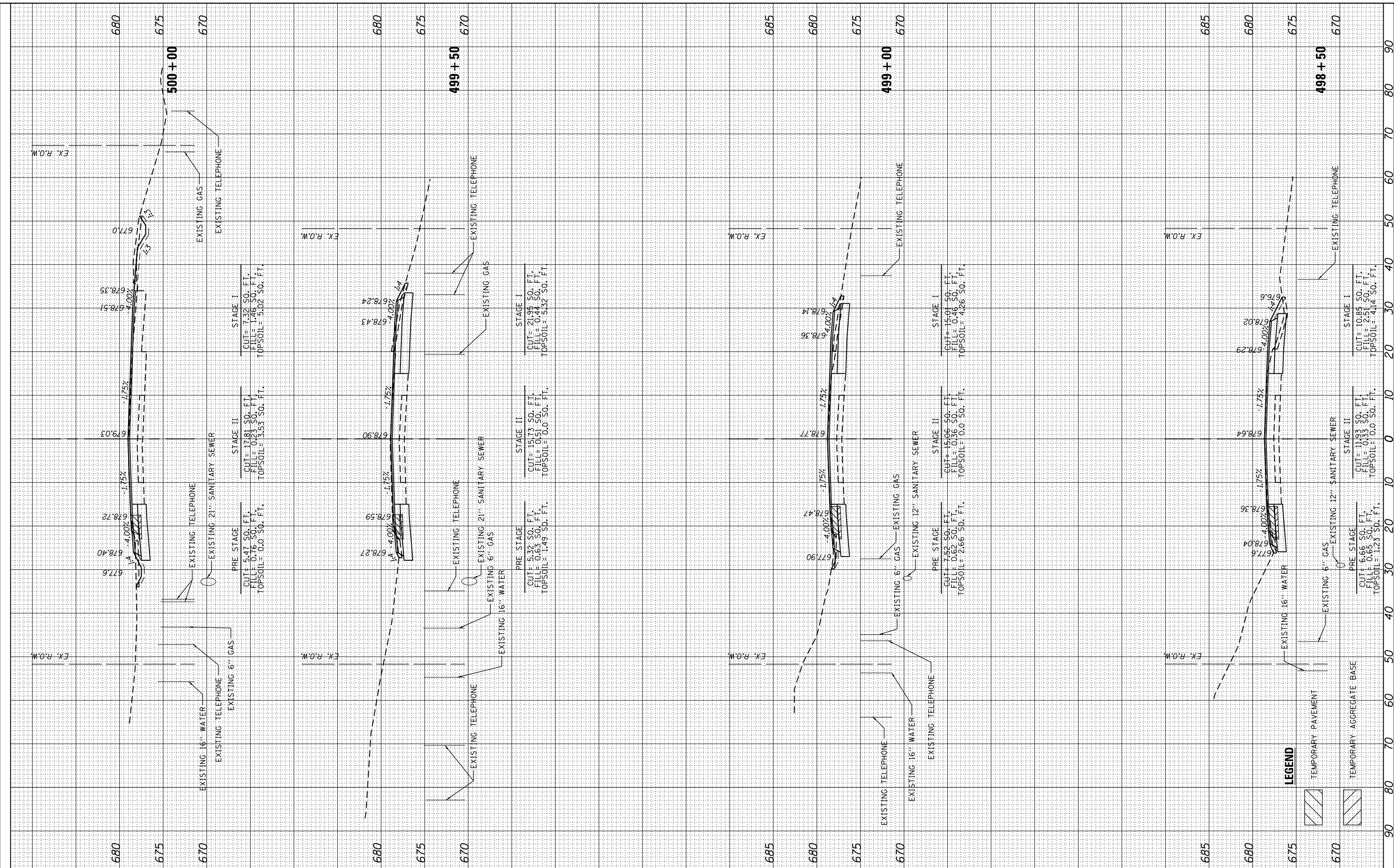

USER NAME = johnn	DESIGNED - TGM	REVISIONS
PLOT SCALE = 20.0000' / in.	DRAWN - CC	REVISIONS
PLOT DATE = 2/2/2018	CHECKED - JMT	REVISIONS
	DATE - 101-15-2014	REVISIONS

REVISIONS	REVISIONS	REVISIONS
REVISIONS	REVISIONS	REVISIONS
REVISIONS	REVISIONS	REVISIONS
REVISIONS	REVISIONS	REVISIONS

**STATE OF ILLINOIS
DEPARTMENT OF TRANSPORTATION**

**CROSS SECTIONS STA. 498 + 50 TO STA. 500 + 00
US 6 (SOUTHWEST HWY.)**

F.A.U. RTE.	SECTION	COUNTY	TOTAL SHEETS	SHEET NO.
0297	3178G-N(14)	COOK	151	128
CONTRACT NO. 60Y26				
ILLINOIS FED. AID PROJECT				

SCALE: SHEET 5 OF 13 SHEETS STA. 498+50 TO STA. 500+00

LEGEND

- TEMPORARY PAVEMENT
- TEMPORARY AGGREGATE BASE

FINAL SURVEY	SURVEYED	BY	DATE
NOTE BOOK	PLOTTED		
AREAS CHECKED	TEMPLATE		
AREAS CHECKED	AREAS CHECKED		

ORIGINAL SURVEY	SURVEYED	BY	DATE
NOTE BOOK	PLOTTED		
AREAS CHECKED	TEMPLATE		
AREAS CHECKED	AREAS CHECKED		

FILE NAME = D:\Engineering\Live\Projects\13003\DOT DUR\30933 - WD 4 Contract No. 60Y26\CADD\CADD Sheets\Civil\DOT\60Y26-int-xUS5Swale.dgn

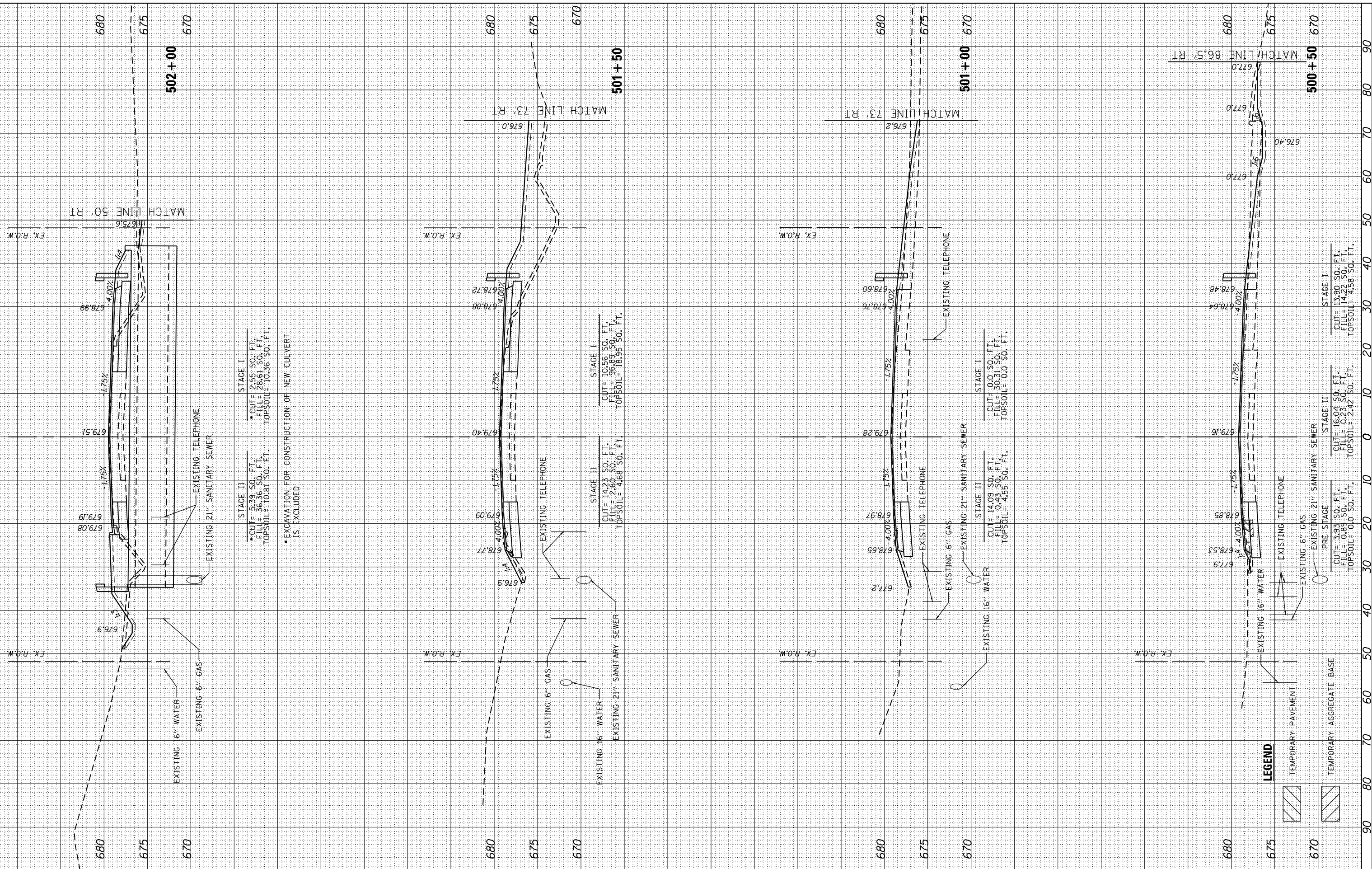

STAGE II
 CUT = 5.39 SO. FT.
 FILL = 36.36 SO. FT.
 TOPSOIL = 10.81 SO. FT.

STAGE I
 CUT = 2.55 SO. FT.
 FILL = 28.61 SO. FT.
 TOPSOIL = 10.36 SO. FT.

*EXCAVATION FOR CONSTRUCTION OF NEW CULVERT IS EXCLUDED

STAGE II
 CUT = 14.23 SO. FT.
 FILL = 2.60 SO. FT.
 TOPSOIL = 4.68 SO. FT.

STAGE I
 CUT = 10.56 SO. FT.
 FILL = 30.83 SO. FT.
 TOPSOIL = 18.93 SO. FT.

STAGE II
 CUT = 14.09 SO. FT.
 FILL = 0.43 SO. FT.
 TOPSOIL = 4.55 SO. FT.

STAGE I
 CUT = 0.0 SO. FT.
 FILL = 30.31 SO. FT.
 TOPSOIL = 0.0 SO. FT.

STAGE II
 CUT = 3.93 SO. FT.
 FILL = 0.89 SO. FT.
 TOPSOIL = 0.0 SO. FT.

STAGE I
 CUT = 13.90 SO. FT.
 FILL = 14.22 SO. FT.
 TOPSOIL = 4.58 SO. FT.

LEGEND

[Symbol]	TEMPORARY PAVEMENT
[Symbol]	TEMPORARY AGGREGATE BASE



USER NAME = johnn	DESIGNED - TGM	REVISED -
PLOT SCALE = 20.0000' / in.	DRAWN - CC	REVISED -
PLOT DATE = 2/2/2018	CHECKED - JMT	REVISED -
	DATE - 10-15-2014	REVISED -

**STATE OF ILLINOIS
 DEPARTMENT OF TRANSPORTATION**

**CROSS SECTIONS STA. 500+50 TO STA. 502+00
 US 6 (SOUTHWEST HWY.)**

SCALE: SHEET 6 OF 13 SHEETS STA. 500+50 TO STA. 502+00

F.A.U. RTE. 0297	SECTION 3178G-N(14)	COUNTY COOK	TOTAL SHEETS 151	SHEET NO. 129
CONTRACT NO. 60Y26				ILLINOIS FED. AID PROJECT

FINAL SURVEY	SURVEYED	BY	DATE
NOTE BOOK	PLOTTED		
AREAS CHECKED	TEMPLATE		
NO.	AREAS CHECKED		

ORIGINAL SURVEY	SURVEYED	BY	DATE
NOTE BOOK	PLOTTED		
AREAS CHECKED	TEMPLATE		
NO.	AREAS CHECKED		

FILE NAME = D:\Engineering\Live\Projects\13003\DOT DUV\30933 - WD 4 Contract No. 60Y26\CADD\CADD Sheets\Civil\DOT60Y26-int-xUS5Swale.dgn

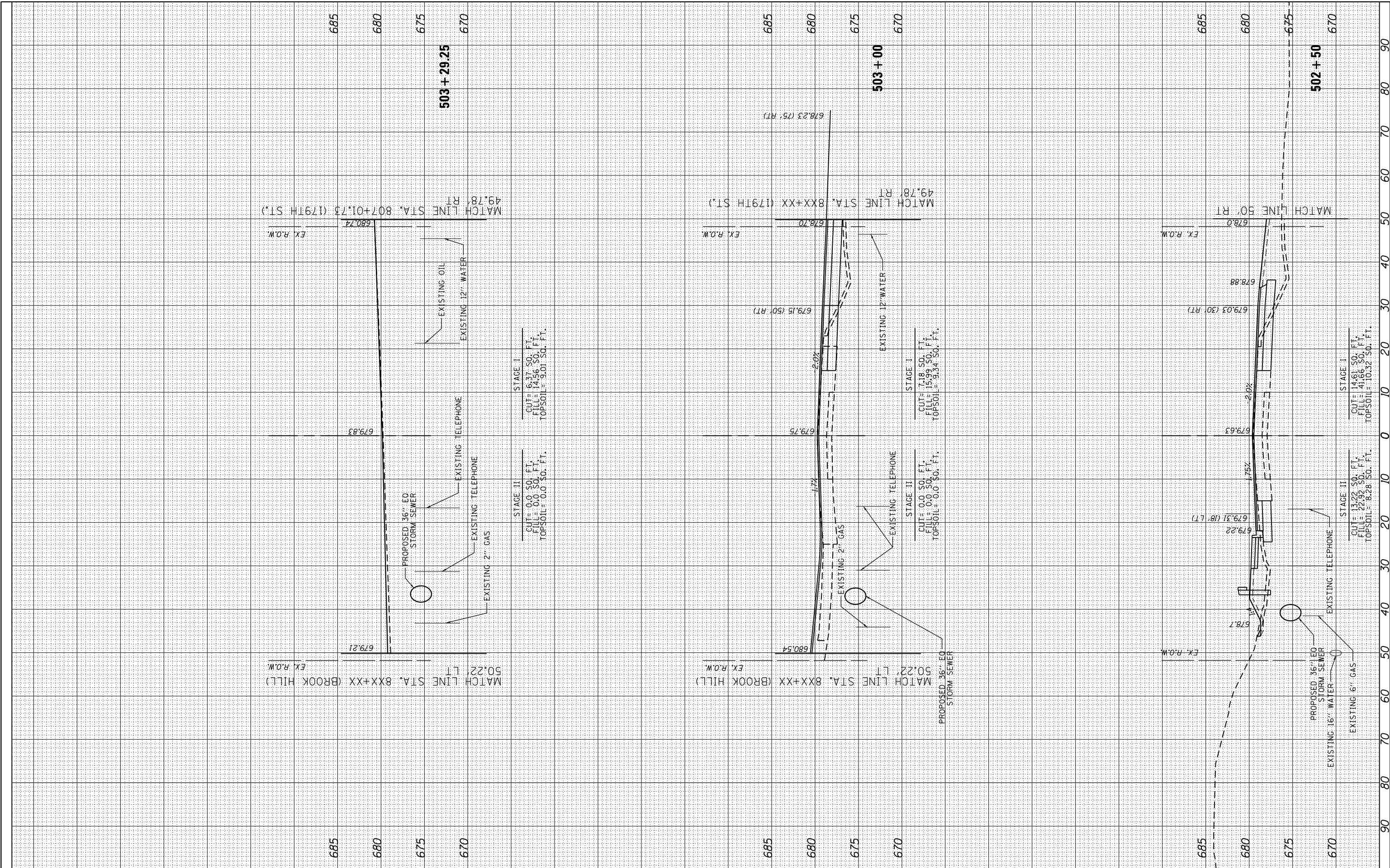

USER NAME = johnn	DESIGNED - TGM	REVISED -
PLOT SCALE = 20.0000' / 1" = 20.0000'	DRAWN - CC	REVISED -
PLOT DATE = 2/2/2018	CHECKED - JMT	REVISED -
	DATE - 10-15-2014	REVISED -

DESIGNED - TGM	REVISED -
DRAWN - CC	REVISED -
CHECKED - JMT	REVISED -
DATE - 10-15-2014	REVISED -

**STATE OF ILLINOIS
DEPARTMENT OF TRANSPORTATION**

CROSS SECTIONS STA. 502+50 TO STA. 503+14.60 US 6 (SOUTHWEST HWY.)			
SCALE:	SHEET 7	OF 13 SHEETS	STA. 502+50 TO STA. 503+14.60

F.A.U. RTE.	SECTION	COUNTY	TOTAL SHEETS	SHEET NO.
0297	3178G-N(14)	COOK	151	130
CONTRACT NO. 60Y26				
ILLINOIS FED. AID PROJECT				

FINAL SURVEY	SURVEYED	BY	DATE
NOTE BOOK	PLOTTED		
NO.	TEMPLATE		
	AREAS CHECKED		
	AREAS CHECKED		

ORIGINAL SURVEY	SURVEYED	BY	DATE
NOTE BOOK	PLOTTED		
NO.	TEMPLATE		
	AREAS CHECKED		
	AREAS CHECKED		

FILE NAME = D:\Engineering\Live\Projects\13003\DOT DUR\30939 - WD 4 Contract No. 60Y26\CADD\CADD Sheets\Civil\DOT60Y26-int-xUS5Swale.dgn

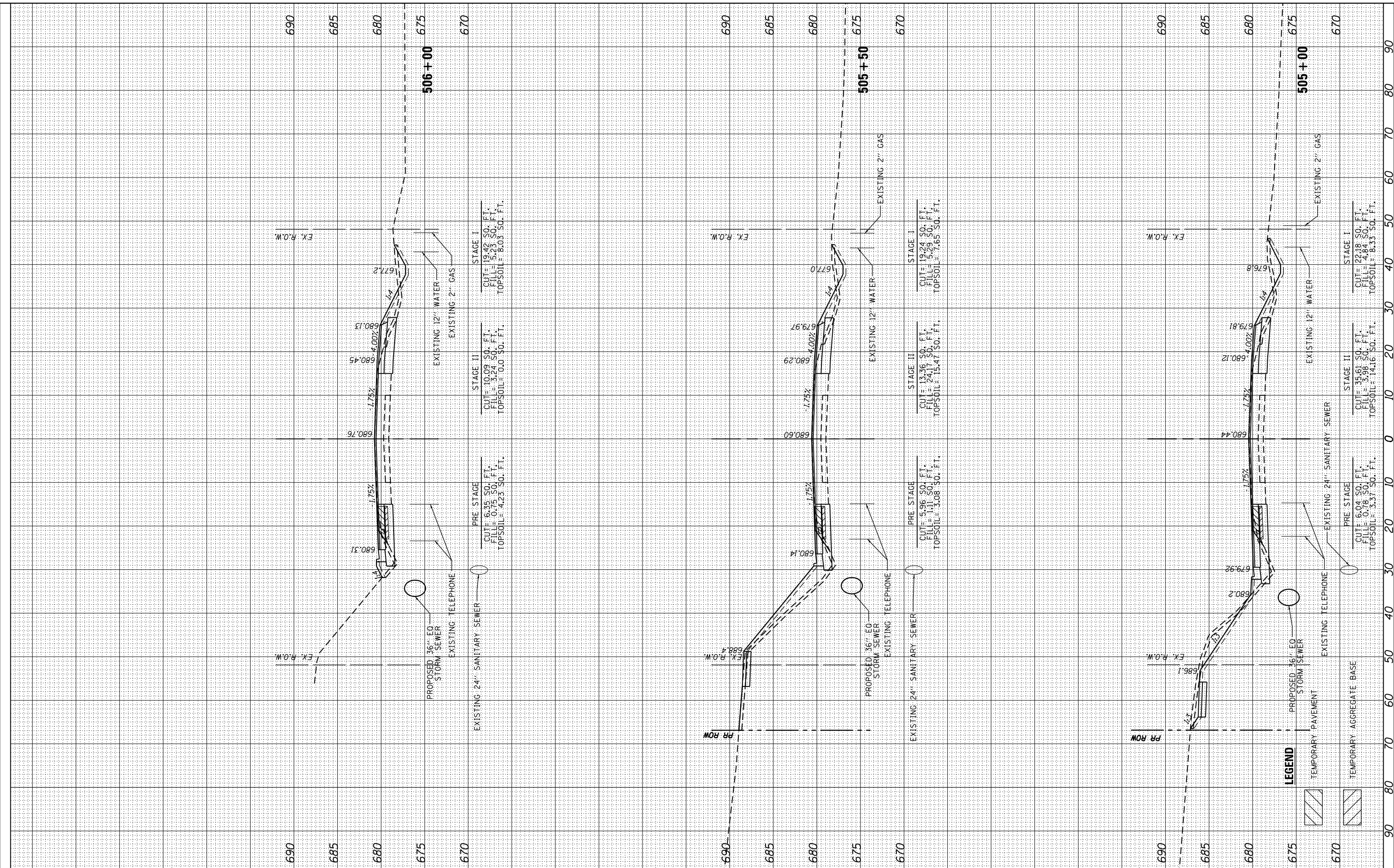

USER NAME = johnn	DESIGNED - TGM	REVISED -
	DRAWN - CC	REVISED -
PLOT SCALE = 20.0000' / in.	CHECKED - JMT	REVISED -
PLOT DATE = 2/2/2018	DATE - 10-15-2014	REVISED -

DESIGNED - TGM	REVISED -
DRAWN - CC	REVISED -
CHECKED - JMT	REVISED -
DATE - 10-15-2014	REVISED -

**STATE OF ILLINOIS
DEPARTMENT OF TRANSPORTATION**

**CROSS SECTIONS STA. 505+00 TO STA. 506+00
US 6 (SOUTHWEST HWY.)**

SCALE: SHEET 9 OF 13 SHEETS STA. 505+00 TO STA. 506+00

F.A.U. RTE.	SECTION	COUNTY	TOTAL SHEETS	SHEET NO.
0297	3178G-N(14)	COOK	151	132
CONTRACT NO. 60Y26				
ILLINOIS FED. AID PROJECT				

FINAL SURVEY	SURVEYED	BY	DATE
NOTE BOOK	PLOTTED		
AREAS CHECKED	TEMPLATE		
NO.	AREAS CHECKED		

ORIGINAL SURVEY	SURVEYED	BY	DATE
NOTE BOOK	PLOTTED		
AREAS CHECKED	TEMPLATE		
NO.	AREAS CHECKED		

FILE NAME = D:\Engineering\Live\Projects\13003 IDOT DUV\30933 - WD 4 Contract No. 60Y26\CADD\CADD Sheets\Civil\13003\60Y26-int-xUS5Swal.dgn

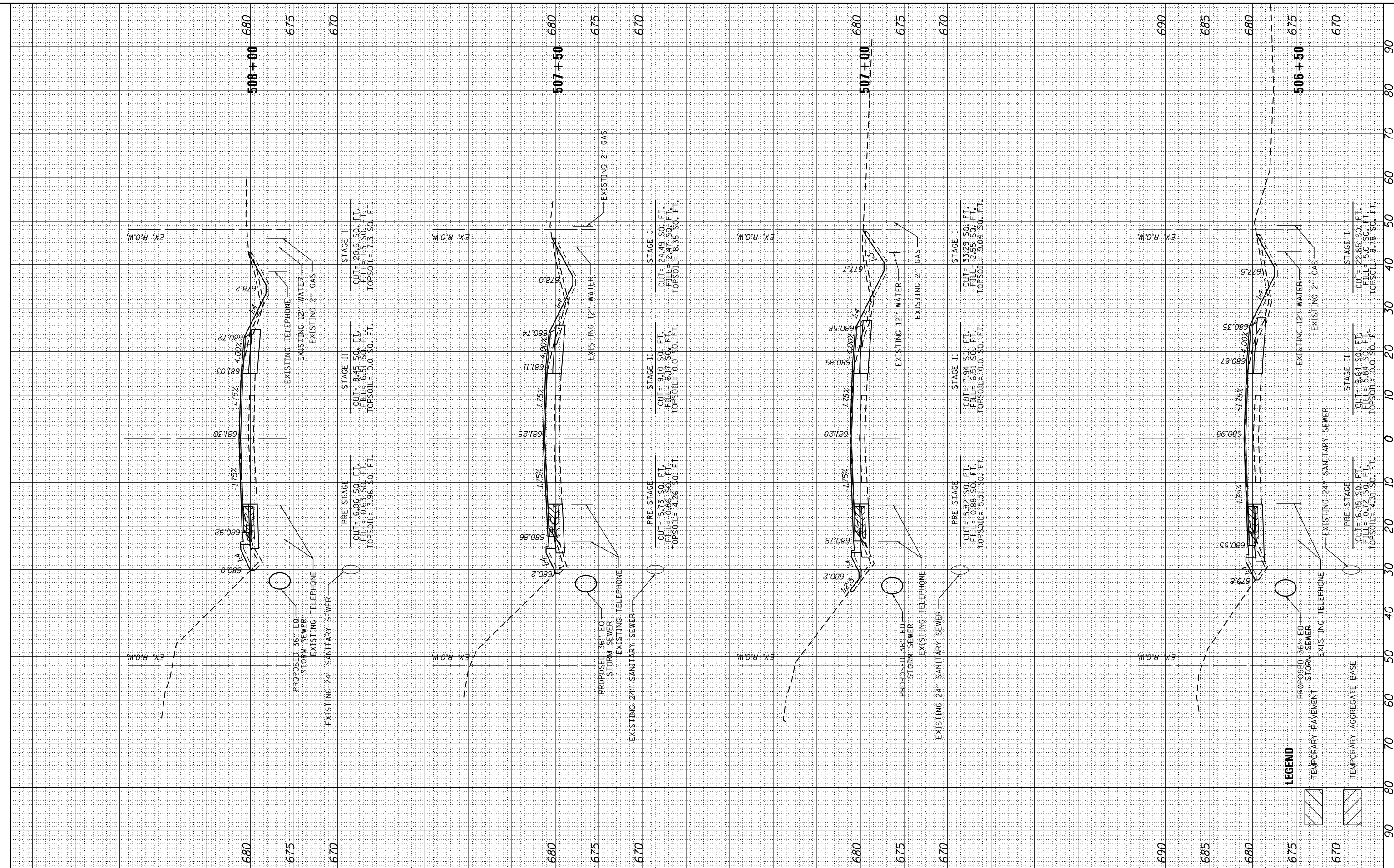

LEGEND

- TEMPORARY PAVEMENT
- TEMPORARY AGGREGATE BASE



USER NAME = johnn	DESIGNED - TGM	REVISED -
PLOT SCALE = 20.0000' / in.	DRAWN - CC	REVISED -
PLOT DATE = 2/2/2018	CHECKED - JMT	REVISED -
	DATE - 10-15-2014	REVISED -

**STATE OF ILLINOIS
DEPARTMENT OF TRANSPORTATION**

CROSS SECTIONS STA. 506+50 TO STA. 508+00			
US 6 (SOUTHWEST HWY.)			
SCALE:	SHEET 10	OF 13 SHEETS	STA. 506+50 TO STA. 508+00

F.A.U. RTE.	SECTION	COUNTY	TOTAL SHEETS	SHEET NO.
0297	3178G-N(14)	COOK	151	133
CONTRACT NO. 60Y26				
ILLINOIS FED. AID PROJECT				

FINAL SURVEY	SURVEYED	BY	DATE
NOTE BOOK	PLOTTED		
AREAS CHECKED	TEMPLATE		
	AREAS CHECKED		

ORIGINAL SURVEY	SURVEYED	BY	DATE
NOTE BOOK	PLOTTED		
AREAS CHECKED	TEMPLATE		
	AREAS CHECKED		

FILE NAME = G:\Engineering\Live\Projects\13003\DOT DUR\2023 - W4 Contract No. 60Y26\CADD\CADD Sheets\Civil\DOT\60Y26-int-cv\SS\swa1.dwg

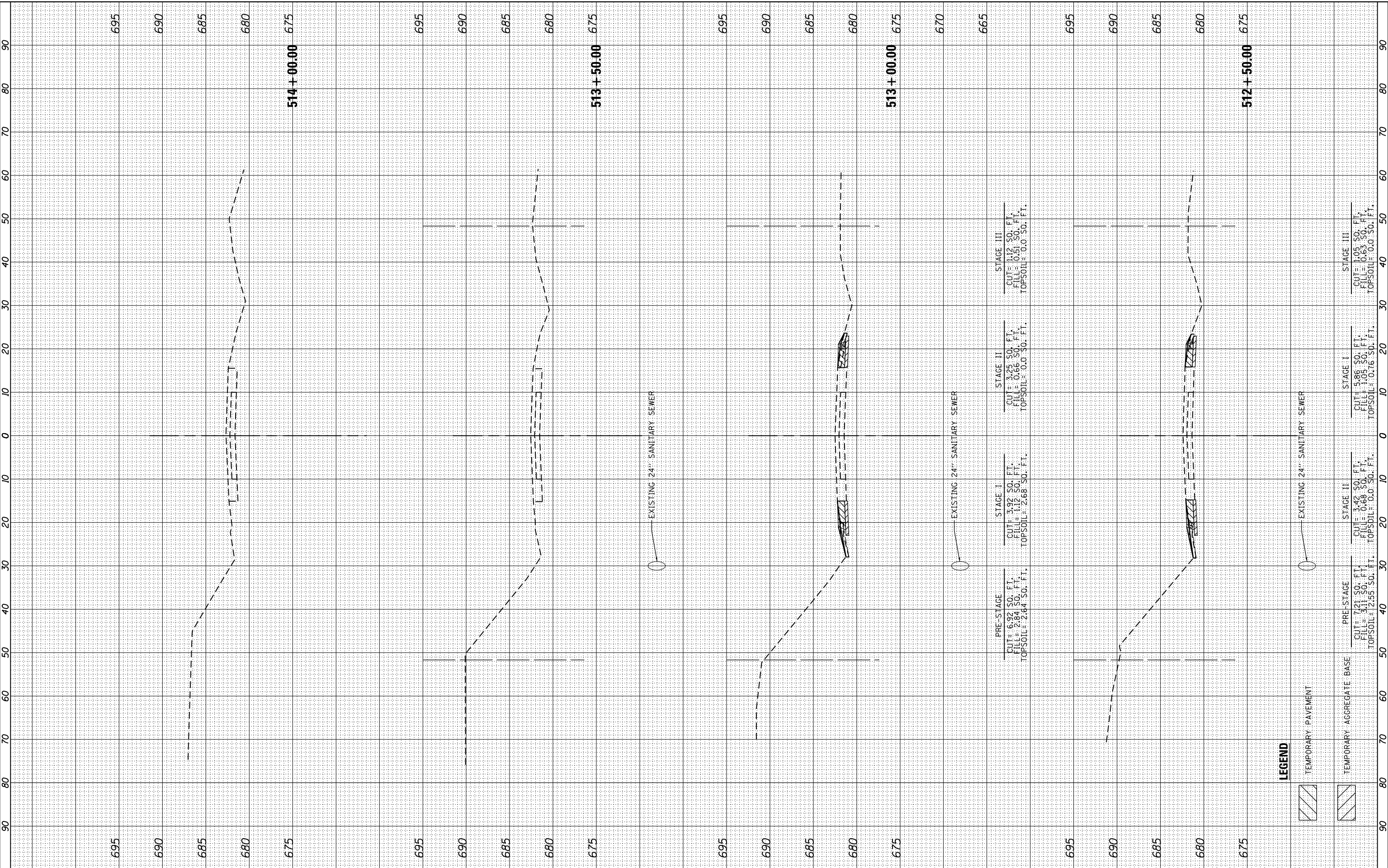

USER NAME = johnn	DESIGNED - TGM	REVISED -
PLOT SCALE = 20.0000' / in.	DRAWN - CC	REVISED -
PLOT DATE = 2/2/2018	CHECKED - JMT	REVISED -
	DATE - 10-15-2014	REVISED -

**STATE OF ILLINOIS
DEPARTMENT OF TRANSPORTATION**

CROSS SECTIONS STA. 512+50 TO STA. 514+00 US 6 (SOUTHWEST HWY.)		
SCALE:	SHEET 13 OF 13 SHEETS	STA. 512+50 TO STA. 514+00

F.A.U. RTE. 0297	SECTION 3178G-N(14)	COUNTY COOK	TOTAL SHEETS 151	SHEET NO. 136
CONTRACT NO. 60Y26				
ILLINOIS FED. AID PROJECT				

LEGEND

- TEMPORARY PAVEMENT
- TEMPORARY AGGREGATE BASE

FINAL SURVEY	SURVEYED	BY	DATE
NOTE BOOK	PLOTTED		
NO.	TEMPLATE		
	AREAS CHECKED		
	AREAS CHECKED		

ORIGINAL SURVEY	SURVEYED	BY	DATE
NOTE BOOK	PLOTTED		
NO.	TEMPLATE		
	AREAS CHECKED		
	AREAS CHECKED		

FILE NAME = D:\Engineering\Live\Projects\13093\DOT\DOT\3093\NO 4 Contract No. 60Y26\CADD\CADD Sheets\Civil\DOT\60Y26-INT-XS\179THBROOK.dgn



USER NAME = MNeishapour1	DESIGNED - JN	REVISED -
	DRAWN - JN	REVISED -
PLOT SCALE = 20.0000' / in.	CHECKED - TGM	REVISED -
PLOT DATE = 2/2/2018	DATE - 01-29-2018	REVISED -

**STATE OF ILLINOIS
DEPARTMENT OF TRANSPORTATION**

**CROSS SECTIONS
BROOK HILL /179TH STREET**

SCALE: SHEET 1 OF 11 SHEETS STA. 804+00 TO STA. 804+50

F.A.U. RTE.	SECTION	COUNTY	TOTAL SHEETS	SHEET NO.
0297	3178G-N(14)	COOK	151	137
				CONTRACT NO. 60Y26
ILLINOIS FED. AID PROJECT				

FINAL SURVEY NO.	SURVEYED AREAS CHECKED	BY	DATE

ORIGINAL SURVEY NO.	SURVEYED AREAS CHECKED	BY	DATE

FILE NAME = D:\Engineering\Live\Projects\13093\DOT\DOT\13093 - NO 4 Contract No. 60Y26\CADD\CADD Sheets\Civil\DOT\60Y26 - st- XS179THBROOK.dgn

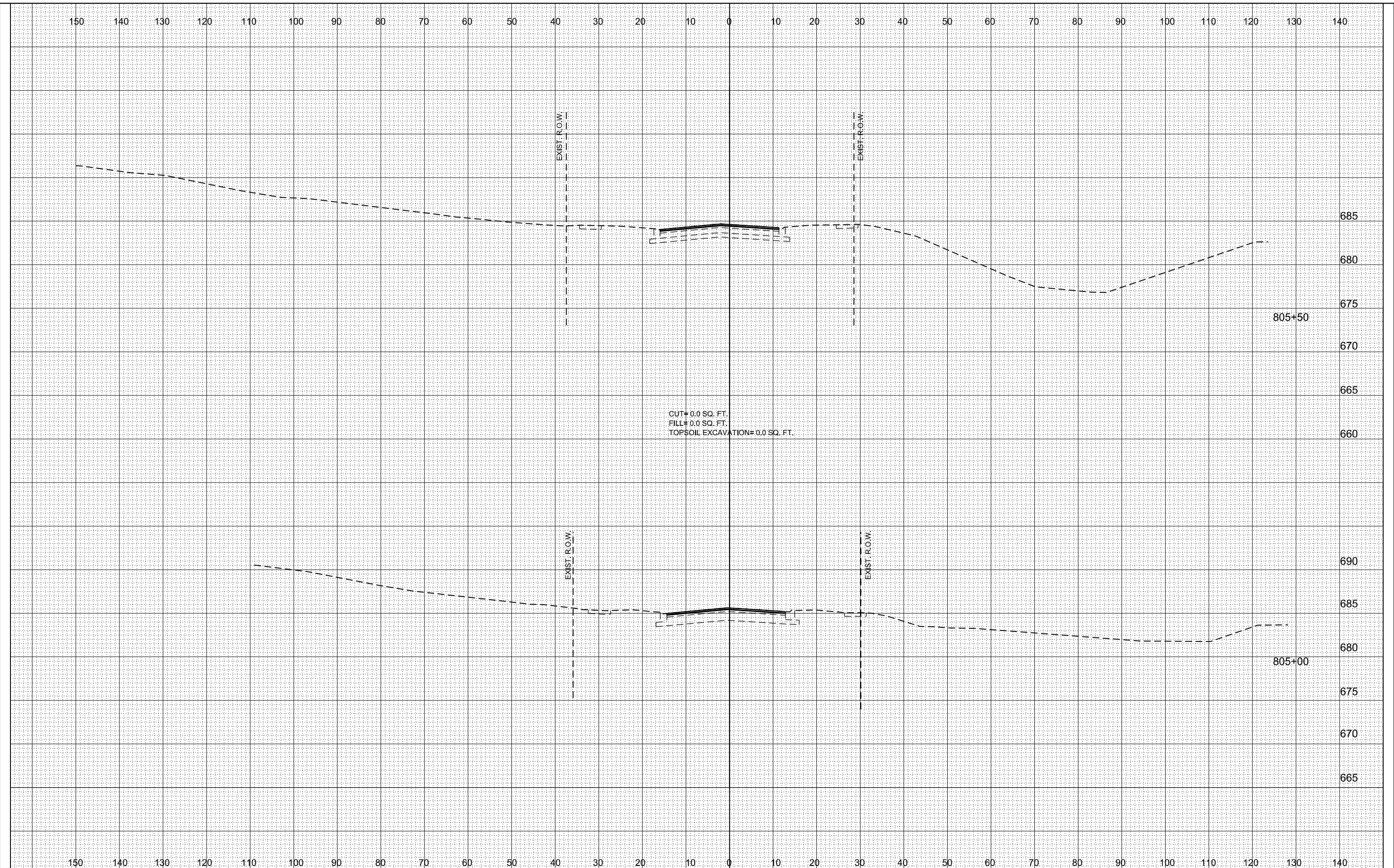

USER NAME = MNeishapour1	DESIGNED - JN	REVISED -
PLOT SCALE = 20.0000' / in.	DRAWN - JN	REVISED -
PLOT DATE = 2/2/2018	CHECKED - TGM	REVISED -
	DATE - 01-29-2018	REVISED -

**STATE OF ILLINOIS
DEPARTMENT OF TRANSPORTATION**

**CROSS SECTIONS
BROOK HILL /179TH STREET**

SCALE: SHEET 2 OF 11 SHEETS STA. 805+00 TO STA. 805+50

F.A.U. RTE.	SECTION	COUNTY	TOTAL SHEETS	SHEET NO.
0297	3178G-N(14)	COOK	151	138
CONTRACT NO. 60Y26				
ILLINOIS FED. AID PROJECT				

FINAL SURVEY	SURVEYED	BY	DATE
NOTE BOOK	PLOTTED		
AREAS CHECKED	TEMPLATE		
NO.	AREAS CHECKED		

ORIGINAL SURVEY	SURVEYED	BY	DATE
NOTE BOOK	PLOTTED		
AREAS CHECKED	TEMPLATE		
NO.	AREAS CHECKED		

FILE NAME = G:\Engineering\Live\Projects\13003\DOT\DOT\3003B - NO 4 Contract No. 60Y26\CADD\CADD Sheets\Civil\060Y26 - sht-53\118000.dgn

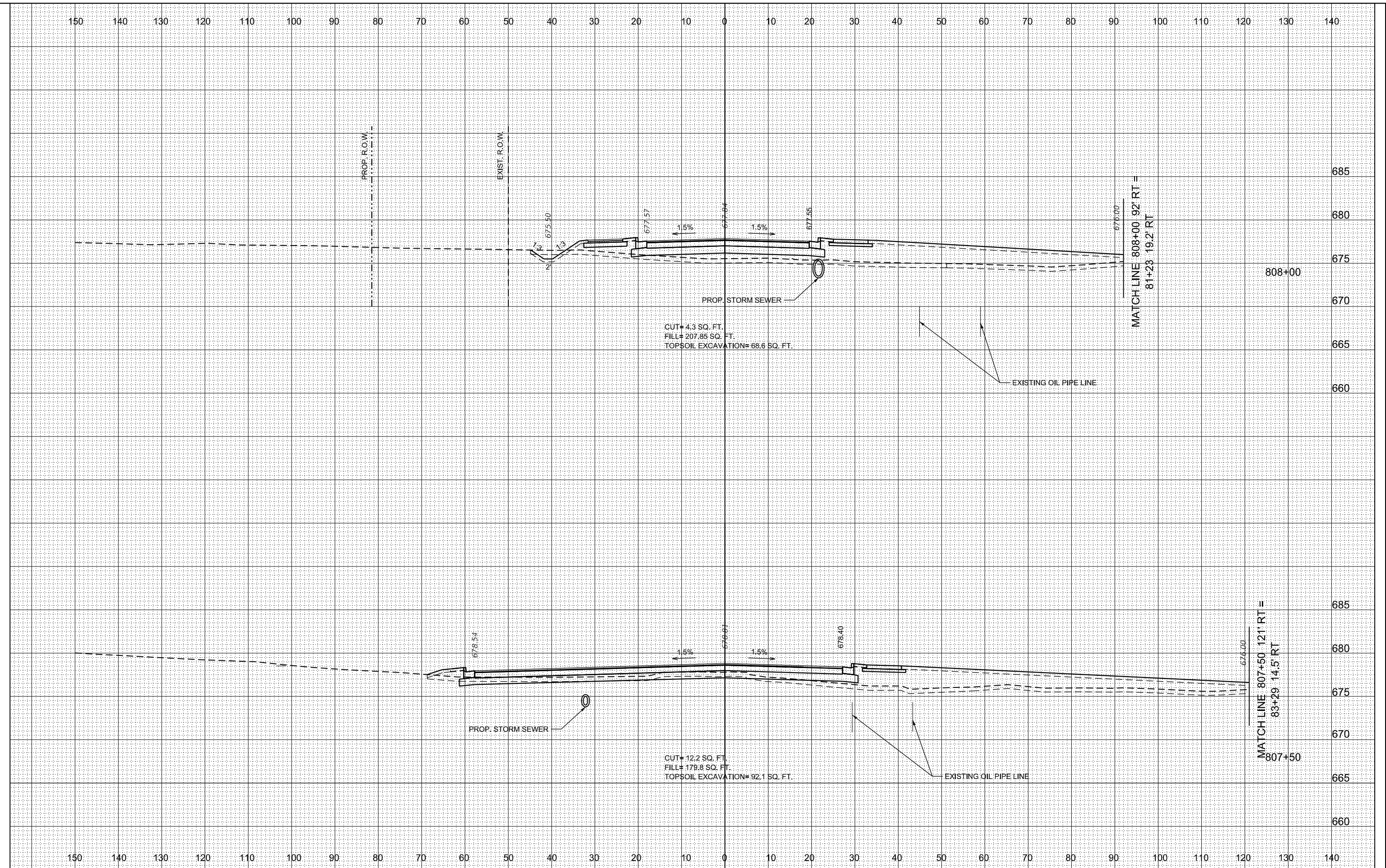

USER NAME = MNeishapour1	DESIGNED - JN	REVISED -
PLOT SCALE = 20.0000' / in.	DRAWN - JN	REVISED -
PLOT DATE = 2/2/2018	CHECKED - TGM	REVISED -
	DATE - 01-29-2018	REVISED -

**STATE OF ILLINOIS
DEPARTMENT OF TRANSPORTATION**

**CROSS SECTIONS
BROOK HILL /179TH STREET**

SCALE: SHEET 5 OF 11 SHEETS STA. 807+50 TO STA. 808+00

F.A.U. RTE.	SECTION	COUNTY	TOTAL SHEETS	SHEET NO.
0297	3178G-N(14)	COOK	151	141
CONTRACT NO. 60Y26				

ILLINOIS FED. AID PROJECT

DATE	
BY	
FINAL SURVEY	SURVEYED
NOTE BOOK	PLOTTED
NO.	TEMPLATE
	AREAS CHECKED

DATE	
BY	
ORIGINAL SURVEY	SURVEYED
NOTE BOOK	PLOTTED
NO.	TEMPLATE
	AREAS CHECKED

FILE NAME = D:\Engineering\Live\Projects\13803\DOT\DOT\38033 - NO 4 Contract No. 60Y26\CADD\CADD Sheets\Civil\DOT\60Y26-ent-XS179THBROOK.dgn

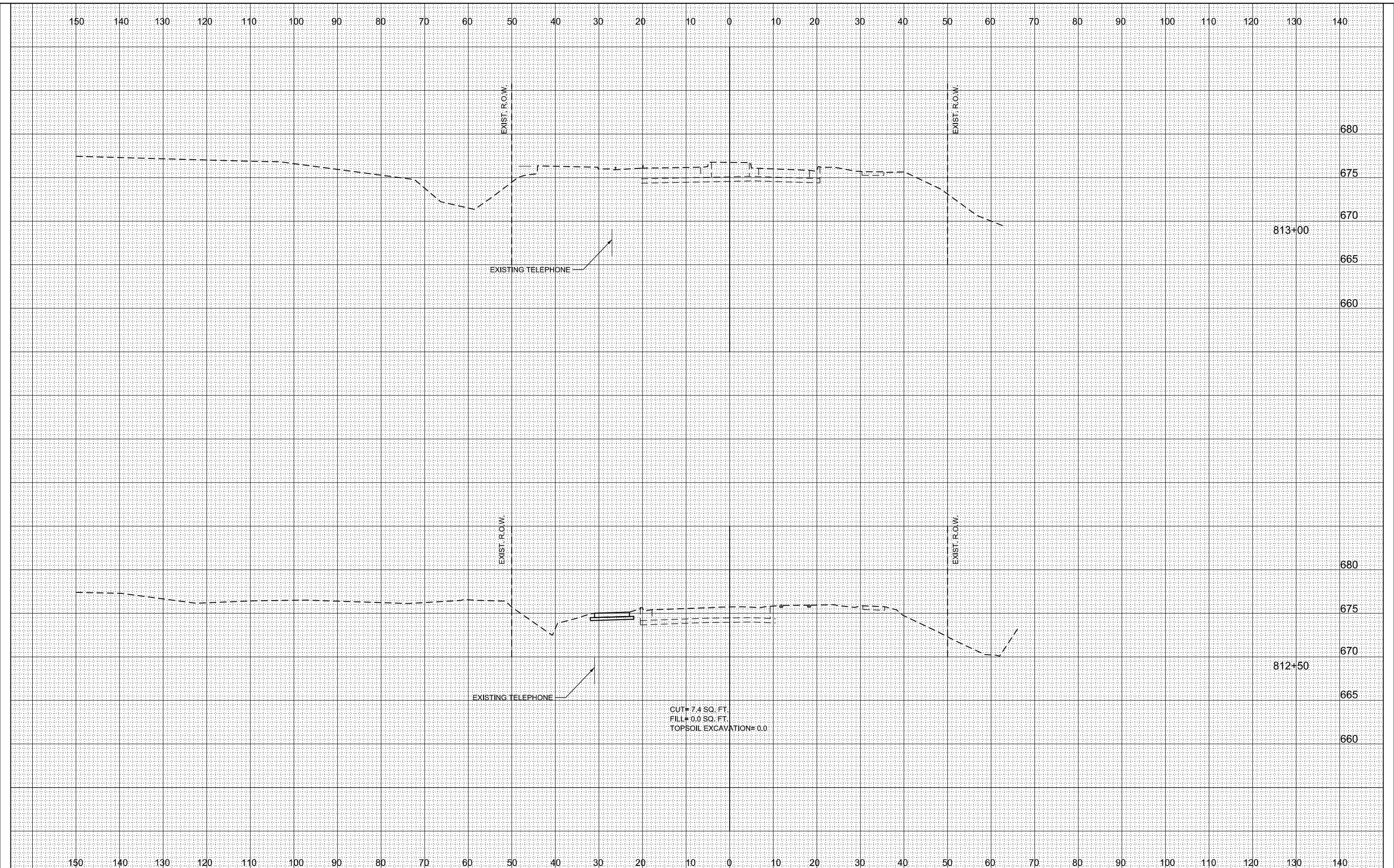

USER NAME = MNeishapour1	DESIGNED - JN	REVISED -
	DRAWN - JN	REVISED -
PLOT SCALE = 20.0000' / in.	CHECKED - TGM	REVISED -
PLOT DATE = 2/2/2018	DATE - 01-29-2018	REVISED -

**STATE OF ILLINOIS
DEPARTMENT OF TRANSPORTATION**

CROSS SECTIONS			
BROOK HILL / 179TH STREET			
SCALE:	SHEET 10	OF 11 SHEETS	STA. 812+50 TO STA. 813+00

F.A.U. RTE.	SECTION	COUNTY	TOTAL SHEETS	SHEET NO.
0297	3178G-N(14)	COOK	151	146
CONTRACT NO. 60Y26				
ILLINOIS FED. AID PROJECT				

FINAL SURVEY	SURVEYED	DATE
NOTE BOOK	PLOTTED	
NO.	TEMPLATE	
	AREAS CHECKED	
	AREAS CHECKED	

ORIGINAL SURVEY	SURVEYED	DATE
NOTE BOOK	PLOTTED	
NO.	TEMPLATE	
	AREAS CHECKED	
	AREAS CHECKED	

FILE NAME = D:\Engineering\Live\Projects\13003\DOT\DOT\30033 - MO 4 Contract No. 60Y26\CADD\CADD Sheets\Civil\DOT\60Y26-ent-XS179THBROOK.dgn

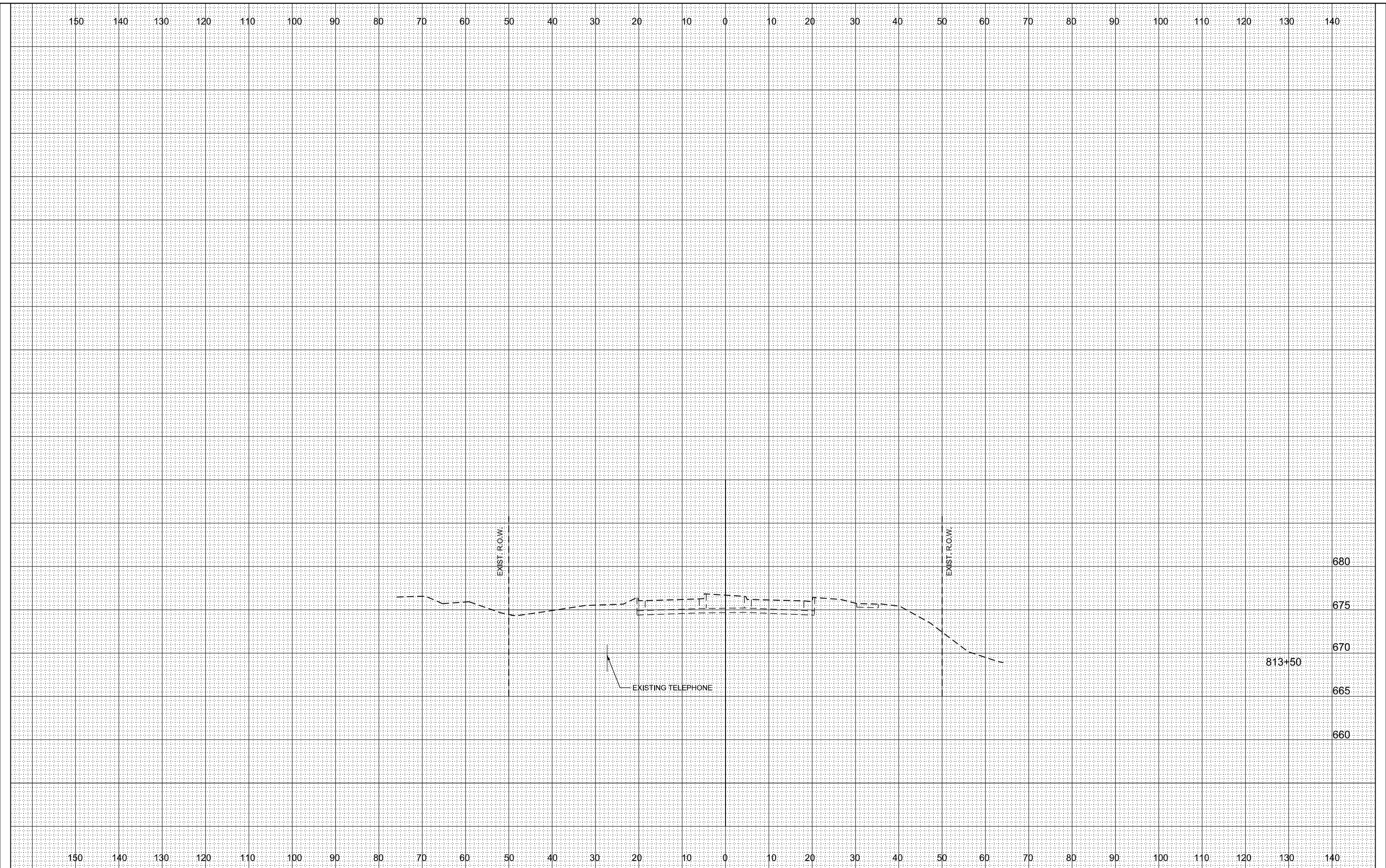

USER NAME = MNeishapour1	DESIGNED - JN	REVISED -
	DRAWN - JN	REVISED -
PLOT SCALE = 20.0000' / in.	CHECKED - TGM	REVISED -
PLOT DATE = 2/2/2018	DATE - 01-29-2018	REVISED -

**STATE OF ILLINOIS
DEPARTMENT OF TRANSPORTATION**

CROSS SECTIONS			
BROOK HILL /179TH STREET			
SCALE:	SHEET 11	OF 11 SHEETS	STA. 813+50 TO STA.

F.A.U. RTE.	SECTION	COUNTY	TOTAL SHEETS	SHEET NO.
0297	3178G-N(14)	COOK	151	147
CONTRACT NO. 60Y26				
ILLINOIS FED. AID PROJECT				

FINAL SURVEY	SURVEYED	BY	DATE
NOTE BOOK	PLOTTED		
AREAS CHECKED	TEMPLATE		
	AREAS		
	CHECKED		

ORIGINAL SURVEY	SURVEYED	BY	DATE
NOTE BOOK	PLOTTED		
AREAS CHECKED	TEMPLATE		
	AREAS		
	CHECKED		

FILE NAME = G:\Engineering\Irrigation\Projects\13003\DOT DURN\2025 - W4 - Contract No. 60Y25\CADD\CADD Sheets\Civil\DOT\80Y25-int-cv1585swale.dwg

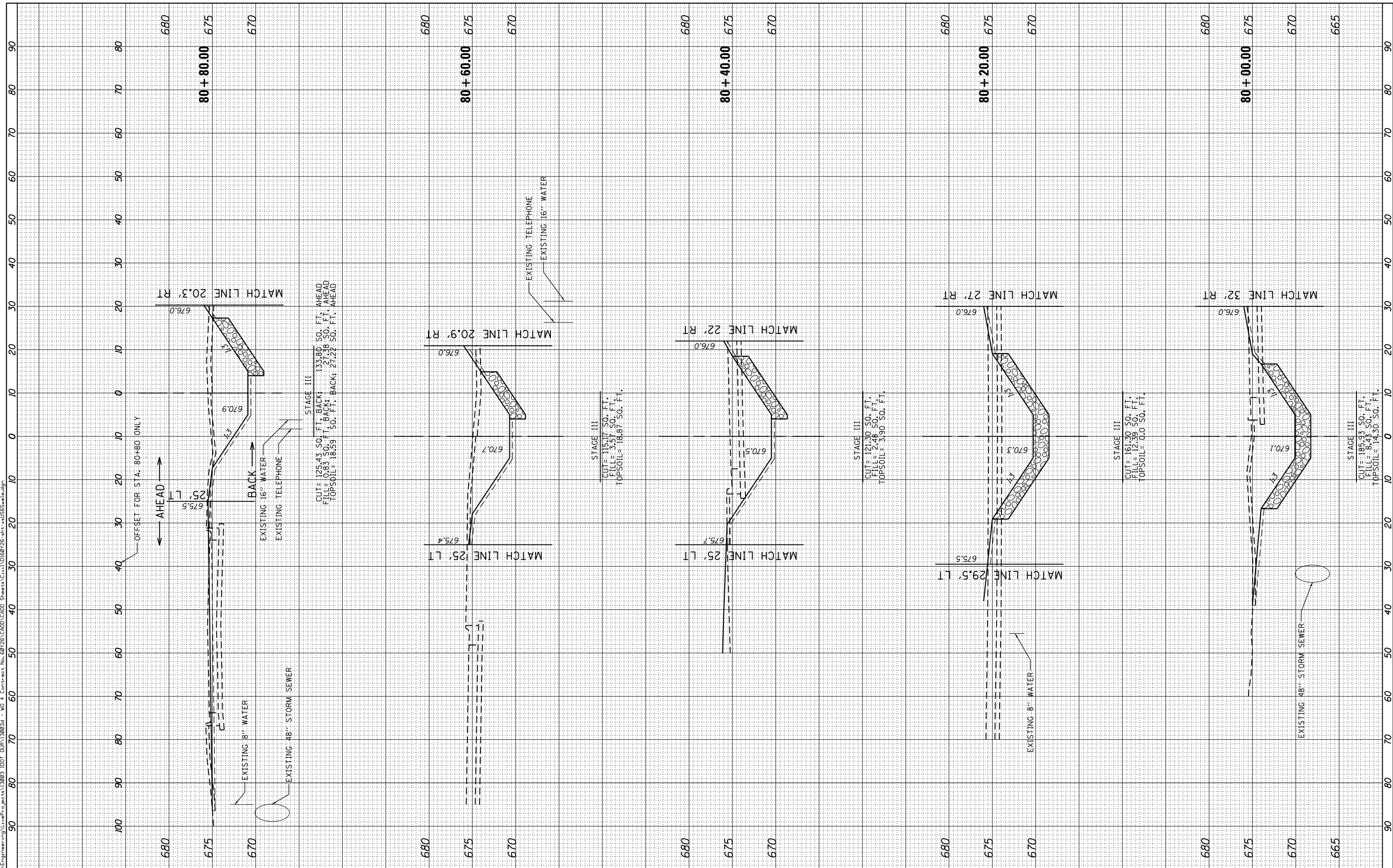

USER NAME = johnn	DESIGNED - TGM	REVISED -
PLOT SCALE = 20.0000' / in.	DRAWN - CC	REVISED -
PLOT DATE = 2/2/2018	CHECKED - JMT	REVISED -
	DATE - 10-15-2014	REVISED -

**STATE OF ILLINOIS
DEPARTMENT OF TRANSPORTATION**

CROSS SECTIONS STA. 80+00 TO STA. 80+80			
WATER QUALITY SWALE			
SCALE:	SHEET 1	OF 4 SHEETS	STA. 80+00 TO STA. 80+80

F.A. RTE.	SECTION	COUNTY	TOTAL SHEETS	SHEET NO.
0297	3178G-N(14)	COOK	151	148
CONTRACT NO. 60Y26				
ILLINOIS FED. AID PROJECT				

FINAL SURVEY	SURVEYED	BY	DATE
NOTE BOOK	PLOTTED		
AREAS CHECKED	TEMPLATE		
NO.	AREAS CHECKED		

ORIGINAL SURVEY	SURVEYED	BY	DATE
NOTE BOOK	PLOTTED		
AREAS CHECKED	TEMPLATE		
NO.	AREAS CHECKED		

FILE NAME = G:\Engineering\Irrigation\Projects\13003\DOT DURN\2023 - WD 4 - Contract No. 60Y26\CADD\CADD Sheets\Cv1\10160Y26-int-us58swale.dgn

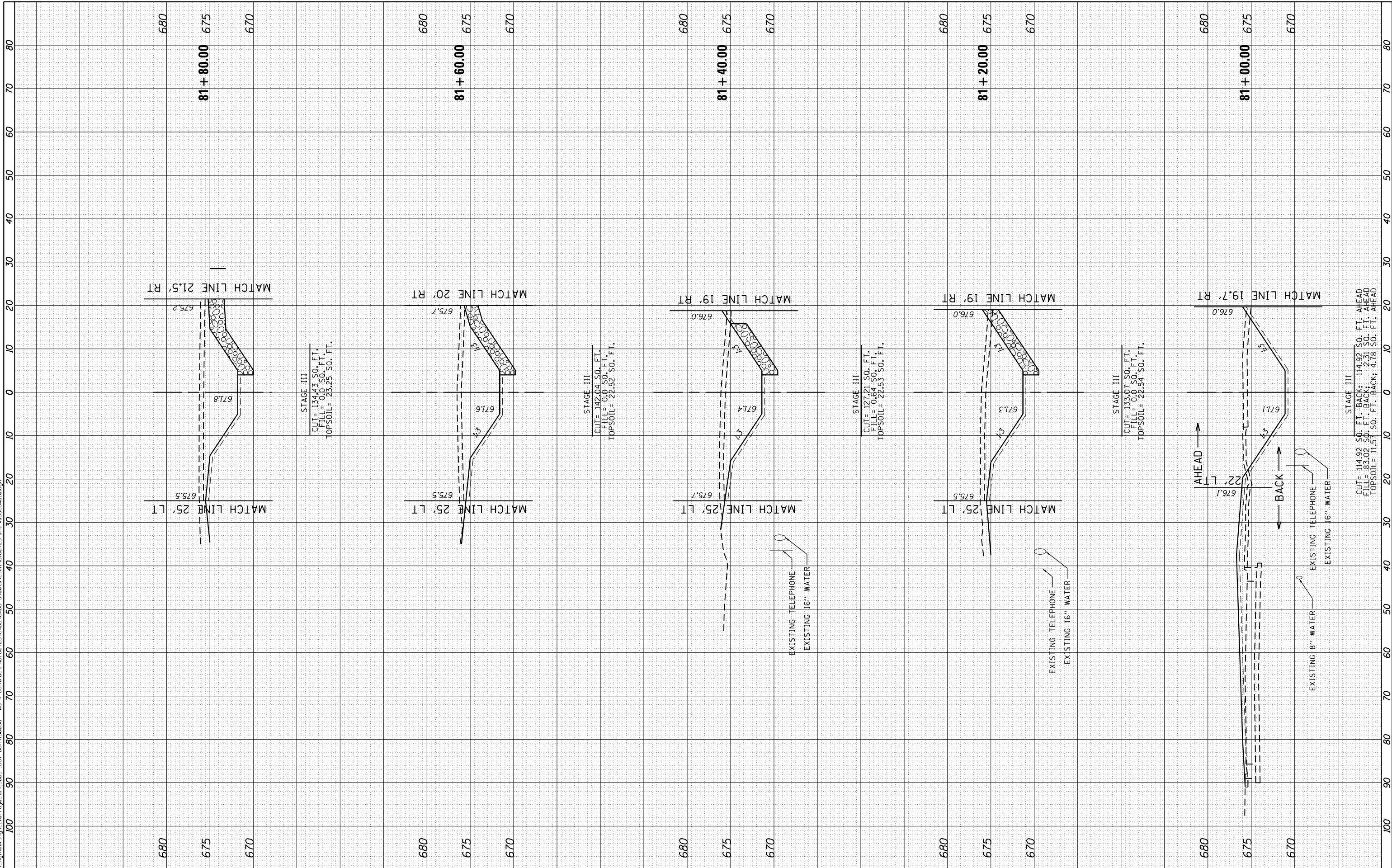

USER NAME = johnn	DESIGNED - TGM	REVISED -
PLOT SCALE = 20.0000' / in.	DRAWN - CC	REVISED -
PLOT DATE = 2/2/2018	CHECKED - JMT	REVISED -
	DATE - 10-15-2014	REVISED -

**STATE OF ILLINOIS
DEPARTMENT OF TRANSPORTATION**

CROSS SECTIONS STA. 81+00 TO STA. 81+80		
WATER QUALITY SWALE		
SCALE:	SHEET 2 OF 4 SHEETS	STA. 81+00 TO STA. 81+80

F.A. RTE.	SECTION	COUNTY	TOTAL SHEETS	SHEET NO.
0297	3178G-N(14)	COOK	151	149
CONTRACT NO. 60Y26				
ILLINOIS FED. AID PROJECT				

FINAL SURVEY NO.	SURVEYED PLOTTED TEMPLATE AREAS CHECKED	BY	DATE

ORIGINAL SURVEY NO.	SURVEYED PLOTTED TEMPLATE AREAS CHECKED	BY	DATE

FILE NAME = G:\Engineering\Live\Projects\13003\DOT DURN\20233 - WD 4 - Contract No. 60Y26\CADD\CADD Sheets\Civil\0180Y26-int-cv1585swale.dgn

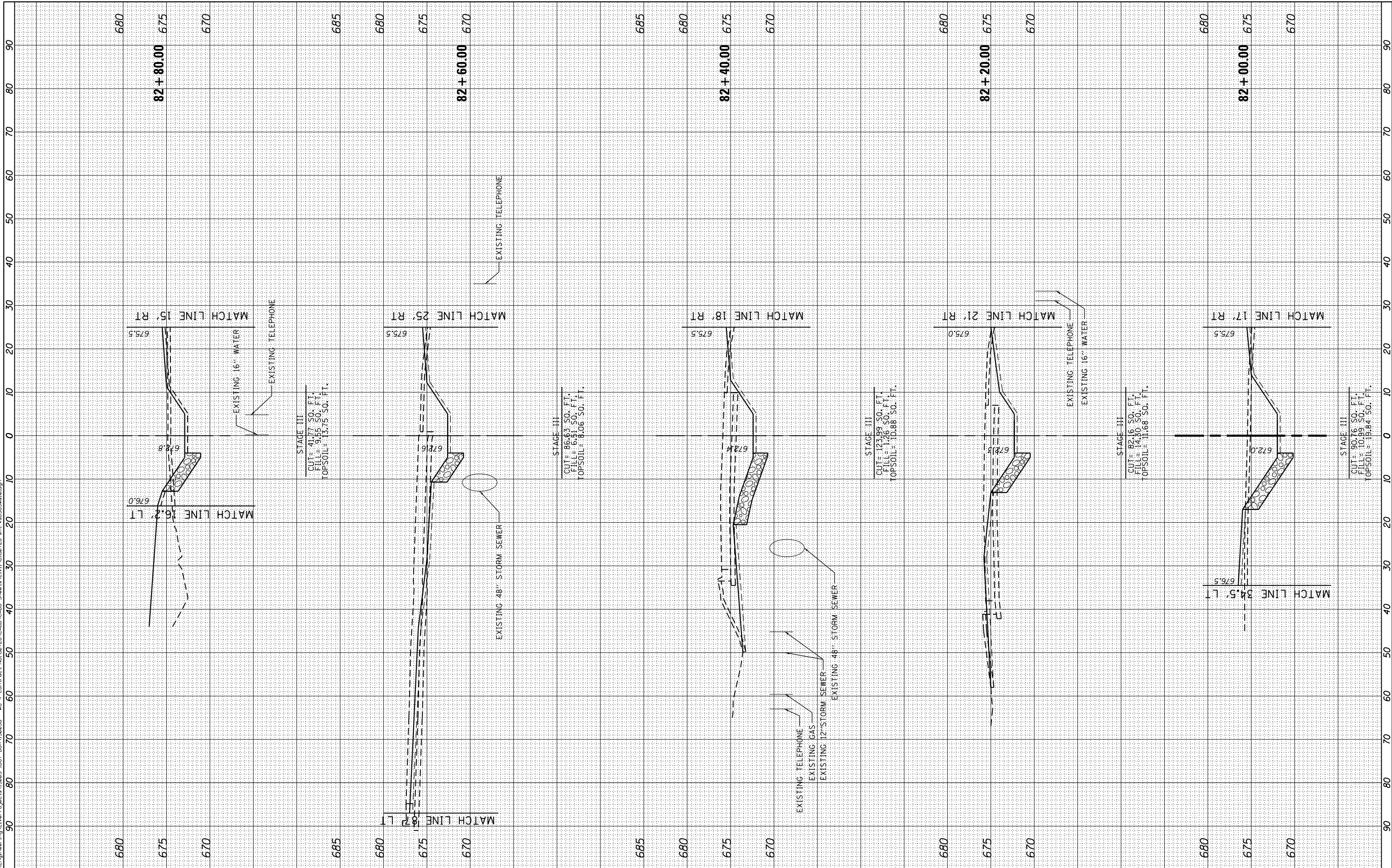

USER NAME = johnn	DESIGNED - TGM	REVISED -
PLOT SCALE = 20.0000' / in.	DRAWN - CC	REVISED -
PLOT DATE = 2/2/2018	CHECKED - JMT	REVISED -
	DATE - 10-15-2014	REVISED -

**STATE OF ILLINOIS
DEPARTMENT OF TRANSPORTATION**

CROSS SECTIONS STA. 82+00 TO STA. 82+80			
WATER QUALITY SWALE			
SCALE:	SHEET 3	OF 4 SHEETS	STA. 82+00 TO STA. 82+80

F.A. RTE.	SECTION	COUNTY	TOTAL SHEETS	SHEET NO.
0297	3178G-N(14)	COOK	151	150
CONTRACT NO. 60Y26				
ILLINOIS FED. AID PROJECT				

FINAL SURVEY NO.	SURVEYED PLOTTED AREAS CHECKED	BY	DATE
NOTE BOOK	TEMPLATE AREAS CHECKED		

ORIGINAL SURVEY NO.	SURVEYED PLOTTED AREAS CHECKED	BY	DATE

FILE NAME = G:\Engineering\Live\Projects\13003\DOT DUR\20233 - WD 4 Contract No. 60Y26\CADD\CADD Sheets\Civil\0180726-int-cv1585swale.dgn

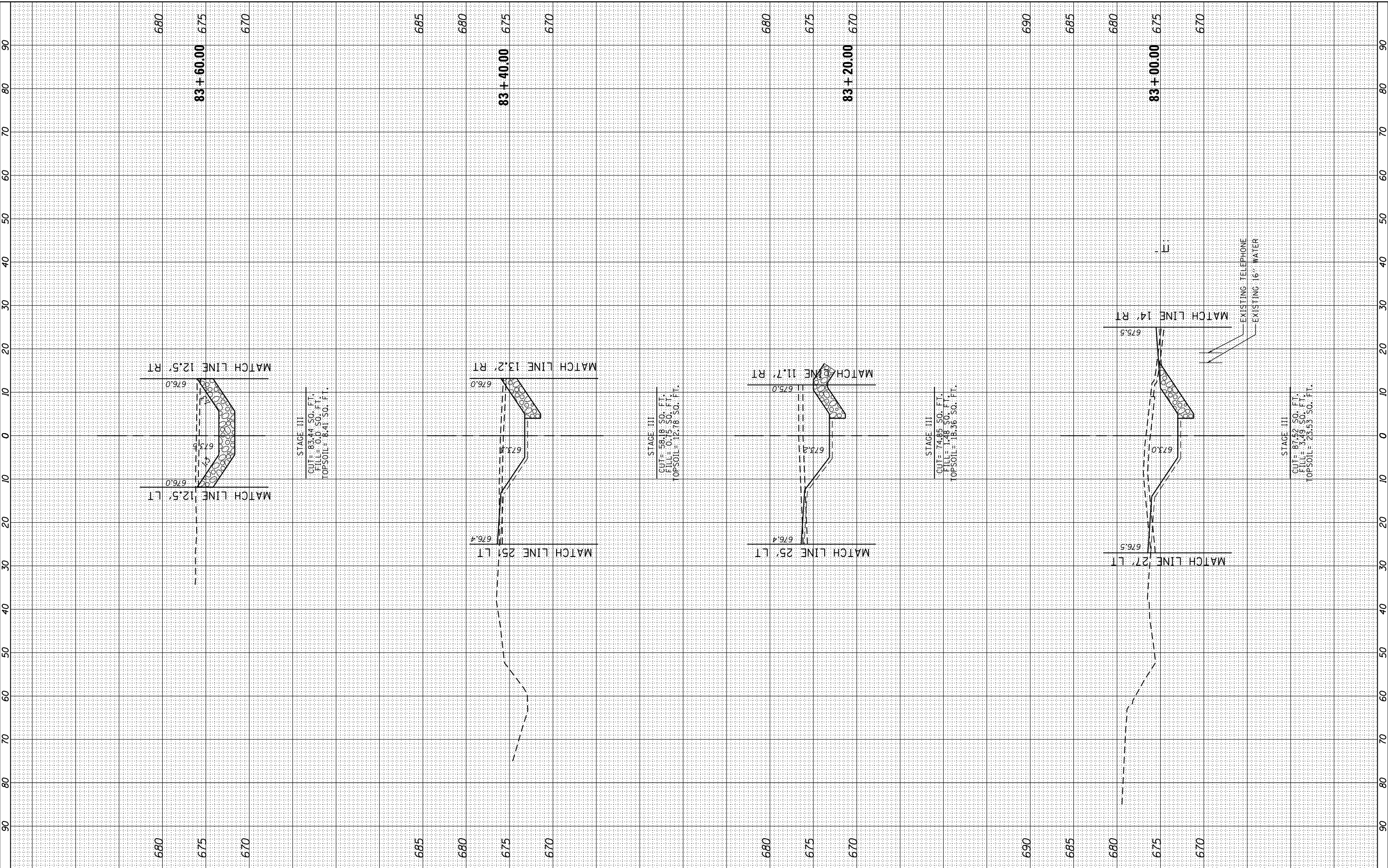

USER NAME = johnn	DESIGNED - TGM	REVISED -
PLOT SCALE = 20.0000' / in.	DRAWN - CC	REVISED -
PLOT DATE = 2/2/2018	CHECKED - JMT	REVISED -
	DATE - 10-15-2014	REVISED -

**STATE OF ILLINOIS
DEPARTMENT OF TRANSPORTATION**

**CROSS SECTIONS STA. 83+00 TO STA. 83+60
WATER QUALITY SWALE**

SCALE: SHEET 4 OF 4 SHEETS STA. 83+00 TO STA. 83+60

F.A. RTE. 0297	SECTION 3178G-N(14)	COUNTY COOK	TOTAL SHEETS 151	SHEET NO. 151
CONTRACT NO. 60Y26				
ILLINOIS FED. AID PROJECT				