

- I-64 TYPICAL SECTION NOTES:**
- FOR HMA SURFACE REMOVAL, VARIABLE DEPTH, THE CONTRACTOR SHALL REMOVE EXISTING HMA OVERLAY TO THE TOP OF EXISTING PCC PAVEMENT. SEE HMA SURFACE REMOVAL TABLES FOR REFERENCE.
 - FOR HMA OVERLAY THICKNESS, SEE HMA OVERLAY TABLES FOR REFERENCE.
 - SEE REMOVAL PLANS FOR EXISTING PAVEMENT CORE INFORMATION.
 - WHEN THE SUPERELEVATION RATE OF THE PAVEMENT IS BETWEEN 0% AND 4% THE SHOULDER SHALL BE SLOPED AT 4%. WHEN THE SUPERELEVATION RATE OF THE PAVEMENT EXCEEDS 4% THE SHOULDER SHALL BE SLOPED SO THAT THE ALGEBRAIC DIFFERENCE BETWEEN PAVEMENT AND SHOULDER SLOPES WILL NOT BE GREATER THAN 8%.

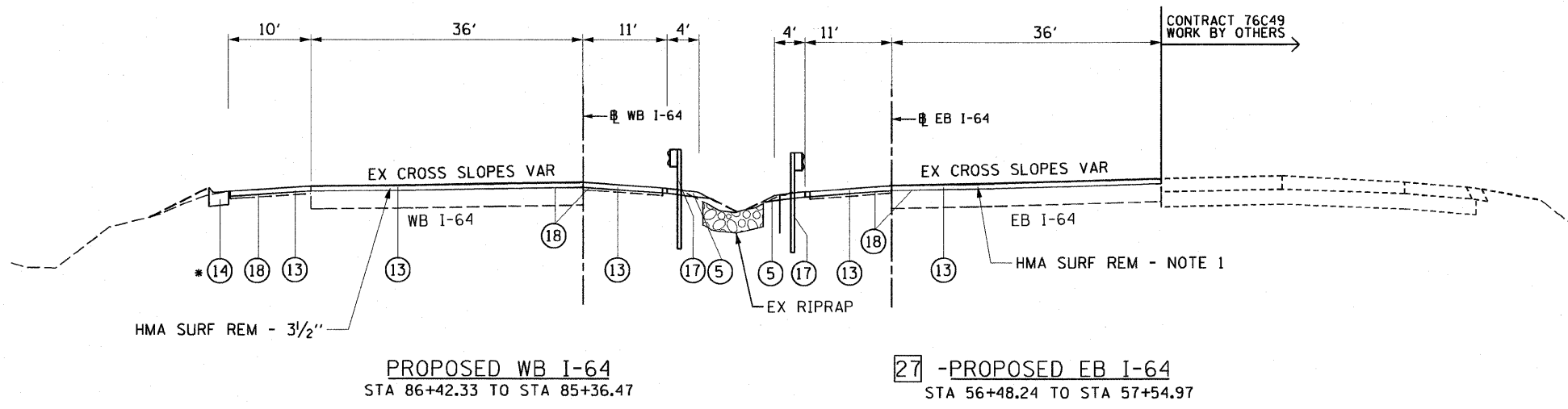

- I-64 PROPOSED LEGEND:**
- PORTLAND CEMENT CONCRETE PAVEMENT
 - (1A) - 10 1/2" (JOINTED) (RAMPS)
 - (1B) - 12 1/2" (JOINTED)
 - (1C) - 14" (JOINTED)
 - AGGREGATE BASE COURSE, TYPE A - 12"
 - CONCRETE GUTTER, TYPE A
 - PORTLAND CEMENT CONCRETE SHOULDERS
 - (4A) - 10"
 - (4B) - 10 1/2"
 - (4C) - 12 1/2"
 - (4D) - 14"
 - AGGREGATE SHLDS, TYPE B - SEE PLANS FOR THICKNESS
 - *#6 TIE BARS, 30" LONG AT 30" C-C (IF LONGITUDINAL SAWED JOINT) / #6 TIE BARS, 24" LONG AT 24" C-C (IF LONGITUDINAL CONSTRUCTION JOINT) (INCLUDED IN PRICE FOR BID FOR VARIOUS PCC ITEMS)
 - *#6 TIE BARS, 24" LONG AT 24" C-C (INCLUDED IN PRICE FOR BID FOR VARIOUS PCC ITEMS)
 - PIPE UNDERDRAINS - 6"
 - CONCRETE BARRIER SINGLE FACE, 42 INCH HEIGHT (SPECIAL)
 - COMB CONCRETE CURB AND GUTTER, TYPE B-6.24 (MODIFIED)
 - SEEDING AND MULCHING (BY OTHERS)
 - NOT USED
 - HMA OVERLAY - NOTE 2
 - COMB CONCRETE CURB AND GUTTER, TYPE B-6.24
 - STONE RIPRAP, CLASS A4
 - CONCRETE BARRIER DOUBLE FACE, 42 INCH HEIGHT
 - STEEL PLATE BEAM GUARDRAIL TYPE A, 6 FOOT POSTS
 - BITUMINOUS MATERIALS (PRIME COAT)
 - CONTINUOUSLY REINFORCED PCC PAVEMENT - 12 1/2"
 - CONTINUOUSLY REINFORCED PCC PAVEMENT - 14"
 - STABILIZED SUBBASE - HOT-MIX ASPHALT, 4"

* COMB CONCRETE CURB AND GUTTER, TYPE B-6.24 ENDS AT STA 86+42.45

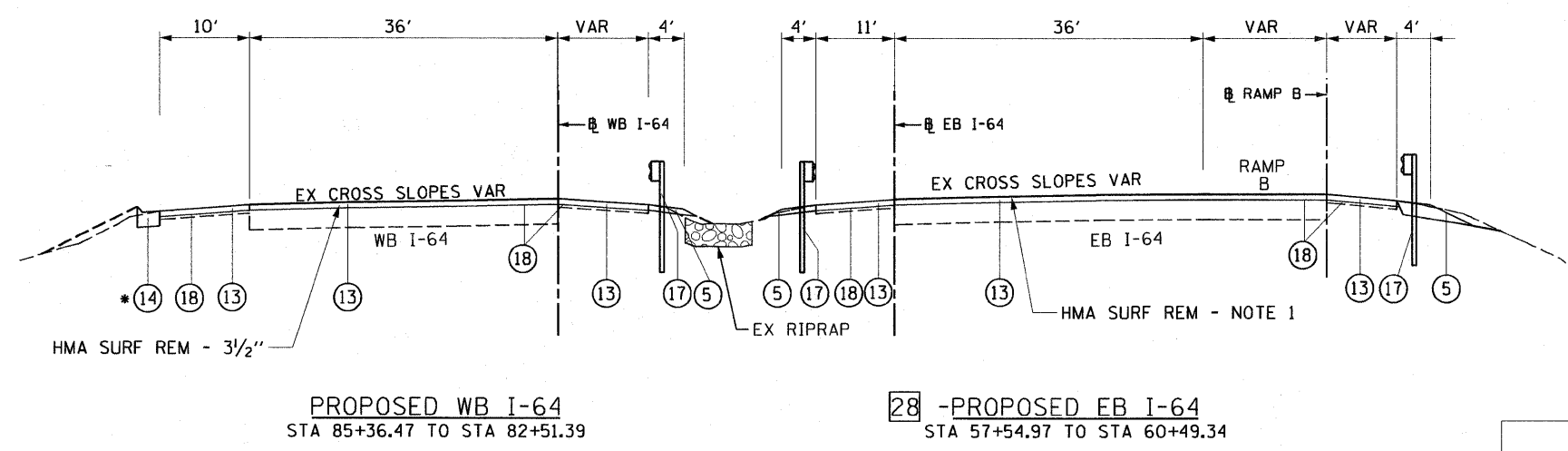

* COMB CONCRETE CURB AND GUTTER, TYPE B-6.24 BEGINS AT STA 82+73.28

HOT-MIX ASPHALT MIXTURE REQUIREMENTS

MIXTURE TYPE	AC TYPE	AIR VOIDS
POLYMERIZED HOT-MIX ASPHALT SURFACE COURSE, SMA, N80	SBS 76-22	4% @ 80 Gyr
POLYMERIZED HOT-MIX ASPHALT BINDER COURSE, SMA, N80	SBS 76-22	4% @ 80 Gyr

THE UNIT WEIGHT USED TO CALCULATE ALL HMA SURFACE MIXTURE QUANTITIES IS 112 LBS/SQYD/IN