

DETAILS OF MAILBOX TURNOUTS

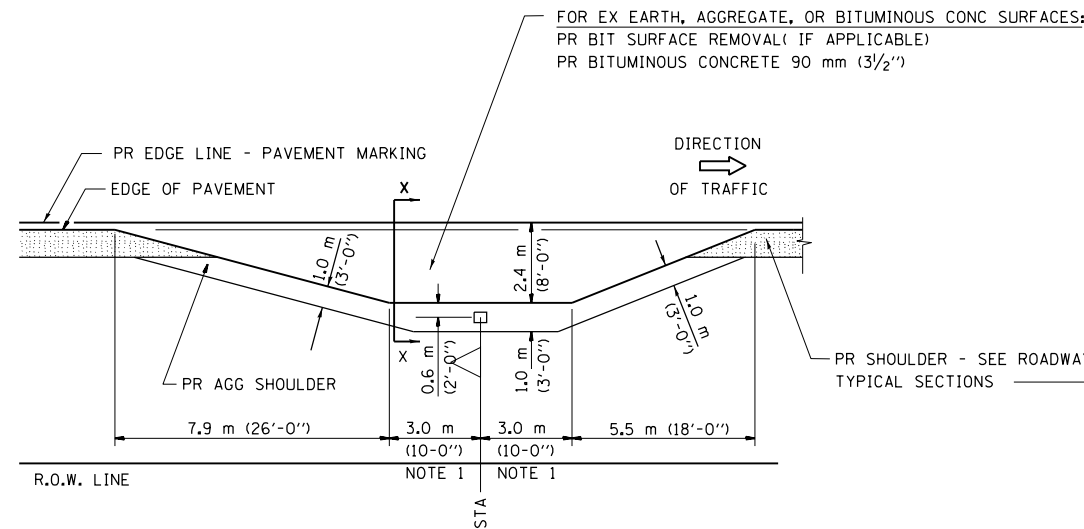

PLAN - MAILBOX TURNOUTS

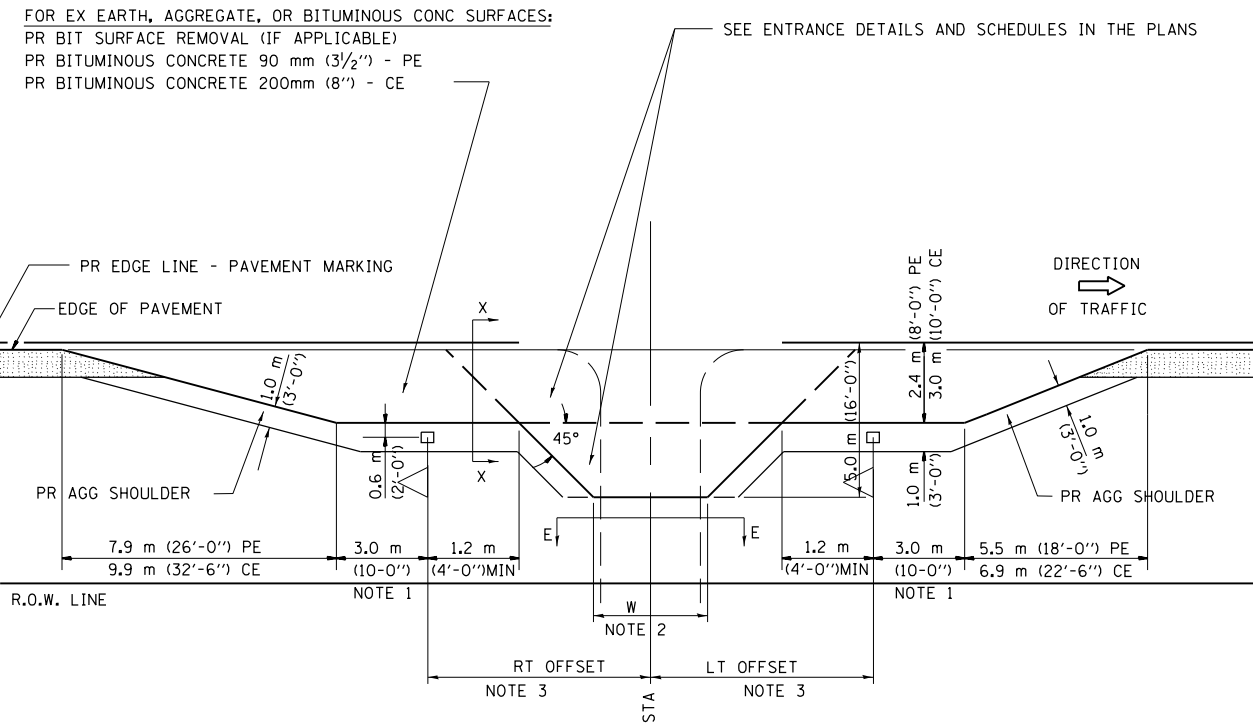

PLAN - COMBINED MAILBOX TURNOUT WITH TRAILING OR LEADING ENTRANCE

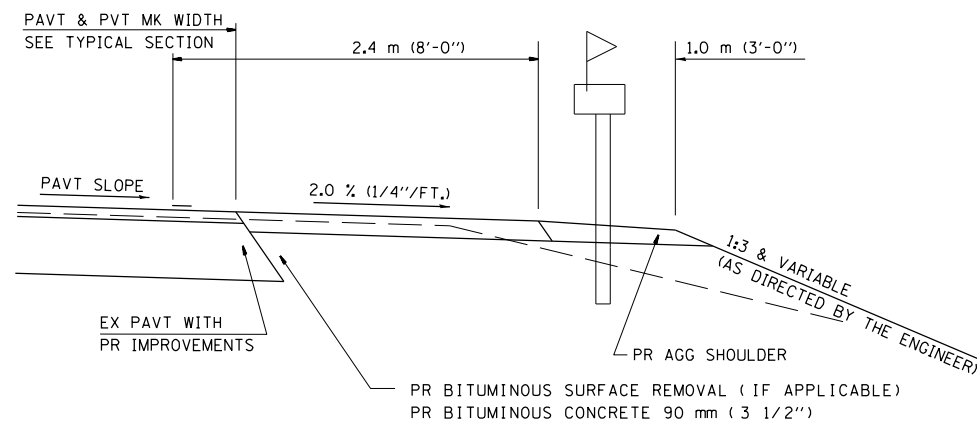

SECTION X-X THRU MAILBOX TURNOUT
ALSO APPLIES TO MAILBOX TURNOUTS COMBINED WITH
EX EARTH, AGGREGATE, OR BITUMINOUS PE & FE

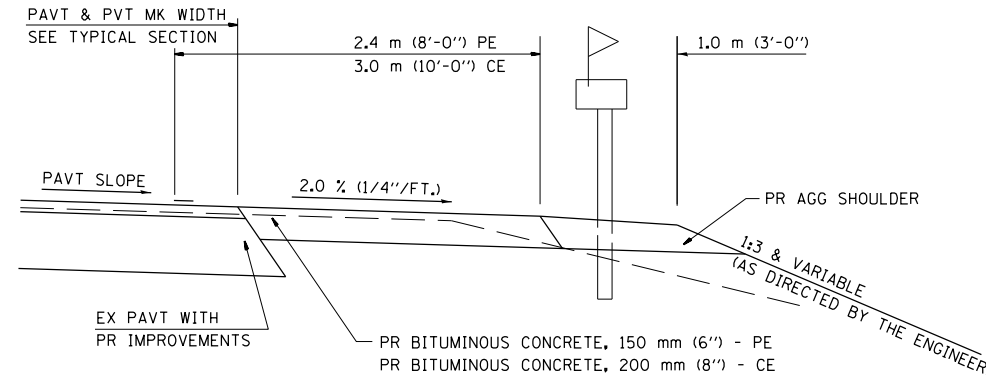

SECTION X-X THRU MAILBOX TURNOUT
COMBINED WITH EX BITUMINOUS CONC & PC CONC PE & CE

- NOTE 1 IF MORE THAN ONE MAILBOX IS PRESENT, DIMENSION FROM CENTER OF END MAILBOX.

NOTE 2 FOR ENTRANCE LAYOUT DIMENSIONS AND SECTIONS A-A & E-E REFER TO THE SCHEDULES IN THE PLANS.

NOTE 3 BOTH LT OR RT OFFSETS FOR MAILBOX SHOWN USE OFFSET DIMENSION PER SCHEDULE AND REFER TO LAYOUT SHOWN ON THE PLAN.

ALL DIMENSIONS ARE IN MILLIMETERS (INCHES)
UNLESS OTHERWISE SHOWN.

FILE NAME =	USER NAME = sparksgw	DESIGNED -	REVISED -	STATE OF ILLINOIS DEPARTMENT OF TRANSPORTATION	PPP RURAL/URBAN ENTRANCE & MAILBOX DETAIL W/O CONC. GUTTER	F.A.P. RTE.	SECTION	COUNTY	TOTAL SHEETS	SHEET NO.	
		DRAWN -	REVISED -			514	106RS-6	HANCOCK	26	25	
		CHECKED -	REVISED -			CONTRACT NO. 72C92					
		DATE -	REVISED -			ILLINOIS FED. AID PROJECT					
PLOT SCALE = 40.0000' / in. PLOT DATE = Feb-07-2012 01:52:24PM				SCALE: 20		SHEET NO. 2 OF 3 SHEETS		STA.		TO STA.	