

F.A.U. RTE.	SECTION	COUNTY	TOTAL SHEETS	SHEET NO.
8419	99-00048-01-PV	FAYETTE	142	26
STA.		TO STA.		
FED. ROAD DIST. NO.	ILLINOIS	FED. AID PROJECT		
CONTRACT NO. 95500				

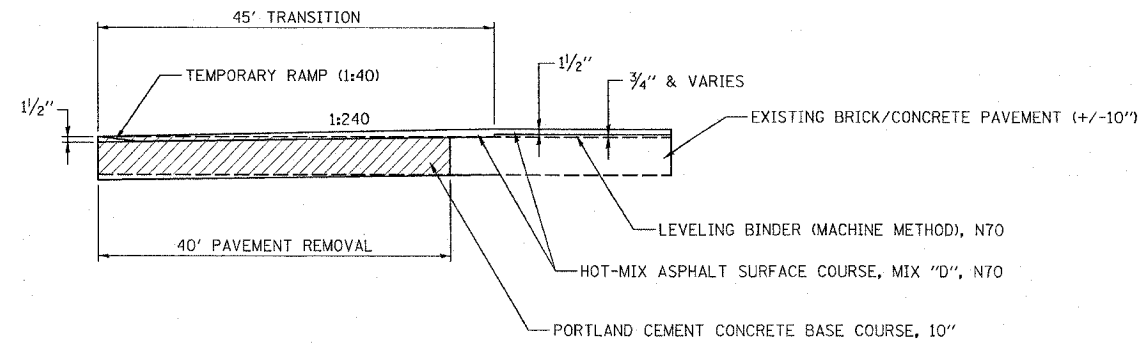

**TRANSITION DETAIL**

(GALLATIN STREET)  
STA 98+69 TO STA 99+14

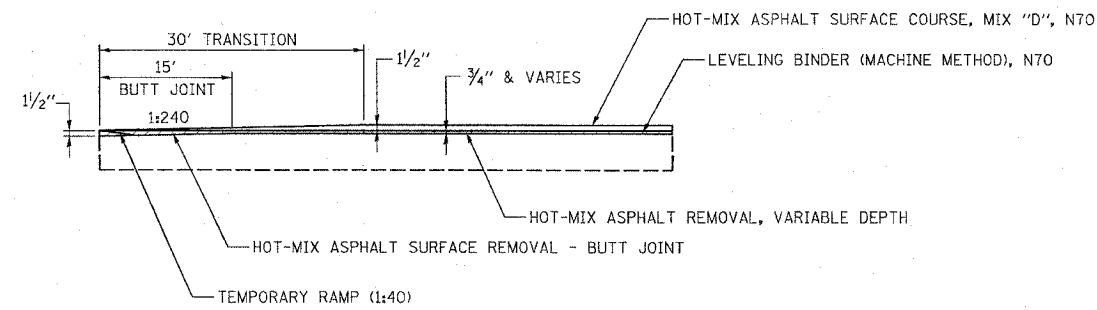

**BUTT JOINT DETAIL**

(GALLATIN STREET)  
STA 18+13.5 TO STA 18+28.5

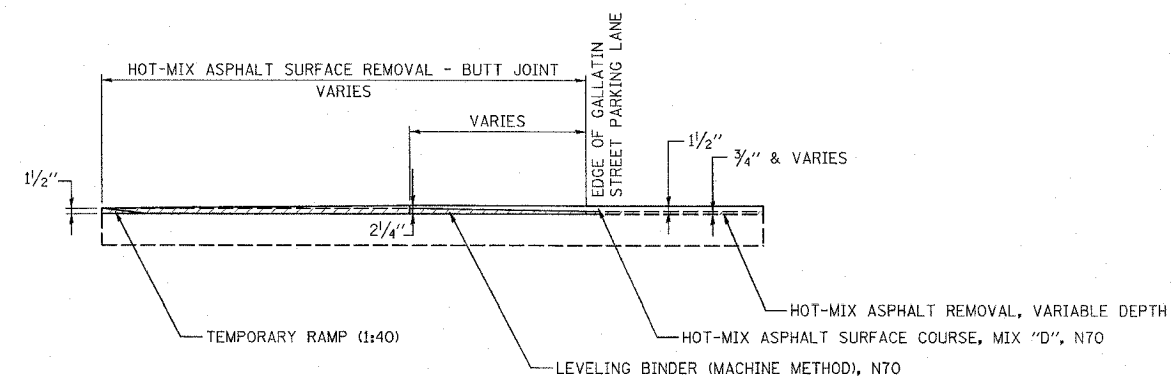

**BUTT JOINT DETAIL**

(SIDE STREETS)

SEVENTH STREET: STA 703+70 TO STA 704+26  
STA 704+67 TO STA 704+87

SIXTH STREET: STA 604+68 TO STA 605+32

FIFTH STREET: STA 503+72 TO STA 504+14  
STA 504+67 TO STA 504+98

FOURTH STREET: STA 403+85 TO STA 404+14  
STA 404+68 TO STA 404+98

REVISIONS	
NAME	DATE

ILLINOIS DEPARTMENT OF TRANSPORTATION

**JOINT DETAILS**

SCALE: VERT.  
HORIZ.  
DATE

DRAWN BY KOJ  
CHECKED BY BWC

CAAD FILE: 14812/011\_joints.dgn  
PLOTED: 3/5/2007

H.M. & G. NO. 4812