



Illinois Department of Transportation

Office of Intermodal Project Implementation / Division of Aeronautics
1 Langhorne Bond Drive / Springfield, Illinois 62707-8415

April 18, 2024

SUBJECT: MidAmerica St. Louis Airport
Mascoutah, Illinois
St. Clair County
Illinois Project Number: BLV-5101
AIP Project Number: 3-17-0146-TBD
Contract No. SC071
Item No. 02A, April 26, 2024 Letting
Addendum A

NOTICE TO PROSPECTIVE BIDDERS

Attached is an addendum to the plans or proposal. This addendum involves revised and/or added material.

Reason for Addendum:

Revisions to the Plans, Specifications and Schedule of Prices

To All Plan Holders:

The following changes to the bid documents dated March 1, 2024, are included in Addendum A:

1. Add sheets to GI101
2. Add notes for new quantities and pay items to Plan Sheet GI102
3. Add notes for soil disposal area and haul route Plan Sheet GI103
4. Add existing buildings and labels on Plan Sheet GI104
5. Add notes on Plan Sheet GC001
6. Add notes and access gate on Plan Sheet GC101
7. Add notes on Plan Sheet GC102
8. Add notes on Plan Sheet GC103
9. Add notes on Plan Sheet GC104
10. Add notes on Plan Sheet GC105
11. Clean up linework on Plan Sheet LG101
12. Clean up linework on Plan Sheet LG102
13. Add detail and notes to plan sheet CD101
14. Clean up linework on Plan Sheet CS101
15. Clean up linework on Plan Sheet CI101
16. Clean up linework on Plan Sheet CP101
17. Add earthwork table to Sheet CG101
18. Clean up linework on Plan Sheet CG102
19. Clean up linework on Plan Sheet CG103
20. Add marking to Plan Sheet CM103
21. Add notes on Plan Sheet CM501
22. Add detail on Plan Sheet CM502
23. Add notes and cleanup linework on Plan Sheet EL101
24. Add notes, cleanup linework and move apron light location on Plan Sheet EL102
25. Modify base mounted light detail on Plan Sheet EL501
26. Add notes to concrete encased duct detail on Plan Sheet EL502
27. Add Sheets EL507-EL508 for Glycol Lift Station Control Panel

28. Clarify Item C-105 Mobilization, Section 105-5.2 Measurement and Payment
29. Clarify Item C-105 Mobilization, Section 105-6 Basis of Payment
30. Add Specifications SP-11 and SP-12 to Technical Specification Table of Contents
31. Clarify Item SP-5 Power Distribution, Section 1-2.2 Service Entrance
32. Modify and add language in Item SP-8 Valve & Actuators, Section 8-2.9 Remote Position/Actuator Status Indication, Part A
33. Clarify Item SP-9 BLV Badging Requirements, Section IX
34. Add Item SP-11 Repair Haul Route #2

Plan Changes:

- Sheet GI101
 - Updated to add sheets 59A and 59B to the Index
- Sheet GI102
 - Updated to add pay items AW801995 and update quantities for AW152410, AW620520 and AW 620525
- Sheet GI103
 - Updated to add note for incidental haul route radius, soil disposal area and soil disposal access.
- Sheet GI104
 - Updated to add existing buildings and linework for safety areas.
- Sheet GC001
 - Updated to add notes regarding lead times on materials that may be in excess of overall calendar days
- Sheet GC101
 - Updated to add note for incidental haul route radius, temporary access gate, soil disposal area and soil disposal access.
- Sheet GC102
 - Updated to add note for incidental haul route radius, temporary access gate, soil disposal area and soil disposal access.
- Sheet GC103
 - Updated to edit/clarify call-offs and dimensions for phasing area.
- Sheet GC104
 - Updated to delete unnecessary linework and show temporary fencing from Phase 1
- Sheet GC105
 - Updated to delete unnecessary linework
- Sheet LG101
 - Updated to cleanup and delete unnecessary linework
- Sheet LG102
 - Updated to cleanup and delete unnecessary linework
- Sheet CD101
 - Updated to add existing features, remove unnecessary linework and clarify symbols on sheet
- Sheet CS101
 - Updated to cleanup linework
- Sheet CI101
 - Updated to cleanup and delete unnecessary linework
- Sheet CP101
 - Updated to cleanup and delete unnecessary linework
- Sheet CG101
 - Updated to add earthwork calculation table
- Sheet CG102
 - Updated to update linework
- Sheet CG103
 - Updated to update linework
- Sheet CM103
 - Updated to extend taxiway centerline

- Sheet CM501
 - Updated to add note for space numbers to Fuel Truck Parking Space Marking detail
- Sheet CM502
 - Updated to add detail for Service Road Yield Sign Support Detail
- Sheet EL101
 - Updated to cleanup linework
- Sheet EL102
 - Updated to cleanup linework and move location of light pole.
- Sheet EL501
 - Updated to add clarify Base Mounted Medium Intensity Light Detail
- Sheet EL502
 - Updated to add dimensions to Concrete Encased Duct Bank details for depth from surface
- Sheet EL507
 - Added for the addition of the Glycol Lift Station Control Panel
- Sheet EL508
 - Added for the addition of the Glycol Lift Station Control Panel

Specification Changes:

- Technical Specifications Table of Contents, PART 14 – SPECIAL PROVISIONS
 - ADD Item SP-11 Repair Haul Route #2
 - ADD Item SP-12 Glycol Control Panel
 - ADD Item SP-13 General Electrical Requirements
- Item C-105 MOBILIZATION, METHOD OF MEASUREMENT, Section 105-5.2 Mobilization basis of measurement and payment.
 - ADD the following after the last sentence: “Re-mobilization due to suspension of calendar days will not be paid for.”
- Item C-105 MOBILIZATION, BASIS OF PAYMENT, Section 105-6 Payment.
 - ADD the following after the first sentence: “Re-mobilization due to suspension of calendar days will not be paid for.”
- Item SP-5 Power Distribution, Section 1-2.2 Service Entrance
 - DELETE: “COSTS FROM SERVING UTILITY THAT MAY BE CHARGED FOR PROVIDING NEW PERMANENT ELECTRICAL SERVICE TO THE FACILITY WILL BE PAID BY THE OWNER. CONTRACTOR SHOULD NOT INCLUDE THSE IN HIS BASE-BID COST.”
- Item SP-8 Valves & Actuators, Section 8-2.9 Remote Position/Actuator Status Indication, Part A
 - MODIFY 1000 feet to approximately 1,200 feet
 - ADD the following after the last sentence: “If the manufacturer’s standard remote hand station is not capable of functioning over the required distance from the actuator, the remote hand station shall be equipped with an extended range option, or a standard pushbutton station consisting of open/close/stop pushbuttons and indicator lights shall be provided. Documentation indicating the suitability of the remote hand station for installations over the required distances shall be provided with the shop drawings.”
- Item SP-9 BLV Badge Requirements
 - ADD the following Section after Section VIII:
 - “IX. BASIS OF PAYMENT
 - A. Payment will not be made for BLV Bading Requirements. Costs associated with BLV Bading Requirements shall be considered incidental to the project.”

- Item SP-11 Repair Haul Route #2
 - ADD this specification to the project.
- Item SP-12 Glycol Control Panel
 - ADD this specification to the project.
- Item SP-13 General Electrical Requirements
 - ADD this specification to the project.

Schedule of Prices Changes:

- Modify quantity for pay item AW152410 UNCLASSIFIED EXCAVATION
- Modify quantity for pay item AW620520 PAVEMENT MARKING-WATERBORNE
- Modify quantity for pay item AW620525 PAVEMENT MARKING-BLACK BORDER
- Add pay item AW801995 REPAIR HAUL ROUTE #2 – per TON
- Add pay item AX801461 GLYCOL LIGHT STATION CONTROL PANEL – per L SUM

Prime contractors must utilize the enclosed material when preparing their bid and must include any changes to the Schedule of Prices in their bid.

Questions on this addendum may be directed to Tom Morris of CMT at 314-571-9080 or by email tmorris@cmtengr.com.

Attachments

- Revised Plan Sheet GI101-104, GC001, GC101-105, LG101-102, CD101, CS101, CI101, CP101, CG101-103, CM103, CM501-502, EL101-102, EL501-502, EL-507-508
- Revised Specification C-105
- Revised Specification SP-5
- Revised Specification SP-8
- Revised Specification SP-9
- Specification SP-11 Repair Haul Route #2
- Specification SP-12 Glycol Control Panel
- Specification SP-13 General Electrical Requirements

ADDENDUM A PLAN SHEET REVISIONS

100% SUBMITTAL
MARCH 1, 2024

TERMINAL APRON EXPANSION



MIDAMERICA
ST. LOUIS AIRPORT
ST. CLAIR COUNTY, IL

4/12/2024 ADDENDUM A

MARK	DATE	DESCRIPTION

BLV PROJECT NO. 2024-04

IL PROJECT NO. BLV-5101

CMT PROJECT NO: 22001186.00

CAD DWG FILE: 22001186 - G1100.DWG

DESIGNED BY: CMT

DRAWN BY: CMT

CHECKED BY: CMT

APPROVED BY: CMT

COPYRIGHT: CRAWFORD, MURPHY & TILLY, INC. 2021

SHEET TITLE

SHEET INDEX



SHEET SET INDEX		
SHEET NUMBER	SHEET INDEX	SHEET TITLE
1	GH100	COVER SHEET
2	GH101	SHEET INDEX
3	GH102	SUMMARY OF QUANTITIES
4	GH103	SITE PLAN
5	GH104	ILS CRITICAL AREAS
6	GC001	CONSTRUCTION ACTIVITY PLAN NOTES 1
7	GC002	CONSTRUCTION ACTIVITY PLAN NOTES 2
8	GC101	CONSTRUCTION ACTIVITY PLAN - OVERVIEW
9	GC102	CONSTRUCTION ACTIVITY PLAN - PHASE 1
10	GC103	CONSTRUCTION ACTIVITY PLAN - PHASE 1A
11	GC104	CONSTRUCTION ACTIVITY PLAN - PHASE 2
12	GC105	TEMPORARY FENCING PLAN
13	GC501	CAP DETAILS
14	GC502	TEMPORARY FENCING DETAILS 1
15	GC503	TEMPORARY FENCING DETAILS 2
16	GC504	FINAL FENCING DETAILS
17	LG101	EROSION CONTROL PLAN 1
18	LG102	EROSION CONTROL PLAN 2
19	LG501	EROSION CONTROL DETAILS
20	CD101	EXISTING CONDITIONS AND REMOVALS
21	CS101	PROPOSED IMPROVEMENTS
22	CH101	SERVICE ROAD PLAN & PROFILE SHEET
23	CI501	TYPICAL SECTIONS
24	CP101	JOINTING PLAN
25	CP501	JOINTING DETAILS
26	CP801	STAKING PLAN 1
27	CP802	STAKING PLAN 2
28	CG101	GRADING & DRAINAGE PLAN 1
29	CG102	GRADING & DRAINAGE PLAN 2
30	CG103	GLYCOL IMPROVEMENTS
31	CG201	DETENTION BASIN SB-169 IMPROVEMENT PLAN
32	CG301	UNDERDRAIN PROFILE 1
33	CG302	UNDERDRAIN PROFILE 2
34	CG303	UNDERDRAIN PROFILE 3
35	CG304	UNDERDRAIN PROFILE 4
36	CG305	UNDERDRAIN PROFILE 5
37	CG306	UNDERDRAIN PROFILE 6
38	CG307	UNDERDRAIN PROFILE 7
39	CG501	DRAINAGE DETAILS 1
40	CG502	DRAINAGE DETAILS 2
41	CG503	DRAINAGE DETAILS 3
42	CG504	DRAINAGE DETAILS 4
43	CG505	DRAINAGE DETAILS 5
44	CG506	DRAINAGE DETAILS 6
45	CG507	TRANCH DRAIN DETAILS
46	CG508	GLYCOL COLLECTION DETAILS
47	CM101	APRON MARKING REMOVAL PLAN
48	CM102	APRON MARKING PLAN 1
49	CM103	APRON MARKING PLAN 2
50	CM501	APRON PAVEMENT MARKING DETAILS
51	CM502	PAVEMENT MARKING & SIGNAGE DETAILS
52	EL101	PROPOSED ELECTRICAL LAYOUT & LIGHTING
53	EL102	ENHANCED ELECTRICAL LAYOUT PLAN
54	EL501	ELECTRICAL DETAILS 1
55	EL502	ELECTRICAL DETAILS 2
56	EL503	ELECTRICAL DETAILS 3
57	EL504	ELECTRICAL DETAILS 4
58	EL505	ELECTRICAL DETAILS 5
59	EL506	ELECTRICAL DETAILS 6
59A	EL507	ELECTRICAL DETAILS 7
59B	EL508	ELECTRICAL DETAILS 8
60	CG700	CROSS SECTION INDEX
61	CG701	APRON EXPANSION CROSS SECTIONS 1
62	CG702	APRON EXPANSION CROSS SECTIONS 2
63	CG703	APRON EXPANSION CROSS SECTIONS 3
64	CG704	APRON EXPANSION CROSS SECTIONS 4
65	CG705	APRON EXPANSION CROSS SECTIONS 5
66	CG706	APRON EXPANSION CROSS SECTIONS 6
67	CG707	APRON EXPANSION CROSS SECTIONS 7
68	CG708	APRON EXPANSION CROSS SECTIONS 8

100% SUBMITTAL
MARCH 1, 2024

TERMINAL APRON EXPANSION



MIDAMERICA
ST. LOUIS AIRPORT
ST. CLAIR COUNTY, IL

11/2/2024 ADDENDUM A

MARK | DATE | DESCRIPTION

BLV PROJECT NO. 2024-04
IL PROJECT NO. BLV-5101
CMT PROJECT NO: 22001186.00
CAD DWG FILE: 22001186 - G1100.DWG
DESIGNED BY: CMT
DRAWN BY: CMT
CHECKED BY: CMT
APPROVED BY: CMT
COPYRIGHT: CRAWFORD, MURPHY & TILLY, INC. 2021

SHEET TITLE

SUMMARY OF
QUANTITIES

SUMMARY OF QUANTITIES
BASE BID - TERMINAL APRON EXPANSION - PROJECT 1

ITEM #	DESCRIPTION	UNIT	NORTH EXPANSION QUANTITY	SOUTH EXPANSION QUANTITY	TOTAL PROJECT QUANTITY
AW108040	#4/0 XLP-JUSE CABLE	FOOT	200.0	0.0	200.0
AW108086	#6 XLP-JUSE CABLE	FOOT	4,000.0	0.0	4,000.0
AW108090	#10 XLP-JUSE CABLE	FOOT	5,000.0	5,500.0	10,500.0
AW108092	#12 XLP-JUSE CABLE	FOOT	5,500.0	0.0	5,500.0
AW108108	1/2 #6 5 KV UG CABLE	FOOT	350.0	270.0	620.0
AW108706	1/2 #6 COUNTERPOISE	FOOT	175.0	270.0	445.0
AW108960	REMOVE CABLE	FOOT	710.0	0.0	710.0
AW110201	1" PVC DUCT, DIRECT BURY	FOOT	2,325.0	0.0	2,325.0
AW110202	2" PVC DUCT, DIRECT BURY	FOOT	650.0	0.0	650.0
AW110502	2-WAY CONCRETE ENCASED DUCT	FOOT	370.0	400.0	770.0
AW110610	ELECTRICAL HANDHOLE	EACH	3.0	2.0	5.0
AW125415	MTL-BASE MOUNTED	EACH	3.0	3.0	6.0
AW125902	REMOVE BASE MOUNTED LIGHT	EACH	1.0	1.0	2.0
AW150510	ENGINEER'S FIELD OFFICE	L SUM	0.5	0.5	1.0
AW150520	MOBILIZATION	L SUM	0.5	0.5	1.0
AW152410	UNCLASSIFIED EXCAVATION	CU YD		8,067.0	8,067.0
AW155540	BY-PRODUCT LIME	TON	300.0	405.0	705.0
AW155612	SOIL PROCESSING-12"	SQ YD	7,094.0	9,692.0	16,786.0
AW156510	SILT FENCE	FOOT	1,507.0	1,550.0	3,057.0
AW156511	DITCH CHECK	EACH	6.0	6.0	12.0
AW156520	INLET PROTECTION	EACH	1.0	2.0	3.0
AW156531	EROSION CONTROL BLANKET	SQ YD	2,000.0	2,000.0	4,000.0
AW161515	TEMPORARY CLASS C FENCE	FOOT	1,150.0	1,900.0	3,050.0
AW161516	TEMPORARY CLASS C FENCE WITH JERSEY BARRIER	FOOT	405.0	400.0	805.0
AW161601	TEMPORARY GATE	EACH	2.0	1.0	3.0
AW162508	CLASS E FENCE 8'	FOOT	265.0	0.0	265.0
AW209609	CRUSHED AGG. BASE COURSE - 9"	SQ YD	6,910.0	9,090.0	16,000.0
AW209611	CRUSHED AGGREGATE BASE COURSE - 11"	SQ YD	184.0	285.0	469.0
AW209706	CRUSHED AGG. SHOULDER - 6"	SQ YD	70.0	0.0	70.0
AW302611	ASPHALT TREATED PERMEABLE SUBBASE	SQ YD	6,910.0	9,090.0	16,000.0
AW302630	A TPS TEST SECTION	EACH	0.5	0.5	1.0
AW401610	BITUMINOUS SURFACE COURSE	TON	292.0	100.0	392.0
AW401900	REMOVE BITUMINOUS PAVEMENT	SQ YD	1,613.0	495.0	2,108.0
AW501509	9" PCC PAVEMENT	SQ YD	513.0	769.0	1,282.0
AW501516	16" PCC PAVEMENT	SQ YD	5,573.0	8,319.0	13,892.0
AW501530	PCC TEST BATCH	EACH	0.5	0.5	1.0
AW602510	BITUMINOUS PRIME COAT	GALLON	2,464.0	3,280.0	5,744.0
AW603510	BITUMINOUS TACK COAT	GALLON	218.0	90.0	308.0
AW620520	PAVEMENT MARKING-WATERBORNE	SQ FT	3,600.0	3,142.0	6,742.0
AW620525	PAVEMENT MARKING-BLACK BORDER	SQ FT	1,200.0	1,282.0	2,482.0
AW620900	PAVEMENT MARKING REMOVAL	SQ FT	650.0	4,800.0	5,450.0
AW701524	24" RCP, CLASS IV	FOOT	360.0	125.0	485.0
AW701536	36" RCP, CLASS IV	FOOT	185.0	401.0	586.0
AW701900	REMOVE PIPE	FOOT	74.0	120.0	194.0
AW705526	6" PERFORATED UNDERDRAIN W/SOCK	FOOT	1,087.0	1,435.0	2,522.0
AW705635	UNDERDRAIN COLLECTION STRUCTURE	EACH	4.0	7.0	11.0
AW705640	UNDERDRAIN CLEANOUT	EACH	9.0	10.0	19.0
AW751416	TYPE 1 INLET	EACH	1.0	0.0	1.0
AW751417	TYPE 2 INLET	EACH	0.0	2.0	2.0
AW752424	PRECAST REINFORCED CONC. FES 24"	EACH	2.0	5.0	7.0
AW752436	PRECAST REINFORCED CONC. FES 36"	EACH	1.0	1.0	2.0
AW752900	REMOVE END SECTION	EACH	2.0	1.0	3.0
AW754610	PAVED DITCH	FOOT	570.0	100.0	670.0
AW770508	8" SANITARY SEWER	FOOT	394.0	398.0	792.0
AW770518	18" SANITARY SEWER	FOOT	0.0	541.0	541.0
AW770704	SANITARY MANHOLE 4'	EACH	1.0	3.0	4.0
AW770900	REMOVE SANITARY SEWER	FOOT	178.0	20.0	198.0
AW801455	REMOVE 24' TEMPORARY ACCESS ROAD #1 AND STAGING AREA #2	L SUM	1.0	0.0	1.0
AW801958	REMOVE 24' TEMPORARY ACCESS ROAD #2	L SUM	0.0	1.0	1.0
AW801966	3" GRS CONDUIT	FOOT	50.0	0.0	50.0
AW801967	RECEPTACLE PEDESTAL	EACH	5.0	0.0	5.0
AW801968	STRUT FRAMING AND PEDESTAL	L SUM	1.0	0.0	1.0
AW801969	UTILITY SERVICE INSTALLATION	L SUM	1.0	0.0	1.0
AW801971	4' X 20' TRENCH DRAIN	EACH	1.0	1.0	2.0
AW801972	9" VALVE & ACTUATOR	EACH	1.0	1.0	2.0
AW801979	BASEIN SPILLWAY MODIFICATIONS	L SUM	1.0	0.0	1.0
AW801980	75KVA DISTRIBUTION TRANSFORMER, 480-208Y/120V, 3PH, 4W	EACH	1.0	0.0	1.0
AW801981	DISTRIBUTION PANEL BOARD, 200A, 480/277V, 3PH, 4W, NEMA 3R, 30C	EACH	1.0	0.0	1.0
AW801985	POWER PANEL, 200A, 208Y/120V, 3PH, 4W, NEMA 3R	EACH	1.0	0.0	1.0
AW801992	YIELD SIGN AND POST	EACH	1.0	0.0	1.0
AW801994	8" SANITARY FORCEMAIN	FOOT	178.0	0.0	178.0
AW801995	REPAIR HAUL ROUTE #2	TON	0.0	100.0	100.0
AW801996	REMOVE FENCE	FOOT	265.0	0.0	265.0
AW801998	NON-FUSIBLE SERVICE DISCONNECT, 200A, 600V, 2-POLE, NEMA 3R	EACH	1.0	0.0	1.0
AW901999	#14 XLP-JUSE CABLE	FOOT	12,100.0	5,250.0	17,350.0
AW904510	SEEDING	ACRE	4.0	4.0	8.0
AW904510	SODDING	SQ YD	350.0	405.0	755.0
AW908510	MULCHING	ACRE	4.0	4.0	8.0
AW910915	REMOVE ROADWAY SIGN	EACH	1.0	0.0	1.0

ALTERNATE 1 - TERMINAL APRON EXPANSION - PROJECT 1

ITEM #	DESCRIPTION	UNIT	NORTH EXPANSION AA QUANTITY	SOUTH EXPANSION AA QUANTITY	TOTAL AA QUANTITY
AX108088	#8 XLP-JUSE CABLE	FOOT	620.0	600.0	1,220.0
AX108090	#10 XLP-JUSE CABLE	FOOT	850.0	950.0	1,800.0
AX110201	1" PVC DUCT, DIRECT BURY	FOOT	780.0	250.0	1,030.0
AX110202	2" PVC DUCT, DIRECT BURY	FOOT	200.0	250.0	450.0
AX801461	GLYCOL LIFT STATION CONTROL PANEL	L SUM	1.0	0.0	1.0
AX801474	LIGHTING CONTROLLER IN NEMA 3R ENCLOSURE	L SUM	1.0	0.0	1.0
AX801993	60' APRON LIGHT POLE W/FIXTURES	EACH	2.0	1.0	3.0
AX801997	FIBER OPTIC CABLE	FOOT	250.0	0.0	250.0

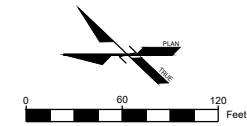

100% SUBMITTAL
MARCH 1, 2024

TERMINAL APRON EXPANSION



MIDAMERICA
ST. LOUIS AIRPORT
ST. CLAIR COUNTY, IL

▲ 4/12/2024 ADDENDUM A

MARK | DATE | DESCRIPTION

BLV PROJECT NO.	2024-04
IL PROJECT NO.	BLV-5101
CMT PROJECT NO.	22001186.00
CAD DWG FILE:	22001186 - G1100.DWG
DESIGNED BY:	CMT
DRAWN BY:	CMT
CHECKED BY:	CMT
APPROVED BY:	CMT
COPYRIGHT:	CRAWFORD, MURPHY & TILLY, INC. 2021

SHEET TITLE

SITE PLAN

SHEET 4 OF 68
G1103

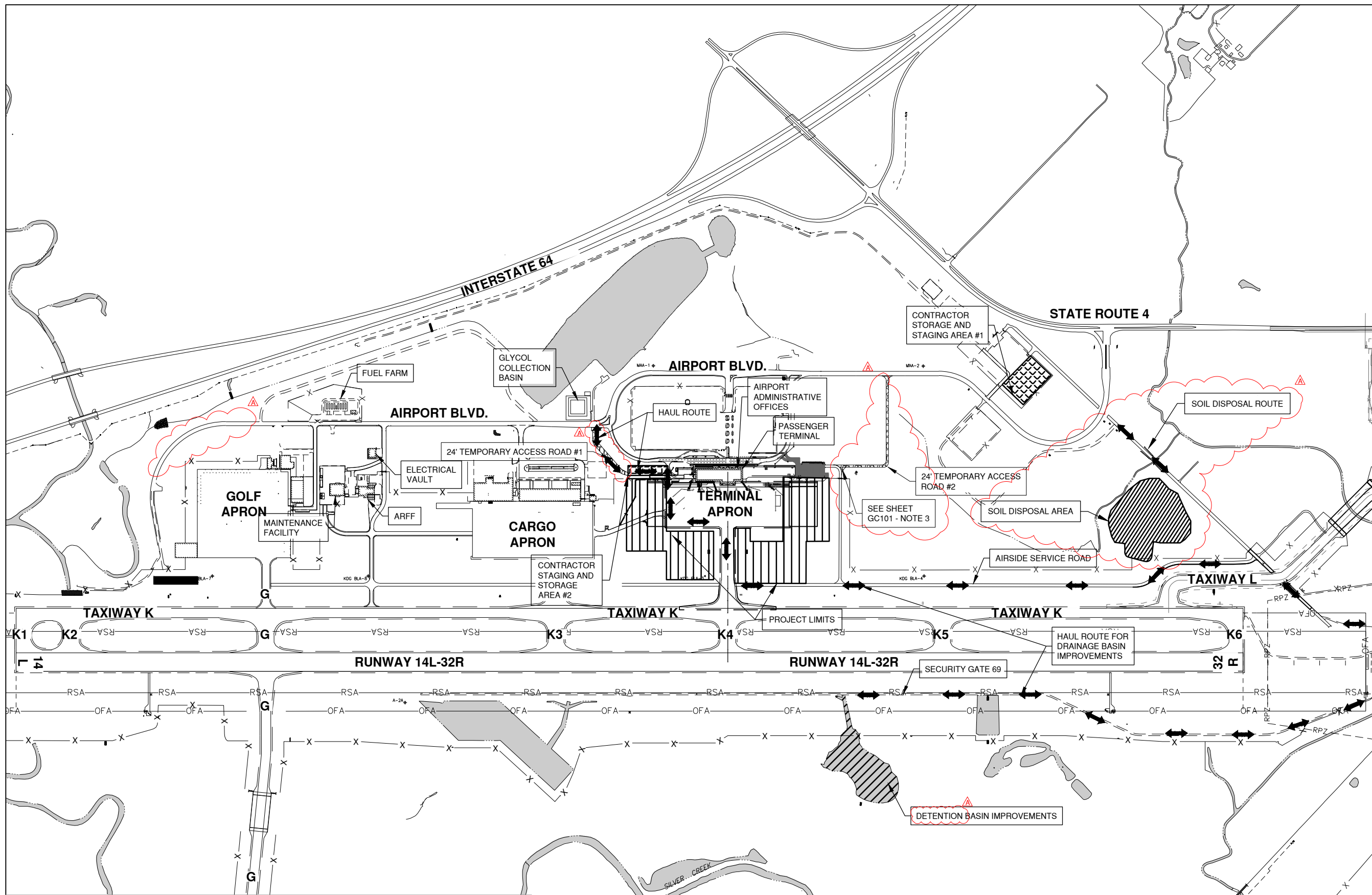

LEGEND

- PROJECT LIMITS
- CONTRACTOR'S STAGING AND STORAGE AREA
- SURVEY MONUMENT
- CONTRACTOR'S HAUL ROUTE
- EXISTING PERIMETER FENCE

MAXIMUM HEIGHT OF EQUIPMENT = 25'

SURVEY MONUMENTS

DESIGNATION	DESCRIPTION	NORTH	EAST	STATION*	OFFSET	ELEV.
A-2A	ALUM. TABLET	685705.94	2393962.24	131+70.07	330.12 RT	434.42
KDG-BLA3	ALUM. TABLET	684648.28	2396395.23	156+14.84	700.00 LT	440.04
KDG-BLA4	ALUM. TABLET	683356.50	2397627.81	174+00.33	700.00 LT	434.56
KDG-MAA-1	BRASS TABLET	686135.11	2397344.23	24+12.94	605.84 LT	443.03
KDG-BLA8	BRASS TABLET	686634.16	2394500.37	128+70.00	700.00 LT	443.54

LEGEND

- RSA — RUNWAY SAFETY AREA
- ROFA — RUNWAY OBJECT FREE AREA
- TSA — TAXIWAY SAFETY AREA
- TOFA — TAXIWAY OBJECT FREE AREA
- ▨ ILS CRITICAL AREA
- ▨ PROJECT LIMITS
- ↔ HAUL ROUTE
- SURVEY MONUMENT
- RUNWAY PROTECTION ZONE
- GLIDESLOPE CRITICAL AREA



License No. 184-000613

CONSULTANTS

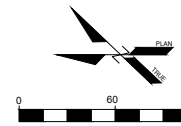

THIS BAR IS EQUAL TO 2" AT FULL SCALE (22X34)

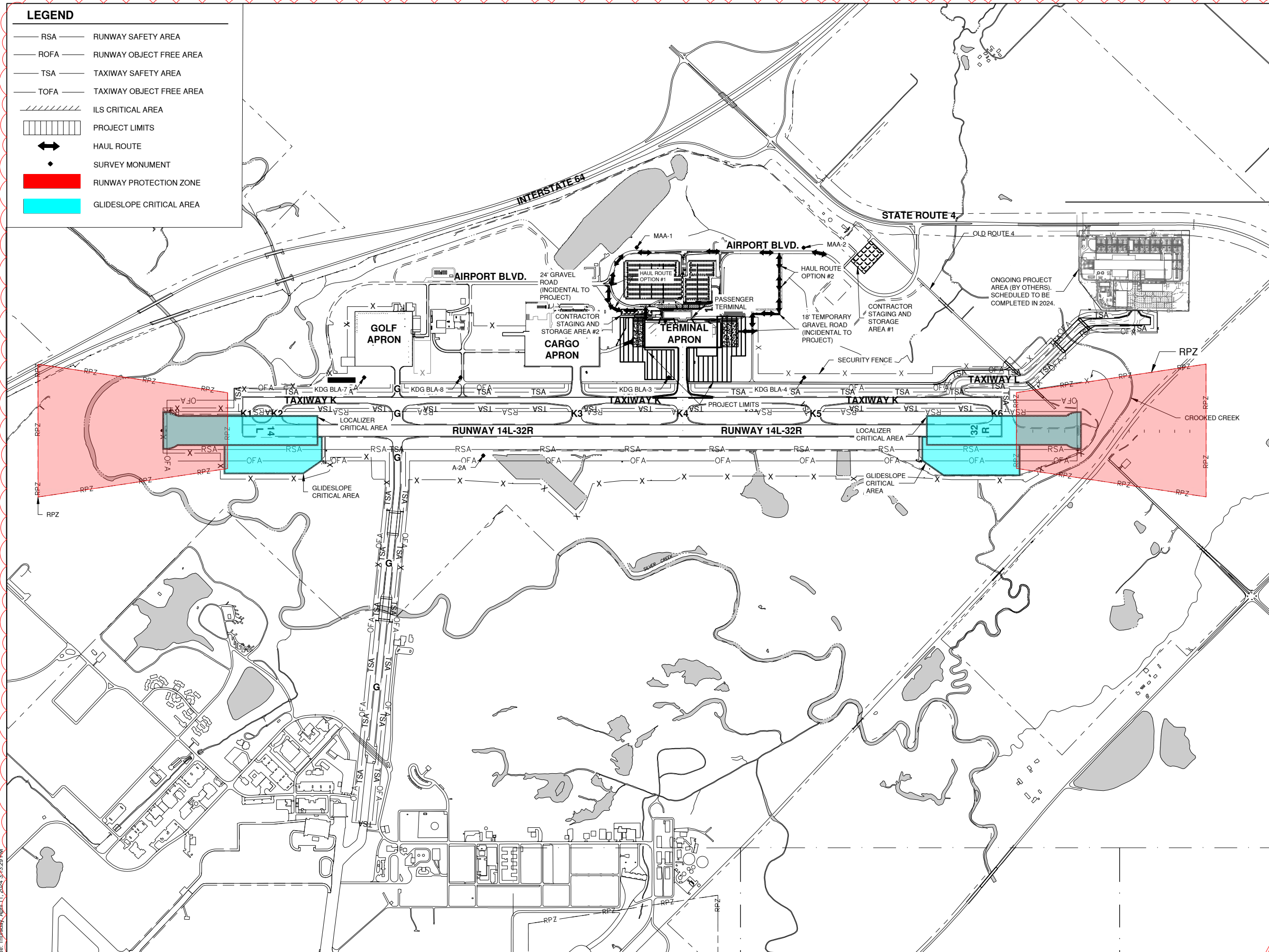

100% SUBMITTAL
MARCH 1, 2024

TERMINAL APRON EXPANSION



MIDAMERICA
ST. LOUIS AIRPORT
ST. CLAIR COUNTY, IL

MARK	DATE	DESCRIPTION
BLV PROJECT NO.	2024-04	
IL PROJECT NO.	BLV-5101	
CMT PROJECT NO.	22001186.00	
CAD DWG FILE:	CRITICAL AREAS.DWG	
DESIGNED BY:	CMT	
DRAWN BY:	CMT	
CHECKED BY:	CMT	
APPROVED BY:	CMT	
COPYRIGHT:	CRAWFORD, MURPHY & TILLY, INC. 2021	

ILS CRITICAL AREAS

Path: K:\MidAmerica\22001186-00_TerminalApron\DrawSheets\CRITICAL AREAS.dwg
Date: Thursday, April 11, 2024 3:43:29 PM

CONSTRUCTION ACTIVITY PLAN GENERAL NOTES:

0. General:

- The CAP Notes sheets are considered part of the CSPP. The full CSPP is located in the appendix of the Project Manual.
- The contractor and all subcontractors shall follow the requirements of the airport's approved Construction Safety and Phasing Plan (CSPP), FAA AC 150/5370-2 (latest version), and all airport safety and security requirements.
- Prior to the start of construction, the contractor shall submit to the airport for approval a Safety Plan Compliance Document (SPCD) in accordance with FAA AC 150/5370-2 (latest version). No construction activity shall begin until the airport has approved the SPCD.
- The CSPP covers operational safety. The contractor shall be responsible for the individual safety of their personnel and meeting OSHA requirements. In addition, the contractor shall provide a company safety plan prior to the pre-bid meeting.
- Prior to the start of construction, the contractor shall sign the SWPPP certification statement.
- All contractor costs associated with the requirements listed on this sheet shall be considered incidental to the contract unless a specific pay item is provided.

1. Coordination:

- Before beginning any construction activity on the airport, the contractor shall become aware of and understand the safety requirements and hazards described in the federal aviation administration advisory circular (AC) 150/5370-2 operational safety on airports during construction (current version). The contractor shall also be responsible to effectively communicate this information to their contract personnel and sub-contractors. A copy of the AC will be provided to the contractor as part of the project documentation and reviewed at a pre-construction meeting prior to start of any work. Reference specification section 40-09. Attendance at the pre-construction meeting is mandatory. The contractor's cost of preparing for and attending this meeting is incidental to the contract.
- Before the pre-construction meeting, the contractor shall supply the airport with a complete work schedule, which will be reviewed at the pre-construction meeting. The schedule shall include a separate line item for each item of work, as well as a start and completion date for each item. The schedule shall be updated on a weekly basis at the mandatory progress/coordination meeting per the project documentation.
- During construction, the contractor shall attend a weekly progress coordination meeting conducted per the project documentation. The owner, engineer and contractor shall at a minimum be in attendance. Operational safety on airports shall be a standing agenda item during the progress/coordination meetings throughout the duration of construction project.
- Scope or schedule changes - the owner and/or engineer will call such coordination conferences as may seem expedient to them for the purpose of assuring coordination of the work covered by this contract and/or scope or schedule changes. The contractor shall attend all such conferences.
- Airport tenant coordination - the owner and/or engineer will coordinate with airport tenants and airlines to notify them of closures and hazards on the airfield due to construction activity.
- FAA ATO coordination - coordination has been taken with the faa technical staff to locate FAA facilities and equipment on the airport. FAA facilities exist within the limits of construction and shall be protected during construction. The ATO contact for this project is Andy Atchley (817) 222-4053.
- Air Traffic Control Tower (ATCT) coordination - the plans have been coordinated with the ATCT. No exceptions taken.
- TSA coordination - the plans have been coordinated with the TSA. No exceptions taken.
- Other projects may be ongoing at the airport during the time of this project. The contractor shall coordinate with other contractors performing work. Any conflicts will be resolved by the airport.
- The contractor shall coordinate, for approval, any proposed changes to the approved project schedule, CAP or CSPP with the airport. This includes any proposed changes to phasing, sequencing, and project delays. Changes that may require further aeronautical review by the FAA, or modification of the approved schedule, CAP or CSPP and/or the critical points shown in the contract documents will require the contractor to submit revisions for approval on FAA Form 7460-1 through the OEAAA system requiring further airspace review and approval from the FAA.

2. Phasing:

- During performance of this project, the airport runways, taxiways, and aircraft parking aprons shall remain in use by aircraft to the maximum extent possible. The project shall be phased to reduce operational impacts at the airport. The overall scope will be bid as one package with two separate work phases .
 - There will be no restrictions on work hours during the project. These restrictions are:
 - Phase 1: There shall be no restrictions on work hours for Phase 1.
 - Phase 1A: There shall be no restrictions on work hours for Phase 1A.
 - Phase 2: There shall be no restrictions on work hours for Phase 2.
- Prior to opening pavements to aircraft, the contractor shall thoroughly sweep and clean the pavements, remove all equipment, and verify that there are no slopes greater than 5% or drop offs greater than 3 inches inside the safety area in accordance with FAA AC 150/5370-2G. Airport operations shall be notified, and the pavement shall be inspected and approved for use. Airport operations must approve the pavement condition and the pavement must be opened to aircraft traffic no later than the planned and agreed-to reopening time. The contractor shall allow sufficient time for airport operations to complete their inspection.
- The phasing has been organized to minimize impact to airport operations.
 - The phasing as noted below reflects the work scheduled during each phase along with requirements placed on the phase. All work shall be completed according to the sequence restrictions placed on each phase reflected below and the construction activity plan sheets.

3. Phase Details:

Phase 1: Shall be completed within the overall construction calendar days (146 consecutive calendar days). All other phases shall occur concurrently with Phase 1. **Any items with lead times greater than the overall calendar days shall be identified after award by the contractor. Calendar days will be able to be suspended at an appropriate time until these items are ready for installation. Additional calendar days may also be awarded to the project for the procurement of these items.**

Phase 1A: Shall be completed within 10 consecutive calendar days, concurrent with Phase 1.

Phase 2: Shall be completed within 14 consecutive calendar days, concurrent with the overall construction calendar days. Phase 2 will include work inside of the Taxiway K4 OFA.

3. Areas and Operations Affected by the Construction Activity:

- Areas of work and staging are shown on the construction activity plan sheets. Aircraft operations shall always have priority over any and all of the contractor's operations.
- All runways and taxiways shall be kept open to aircraft traffic during construction except as noted on the construction activity plan sheets. Airport operations is responsible for the coordination of all movement area and non-movement area closures.
- The contractor, at the direction of the airport, may be required to provide and maintain an emergency response route through the work area for airport emergency vehicles. The emergency response route must be clearly defined, graded to prevent ponding and able to support the frequent use by Airport Rescue and Fire Fighting (ARFF) vehicles. Construction vehicles shall give way to emergency vehicles at all times. Parking or staging of any construction equipment or stockpiling of materials blocking the road or access to the road is prohibited. The plans have been coordinated with the ARFF facility and no exceptions were taken.
- Access to all fire hydrants and stand pipes shall be maintained at all times. Any impact to utilities that would interfere with ARFF operations shall be coordinated and approved by ARFF personnel prior to the execution of such activities.
- Maximum height of contractor's equipment in the work area is restricted to 25-feet above ground elevation unless otherwise noted in the plans. Any equipment over 25-feet necessary to complete the work will require submittal of an FAA Form 7460-1 and requires an airspace review. FAA airspace review will require submittal by the contractor of a separate FAA Form 7460-1 for each piece of equipment that exceeds the maximum height and for each work area as noted in the construction activity plan sheets for the areas the equipment will occupy.**
- Approach and departure surface - construction activities shall not adversely affect the approach and departure surfaces of active runways under the phasing plan. Work areas shall be cleared for a 25' height limit via 7460. The contractor shall ensure that all work or staging areas be cleared of any object that may penetrate the 25' height limit at any times runway 14L-32R is open throughout the project.
- No stockpiling of material will be allowed within any active runway, taxiway, or taxilane object free areas. The contractor shall coordinate and receive approval from airport operations, through the construction management team, before stockpiling any material within the AOA.
- Material stockpiles, if approved, may not obstruct the line-of-sight between the airport ATCT and any active portion of the AOA. Properly stockpiled loose material capable of being displaced must be constrained to prevent its movement as a result of aircraft jet blast or wind conditions.
- Airport operations shall be responsible for notification and issuance of NOTAMs throughout the duration of construction.
- The tables presented below reflect the scheduled work affecting airport runways during each phase and their status for that phase.

Operational Impact Table - 14L-32R

ELEMENT	EXISTING	PHASE 1	PHASE 1A	PHASE 2
Runway 14L-32R				
ADG	V	V	V	V
Width	150	150	150	150
RSA	250*	250*	250*	250*
ROFA	400*	400*	400*	400*

* Measured from runway centerline

Operational Impact Table - Taxiway K

ELEMENT	EXISTING	PHASE 1	PHASE 1A	PHASE 2
Taxiway K				
ADG	V	V	V	V
Width	75	75	75	75
TSA	214*	214*	214*	214*
TOFA	285*	285*	285*	285*

* Measured from taxiway centerline

Operational Impact Table - Taxiway K4

ELEMENT	EXISTING	PHASE 1	PHASE 1A	PHASE 2
Taxiway K4				
ADG	V	V	V	III
Width	100	100	100	100
TSA	107*	107*	107*	59*
TOFA	160*	160*	160*	85.5*

* Measured from taxiway centerline

4. Protection of Navigation Aids (NAVAIDs):

- There are no anticipated impacts to NAVAIDs. See NAVAID Facilities Table below.

NAVAID Facilities Table - Runway 32R

ELEMENT	EXISTING	PHASE 1	PHASE 1A	PHASE 2
Runway 32R	Active	Active	Active	Active
Localizer	Active	Active	Active	Active
Glide Slope	Active	Active	Active	Active
MALSR	Active	Active	Active	Active
PAPI	Active	Active	Active	Active

NAVAID Facilities Table - Runway 14L

ELEMENT	EXISTING	PHASE 1	PHASE 1A	PHASE 2
Runway 14L	Active	Active	Active	Active
Localizer	Active	Active	Active	Active
Glide Slope	Active	Active	Active	Active
MALSR	Active	Active	Active	Active
PAPI	Active	Active	Active	Active

5. Contractor Access:

- The project includes some work areas that are located inside the Aircraft Operations Area (AOA). No personal vehicles of contractor's employees will be allowed inside the secured area of the airport. All material deliveries shall be received in the staging area reserved by the contractor. No delivery trucks will be allowed access to a secured area of the airport beyond this staging area. Stockpiled materials and equipment are not permitted within the active runway safety area and object free zone. The contractor shall receive approval from the engineer and FAA prior to locating stockpiles or equipment within the object free area, safety area, or object free zone. No stockpile within the staging area shall be greater than 25-ft in height. No stockpile within the work zone shall be greater than 15-ft in height.
- When any vehicle, other than one that has prior approval from the airport operator, must travel over any portion of an aircraft movement area, it shall be escorted and properly identified. To operate in those areas during daylight hours, the vehicle must have a flag or beacon attached to it. Any vehicle operating on the movement areas during hours of darkness or reduced visibility must be equipped with a yellow flashing dome-type light in accordance with FAA AC 150/5210-5D.
- All construction vehicles shall be clearly identified for control purposes by prominently displaying the company name on each side of the vehicle on the driver and passenger doors. Vehicles shall also be escorted by a properly marked and equipped vehicle. The identification logos are to be no less than 12"x12", and readable from a distance of 250 feet. They shall be printed or pasted on and must be commercially made. Magnetic signs are also acceptable. In addition, vehicles must display identification media, as specified in the approved security plan.
- All contractor vehicles shall have an operable fire extinguisher located inside the vehicle.
- All vehicle operators having access to the movement area must be familiar with airport procedures for the operation of ground vehicles and the consequences of noncompliance or be escorted by someone who is. As part of the badging process, the contractor shall undergo training for movement within the aircraft movement area. In addition, the contractor shall be briefed on areas they are allowed to move freely and areas where movement is controlled or prohibited.
- Refer to specification SP-9 for badging requirements.
- Vehicle traffic located in or crossing an active movement area must have a working two-way radio in contact with the control tower or be escorted by a person in radio contact with the tower. The driver, through personal observation, shall confirm that no aircraft is approaching the vehicle position. Construction personnel may operate in a movement area without two-way radio communication provided a NOTAM is issued closing the area and the area is properly marked to prevent incursions. Two-way radio communications are required between contractors and the Airport Traffic Control Tower (ATCT) (Scott tower frequency: 128.25 / Scott ground frequency 119.20). Continuous monitoring is required.
- Control of gates - the contractor shall be responsible for maintaining the security of the access gates by keeping the access gate locked or guarded at all times. Should the contractor fail, at any time, to keep the access gate locked or guarded, there shall be a fine of \$500.00 assessed to the contractor plus any fines levied against the airport for the contractor's actions, for each occurrence that the contractor fails to maintain the security of the access gate. All fines assessed to the contractor shall be deducted from any monies due to him/her.
- The contractor shall obtain all necessary permits and temporary easements for the public access road(s) shown on the construction activity plan and shall comply with all requirements, load restrictions and traffic control signage required by the city, county, township and IDOT.
- The contractor shall keep a record of the names of all employees, including subcontractor employees, entering the job site on a daily basis.
- When the contractor is not working, equipment shall be properly stored at the staging area. The contractor may only store equipment and materials at the locations shown on the construction activity plan.
- All pavements, drives or any other areas utilized by the contractor for haul roads or storage areas shall be maintained and repaired to the same condition or better than they were prior to beginning the work. No additional compensation will be made for this work.
- The contractor shall ensure all vehicle and equipment operators utilized on the project are properly trained on the use and operation of the vehicle or equipment.
- The contractor shall notify the Aircraft Rescue and Fire Fighting (ARFF) facility if construction activities will require the blockage of emergency access to the airport.
- The airport reserves the right to restrict access to certain areas of the airport or airfield at time due to operational requirements.

6. Wildlife Management:

- The contractor shall maintain the construction sites, haul routes and storage areas in compliance with industry best management practices to avoid creating wildlife attractants or hazards at the airport.
- The contractor shall be responsible to mitigate any standing water caused by any construction or contractor activities within 24 hours of an event.
- No food or food related debris are to be left or stored within the airport air operations area including any alternative, AOA construction staging. At the contractors staging and storage area outside the AOA, all drums or containers used to hold trash and debris shall be clearly labeled "trash" and be emptied regularly.
- The contractor shall immediately report any damage to gates or fences. access gates shall remain closed when the contractor is not working. The contractor shall be responsible for repairs to any gates or fences caused by negligence of the contractor.
- The contractor shall notify the airport immediately of any wildlife sightings.

7. Foreign Object Debris (FOD) Management & Dust Control:

- The contractor shall become familiar with the requirements of airfield work and Foreign Object and Debris (FOD) Management including dust control. This item shall be specifically addressed in the contractors SPCD as detailed in the project documentation. Reference FAA AC 150/1510-24, Foreign Object Debris (FOD) Management for further instruction.
- The contractor shall not place waste and loose material in active movement areas. Materials tracked on these areas shall immediately be removed.
- Properly stockpiled loose material capable of being displaced must be constrained to prevent its movement as a result of aircraft jet blast or wind conditions.
- The contractor shall ensure all loads are secured and/or covered during transport and be loaded such that no spillage occurs during transit.
- Haul routes, access roads, and any part of active aprons, or taxiways used by construction traffic shall be kept continuously clean at all times. A minimum of one (1) each, mechanical sweeper and vacuum truck shall be kept on site at all times during the life of this contract per the project documentation. The contractor shall also show evidence of availability of replacement equipment meeting the same within two (2) hours of an equipment breakdown or to supplement staged equipment should it be deemed necessary by airport operations for continued contractor operations.
- All sweeper operators shall be trained and badged for unescorted access to the AOA. All personnel who will operate equipment inside the AOA shall receive driver training from airport operations prior to operating on the airfield. Sweeper crews shall monitor all ATCT communications and be attentive of all airport activities and aircraft movements.
- The contractor shall maintain construction areas, including haul roads, staging areas, and adjacent airfield pavements in a clean condition and shall not allow any sizable accumulation of debris in the construction area. In addition to the mechanical sweeper and vacuum, the contractor shall utilize whatever other equipment and means necessary to keep these routes free and clear of dust, debris, mud, etc.
- In such a situation where a significant amount of debris is deposited on active pavements, the contractor shall immediately notify the airport and engineer.
- Airport operations reserves the right to suspend contractor operations when at its discretion the contractor's dust control and FOD management becomes ineffective.
- Hazardous Materials (HAZMAT) Management:**
 - The contractor shall develop a hazardous materials (HAZMAT) management and response plan. Copies of this plan shall be maintained on the jobsite.
 - The contractor shall also develop a HAZMAT communication plan. The plan shall list and include copies of Material Safety Data Sheets (MSDS) for all hazardous materials being handled on the jobsite. Copies of this plan shall be maintained at all staging and storage areas and on the jobsite. Copies of the plan shall also be submitted to airport operations.
 - The contractor shall not refuel equipment within the AOA. The contractor shall maintain on hand a spill response kit to expeditiously contain and clean-up spills resulting from fuel or hydraulic fluid leaks, consistent with their HAZMAT management and response plan.
 - The contractor shall notify the airport operations immediately in the event a release of hazardous material occurs or if signs of potential contamination by hazardous materials are encountered during excavation or other construction activities.

(NOTES CONTINUE ON SHEET GC002)



License No. 184-000613

CONSULTANTS

100% SUBMITTAL
MARCH 1, 2024

TERMINAL APRON EXPANSION



MIDAMERICA
ST. LOUIS AIRPORT
ST. CLAIR COUNTY, IL

11/2/2024 ADDENDUM A

MARK DATE DESCRIPTION

BLV PROJECT NO. 2024-04
IL PROJECT NO. BLV-5101
CMT PROJECT NO: 22001186.00
CAD DWG FILE: 22001186 - GC000.DWG
DESIGNED BY: CMT
DRAWN BY: CMT
CHECKED BY: CMT
APPROVED BY: CMT
COPYRIGHT: CRAWFORD, MURPHY & TILLY, INC. 2021

SHEET TITLE

CONSTRUCTION
ACTIVITY PLAN
NOTES 1

GC001
SHEET 6 OF 68



License No. 184-000613

CONSULTANTS



THIS BAR IS EQUAL TO 2" AT FULL SCALE (22X34)

100% SUBMITTAL
MARCH 1, 2024

TERMINAL APRON EXPANSION



MIDAMERICA
ST. LOUIS AIRPORT
ST. CLAIR COUNTY, IL

4/12/2024 ADDENDUM A

MARK DATE DESCRIPTION

BLV PROJECT NO.	2024-04
IL PROJECT NO.	BLV-5101
CMT PROJECT NO.	22001186.00
CAD DWG FILE:	22001186 - GC100.DWG
DESIGNED BY:	###
DRAWN BY:	CMT
CHECKED BY:	###
APPROVED BY:	###

COPYRIGHT: CRAWFORD, MURPHY & TILLY, INC. 2021

SHEET TITLE

CONSTRUCTION
ACTIVITY PLAN -
PHASE 1

GC102
SHEET 9 OF 68

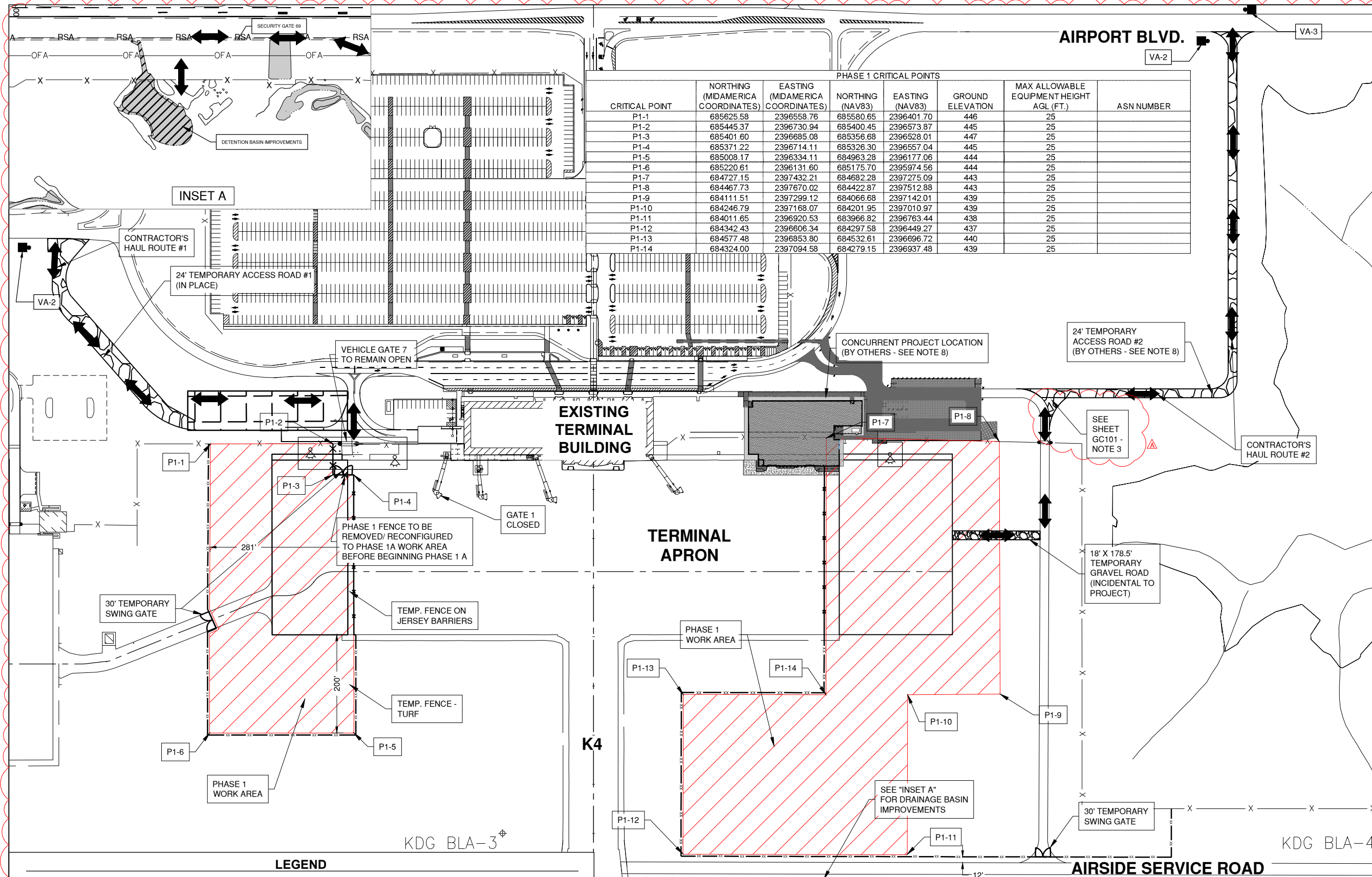

CRITICAL POINT	NORTHING (MIDAMERICA COORDINATES)	EASTING (MIDAMERICA COORDINATES)	NORTHING (NAV83)	EASTING (NAV83)	GROUND ELEVATION	MAX ALLOWABLE EQUIPMENT HEIGHT AGL (FT.)	ASN NUMBER
P1-1	685625.58	2396558.76	685580.65	2396401.70	446	25	
P1-2	685445.37	2396730.94	685400.45	2396573.87	445	25	
P1-3	685401.60	2396685.08	685356.68	2396528.01	447	25	
P1-4	685371.22	2396714.11	685326.30	2396557.04	445	25	
P1-5	685008.17	2396334.11	684963.28	2396177.06	444	25	
P1-6	685220.61	2396131.60	685175.70	2395974.56	444	25	
P1-7	684727.15	2397432.21	684682.28	2397275.09	443	25	
P1-8	684467.73	2397670.02	684422.87	2397512.88	443	25	
P1-9	684111.51	2397299.12	684066.68	2397142.01	439	25	
P1-10	684246.79	2397168.07	684201.95	2397010.97	439	25	
P1-11	684011.65	2396920.53	683966.82	2396763.44	438	25	
P1-12	684342.43	2396606.34	684297.58	2396449.27	437	25	
P1-13	684577.48	2396853.80	684532.61	2396696.72	440	25	
P1-14	684324.00	2397094.58	684279.15	2396937.48	439	25	

- PHASE 1 NOTES:**
- THIS PHASE SHALL CONSIST OF ALL WORK OUTSIDE OF THE TAXIWAY K, K4 AND TERMINAL APRON OFA.
 - PHASE 1 SHALL BE COMPLETED WITHIN THE OVERALL PROJECT CALENDAR DAYS (146 CALENDAR DAYS).
 - ALL PHASES MAY BE CONCURRENT WITH PHASE 1.
 - A TEMPORARY FENCE SHALL BE INSTALLED 142.5 FEET AWAY FROM THE TAXIWAY K4 CENTERLINE AND APRON PARKING CENTERLINE TO THE SOUTH TO ALLOW WORK OUTSIDE OF THE AOA.
 - A TEMPORARY FENCE ON JERSEY BARRIERS SHALL BE INSTALLED 50 FEET AWAY FROM THE EXISTING EDGE OF THE NORTH APRON CONCRETE LIMITS TO ALLOW FOR WORK TO BE PERFORMED OUTSIDE OF THE AOA. GATE 1 WILL BE CLOSED FOR THE DURATION OF THIS PHASE.
 - WORK INSIDE OF THE AOA FOR INSTALLATION OF THE TEMPORARY FENCE AND GRADING OPERATIONS MUST BE DONE IN ACCORDANCE WITH THE AOA REQUIREMENTS.
 - TEMPORARY GATES SHALL BE INSTALLED TO ALLOW ACCESS BETWEEN THE AIRSIDE SERVICE ROAD AND THE EXISTING JPALS ACCESS ROAD.
 - EXISTING ROAD IS IN-PLACE. CONTRACTOR SHALL COORDINATE OPERATIONS WITH ADJACENT ONGOING PROJECTS. CONTRACTOR SHALL REMOVE ROAD AND STAGING AREA AT THE COMPLETION OF THIS PROJECT.

LEGEND

	PHASE 1 WORK AREA		CONTRACTOR HAUL ROUTE
	EXISTING AIRPORT PERIMETER FENCING		PHASING CRITICAL POINT
	PROPOSED TEMPORARY FENCE ON JERSEY BARRIERS		30' TEMPORARY SWING GATE
	PROPOSED TEMPORARY FENCE - TURF		OBJECT FREE AREA
	TAXIWAY SAFETY AREA		
	SIGN VA-X (SEE SHEET GC501 FOR DETAILS)		

Path: K:\MidAmerica\22001186-00_TerminalApron\DrawSheets\22001186 - GC100.dwg
Date: Thursday, April 11, 2024 1:46:00 PM

PHASE 1A CRITICAL POINTS							
CRITICAL POINT	NORTHING (MIDAMERICA COORDINATES)	EASTING (MIDAMERICA COORDINATES)	NORTHING (NAV83)	EASTING (NAV83)	GROUND ELEVATION	MAX ALLOWABLE EQUIPMENT HEIGHT AGL (FT.)	ASN NUMBER
P1A-1	685448.21	2396733.92	685403.29	2396576.85	446	25	
P1A-2	685401.29	2396779.21	685356.37	2396622.13	445	25	
P1A-3	685401.60	2396685.08	685356.68	2396528.01	447	25	
P1A-4	685354.16	2396729.82	685309.24	2396572.75	445	25	

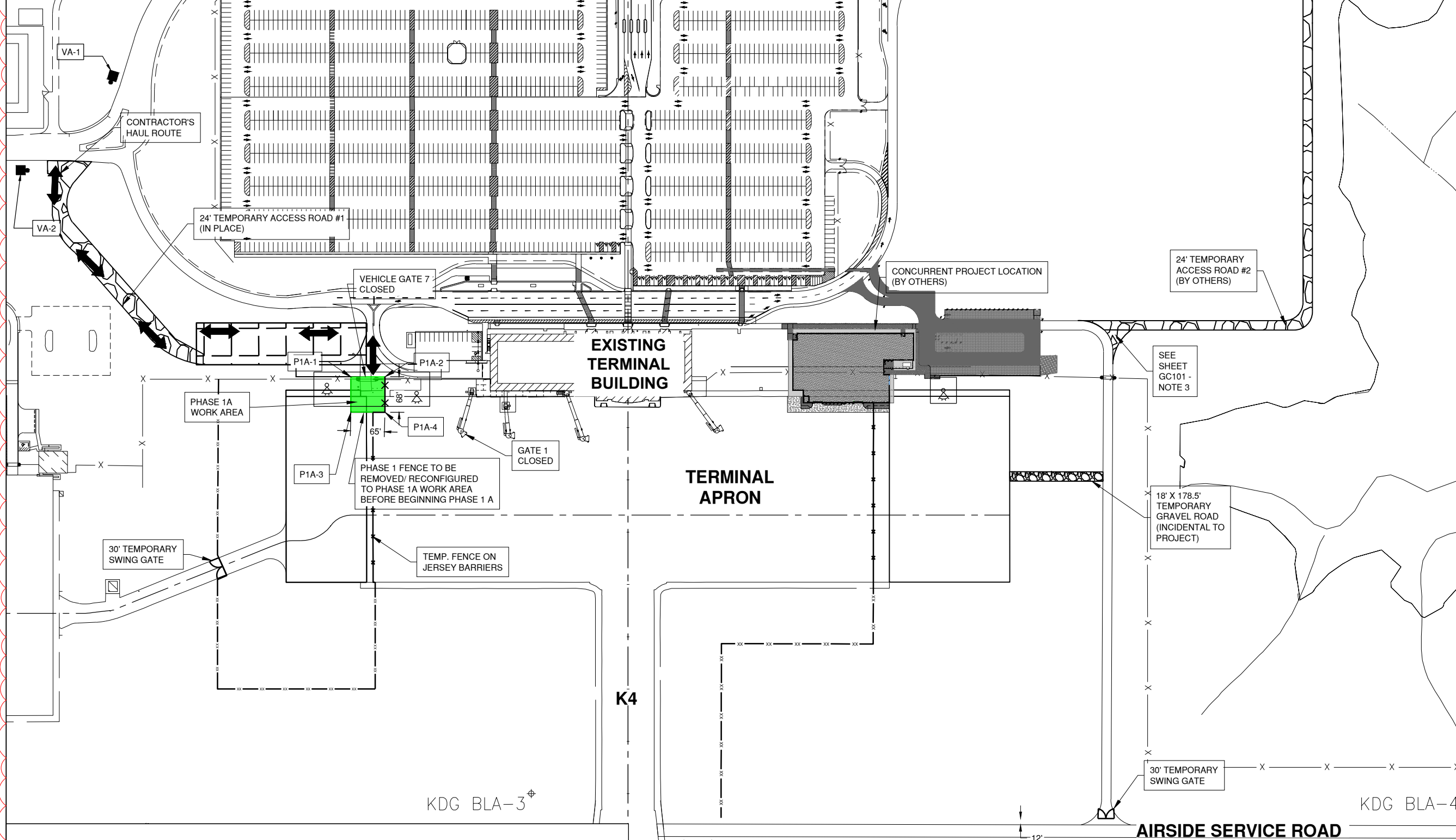

License No. 184-000613
CONSULTANTS

0 60 120 Feet
THIS BAR IS EQUAL TO 2" AT FULL SCALE (22X34)

100% SUBMITTAL
MARCH 1, 2024

TERMINAL APRON EXPANSION

MIDAMERICA
ST. LOUIS AIRPORT
MIDAMERICA
ST. LOUIS AIRPORT
ST. CLAIR COUNTY, IL

MARK	DATE	DESCRIPTION
BLV	PROJECT NO. 2024-04	
IL	PROJECT NO. BLV-5101	
CMT	PROJECT NO. 22001186.00	
CAD	DWG FILE: 22001186 - GC100.DWG	
DESIGNED BY:	###	
DRAWN BY:	CMT	
CHECKED BY:	###	
APPROVED BY:	###	
COPYRIGHT: CRAWFORD, MURPHY & TILLY, INC. 2021		

CONSTRUCTION
ACTIVITY PLAN -
PHASE 1A

LEGEND

- PHASE 1A WORK AREA
- PROPOSED TEMPORARY FENCE ON JERSEY BARRIERS
- TSA TAXIWAY SAFETY AREA
- OFA OBJECT FREE AREA
- SIGN VA-X (SEE SHEET GC501 FOR DETAILS)
- CONTRACTOR HAUL ROUTE
- 4' BARRICADE SPACING FOR CONSTRUCTION PHASE OPERATIONS - RESTRICT VEHICLE MOVEMENTS
- P2-1 PHASING CRITICAL POINT

PHASE 1A NOTES:

1. PHASE 1A SHALL BE CONCURRENT WITH PHASE 1.
2. PHASE 1A SHALL BE COMPLETED WITHIN 10 CALENDAR DAYS.
3. THE CONTRACTOR SHALL GIVE THE AIRPORT A MINIMUM OF 72 HOURS NOTICE BEFORE BEGINNING PHASE 1A.
4. GATE 7 WILL BE CLOSED FOR THE DURATION OF PHASE 1A.

Path: K:\MidAmerica\22001186-00_TerminalApron\DrawSheets\22001186 - GC100.dwg
Date: Thursday, April 11, 2024 2:35:51 PM

PHASE 2 NOTES:

1. THIS PHASE SHALL CONSIST OF DEMOLITION, EARTHWORK AND CONSTRUCTION OF A STORM SEWER PIPE AND INLET IN THE AREA ADJACENT TO TAXIWAY K4 AS SHOWN ON THE CAP. WORK SHALL ALSO INCLUDE EARTHWORK AND CONSTRUCTION OF A PAVED DITCH.
2. ALL WORK IN PHASE 2 SHALL BE COMPLETED CONCURRENTLY WITH PHASE 1.
3. PHASE 2 SHALL BE COMPLETED WITHIN 14 CONSECUTIVE CALENDAR DAYS AND APPROVED BY THE AIRPORT.
4. ALL PERSONNEL MUST BE BADGED OR UNDER ESCORT FOR THE WORK DONE WITHIN PHASE 2 WORK AREAS. WORK INSIDE OF THE AOA MUST BE DONE IN ACCORDANCE WITH THE AOA REQUIREMENTS.
5. THE K4 TAXIWAY TSA AND TOFA WILL BE REDUCED TO ADG III FOR THIS PHASE. THE NEW K4 TSA WILL BE 59' FROM THE K4 CENTERLINE. THE NEW K4 TOFA WILL BE 85.5' FROM THE K4 CENTERLINE. ALL OTHER TAXIWAY AND RUNWAY SAFETY AND OBJECT FREE AREAS WILL REMAIN UNCHANGED.
6. CONTRACTOR SHALL COORDINATE OPERATIONS WITH ADJACENT ONGOING PROJECTS.

PHASE 2 CRITICAL POINTS							
CRITICAL POINT	NORTHING (MIDAMERICA COORDINATES)	EASTING (MIDAMERICA COORDINATES)	NORTHING (NAV83)	EASTING (NAV83)	GROUND ELEVATION	MAX ALLOWABLE EQUIPMENT HEIGHT AGL (FT.)	ASN NUMBER
P2-1	685122.58	2396436.04	685077.68	2396278.98	444	25	
P2-2	684828.68	2396716.48	684783.80	2396559.41	443	25	
P2-3	684543.64	2396415.87	684498.78	2396258.82	441	25	
P2-4	684840.27	2396138.29	684795.39	2395981.25	441	25	
P2-5	684698.90	2396840.35	684654.03	2396683.27	444	25	
P2-6	684628.45	2396807.56	684583.58	2396750.47	444	25	
P2-7	684342.43	2396606.34	684297.58	2396449.27	437	25	
P2-8	684412.29	2396539.98	684367.44	2396382.92	441	25	

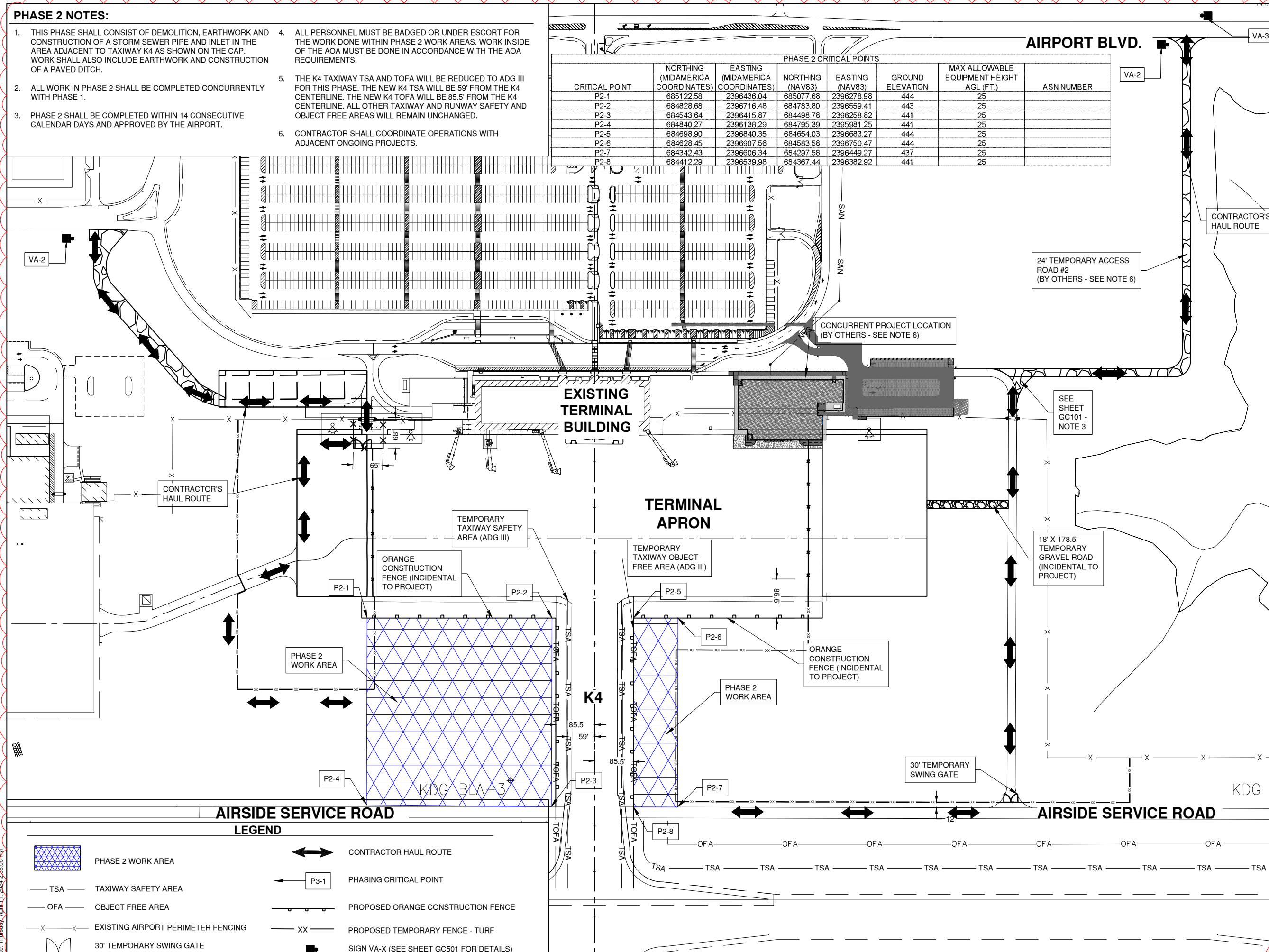

License No. 184-000613
CONSULTANTS

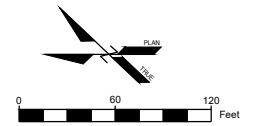

THIS BAR IS EQUAL TO 2" AT FULL SCALE (22X34)

100% SUBMITTAL
MARCH 1, 2024

TERMINAL APRON EXPANSION



MIDAMERICA
ST. LOUIS AIRPORT
ST. CLAIR COUNTY, IL

MARK	DATE	DESCRIPTION
BLV	PROJECT NO. 2024-04	
IL	PROJECT NO. BLV-5101	
CMT	PROJECT NO. 22001186.00	
CAD	DWG FILE: 22001186 - GC100.DWG	
DESIGNED BY:	CMT	
DRAWN BY:	CMT	
CHECKED BY:	CMT	
APPROVED BY:	TWM	
COPYRIGHT: CRAWFORD, MURPHY & TILLY, INC. 2021		

CONSTRUCTION ACTIVITY PLAN - PHASE 2

GC104

Path: K:\MidAmerica\22001186-00_TerminalApron\Draw\Sheets\22001186 - GC100.dwg
 Date: Thursday, April 11, 2024 2:38:05 PM



License No. 184-000613

CONSULTANTS

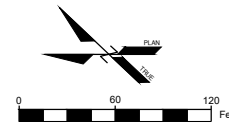

THIS BAR IS EQUAL TO 2" AT FULL SCALE (22X34)

100% SUBMITTAL
MARCH 1, 2024

TERMINAL APRON EXPANSION



MIDAMERICA
ST. LOUIS AIRPORT
ST. CLAIR COUNTY, IL

4/12/2024 ADDENDUM A

MARK	DATE	DESCRIPTION
		BLV PROJECT NO. 2024-04
		IL PROJECT NO. BLV-5101
		CMT PROJECT NO: 22001186.00
		CAD DWG FILE: 22001186 - GC100.DWG
		DESIGNED BY: ###
		DRAWN BY: CMT
		CHECKED BY: ###
		APPROVED BY: ###
		COPYRIGHT: CRAWFORD, MURPHY & TILLY, INC. 2021

TEMPORARY FENCING PLAN

SHEET 12 OF 68

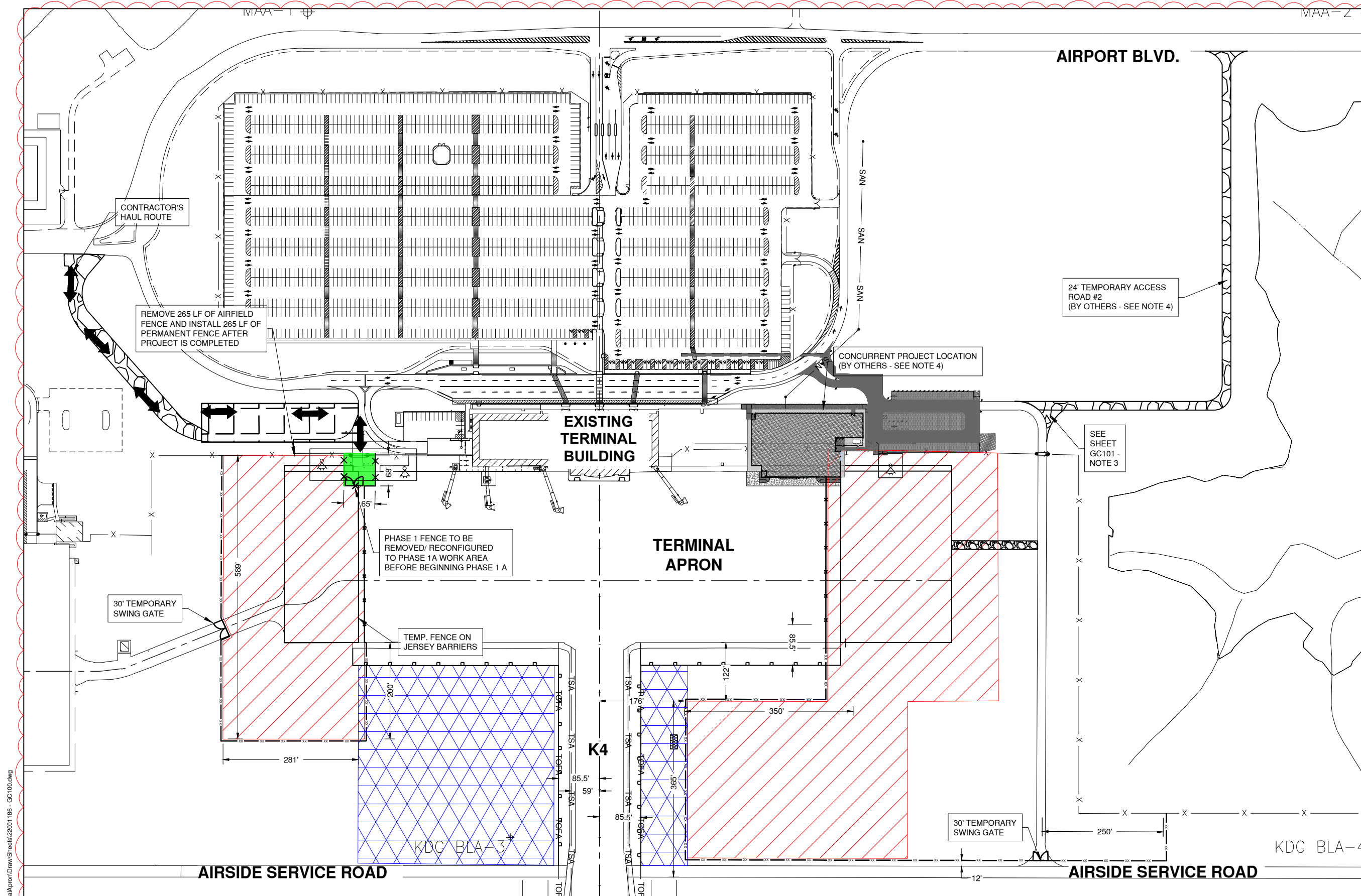

LEGEND

	PHASE 1 WORK AREA		PROPOSED TEMPORARY FENCE ON JERSEY BARRIERS
	PHASE 2 WORK AREA		PROPOSED TEMPORARY FENCE - TURF
	EXISTING AIRPORT PERIMETER FENCING		PROPOSED ORANGE CONSTRUCTION FENCE
	TAXIWAY SAFETY AREA		30' TEMPORARY SWING GATE
	OBJECT FREE AREA		

- TEMPORARY FENCING NOTES:**
1. ALL TEMPORARY FENCE SHALL BE GROUNDED AT 500' INTERVALS. THE COST SHALL BE INCIDENTAL TO THE TEMPORARY FENCE.
 2. EXISTING PERMANENT FENCE SHALL NOT BE REMOVED UNTIL TEMP. FENCE HAS BEEN ACCEPTED BY THE AIRPORT. A SECURE PERIMETER MUST BE KEPT AT ALL TIMES.
 3. FINAL PERMANENT FENCE SHALL BE INSTALLED AND ACCEPTED BY THE AIRPORT BEFORE TEMP. FENCE CAN BE REMOVED.
 4. CONTRACTOR SHALL COORDINATE OPERATIONS WITH ADJACENT ONGOING PROJECTS.
 5. TEMPORARY FENCE PAY ITEM INCLUDES THE INSTALLATION AND REMOVAL OF ALL TEMPORARY FENCE. NO SEPARATE PAYMENT WILL BE MADE FOR TEMPORARY FENCE REMOVALS.

Path: K:\MidAmerica\22001186-00_TerminalApron\Draw\Sheets\22001186 - GC100.dwg
Date: Thursday, April 11, 2024 2:53:56 PM

Path: K:\MidAmerica\22001186-00_TerminalApron\Draw\Sheets\22001186 - LG100.dwg
 Date: Friday, April 12, 2024 9:50:51 PM

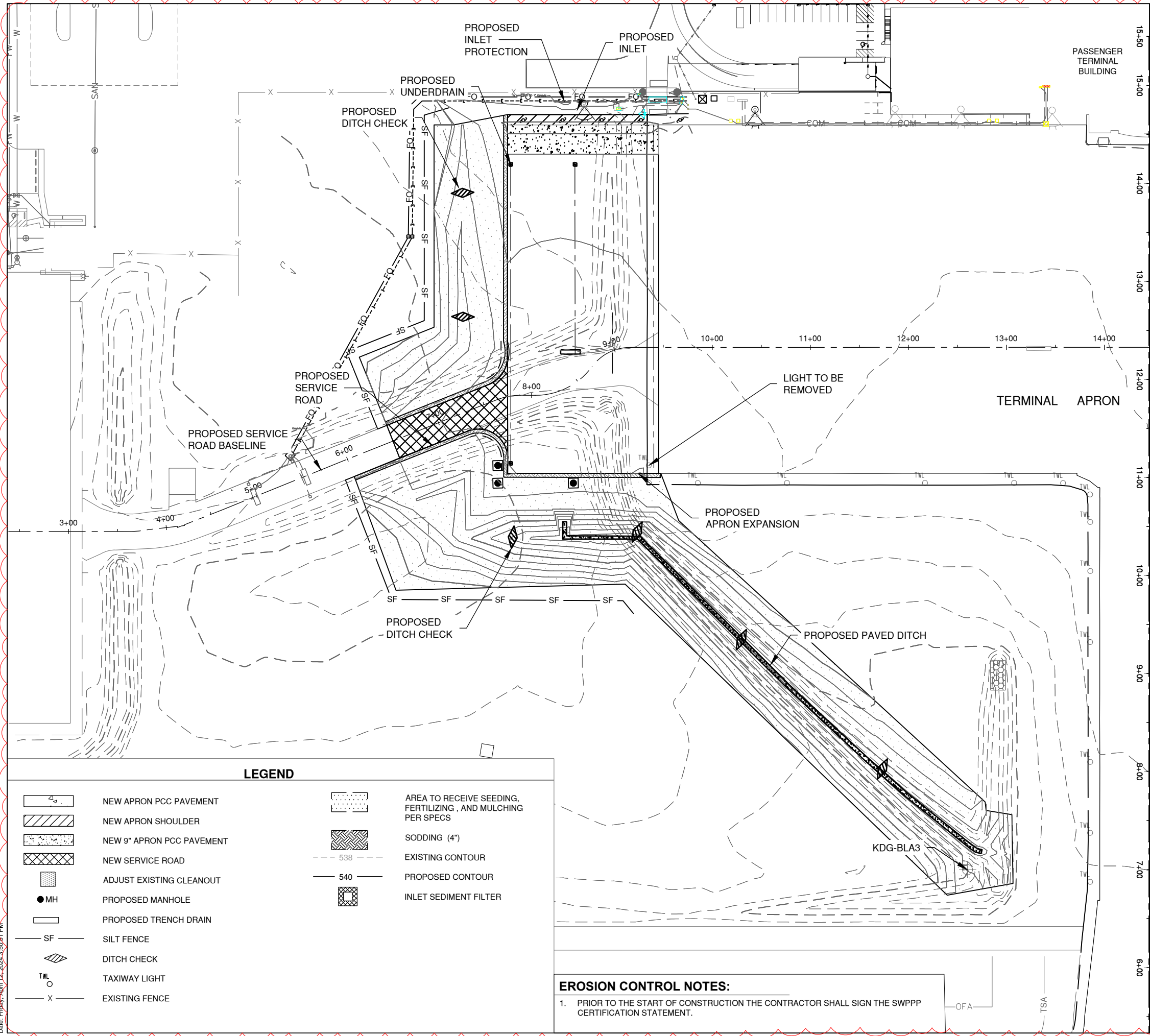

MATCHLINE SEE SHEET LG102 - EROSION CONTROL 2



License No. 184-000613
 CONSULTANTS

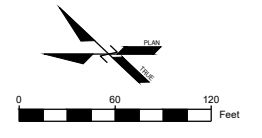

100% SUBMITTAL
 MARCH 1, 2024

TERMINAL APRON EXPANSION



MIDAMERICA
 ST. LOUIS AIRPORT
 ST. CLAIR COUNTY, IL

MARK	DATE	DESCRIPTION
BLV	PROJECT NO. 2024-04	
IL	PROJECT NO. BLV-5101	
CMT	PROJECT NO. 22001186.00	
CAD	DWG FILE: 22001186 - LG100.DWG	
DESIGNED BY:	###	
DRAWN BY:	CMT	
CHECKED BY:	###	
APPROVED BY:	###	
COPYRIGHT: CRAWFORD, MURPHY & TILLY, INC. 2021		

EROSION CONTROL PLAN 1

EROSION CONTROL NOTES:

- PRIOR TO THE START OF CONSTRUCTION THE CONTRACTOR SHALL SIGN THE SWPPP CERTIFICATION STATEMENT.

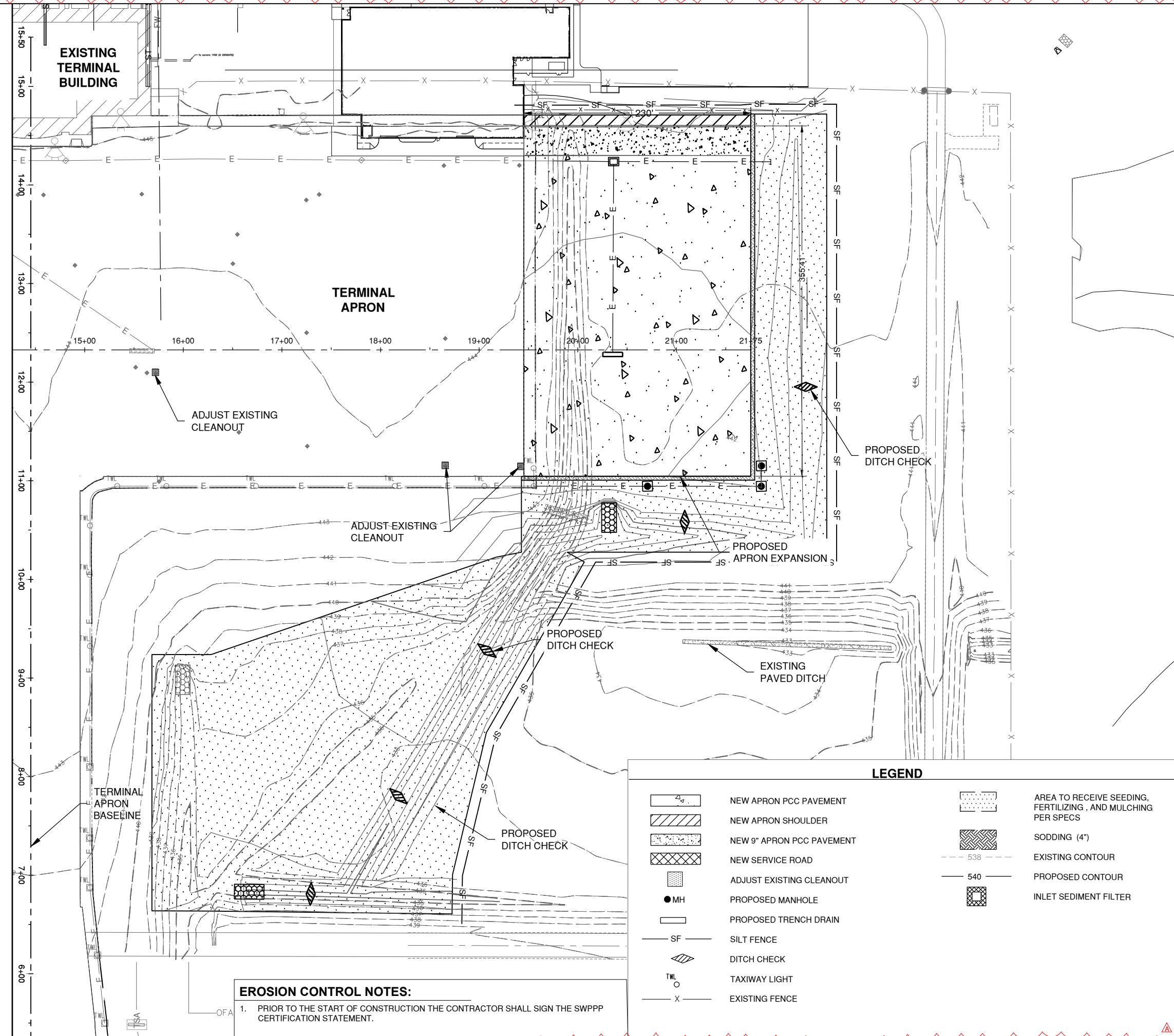
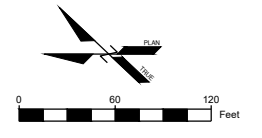

MATCHLINE SHEET LG102 - EROSION CONTROL PLAN 1

100% SUBMITTAL
MARCH 1, 2024

TERMINAL APRON EXPANSION



MIDAMERICA
ST. LOUIS AIRPORT
ST. CLAIR COUNTY, IL

▲ 4/12/2024 ADDENDUM A

MARK	DATE	DESCRIPTION
		BLV PROJECT NO. 2024-04
		IL PROJECT NO. BLV-5101
		CMT PROJECT NO: 22001186.00
		CAD DWG FILE: 22001186 - LG100.DWG
		DESIGNED BY: ###
		DRAWN BY: CMT
		CHECKED BY: ###
		APPROVED BY: ###
		COPYRIGHT: CRAWFORD, MURPHY & TILLY, INC. 2021

LEGEND

	NEW APRON PCC PAVEMENT		AREA TO RECEIVE SEEDING, FERTILIZING, AND MULCHING PER SPECS
	NEW APRON SHOULDER		SODDING (4")
	NEW 9" APRON PCC PAVEMENT		EXISTING CONTOUR
	NEW SERVICE ROAD		PROPOSED CONTOUR
	ADJUST EXISTING CLEANOUT		INLET SEDIMENT FILTER
	PROPOSED MANHOLE		
	PROPOSED TRENCH DRAIN		
	SILT FENCE		
	DITCH CHECK		
	TAXIWAY LIGHT		
	EXISTING FENCE		

EROSION CONTROL NOTES:

1. PRIOR TO THE START OF CONSTRUCTION THE CONTRACTOR SHALL SIGN THE SWPPP CERTIFICATION STATEMENT.

SHEET TITLE
EROSION CONTROL PLAN 2



CONSULTANTS



0 50 100 Feet
THIS BAR IS EQUAL TO 2" AT FULL SCALE (22X34)



GONZALEZ COMPANIES, LLC
525 WEST MAIN STREET
SUITE 125
BELLEVILLE, IL 62220
PHONE: (618) 222-2221
WWW.GONZALEZCOS.COM
ILLINOIS PROFESSIONAL DESIGN FIRM 184.004564

100% DESIGN SUBMITTAL
FEBRUARY 27, 2024

TERMINAL APRON EXPANSION
PROJECT 1

OWNER



MIDAMERICA
ST. LOUIS AIRPORT
ST. CLAIR COUNTY, IL

4/12/2024 ADDENDUM A

MARK DATE DESCRIPTION

BLV PROJECT NO.	2022-14
IL PROJECT NO.	BLV-5087
CMT PROJECT NO.	22001186 GONZALEZ PROJECT NO. 22-1031
CAD DWG FILE:	22001186-CD100.DWG
DESIGNED BY:	FB
DRAWN BY:	FB
CHECKED BY:	JMG
APPROVED BY:	TAS
COPYRIGHT:	CRAWFORD, MURPHY & TILLY, INC. 2021

SHEET TITLE
**EXISTING CONDITIONS
& REMOVAL PLAN**

SHEET 20 OF 62

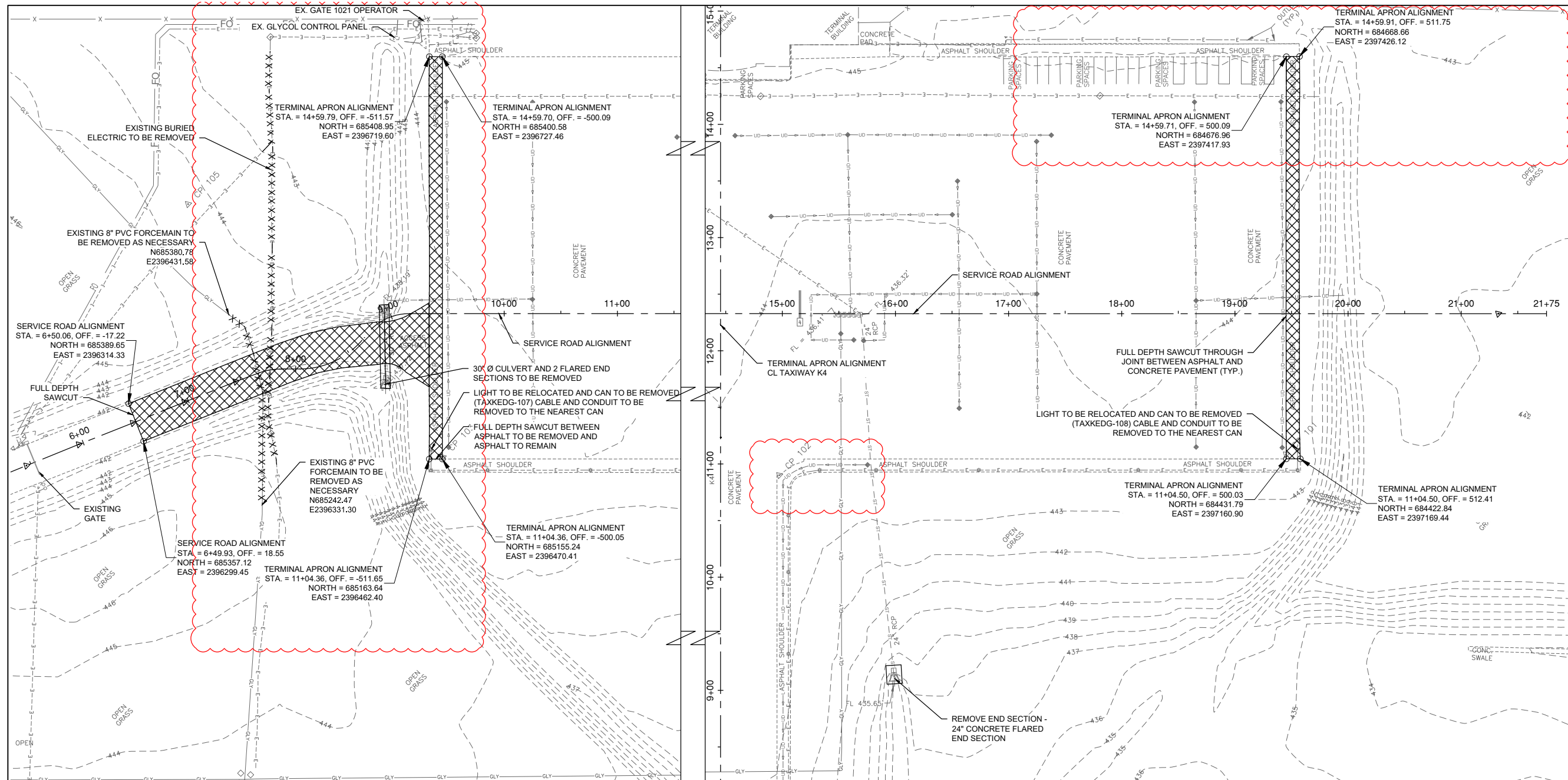

LEGEND

- e - e - e - EXISTING BURIED ELECTRIC
- - - - - EXISTING STORM SEWER
- GLY - - - - EXISTING 8" GLYCOL DISPOSAL PIPE
- - - - - EXISTING UNDERDRAIN
- [Cross-hatched box] REMOVE BITUMINOUS PAVEMENT, 5" THICK
- X X X X X X X - REMOVE BURIED UTILITY (SEE PLAN FOR UTILITY CALLOUT)

NOTES

1. THE LOCATIONS OF ALL EXISTING UTILITIES SHOWN ON THIS PLAN HAVE BEEN DETERMINED FROM THE BEST INFORMATION AVAILABLE AND ARE GIVEN FOR THE CONVENIENCE OF THE CONTRACTOR. THE ENGINEER ASSUMES NO RESPONSIBILITY FOR THEIR ACCURACY.
2. ALL TEMPORARY EROSION CONTROL MEASURES SHALL BE IN PLACE PRIOR TO STARTING ANY REMOVAL WORK. THE CONTRACTOR IS RESPONSIBLE FOR MAINTAINING EROSION CONTROL MEASURES THROUGHOUT THE PROJECT.
3. THE CONTRACTOR SHALL PROTECT THE EXISTING CONCRETE AND ASPHALT PAVEMENT THAT ARE OUTSIDE THE DEMOLITION AREA AND ADJACENT TO THE SPECIFIED PAVEMENT REMOVAL. THE CONTRACTOR SHALL REPAIR ANY DAMAGE TO ADJACENT PAVEMENT AT HIS/HER OWN EXPENSE AS DIRECTED BY THE ENGINEER.
4. SAWCUTTING WILL BE INCLUDED IN THE UNIT COST FOR REMOVE BITUMINOUS PAVEMENT.
5. THE CONTRACTOR IS RESPONSIBLE FOR LOCKOUT/TAGOUT PROCEDURES FOR THE CIRCUITS THAT ARE BEING WORKED ON.
6. THE CONTRACTOR SHALL PROVIDE AND MAINTAIN TEMPORARY JUMPER CONNECTIONS AS NEEDED TO MAINTAIN ALL CIRCUITS THAT ARE TO REMAIN ACTIVE DURING CONSTRUCTION.
7. REMOVED LIGHTS, SIGNS, CABLES, AND OTHER ELECTRICAL COMPONENTS AND MATERIAL SHALL BE PROPERLY DISPOSED OF OFF-SITE UNLESS OTHERWISE DIRECTED BY THE AIRPORT.
8. ACTUAL JUMPER LOCATIONS TO BE DETERMINED BY THE CONTRACTOR PER PHASE AT NO ADDITIONAL COST. JUMPER CIRCUITS ARE TO REMAIN LIVE AT ALL TIMES WITH GALVANIZED STEEL CONDUIT OR PLACED OUTSIDE PROJECT WORK LIMITS WITH APPROVAL OF THE RESIDENT ENGINEER.

Path: I:\Projects\202222-1031 BLV Terminal Apron Expansion\20 Design\CADD\IG Rev Jan 2024\20201186-CD100.dwg
Date: Thursday, April 11, 2024 3:40:21 PM

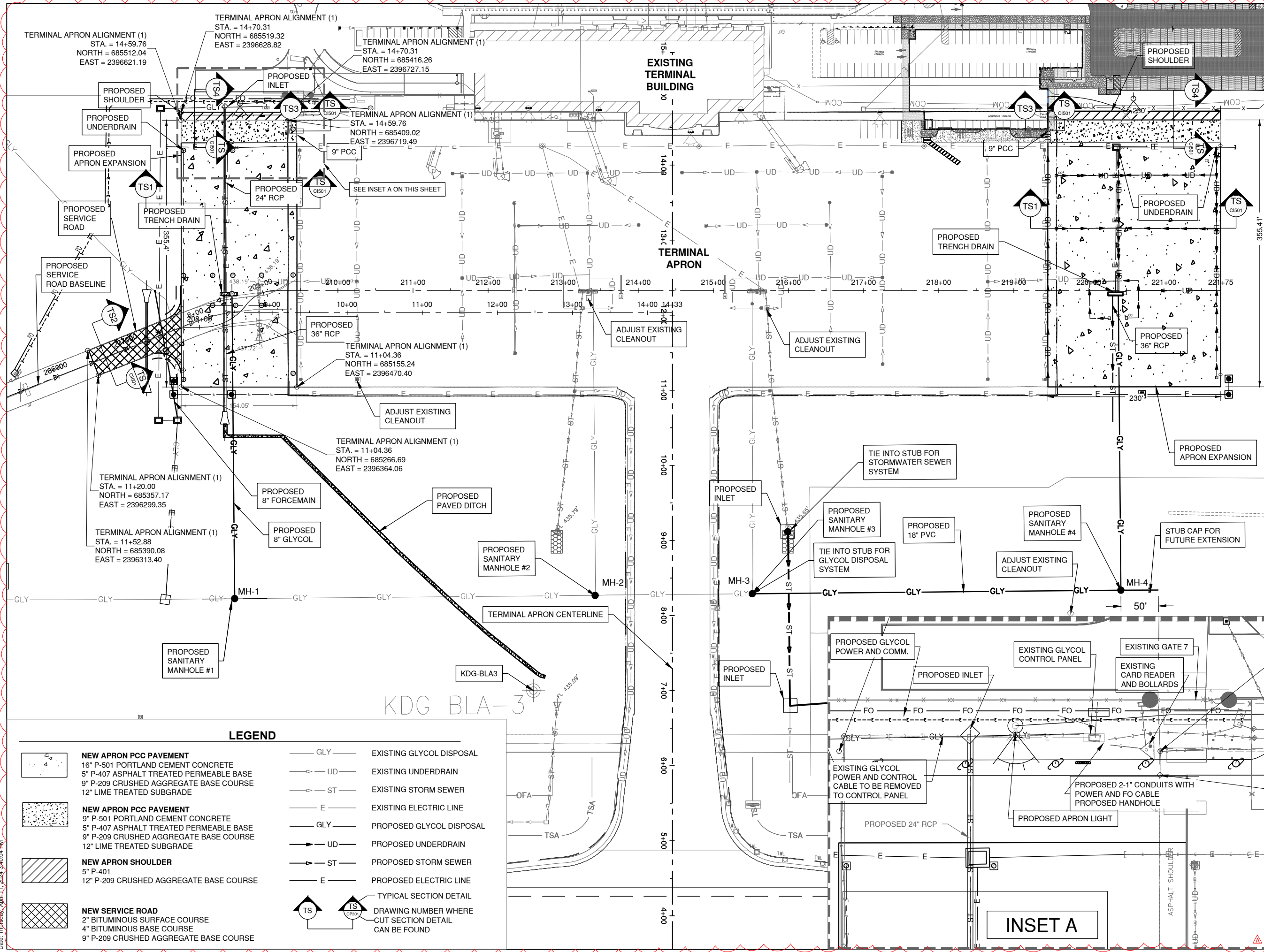
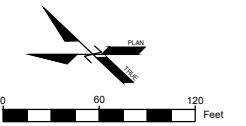

100% SUBMITTAL
MARCH 1, 2024

TERMINAL APRON EXPANSION



MIDAMERICA
ST. LOUIS AIRPORT
ST. CLAIR COUNTY, IL

MARK	DATE	DESCRIPTION
		BLV PROJECT NO. 2024-04
		IL PROJECT NO. BLV-5101
		CMT PROJECT NO. 22001186.00
		CAD DWG FILE: 22001186 - CS100.DWG
		DESIGNED BY: CMT
		DRAWN BY: CMT
		CHECKED BY: CMT
		APPROVED BY: CMT
		COPYRIGHT: CRAWFORD, MURPHY & TILLY, INC. 2021

PROPOSED IMPROVEMENTS

SHEET 21 OF 68

Path: K:\MidAmerica\22001186.00_TerminalApron\DrawSheets\22001186 - CS100.dwg
 Date: Thursday, April 11, 2024 3:40:04 PM

LEGEND

- | | | | |
|--|---|--|---|
| | NEW APRON PCC PAVEMENT
16" P-501 PORTLAND CEMENT CONCRETE
5" P-407 ASPHALT TREATED PERMEABLE BASE
9" P-209 CRUSHED AGGREGATE BASE COURSE
12" LIME TREATED SUBGRADE | | GLY — EXISTING GLYCOL DISPOSAL |
| | NEW APRON PCC PAVEMENT
9" P-501 PORTLAND CEMENT CONCRETE
5" P-407 ASPHALT TREATED PERMEABLE BASE
9" P-209 CRUSHED AGGREGATE BASE COURSE
12" LIME TREATED SUBGRADE | | UD — EXISTING UNDERDRAIN |
| | NEW APRON SHOULDER
5" P-401
12" P-209 CRUSHED AGGREGATE BASE COURSE | | ST — EXISTING STORM SEWER |
| | NEW SERVICE ROAD
2" BITUMINOUS SURFACE COURSE
4" BITUMINOUS BASE COURSE
9" P-209 CRUSHED AGGREGATE BASE COURSE | | E — EXISTING ELECTRIC LINE |
| | | | GLY — PROPOSED GLYCOL DISPOSAL |
| | | | UD — PROPOSED UNDERDRAIN |
| | | | ST — PROPOSED STORM SEWER |
| | | | E — PROPOSED ELECTRIC LINE |
| | | | TS — TYPICAL SECTION DETAIL |
| | | | CP — DRAWING NUMBER WHERE CUT SECTION DETAIL CAN BE FOUND |

INSET A

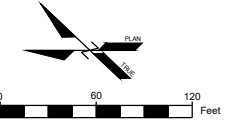

THIS BAR IS EQUAL TO 2" AT FULL SCALE (22X34)

100% SUBMITTAL
MARCH 1, 2024

TERMINAL APRON EXPANSION



MIDAMERICA
ST. LOUIS AIRPORT
ST. CLAIR COUNTY, IL

▲ 4/12/2024 ADDENDUM A

MARK	DATE	DESCRIPTION

BLV PROJECT NO.	2024-04
IL PROJECT NO.	BLV-5101
CMT PROJECT NO.	22001186.00
CAD DWG FILE:	22001186 - CP100.DWG
DESIGNED BY:	CMT
DRAWN BY:	CMT
CHECKED BY:	CMT
APPROVED BY:	CMT
COPYRIGHT:	CRAWFORD, MURPHY & TILLY, INC. 2021

SHEET TITLE

JOINTING PLAN

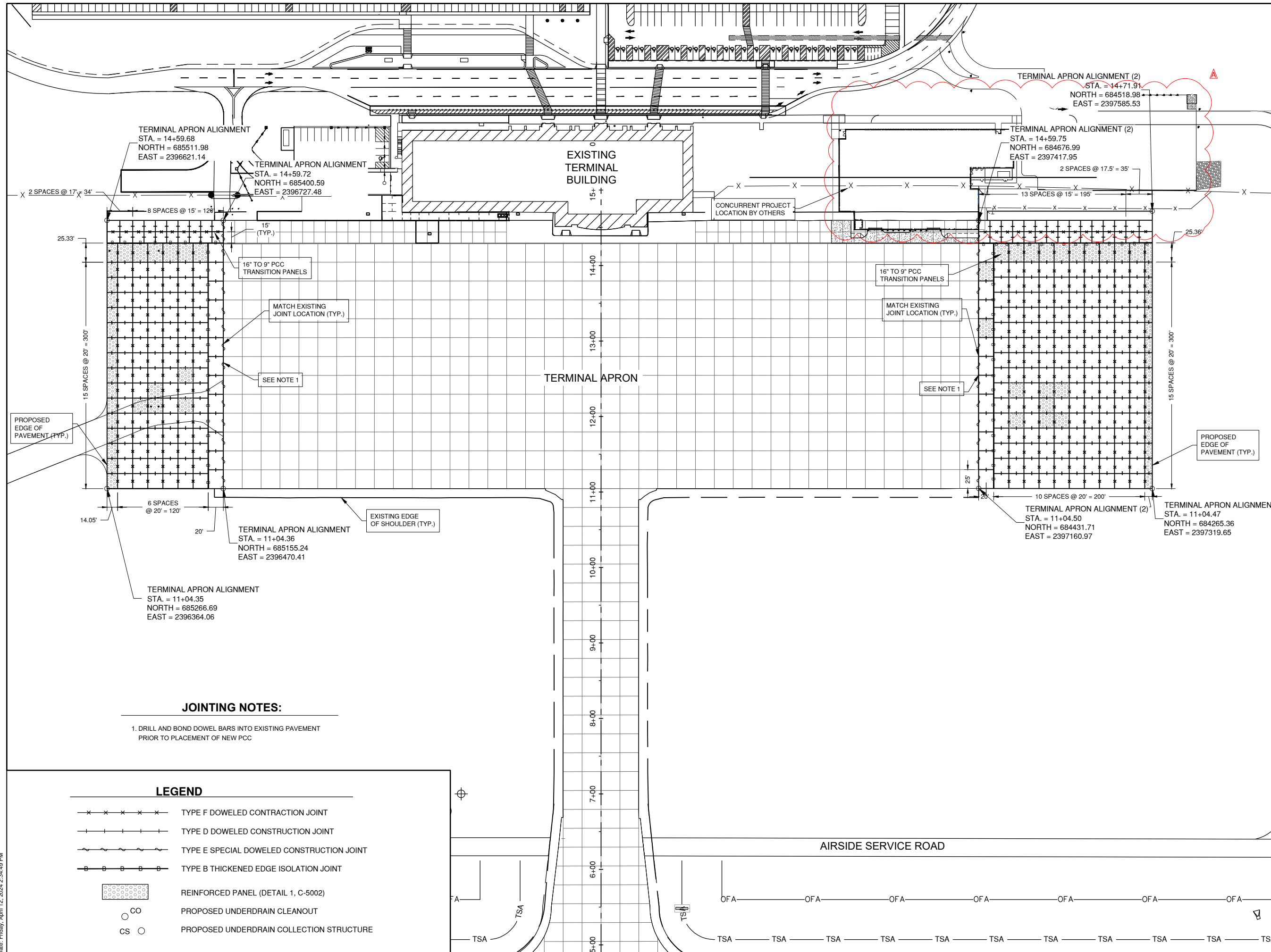

Path: K:\MidAmerica\22001186-00_TerminalApron\Draw\Sheets\22001186 - CP100.dwg
Date: Friday, April 12, 2024 2:34:49 PM

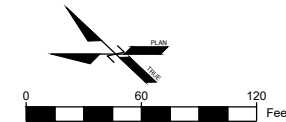

100% SUBMITTAL
MARCH 1, 2024

TERMINAL APRON EXPANSION



MIDAMERICA
ST. LOUIS AIRPORT
ST. CLAIR COUNTY, IL

11/2/2024 ADDENDUM A

MARK	DATE	DESCRIPTION
		BLV PROJECT NO. 2024-04
		IL PROJECT NO. BLV-5101
		CMT PROJECT NO: 22001186.00
		CAD DWG FILE: 22001186 - CG100.DWG
		DESIGNED BY: CMT
		DRAWN BY: CMT
		CHECKED BY: CMT
		APPROVED BY: CMT
		COPYRIGHT: CRAWFORD, MURPHY & TILLY, INC. 2021

**GRADING &
DRAINAGE PLAN 2**

LEGEND

- - - - - EXISTING CONTOURS
- 741.0 — PROPOSED CONTOURS
- ST — EXISTING REINFORCED CONCRETE PIPE
- ST — PROPOSED REINFORCED CONCRETE PIPE
- UD — EXISTING UNDERDRAINS
- UD — PROPOSED UNDERDRAINS
- PROPOSED INLET
- UD-XX PROPOSED UNDERDRAIN RUN NUMBER
- PROP. CLEANOUT/COLLECTION STRUCTURE
- CO-X PROPOSED UNDERDRAIN CLEANOUT CALLOUT
- CS-X PROPOSED UNDERDRAIN COLLECTION STRUCTURE CALLOUT
- △ FLARED END SECTION

NOTE

1. INSTALLATION OF RIP RAP SHALL BE INCIDENTAL TO THE COST OF THE FLARED END SECTION

UNDERDRAIN PIPE SCHEDULE

NAME	PIPE	LENGTH	SLOPE
UD-14	6" PVC	50.59	0.55%
UD-15	6" PVC	70.51	0.55%
UD-16	6" PVC	188.97	0.55%
UD-17	6" PVC	82.89	0.50%
UD-18	6" PVC	32.74	-0.55%
UD-19	6" PVC	130.4	-0.50%
UD-20	6" PVC	33.93	-0.54%
UD-21	6" PVC	72.13	0.54%
UD-22	6" PVC	198.95	-0.50%
UD-23	6" PVC	71.14	-0.55%
UD-24	6" PVC	82.98	-0.50%
UD-25	6" PVC	130.27	-0.50%
UD-26	6" PVC	61.24	-0.59%
UD-27	6" PVC	43.26	0.50%
UD-28	6" PVC	58.84	0.45%
UD-29	6" PVC	22.73	0.50%
UD-30	6" PVC	15.21	-0.82%
UD-31	6" PVC	57.95	0.47%
UD-32	6" PVC	15.68	0.81%
UD-33	6" PVC	26.28	0.47%

STORM STRUCTURE SCHEDULE

STRUCTURE NUMBER	STATION	OFFSET	NORTHING	EASTING	RIM ELEV	SW INVERT
FES 4	10+76.34	586.52	684349.77	2397200.22		437.18
FES 5	6+83.21	206.23	684353.523	2396653.28		434.64
INL-2	6+79.71	156.49	684387.095	2396616.4	438.28	434.50
INL-3	9+11.70	153.48	684549.42	2396782.16	438.5	435.67
TRENCH DRAIN 2	12+28.07	586.27	684454.7	2397309.83	443.15	436.12

STORM PIPE SCHEDULE

REACH	PIPE	LENGTH	SLOPE
SS-4	36" RCP	165.00 LF	0.20%
SS-5	36" RCP	228.00 LF	0.45%
SS-6	24" RCP	50.00 LF	0.30%

MATCHLINE SHEET CS102 - PROPOSED IMPROVEMENTS 2

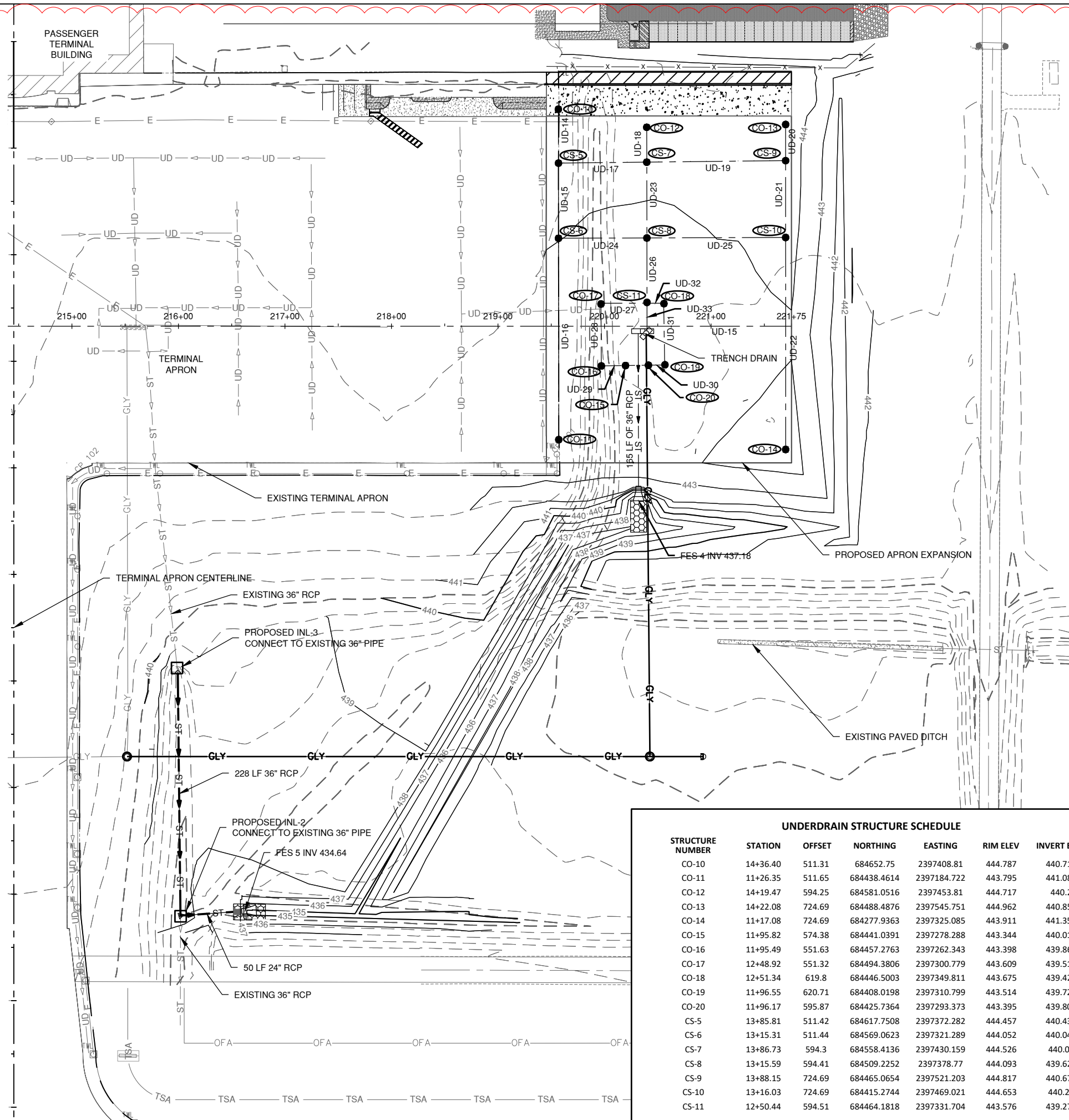

UNDERDRAIN STRUCTURE SCHEDULE

STRUCTURE NUMBER	STATION	OFFSET	NORTHING	EASTING	RIM ELEV	INVERT ELEV
CO-10	14+36.40	511.31	684652.75	2397408.81	444.787	440.712
CO-11	11+26.35	511.65	684438.4614	2397184.722	443.795	441.083
CO-12	14+19.47	594.25	684581.0516	2397453.81	444.717	440.2
CO-13	14+22.08	724.69	684488.4876	2397545.751	444.962	440.855
CO-14	11+17.08	724.69	684277.9363	2397325.085	443.911	441.354
CO-15	11+95.82	574.38	684441.0391	2397278.288	443.344	440.018
CO-16	11+95.49	551.63	684457.2763	2397262.343	443.398	439.867
CO-17	12+48.92	551.32	684494.3806	2397300.779	443.609	439.516
CO-18	12+51.34	619.8	684446.5003	2397349.811	443.675	439.427
CO-19	11+96.55	620.71	684408.0198	2397310.799	443.514	439.724
CO-20	11+96.17	595.87	684425.7364	2397293.373	443.395	439.804
CS-5	13+85.81	511.42	684617.7508	2397372.282	444.457	440.434
CS-6	13+15.31	511.44	684569.0623	2397321.289	444.052	440.044
CS-7	13+86.73	594.3	684558.4136	2397430.159	444.526	440.02
CS-8	13+15.59	594.41	684509.2252	2397378.77	444.093	439.629
CS-9	13+88.15	724.69	684465.0654	2397521.203	444.817	440.672
CS-10	13+16.03	724.69	684415.2744	2397469.021	444.653	440.28
CS-11	12+50.44	594.51	684464.1818	2397331.704	443.576	439.271

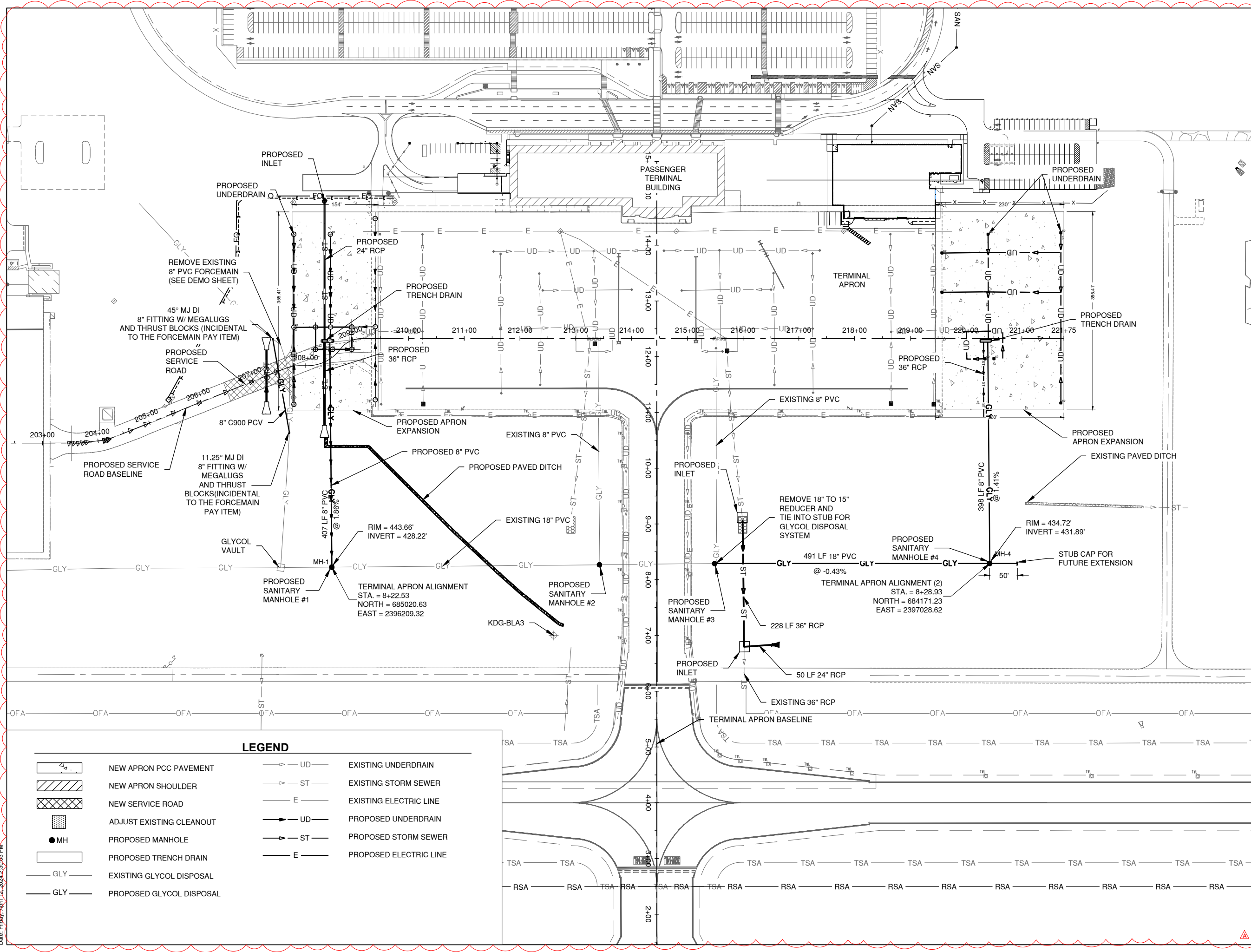
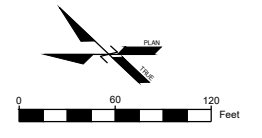

100% SUBMITTAL
MARCH 1, 2024

TERMINAL APRON EXPANSION



MIDAMERICA
ST. LOUIS AIRPORT
ST. CLAIR COUNTY, IL

11/2/2024 ADDENDUM A

MARK	DATE	DESCRIPTION
		BLV PROJECT NO. 2024-04
		IL PROJECT NO. BLV-5101
		CMT PROJECT NO: 22001186.00
		CAD DWG FILE: <UNSAVED DRAWING>
		DESIGNED BY: CMT
		DRAWN BY: CMT
		CHECKED BY: CMT
		APPROVED BY: CMT
		COPYRIGHT: CRAWFORD, MURPHY & TILLY, INC. 2021

SHEET TITLE
GLYCOL IMPROVEMENTS

Path: C:\Users\cdm\OneDrive\local\temp\B\6A25-1\Unsaved Drawings- Date: Friday, April 12, 2024 2:30:58 PM

LEGEND

- | | | | |
|--|--------------------------|--|------------------------|
| | NEW APRON PCC PAVEMENT | | EXISTING UNDERDRAIN |
| | NEW APRON SHOULDER | | EXISTING STORM SEWER |
| | NEW SERVICE ROAD | | EXISTING ELECTRIC LINE |
| | ADJUST EXISTING CLEANOUT | | PROPOSED UNDERDRAIN |
| | PROPOSED MANHOLE | | PROPOSED STORM SEWER |
| | PROPOSED TRENCH DRAIN | | PROPOSED ELECTRIC LINE |
| | EXISTING GLYCOL DISPOSAL | | |
| | PROPOSED GLYCOL DISPOSAL | | |

CONSULTANTS



0 40 80 Feet
THIS BAR IS EQUAL TO 2" AT FULL SCALE (22X34)



GONZALEZ COMPANIES, LLC
525 WEST MAIN STREET
SUITE 125
BELLEVILLE, IL 62220
PHONE: (618) 222-2221
WWW.GONZALEZCOS.COM
ILLINOIS PROFESSIONAL DESIGN FIRM 184.004564

100% DESIGN SUBMITTAL
FEBRUARY 27, 2024

TERMINAL APRON EXPANSION
PROJECT 1

OWNER



MIDAMERICA
ST. LOUIS AIRPORT
ST. CLAIR COUNTY, IL

4/12/2024 ADDENDUM A

MARK	DATE	DESCRIPTION

BLV PROJECT NO. 2022-14

IL PROJECT NO. BLV-5087

CMT PROJECT NO: 22001186 GONZALEZ PROJECT NO: 22-1031

CAD DWG FILE: 22001186-CM100.DWG

DESIGNED BY: FB

DRAWN BY: FB

CHECKED BY: JMG

APPROVED BY: TAS

COPYRIGHT: CRAWFORD, MURPHY & TILLY, INC. 2021

SHEET TITLE

APRON MARKING PLAN

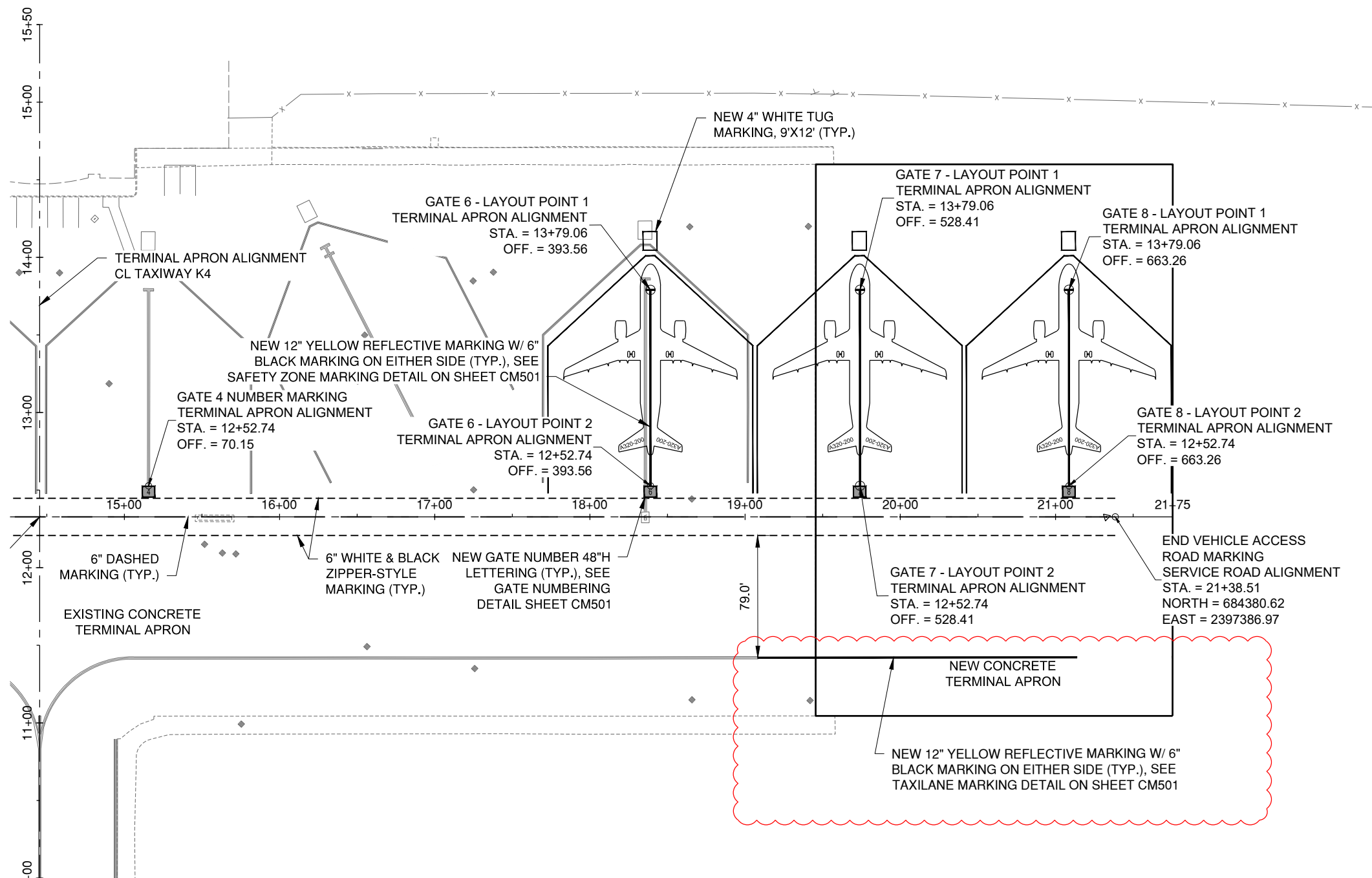

MARKING PLAN

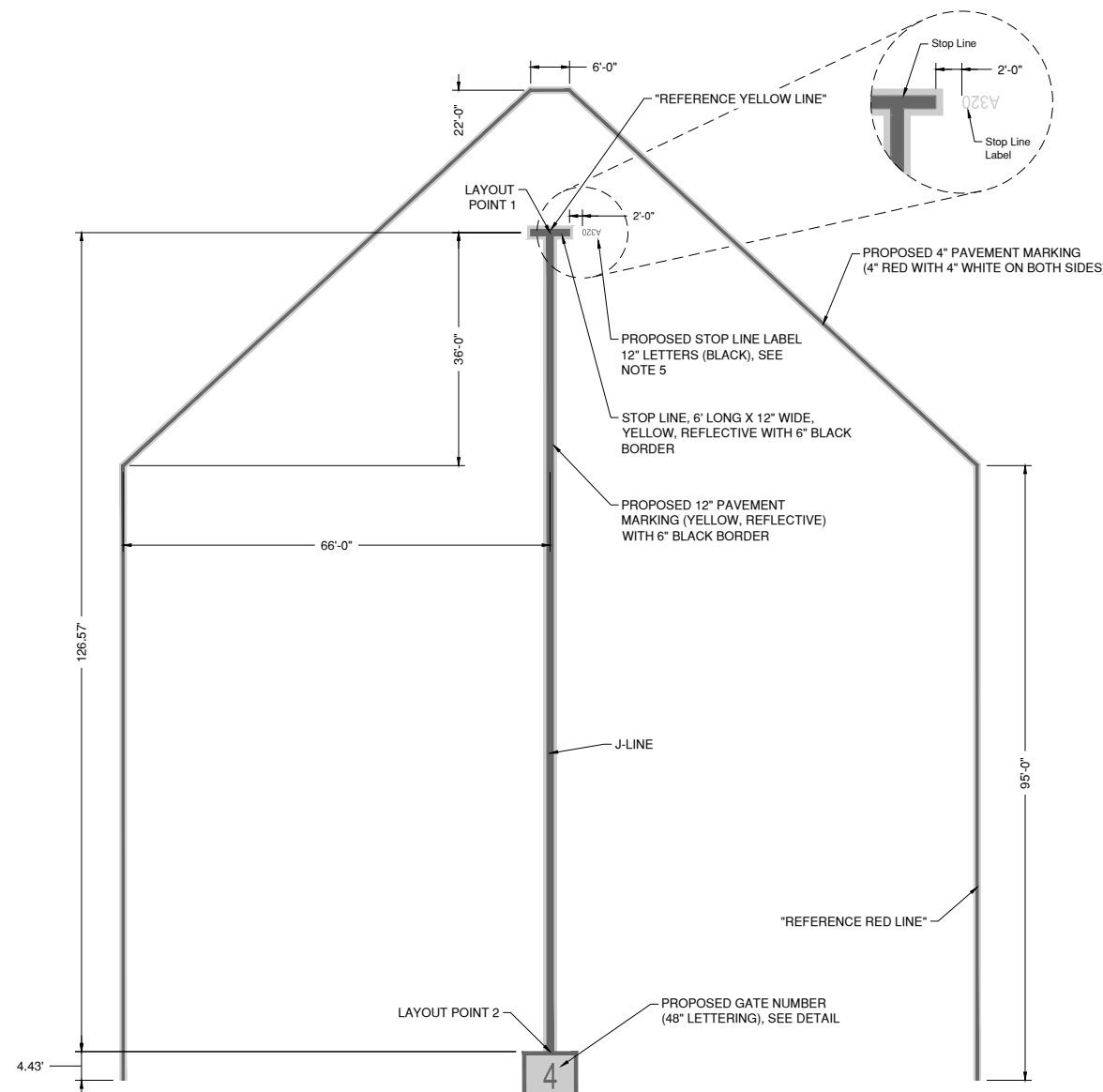
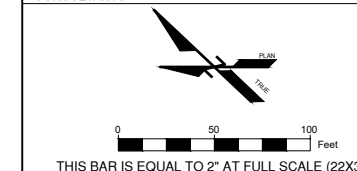

GATE PARKING AND SAFETY ZONE MARKING DETAIL
 NOT TO SCALE

- DETERMINE LOCATION NOSE WHEEL STOP LINE (REFERENCE YELLOW LINE).
- MEASURE AND MARK A POINT FROM FIRST NOSE WHEEL STOP LINE TO TOP OF SAFETY ZONE (22' FROM END OF LINE).
 - FROM THIS POINT, MEASURE AND MARK TWO POINTS PERPENDICULAR TO THE J-LINE (3')
- MEASURE AND NOTE THE POSITION FROM NOSE WHEEL STOP LINE BACK TOWARDS THE MAIN LANDING GEAR POSITION (36' FROM BEGINNING OF J-LINE).
 - FROM THIS NOTED POSITION, MEASURE AND MARK TWO POINTS, PERPENDICULAR TO THE J-LINE AT 66'.
 - FROM THESE TWO POINTS, MEASURE AND MARK TWO POINTS, PARALLEL TO THE J-LINE AT 95'.
- CONNECT POINTS (REFERENCE RED LINE).
- STOP LINE LABELS SHALL BE BLACK WITH 12" HIGH INSCRIPTION IN CONFORMANCE WITH THE DETAILS PROVIDED IN FAA ADVISORY CIRCULAR 150/5340-1M, APPENDIX A (OR LATEST REVISION). LOCATE THE NEAREST CHARACTER 24-INCHES FROM THE END OF THE STOP LINE AS SHOWN. PAY QUANTITY FOR EACH STOP LINE LABEL WILL BE 2 SQ FT.

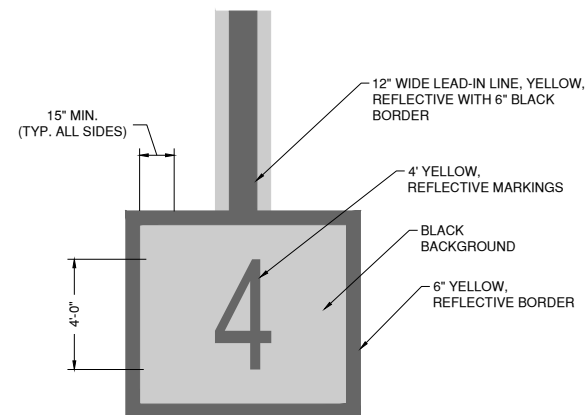

GATE NUMBERING DETAIL
 NOT TO SCALE

- ALL MARKINGS 4" YELLOW AND REFLECTIVE ON BLACK BACKGROUND WITH 15" OFFSET FROM NUMERALS TO BORDER. BORDER IS 6" YELLOW AND REFLECTIVE.
- MARKINGS BASED ON VARIOUS GUIDANCE. ACRP REPORT RECOMMENDED YELLOW ON BLACK AND 2" LETTER HEIGHT. 4" LETTER HEIGHT BASED ON OTHER AIRPORT'S MARKINGS.

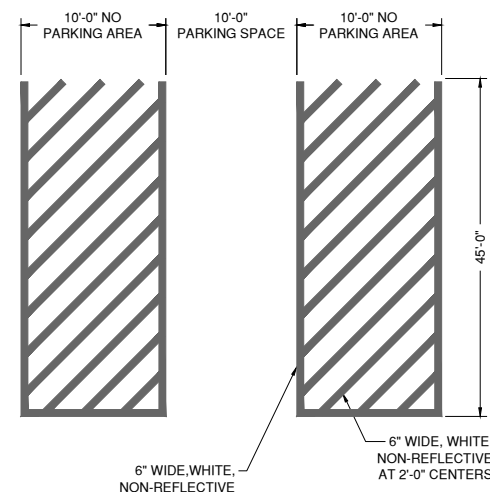

FUEL TRUCK PARKING SPACE MARKING
 NOT TO SCALE

- ALL MARKINGS WHITE AND NON-REFLECTIVE.
- NUMBER OF PARKING SPACES SHALL BE AS NOTED ON PLANS OR AS DIRECTED BY THE ENGINEER OR OWNER.
- SPACE NUMBERS SHALL BE DETERMINED IN THE FIELD BY OWNER.
- SPACE NUMBER SHALL BE 6" STENCILED LABELS AND SHALL BE PLACED AT THE DIRECTION OF THE AIRPORT.
- SPACE NUMBERS MARKING SHALL BE INCIDENTAL TO THE PROJECT.

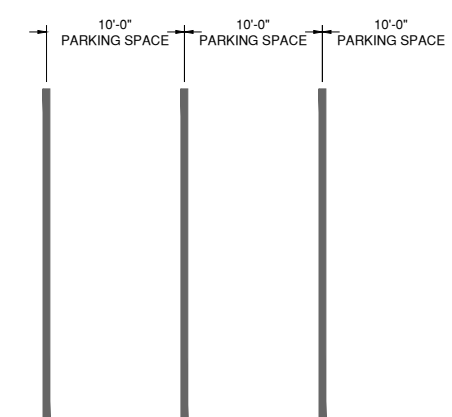

GSE PARKING SPACE MARKING
 NOT TO SCALE

- ALL MARKINGS WHITE AND NON-REFLECTIVE.
- NUMBER OF PARKING SPACES SHALL BE AS NOTED ON PLANS OR AS DIRECTED BY THE ENGINEER OR OWNER.
- SPACE NUMBERS SHALL BE DETERMINED IN THE FIELD BY OWNER.
- SPACE NUMBER SHALL BE 6" STENCILED LABELS AND SHALL BE PLACED AT THE DIRECTION OF THE AIRPORT.
- SPACE NUMBERS MARKING SHALL BE INCIDENTAL TO THE PROJECT.

CONSULTANTS



0 50 100 Feet
THIS BAR IS EQUAL TO 2" AT FULL SCALE (22X34)



GONZALEZ COMPANIES, LLC
525 WEST MAIN STREET
SUITE 125
BELLEVILLE, IL 62220
PHONE: (618) 222-2221
WWW.GONZALEZCOS.COM
ILLINOIS PROFESSIONAL DESIGN FIRM 184.004564

100% DESIGN SUBMITTAL
FEBRUARY 27, 2024

TERMINAL APRON EXPANSION
PROJECT 1

OWNER



MIDAMERICA
ST. LOUIS AIRPORT
ST. CLAIR COUNTY, IL

4/12/2024 ADDENDUM A

MARK	DATE	DESCRIPTION

BLV PROJECT NO. 2022-14

IL PROJECT NO. BLV-5087

CMT PROJECT NO: 22001186 GONZALEZ PROJECT NO: 22-1031

CAD DWG FILE: 22001186-CM500.DWG

DESIGNED BY: FB

DRAWN BY: FB

CHECKED BY: JMG

APPROVED BY: TAS

COPYRIGHT: CRAWFORD, MURPHY & TILLY, INC. 2021

SHEET TITLE

MARKING AND
SIGNAGE DETAILS

SHEET 51 OF CM502 62

GENERAL NOTES

ALL BOLTS 3/8" (M10) HEXHEAD ZINC OR CADMIUM PLATED.
ALL DIMENSIONS ARE IN INCHES (MILLIMETERS) UNLESS OTHERWISE SHOWN

(A)	2 x 2 x var. (51 x 51 var.)
(B)	1 1/4 x 1 1/4 x 12 (44 x 44 x 300)
(C)	2 1/4 x 2 1/4 x 60 (57 x 57 x 1500)
(D)	2 1/2 x 2 1/2 x 18 (64 x 64 x 450)
(E)	2 1/4 x 2 1/4 x 36 (57 x 57 x 900)

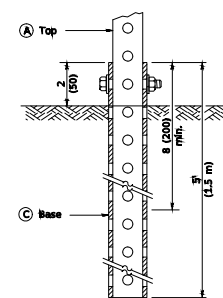

GROUND MOUNT DETAIL

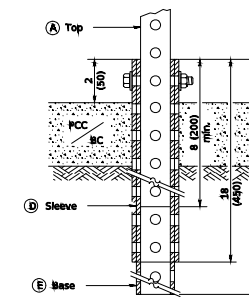

PAVEMENT MOUNT DETAIL

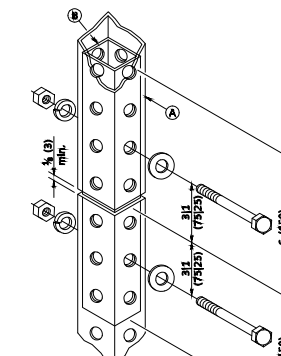

SPLICE DETAIL

TELESCOPING STEEL SIGN SUPPORT DETAIL

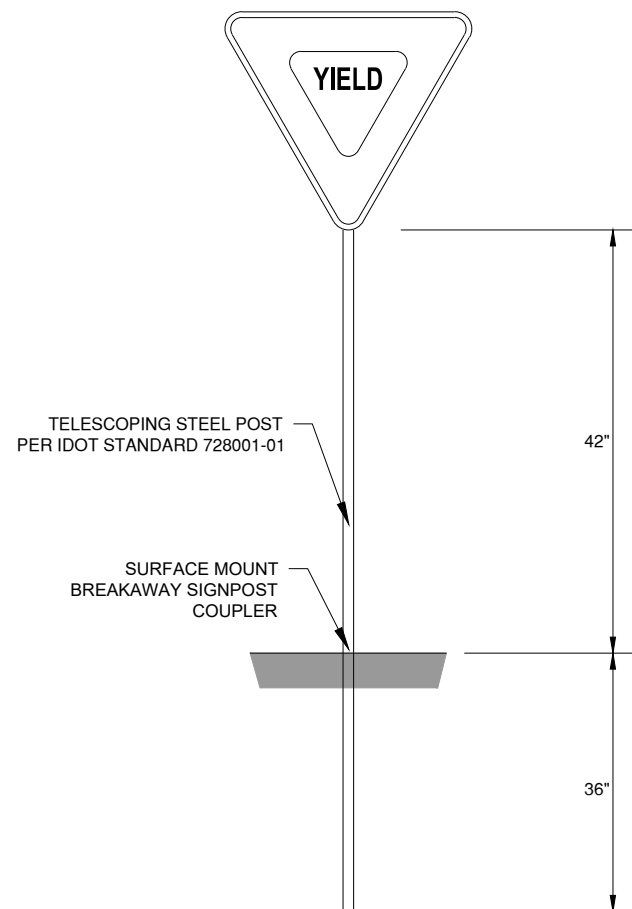

SERVICE ROAD YIELD SIGN DETAIL
N.T.S.

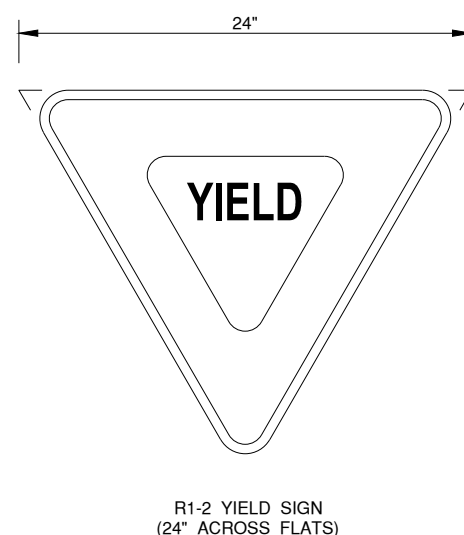

R1-2 YIELD SIGN
(24" ACROSS FLATS)
COLORS:
LEGEND - RED (RETROREFLECTIVE)
BACKGROUND - WHITE (RETROREFLECTIVE)

REF: MANUAL ON UNIFORM TRAFFIC CONTROL DEVICES (MUTCD)
STANDARD HIGHWAY SIGNS 2009 (ENGLISH) EDITION

YIELD SIGN DETAIL
N.T.S.

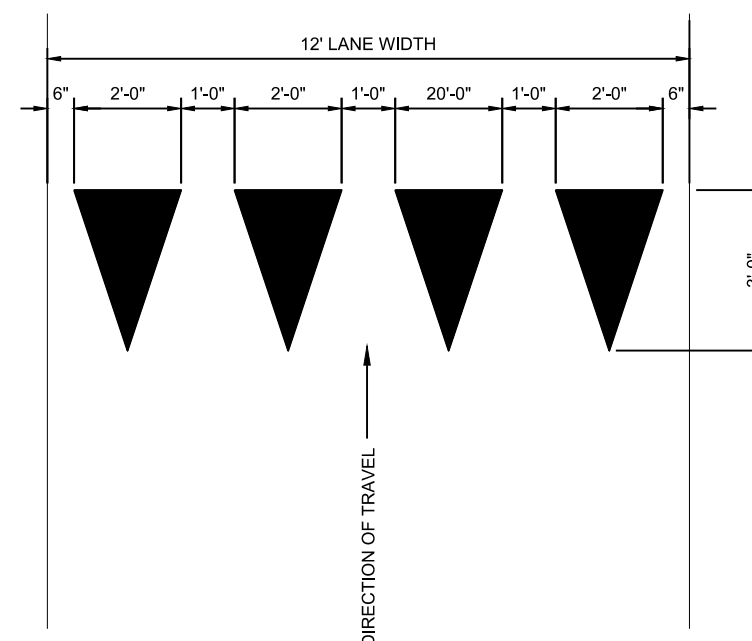

YIELD LINE DETAIL
N.T.S.

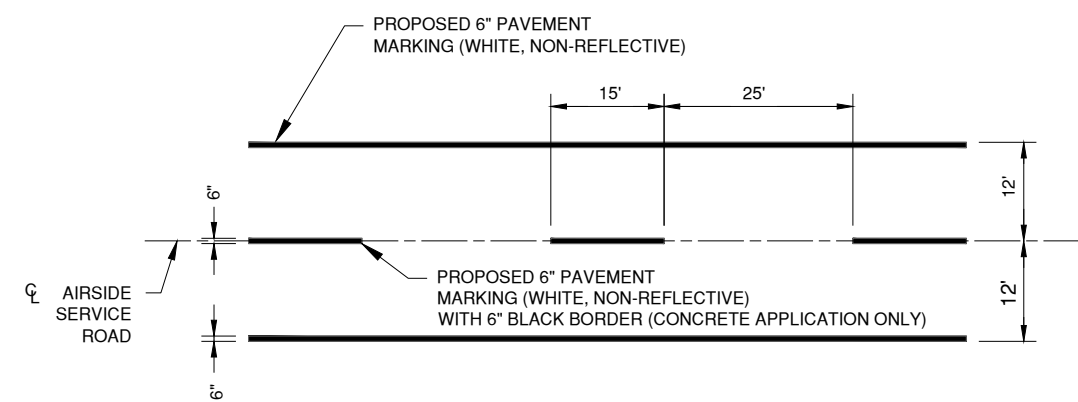

VEHICULAR ROADWAY MARKING
N.T.S.

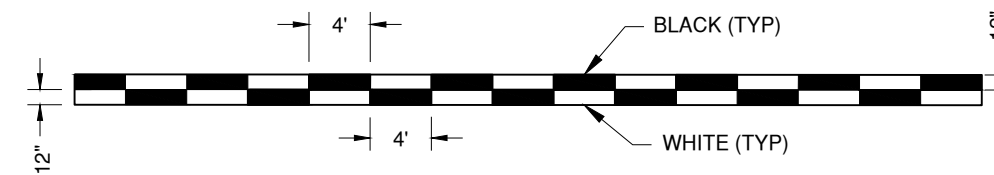

ROADWAY EDGE STRIPES, WHITE, ZIPPER STYLE
N.T.S.

USE ZIPPER STRIPES TO DELINEATE SERVICE ROAD EDGES ON NEW AND EXISTING CONCRETE APRON.

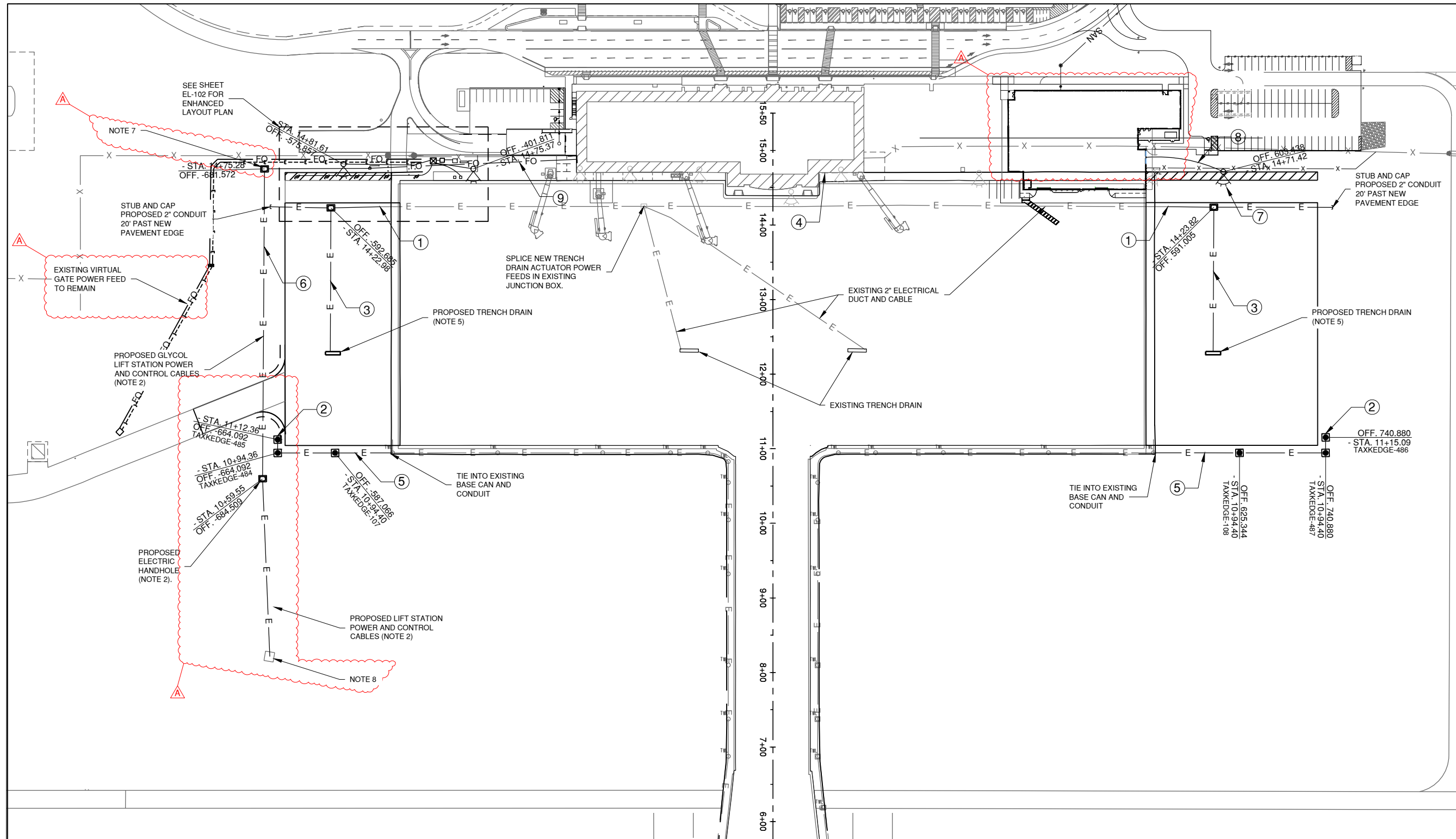
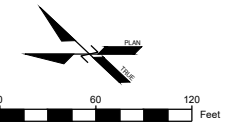

100% SUBMITTAL
MARCH 1, 2024

TERMINAL APRON EXPANSION



MIDAMERICA
ST. LOUIS AIRPORT
ST. CLAIR COUNTY, IL

MARK	DATE	DESCRIPTION

- ### KEYNOTES
- ① TIE INTO EXISTING 2" CONDUIT STUB. EXTEND DUCT BANK TO CONNECT TO PROPOSED TRENCH DRAIN FOR NEW GLYCOL VALVE ACTUATORS.
 - ② TERMINATE COUNTERPOISE WIRE WITH 3/4" X 10' COPPER CLAD GROUND ROD. GROUND ROD SHALL BE INCIDENTAL TO COUNTERPOISE WIRE.
 - ③ 1-WAY 2" ELECTRICAL DUCT (C.E.) WITH XLP-USE POWER CABLE (4 X #10, 1 X #10 GROUND) AND CONTROL CABLE (7 X #14). GLYCOL VALVE ACTUATOR POWER CIRCUITS SHALL BE 208V, 3-PHASE. CONTROL CABLES SHALL TERMINATE AT GLYCOL CONTROLLER.
 - ④ EXISTING GLYCOL VALVE CONTROLLER ON TERMINAL BUILDING WALL TO BE MODIFIED. SEE ELECTRICAL DETAILS 2.
 - ⑤ 2 X 1/C #8 5KV L-824 CABLE IN 2" CONDUIT FOR NEW BASE-MOUNTED TAXIWAY EDGE LIGHTS. SPLICE NEW CABLE ONTO EXISTING CIRCUIT AT EXISTING BASE CAN. CENTER COUNTERPOISE OVER NEW DUCT AS SHOWN IN DETAILS.
 - ⑥ NEW GLYCOL POWER AND CONTROL CABLES FROM EXISTING LIFT STATION CONTROL PANEL SHALL BE:
 - * 6 X #6, 2 X #10 GND (PUMP POWER) AND 8 X #14 (PUMP PROTECTION) IN NEW 2" PVC CONDUIT
 - * 8 X #12, #12 GND (FLOAT SWITCH CONTROL)
 - * MANUFACTURER'S 4-20mA CABLE (LEVEL TRANSDUCER) IN NEW 1" PVC CONDUIT.
 - ⑦ NEW FLOODLIGHT LUMINAIRE MOUNTED ON 60' POLE. FIXTURE SHALL BE CAROLINA HIGH MAST MODEL USR2-600-G-40-80-N4-1-GC-R-TV-F2 OR EQUIVALENT. NEW APRON LIGHTS SHALL BE CONTROLLED VIA THE EXISTING LIGHTING CONTROLLER LOCATED IN CUSTOMS AND BORDER PROTECTION BUILDING (CBP) ELECTRICAL ROOM 132 (ADD. ALT 1).
 - ⑧ 2 X #8 XLP-USE, 1 X #10 XLP-USE GND. IN 2" CONDUIT (480V FLOODLIGHTS) AND 2 X #10, #10 GND. IN 1" CONDUIT (120V RECEPTACLE). 480V APRON LIGHTING CIRCUIT SHALL BE ENERGIZED FROM EXISTING PANEL "L1." PROVIDE 20A, 2-POLE CIRCUIT BREAKER IN PANEL. 120V CIRCUIT SHALL BE ENERGIZED FROM EXISTING PANEL "P1." PROVIDE 20A, 1-POLE CIRCUIT BREAKER IN PANEL. BOTH PANELS ARE LOCATED IN CBP ELECTRICAL ROOM 132. SEE DETAIL SHEET EL501, (ADD. ALT-1).
 - ⑨ PROPOSED 6-STRAND MULTI-MODE FIBER OPTIC CABLE IN EXISTING CONDUIT TO BMS INSIDE TERMINAL BUILDING. COORDINATE WITH AIRPORT IT FOR TERMINATION AND LOCATION OF PATCH PANEL.

- ### NOTES
1. ALL ELECTRICAL INSTALLATIONS WITHIN GLYCOL TRENCH DRAINS SHALL CONFORM WITH MINIMUM NEC STANDARDS FOR A CLASS 1, DIVISION 2 AREA. GLYCOL LIFT STATION WET WELL ELECTRICAL INSTALLATIONS SHALL CONFORM WITH NEC STANDARDS FOR A CLASS 1, DIVISION 1 AREA.
 2. CONTRACTOR SHALL INSTALL NEW GLYCOL POWER AND CONTROL CONDUCTORS BETWEEN NEW LIFT STATION CONTROLLER AND EXISTING LIFT STATION WET WELL.
 3. ALL WORK PERTAINING TO PROPOSED APRON FLOODLIGHTS AND LIGHTING CONTROLS SHALL BE CONTINGENT ON THE AWARD OF ADDITIVE ALTERNATE 1.
 4. CONTRACTOR SHALL COORDINATE WORK IN CUSTOMS AND PATROL BUILDING WITH AIRPORT MAINTENANCE STAFF.
 5. VALVE ACTUATOR INSTALLATION MUST BE SUITABLE FOR A SUBMERSIBLE ENVIRONMENT. CONTRACTOR SHALL PROVIDE ALL CONDUITS, CABLE GLANDS, POTTING, AND OTHER MATERIALS REQUIRED TO ENSURE A WATERTIGHT ACTUATOR INSTALLATION.
 6. CONTRACTOR SHALL FIELD LOCATE EXISTING UTILITIES PRIOR TO CONSTRUCTION. CONTRACTOR SHALL BE RESPONSIBLE FOR DAMAGE TO UTILITIES CAUSED DURING CONSTRUCTION.
 7. REMOVE EXISTING DUPLEX CONTROLLER. INSTALL NEW DUPLEX CONTROLLER ON UNITSTRUT RACK AND FOUNDATION. CONNECT EXISTING 480V, 3-PHASE SERVICE
 8. INSTALL NEW FLOATS AND LEVEL TRANSDUCER IN EXISTING WET WELL. REFER TO DETAILS ON SHEET 59B.

- ### LEGEND
- EXISTING BASE-MOUNTED TAXIWAY EDGE LIGHT
 - PROPOSED BASE-MOUNTED TAXIWAY EDGE LIGHT
 - EXISTING ELECTRICAL CIRCUIT
 - PROPOSED ELECTRICAL CIRCUIT
 - PROPOSED ELECTRIC HANDHOLE
 - EXISTING APRON FLOODLIGHT
 - PROPOSED APRON LIGHT POLE, 60' MOUNTING HEIGHT WITH 6 LUMINAIRES (ADD. ALT 1)
 - PROPOSED OUTLET POST

BLV PROJECT NO. 2024-04
IL PROJECT NO. BLV-5101
CMT PROJECT NO: 22001186.00
CAD DWG FILE: 22001186 - EL100.DWG
DESIGNED BY: ###
DRAWN BY: CMT
CHECKED BY: ###
APPROVED BY: ###
COPYRIGHT: CRAWFORD, MURPHY & TILLY, INC. 2021

SHEET TITLE
PROPOSED ELECTRICAL LAYOUT & LIGHTING PLAN
SHEET 52 OF 68

Path: K:\MidAmerica\22001186-00_TerminalApronDraw\Sheets\22001186 - EL100.dwg
Date: Thursday, April 18, 2024 11:43:31 AM

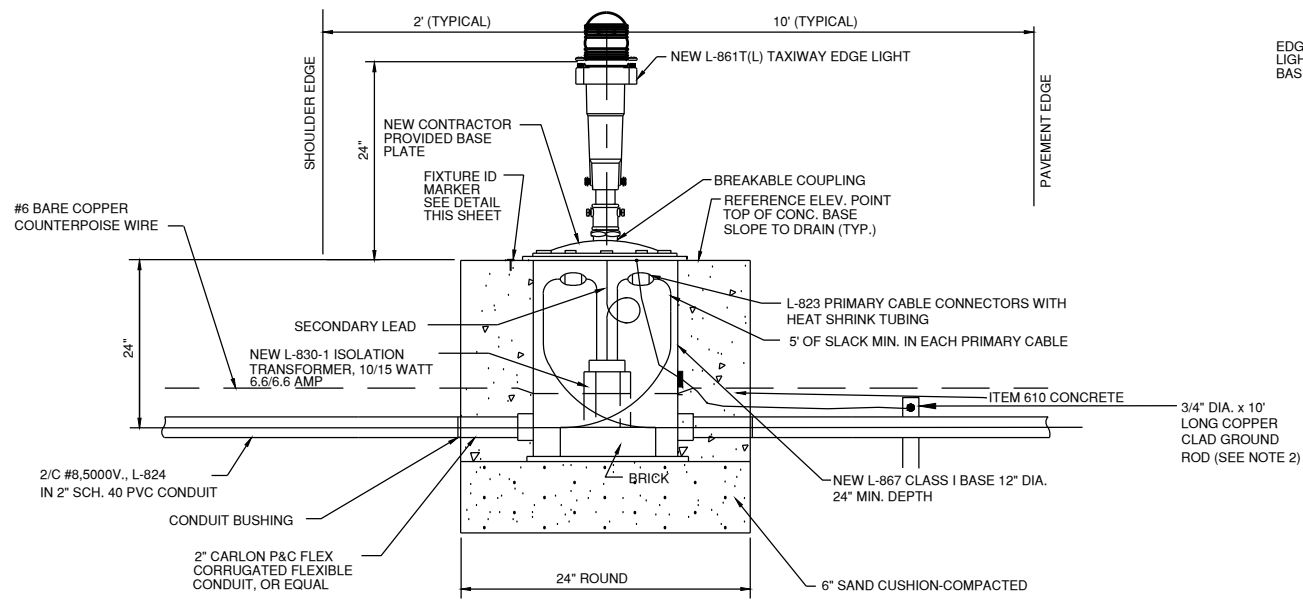

BASE MOUNTED MEDIUM INTENSITY LED TAXIWAY LIGHTS
N.T.S.

1. INSTALL 2" FLEXIBLE CONDUIT BETWEEN CAN AND PVC CONDUIT UNDER PAVED SHOULDER.
2. INSTALL 1/C #6 AWG BARE COPPER GROUND JUMPER CONNECTED TO GROUND LUG OUTSIDE BASE CAN AND EXOTHERMICALLY WELD TO GROUND ROD.
3. COPPER CLAD GROUND ROD SHALL BE LOCATED OPPOSITE COUNTERPOISE WIRE WITH RESPECT TO CAN AND THE TWO SEPARATED BY MIN. OF 12". COUNTERPOISE WIRE SHALL NOT BE BONDED TO CAN.
4. CONTRACTOR MAY INSTALL AN ADJUSTABLE TWO PIECE CAN AND INSTALL THE BOTTOM HALF PRIOR TO PAVING THE BITUMINOUS SHOULDER. IF THIS METHOD IS USED, THE TOP HALF SHALL BE INSTALLED BY CORING THROUGH THE BITUMINOUS PAVEMENT TO EXPOSE THE BOTTOM HALF.

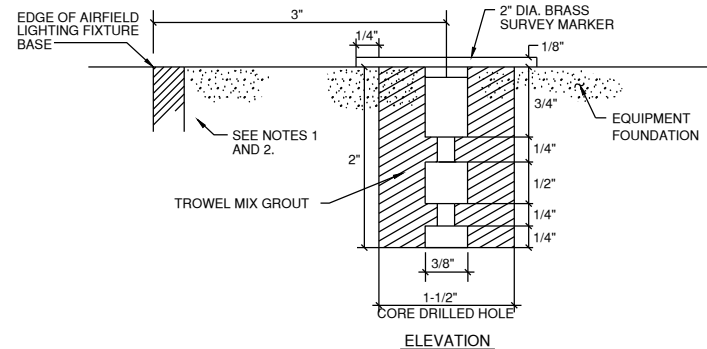

AIRFIELD LIGHTING FIXTURE IDENTIFICATION MARKER
N.T.S.

NOTES:

1. FOR IDENTIFICATION NUMBERS, SEE ELECTRICAL LAYOUT PLAN. CONTRACTOR SHALL VERIFY NUMBERING WITH AIRPORT PRIOR TO ORDERING MARKERS.
2. ALL AIRFIELD LIGHTING EQUIPMENT SHALL BE IDENTIFIED WITH A BRASS SURVEY MARKER. ITEMS REQUIRING ID MARKERS ARE:
JUNCTION BOXES
MANHOLES
TAXIWAY LIGHTS
3. L-823 CONNECTORS SHALL BE INSTALLED ON ALL CABLES, IN EACH MANHOLE, BASE CANS, OR OTHER ACCESSIBLE LOCATIONS. L-823 CONNECTORS SHALL BE INSTALLED SO A PORTION OF THE LOOP CAN BE BYPASSED.
4. ALL AIRFIELD LIGHTING CIRCUITS SHALL BE IDENTIFIED WITH A BRASS TAG WITH ITS RESPECTIVE CIRCUIT/LOOP NUMBER AT ALL ACCESSIBLE LOCATIONS. ATTACH THE ID TAG TO BOTH CABLES 12" FROM THE L-823 CONNECTORS.

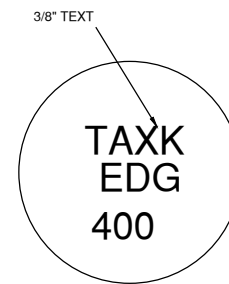

TOP VIEW AIRFIELD LIGHTING FIXTURE IDENTIFICATION MARKER
N.T.S.

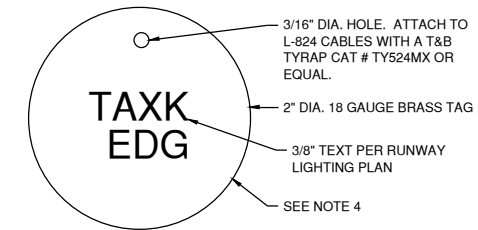

L-824 CABLE IDENTIFICATION TAG
N.T.S.

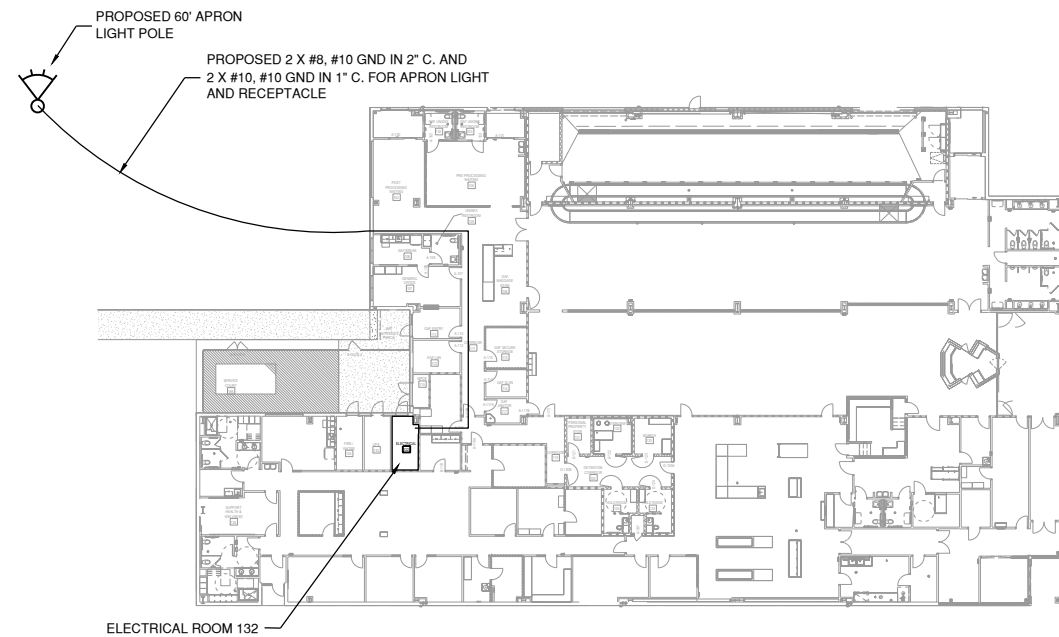

CBP BUILDING CONDUIT DETAIL
N.T.S.

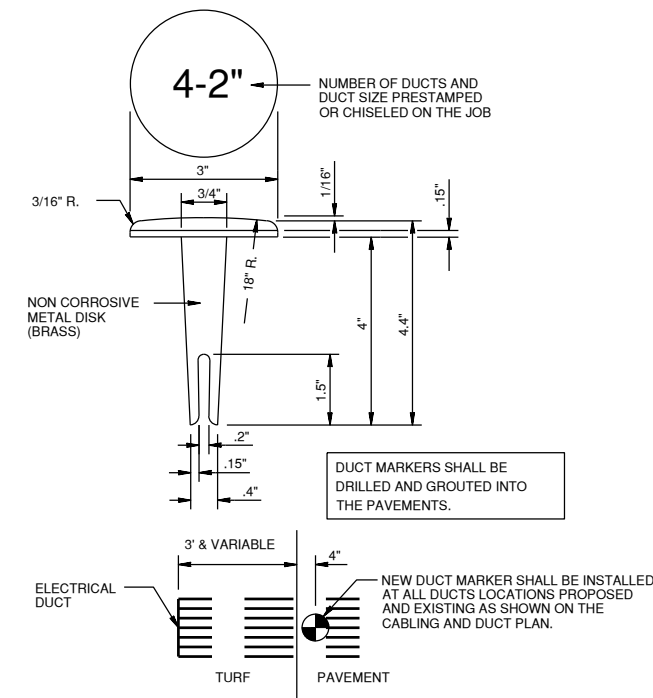

DUCT MARKER DETAIL
N.T.S.

100% SUBMITTAL
MARCH 1, 2024

TERMINAL APRON EXPANSION



MIDAMERICA
ST. LOUIS AIRPORT
ST. CLAIR COUNTY, IL

MARK	DATE	DESCRIPTION
BLV PROJECT NO.	2024-04	
IL PROJECT NO.	BLV-5101	
CMT PROJECT NO.	22001186.00	
CAD DWG FILE:	22001186 - EL500.DWG	
DESIGNED BY:	CMT	
DRAWN BY:	CMT	
CHECKED BY:	CMT	
APPROVED BY:	CMT	
COPYRIGHT: CRAWFORD, MURPHY & TILLY, INC. 2021		

ELECTRICAL DETAILS
1

100% SUBMITTAL
MARCH 1, 2024

TERMINAL APRON EXPANSION



MIDAMERICA
ST. LOUIS AIRPORT
ST. CLAIR COUNTY, IL

04/10/2024 ACCENDUM A

MARK	DATE	DESCRIPTION

BLV PROJECT NO. 2024-04

IL PROJECT NO. BLV-5101

CMT PROJECT NO: 22001186.00

CAD DWG FILE: 22001186 - EL500.DWG

DESIGNED BY: CMT

DRAWN BY: CMT

CHECKED BY: CMT

APPROVED BY: CMT

COPYRIGHT: CRAWFORD, MURPHY & TILLY, INC. 2021

SHEET TITLE

ELECTRICAL DETAILS

2

SHEET **55** OF **68**
EL502

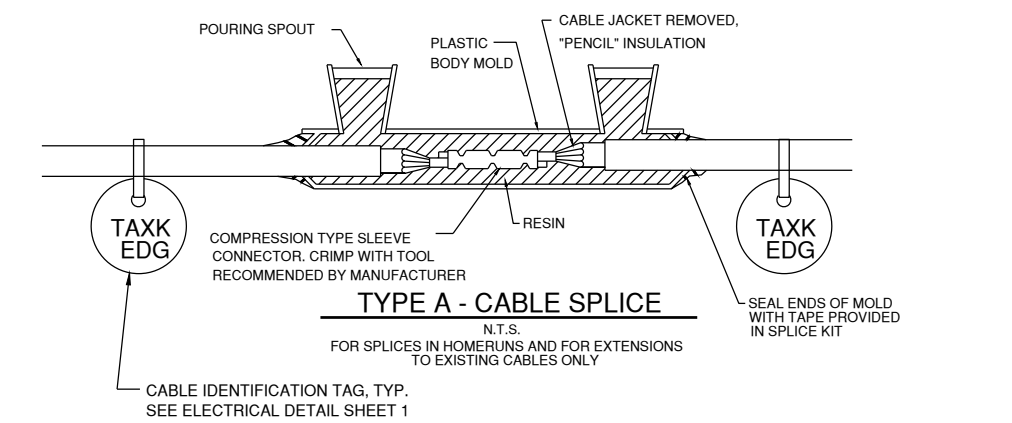

TYPE A - CABLE SPLICE
N.T.S.
FOR SPLICES IN HOMERUNS AND FOR EXTENSIONS TO EXISTING CABLES ONLY

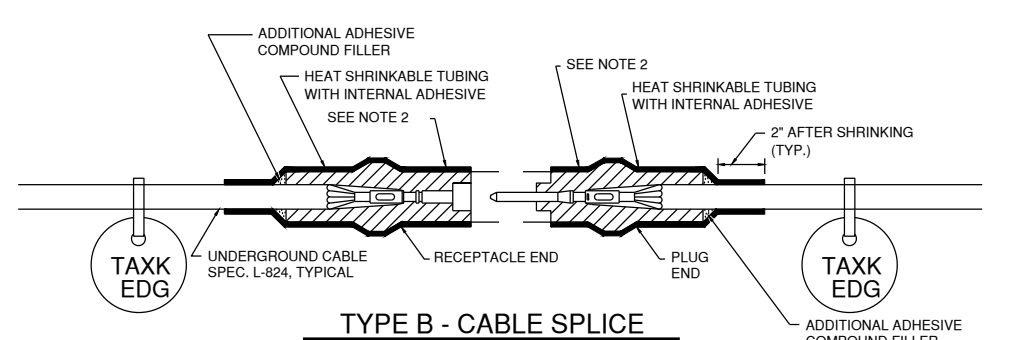

TYPE B - CABLE SPLICE
N.T.S.
FOR SPLICES FOR USE AT JUNCTION OF HOMERUN WITH LOOP CIRCUIT

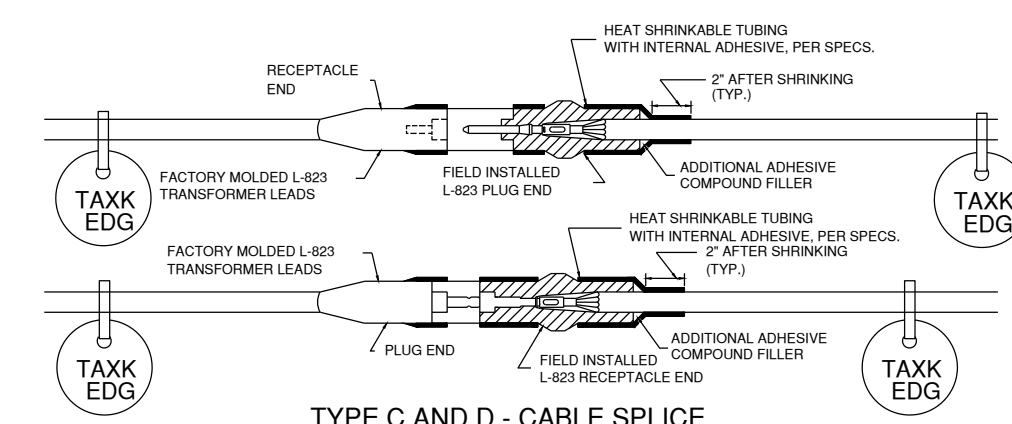

TYPE C AND D - CABLE SPLICE
N.T.S.
FOR SPLICES AT RUNWAY/TAXIWAY LIGHTS AND SIGNS

NOTES

- INSIDE DIAMETER OF CONNECTOR SHALL PROPERLY MATCH THE OUTSIDE DIAMETER OF CABLE.
- WRAP WITH AT LEAST ONE LAYER OF RUBBER OR SYNTHETIC RUBBER TAPE AND ONE LAYER OF PLASTIC TAPE, ONE-HALF LAPPED, EXTENDING AT LEAST 1-1/2 INCHES ON EACH SIDE OF JOINT.
- THE COST OF FURNISHING AND INSTALLING ALL SPLICE MATERIALS SHALL BE INCIDENTAL TO THE ASSOCIATED CABLE ITEMS.
- THE CONTRACTOR SHALL HAVE A MINIMUM OF TWO (2) TYPE A SPLICE KITS ON THE JOB SITE AT ALL TIMES FOR EMERGENCY REPAIRS.
- "COMPLETE KIT" SHALL BE ACCEPTABLE IN LIEU OF HEAT SHRINK.

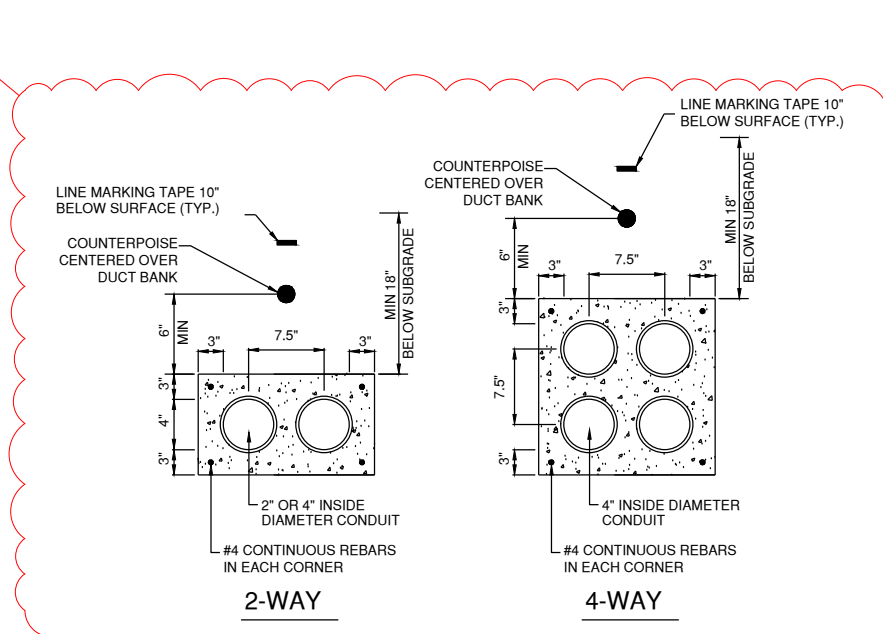

CONCRETE ENCASED DUCT BANKS
N.T.S.

NOTES:

- DIMENSIONS ARE MINIMUM.
- CONCRETE SHALL CONFORM TO ITEM 610.
- ALL CONDUIT SHALL BE SCHEDULE 40 PVC.
- TOP OF CONCRETE ENCASEMENT IN TURF AREAS SHALL NOT BE LESS THAN 24" BELOW FINISHED GRADE.
- SEE ELECTRICAL LAYOUT PLAN FOR CONDUIT DIAMETER.

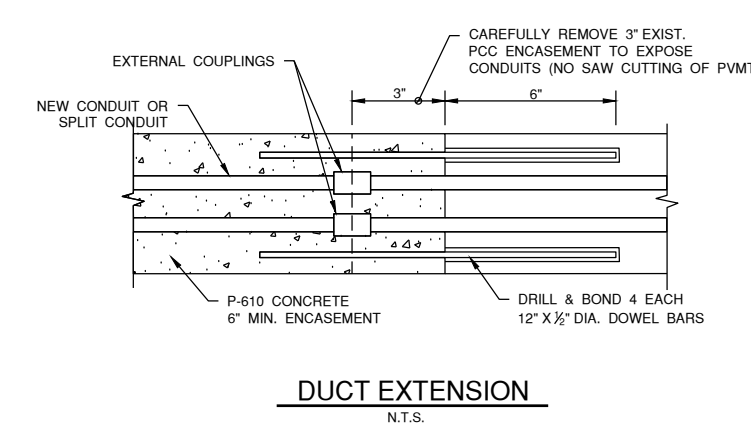

DUCT EXTENSION
N.T.S.

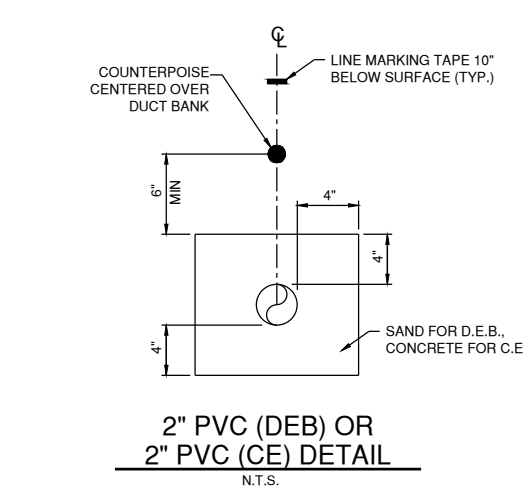

2" PVC (DEB) OR 2" PVC (CE) DETAIL
N.T.S.

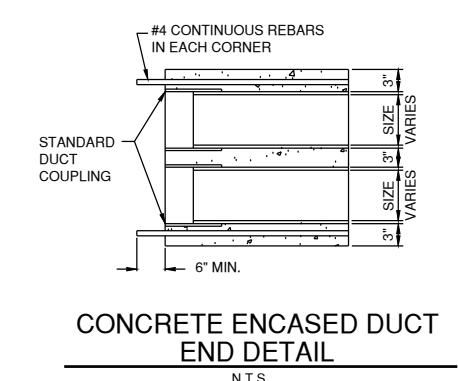

CONCRETE ENCASED DUCT END DETAIL
N.T.S.

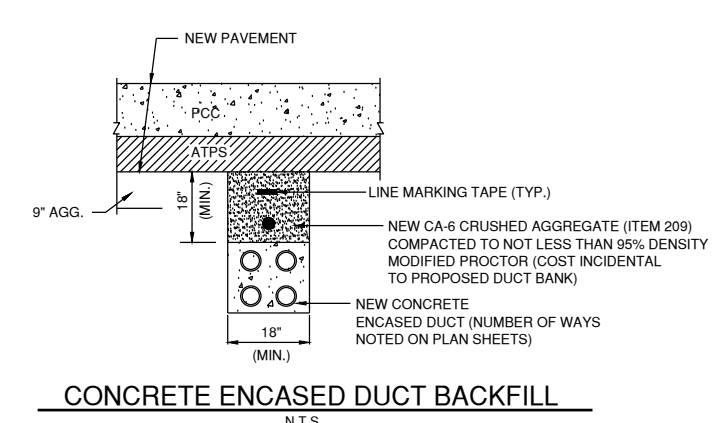

CONCRETE ENCASED DUCT BACKFILL
N.T.S.

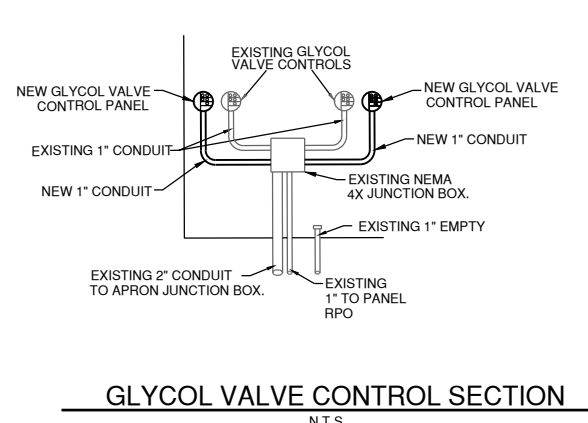

GLYCOL VALVE CONTROL SECTION
N.T.S.

Path: K:\MidAmerica\22001186-00_TerminalApronDraw\Sheets\22001186 - EL500.dwg
Date: Friday, April 12, 2024 11:41:35 PM

A

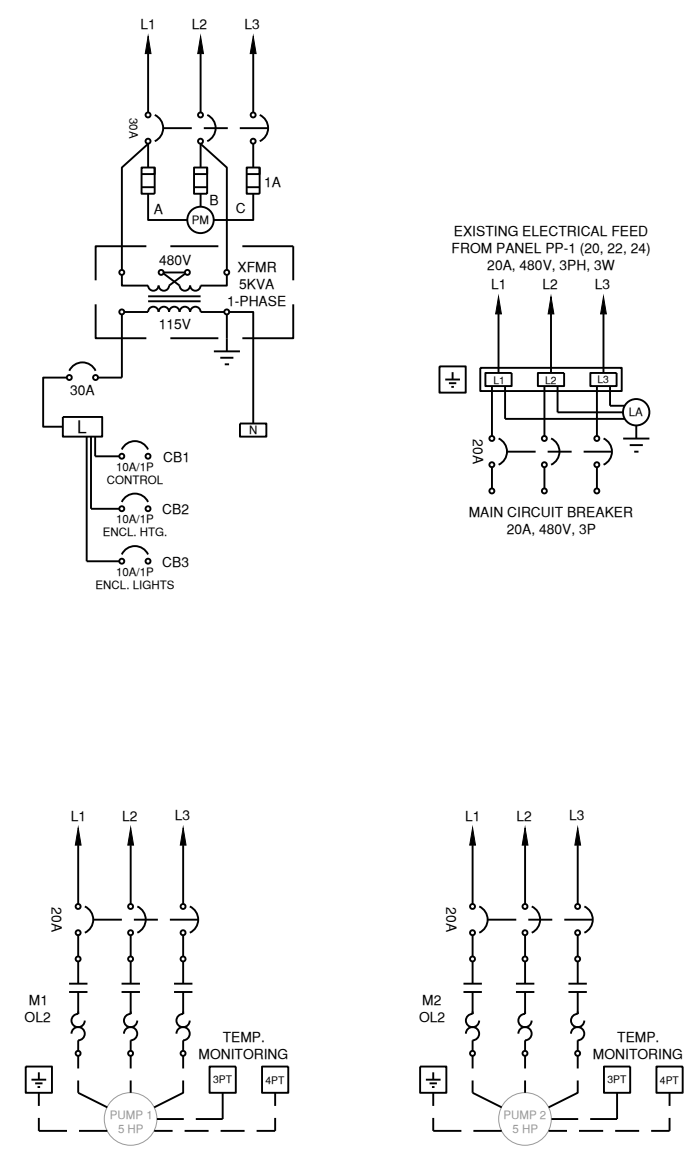
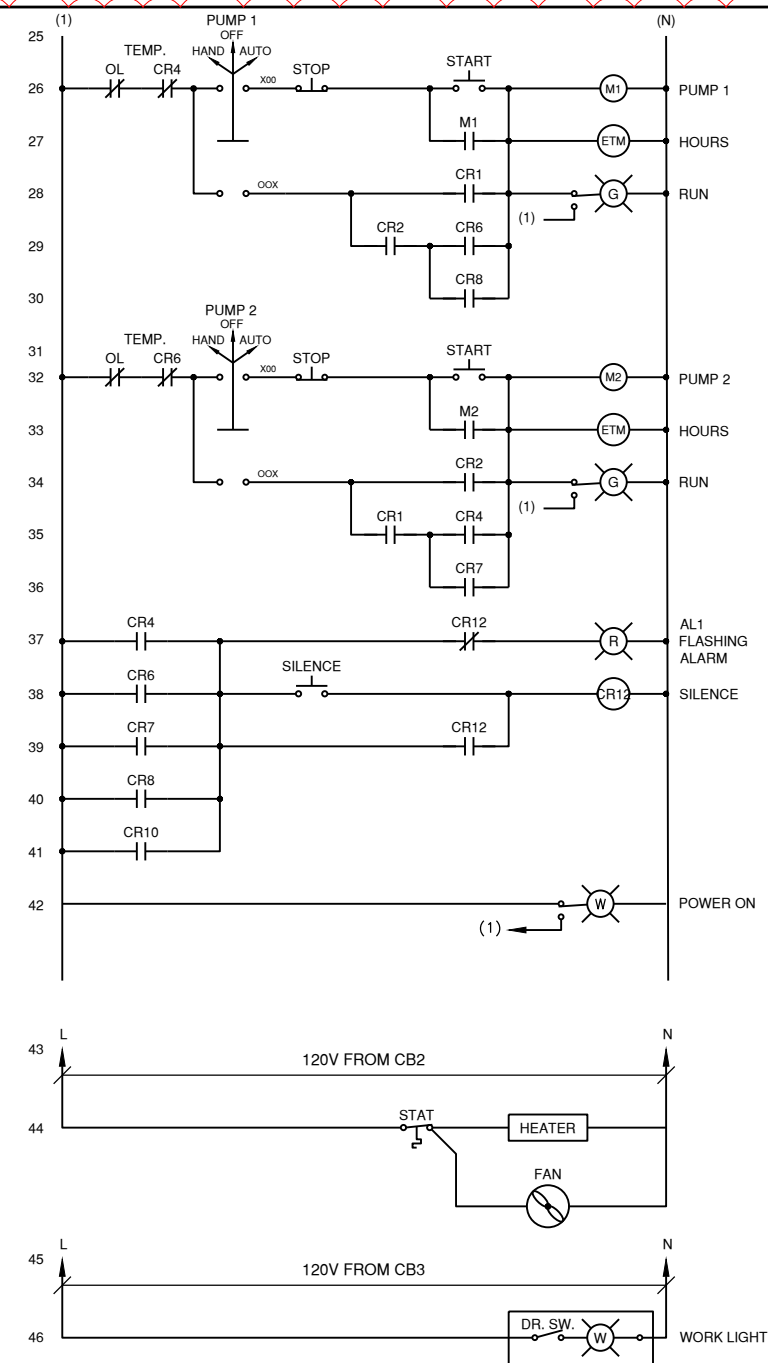
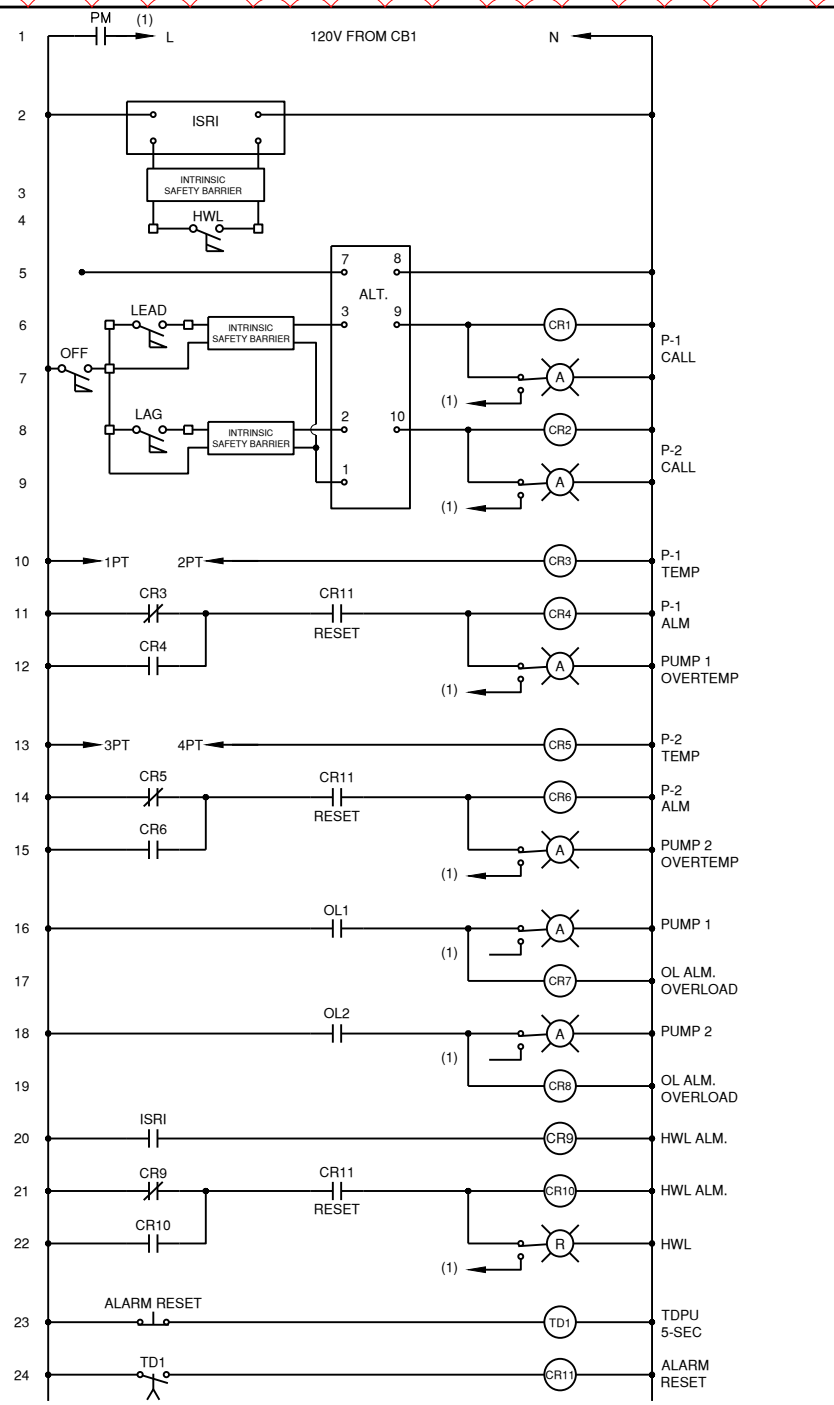

SCHEMATIC LEGEND

	NORMALLY OPEN (N.O.) RELAY CONTACT		3-POSITION SELECTOR SWITCH (H-O-A SHOWN)		N.C. } LIMIT SWITCHES
	NORMALLY CLOSE (N.C.) RELAY CONTACT		2-POSITION SELECTOR SWITCH		N.O. } PROXIMITY SWITCHES
	STARTER COIL, * = STARTER NUMBER		N.C. (STOP) N.O. (START) } PUSHBUTTONS		N.C. } PRESSURE SWITCHES
	OVERLOAD RELAY CONTACT		N.O. } LEVEL SWITCHES		N.O. } THERMAL SWITCHES
	CONTROL RELAY, * = CONTROL RELAY NUMBER		N.C. } FLOW SWITCHES		RTM RUN TIME METER, HOUR METER
	TIME DELAY RELAY, * = DEVICE NUMBER, ** = TIME SETTING				CIRCUIT BREAKER
	CLOSED SWITCH WITH TIME DELAY OPENING				FUSE
	OPEN SWITCH WITH TIME DELAY CLOSING				INTERNAL PANEL WIRING OR DEVICES
	CLOSED SWITCH WITH TIME DELAY CLOSING				FIELD WIRING OR DEVICES
	OPEN SWITCH WITH TIME DELAY OPENING				
	PILOT LIGHT, (P) = LETTER DENOTING COLOR, E.G. R=RED, G=GREEN, A=AMBER, W=WHITE				
	HORN				
	SOLENOID VALVE, * = SOLENOID VALVE NUMBER				



License No. 184-000613
CONSULTANTS

100% SUBMITTAL
MARCH 1, 2024

TERMINAL APRON EXPANSION



MIDAMERICA
ST. LOUIS AIRPORT
ST. CLAIR COUNTY, IL

MARK	DATE	DESCRIPTION
		BLV PROJECT NO. 2024-04
		IL PROJECT NO. BLV-5101
		CMT PROJECT NO: 22001186.00
		CAD DWG FILE: 22001186 - EL500.DWG
		DESIGNED BY: CMT
		DRAWN BY: CMT
		CHECKED BY: CMT
		APPROVED BY: CMT
		COPYRIGHT: CRAWFORD, MURPHY & TILLY, INC. 2021
SHEET TITLE		
ELECTRICAL DETAILS		
7		

Path: K:\MidAmerica\22001186-00_TerminalApron\Draw\Sheets\22001186 - EL500.dwg
Date: 2/28/2024 11:43:49 AM

100% SUBMITTAL
MARCH 1, 2024

TERMINAL APRON EXPANSION



MIDAMERICA
ST. LOUIS AIRPORT
ST. CLAIR COUNTY, IL

MARK	DATE	DESCRIPTION
	04/18/2024	ADDENDUM A

MARK	DATE	DESCRIPTION
		BLV PROJECT NO. 2024-04
		IL PROJECT NO. BLV-5101
		CMT PROJECT NO: 22001186.00
		CAD DWG FILE: 22001186 - EL500.DWG
		DESIGNED BY: CMT
		DRAWN BY: CMT
		CHECKED BY: CMT
		APPROVED BY: CMT
		COPYRIGHT: CRAWFORD, MURPHY & TILLY, INC. 2021

SHEET TITLE

ELECTRICAL DETAILS

8

EL508

SHEET 59B OF 68

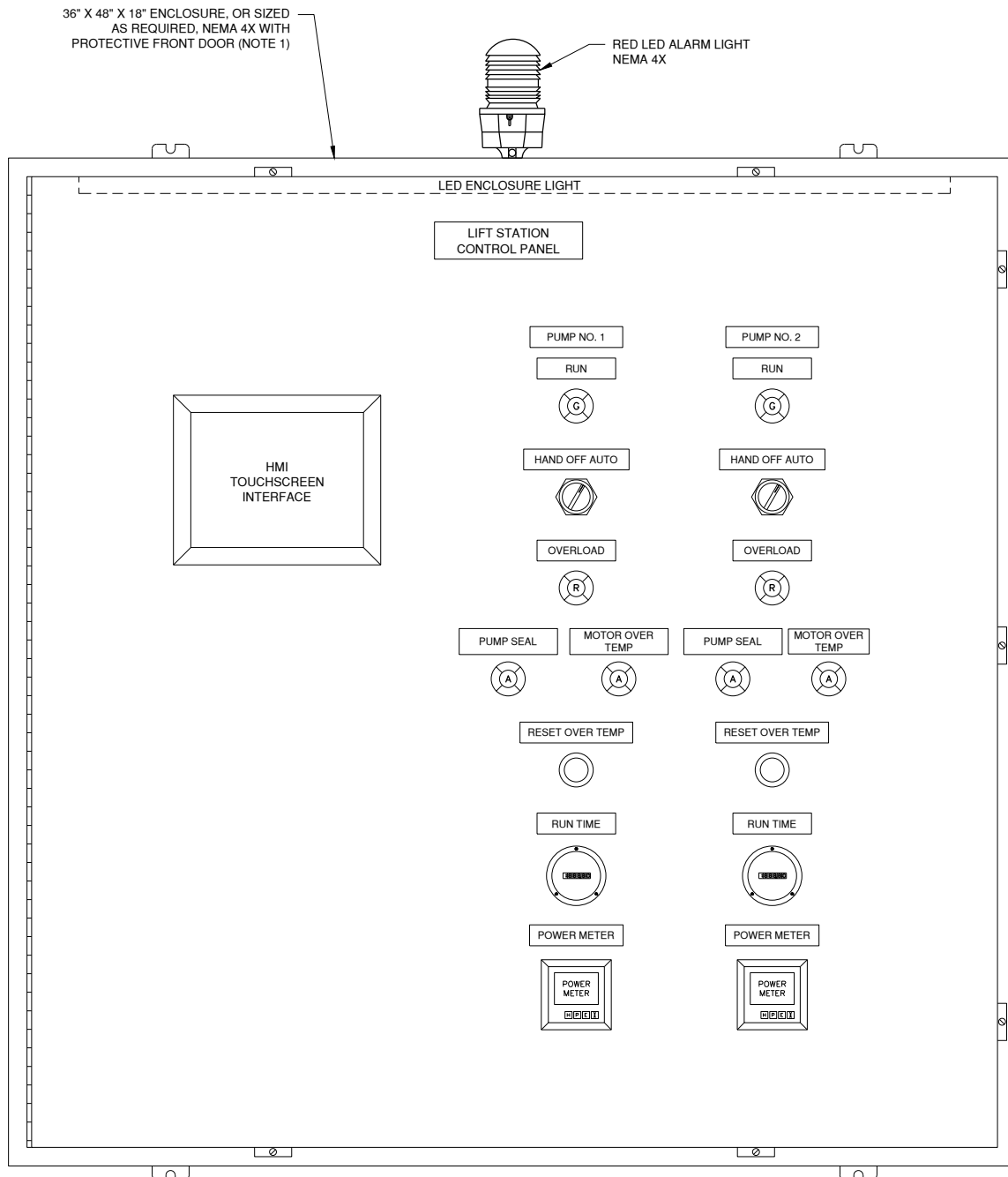

LIFT STATION CONTROL CABINET ELEVATION

N.T.S.

NOTES:

- ENCLOSURE SIZE SHALL BE DETERMINED BY LIFT STATION CONTROLLER MANUFACTURER AS REQUIRED FOR ALL COMPONENTS.
- INSTALL FIBER OPTIC PATCH PANEL INSIDE ENCLOSURE.
- PROVIDE COMMUNICATION MODULE FOR ALARM NOTIFICATION TO EXISTING BMS VIA FIBER OPTIC.

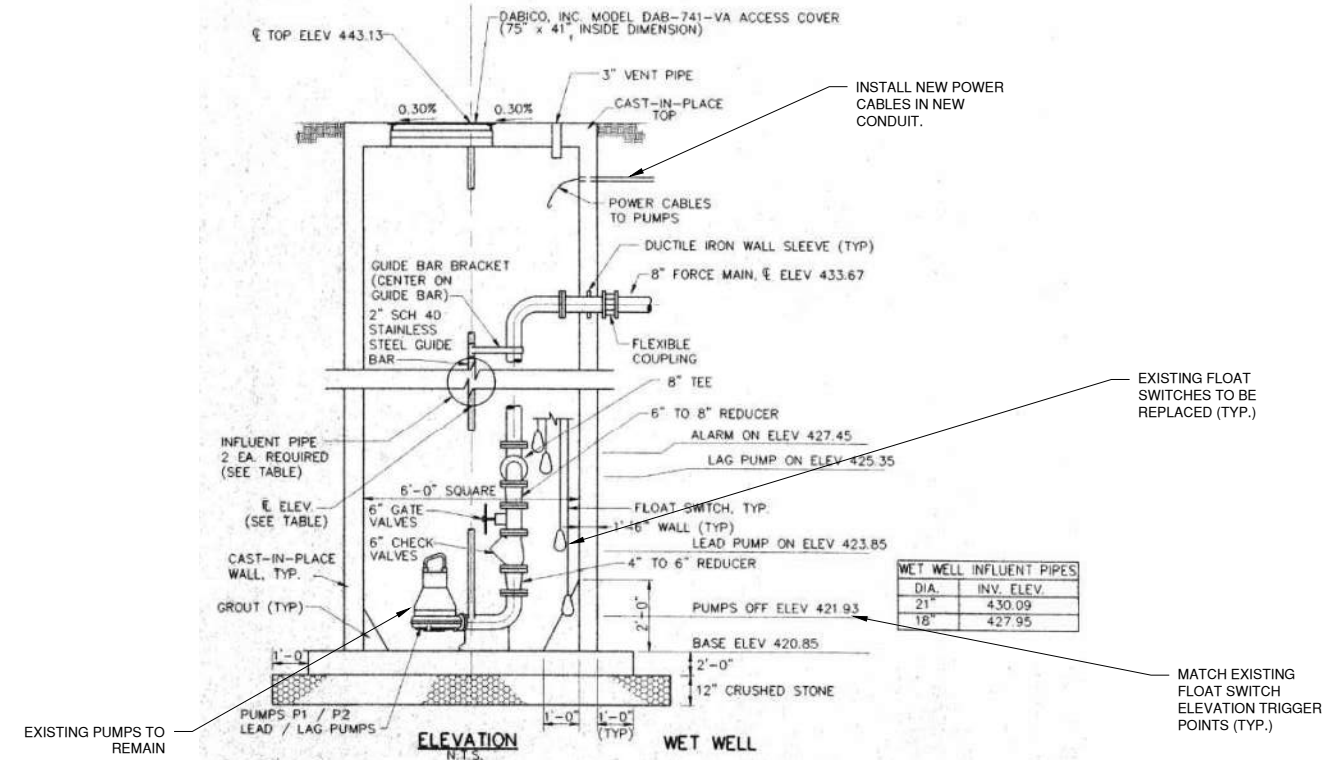

EXISTING LIFT STATION WET WELL ELEVATION

N.T.S.

NOTE: INSTALL NEW FLOATS AND LEVEL TRANSDUCER.

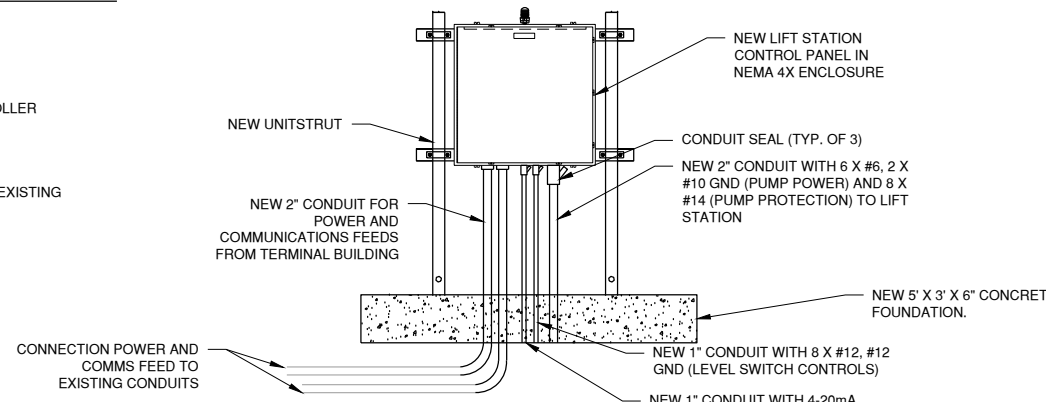

LIFT STATION CONTROLLER PEDESTAL ELEVATION

N.T.S.

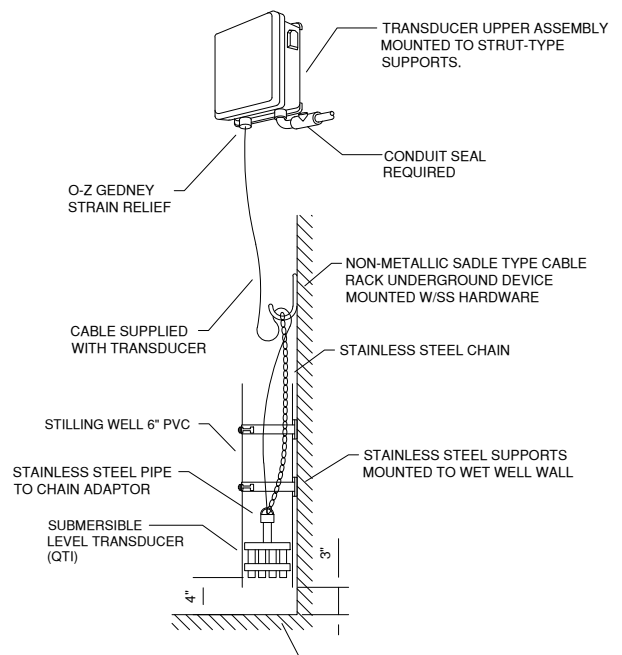

PROPOSED SUBMERSIBLE LEVEL TRANSDUCER DETAIL

N.T.S.

ADDENDUM A TECHNICAL SPECIFICATION REVISIONS

TERMINAL APRON EXPANSION – PROJECT 1

TECHNICAL SPECIFICATIONS

PART 1 General Contract Provisions

Section 10 – 90 Modifications to FAA General Contract Provision.....	1
--	---

PART 2 – General Construction Items

Item C-100 Contractor Quality Control Program (CQCP)	50
Item C-102 Temporary Air and Water Pollution, Soil Erosion and Siltation Control	57
Item C-105 Mobilization.....	62
Item C-110 Method of Estimating the Percentage of Material	65

PART 3 - Sitework

Item P-101 Preparation/Removal of Existing Pavements	72
Item P-152 Excavation, Subgrade and Embankment	76
Item P-155 Lime Treated Subgrade.....	85

PART 4 - BASE COURSES

Item P-209 Aggregate Base Course.....	91
---------------------------------------	----

PART 6 – FLEXIBLE PAVEMENT

Item P-401 Asphalt Mix Pavement	98
Item P-407 Asphalt Treated Permeable Base Course.....	117

PART 7 - RIGID PAVEMENT

Item P-501 Cement Concrete Pavement.....	124
--	-----

PART 9 - MISCELLANEOUS

Item P-602 Emulsified Asphalt Prime Coat	159
Item P-603 Emulsified Asphalt Tack Coat.....	162
Item P-604 Compression Joint Seals for Concrete Pavements.....	166
Item P-610 Concrete for Miscellaneous Structures	171
Item P-620 Runway and Taxiway Marking.....	177

PART 10 – FENCING

Item F-162 Chain Link Fence.....	183
----------------------------------	-----

PART 11 - DRAINAGE

Item D-701 Pipe for Storm Drains and Culverts	189
Item D-705 Pipe Underdrains for Airports.....	197
Item D-751 Manholes, Catch Basins, Inlets, and Inspection Holes	205

Item D-752	Concrete Culverts, Headwalls, and Miscellaneous Drainage Structures	210
Item D-754	Concrete Gutters, Ditches, and Flumes.....	213

PART 12 - TURFING

Item T-901	Seeding	215
Item T-904	Sodding	222
Item T-908	Mulching.....	227

PART 13 - LIGHTING INSTALLATION

Item L-108	Underground Power Cable for Airports.....	230
Item L-110	Airport Underground Electrical Duct Banks and Conduits	242
Item L-125	Installation of Airport Lighting Systems	250

PART 14 - SPECIAL PROVISIONS

SP-1	Apron Lighting	255
SP-2	Basin Spillway Modifications.....	261
SP-3	Sanitary Sewer System	264
SP-4	Sanitary Manholes and Covers	270
SP-5	Power Distribution.....	274
SP-6	Sanitary Forcement System	283
SP-7	New Vehicle Sign	287
SP-8	Valves & Actuators.....	289
SP-9	BLV Badge Requirements	299
SP-10	Temporary Access Roads	303
SP-11	Repair Haul Route #2	305
SP-12	Glycol Control Panel	307
SP-13	General Electrical Requirements	320

ITEM C-105 MOBILIZATION

105-1 Description. This item of work shall consist of, but is not limited to, work and operations necessary for the movement of personnel, equipment, material and supplies to and from the project site for work on the project except as provided in the contract as separate pay items. The Engineer's Field Office is also included in this item of work.

105-2 Mobilization limit. Mobilization shall be limited to ten (10%) percent of the total project cost. Claims for payment that exceed ten (10%) percent shall be released proportional to the percentage of contract complete.

105-3 Posted notices. Prior to commencement of construction activities, the Contractor must post the following documents in a prominent and accessible place where they may be easily viewed by all employees of the prime Contractor and by all employees of subcontractors engaged by the prime Contractor: Equal Employment Opportunity (EEO) Poster "Equal Employment Opportunity is the Law" in accordance with the Office of Federal Contract Compliance Programs Executive Order 11246, as amended; Davis Bacon Wage Poster (WH 1321) - DOL "Notice to All Employees" Poster; and Applicable Davis-Bacon Wage Rate Determination. These notices must remain posted until final acceptance of the work by the Owner.

In addition, the Contractor shall conform to State of Illinois requirements for posters, which can be found on the IDOT website. The Contractor is solely responsible for keeping the bulletin board current and in conformance with local, state, and federal requirements.

The Owner, for the benefit of the Contractor, may include additional posted notices as required by local and State law. Links to the posters available at: <https://www.faa.gov/airports/engineering/>

105-4 Engineer/RPR field office.

This item shall consist of furnishing and maintaining in good condition for the exclusive use of the RPR, a weatherproof building hereinafter described at locations approved by the MidAmerica St. Louis Airport and RPR. The building shall be independent of any building used by the Contractor, and all keys to the building shall be turned over to the RPR. The facility shall remain on the work site until released by Substantial Completion.

Field offices shall have a minimum ceiling height of seven feet and a minimum floor space of 240 square feet. The office shall be provided with sufficient natural and artificial light and air conditioning. Doors and windows shall be equipped with locks approved by the RPR.

Suitable on-site sanitary facilities meeting Federal, State, and local health department requirements shall be provided, maintained clean and in good working condition, and shall be stocked with lavatory and sanitary supplies at all times.

The building will include all utility costs and shall be released to the Contractor in good condition at the end of the project. In addition, the following equipment and furniture meeting the approval of the RPR shall be furnished:

- a. Two desks and two non-folding chairs with upholstered seats and backs.
- b. One free standing four drawer legal size file cabinets with lock and an Underwriters' Laboratories insulated file device 350 degrees one hour rating.

- c. One dry process copy, print, & scan machine (including maintenance and operating supplies) capable of both collating and reproducing prints up to a ledger size (11” x 17”) and capable of copying and scanning in color.
- d. One refrigerator with a minimum size of 8 cubic feet with a freezer unit.
- e. One electric desk tape calculator and adding machine with tape or one tape printing calculator
- f. One mobile wireless network with a cost-free connection to the internet to be used in the RPR field office, and one to be used on the construction site for use by the RPR. Possible solutions include wireless network cards installed in the RPR’s computer or wireless phones capable of supplying access to the internet via a mobile connection. The network shall be available to the RPR until Substantial Completion.
- g. Additional Furnishings shall include:
 - a. Six lineal feet of bookshelves.
 - b. Six straight chairs.
 - c. One wastebasket.
 - d. One tack board, 36 inches x 30 inches.
 - e. Fire extinguishers: One standard dry chemical (ABC) typer for each office

105-5 Construction Access. This item shall consist of providing adequate access to the work area for use during construction. Access shall be constructed and maintained throughout construction in a manner that will provide all-weather access to the work areas. Costs associated with maintenance shall be considered incidental to the mobilization pay item.

Temporary gates will be installed as needed at locations shown in the plans or as directed by the RPR. Temporary gates are paid for under item F-161.

105-6 Restore Construction Access. This item shall consist of the restoration of areas disturbed for construction access to their pre-construction condition. Restored area shall be seeded and mulched in conformance with Sections T-901 and T-908. Grading, seeding and mulching shall be considered incidental to the contract.

Temporary gates shall be removed, and the original fencing restored as requested by the RPR. Costs associated with temporary gate removals and fence restoration shall be paid for under Item F-161.

105-7 Traffic Maintenance. This item shall consist of the placement, maintenance and adjustment of barricades and other devices as shown in the plans or as directed by the RPR.

Payment for the Engineer’s Field Office will be based on the installation and equipping of the field office in accordance with these specifications.

105-8 Road Use Agreement. Before mobilization, the Contractor shall enter into a Road Use Agreement with the Road District in St Clair County, Illinois. The costs associated with the road use agreement shall be incidental to the Contract.

METHOD OF MEASUREMENT

105-5.1 RPR Field Office. The RPRs field office shall be measured by lump sum, meeting all the requirements herein, maintained, and accepted as compliant with these documents.

The Engineer’s Field Office pay item shall not include the costs for any other incidentals to the contract, such as mobilization, supervision, surveying, security, testing, administration, QA/QC, or traffic control.

105-5.2 Mobilization basis of measurement and payment.

Based upon the contract lump sum price for “Mobilization,” partial payments will be allowed as follows:

- a. With the first pay request, 25%.
- b. When 25% or more of the original contract is earned, an additional 25%.
- c. When 50% or more of the original contract is earned, an additional 40%.
- d. After Final Inspection, staging area clean-up and delivery of all Project Closeout materials as required by Section 90, paragraph 90-11, *Contractor Final Project Documentation*, the final 10%.

Re-mobilization due to suspension of calendar days will not be paid for.

BASIS OF PAYMENT

105-6 Payment. Payment shall be made at the contract unit price for the unit of measurement as specified above. [Re-mobilization due to suspension of calendar days will not be paid for.](#)

These prices shall be full compensation for furnishing all materials and for all preparation, hauling, and placing of the material, and for all labor, equipment, tools, and incidentals necessary to complete this item.

Payment will be made under:

Item AW150510 Engineer’s Field Office – per lump sum

Item AW150520 Mobilization - per lump sum.

REFERENCES

The publications listed below form a part of this specification to the extent referenced. The publications are referred to within the text by the basic designation only.

Office of Federal Contract Compliance Programs (OFCCP)

Executive Order 11246, as amended

EEOC-P/E-1 – Equal Employment Opportunity is the Law Poster

United States Department of Labor, Wage and Hour Division (WHD)

WH 1321 – Employee Rights under the Davis-Bacon Act Poster

END OF ITEM C-105

Item SP-5 Power Distribution

Description

1-1.1 General. This item shall consist of furnishing and installing power distribution equipment as detailed on the plans and specified herein.

1-1.2 This Item shall include furnishing and installing a new utility metered service, low voltage panelboards, transformer, disconnect, strut type framing, grounding conductors, and wiring as necessary for a complete and accepted unit.

Materials and Parts

1-2.1 Grounding and Bonding. Ground rods shall be UL listed, single-piece, 3/4" diameter by 10' long copper-clad steel with minimum 10 mil copper cladding. All buried connections of grounding and bonding components shall be via exothermic weld only. Clamp or compression grounding connections below grade will be rejected and replaced at Contractor's expense. Grounding conductors shall be 600-volt, same insulation type as used for phase conductors, green in color unless otherwise noted. Grounding electrode conductors in contact to earth shall be bare, stranded, annealed copper. Grounding Electrode Conductors shall be the larger of that detailed on the project drawings, specified herein or as required by NEC.

1-2.2 Service Entrance. Contractor shall coordinate new utility electric service with utility company.

Serving Utility shall furnish and install:

1. Medium-Voltage primary cable, installation, and terminations.
2. Service transformer
3. All metering transformers (C.T.'s and P.T.'s as appropriate). (Note, Contractor shall furnish and install metering transformer cabinet if not furnished by serving Utility.)
4. Termination of secondary conductors on secondary lugs of pad-mount transformer. Conductors to be provided and pulled by Contractor.
5. KWH Meter instrument. (Note, Contractor shall furnish and install kWH Meter Base if not furnished by serving Utility.)
6. Installation of secondary metering conductors between metering transformer enclosure and KWH meter equipment. Conduit and pull string meeting utility requirements is to be provided and installed by Contractor.

Contractor shall furnish and install:

1. Concrete transformer pad with frost-legs meeting utility details and specification requirements.
2. Secondary service conductors and conduit between pad-mount transformer and Metering Transformer Cabinet.
3. Termination of service conductors at Metering Transformer Cabinet. Service conductors will be terminated at utility pad-mount transformer by serving utility.
4. If not furnished by serving Utility, KWH Meter Base meeting electric utility requirements
5. If not furnished by serving Utility, Metering Transformer Cabinet meeting electric utility requirements.
6. Conduit and pull-string meeting utility requirements between Metering Transformer Cabinet and KWH Meter base. Electric utility will furnish and install metering conductors.
7. Installation of conduit and service conductors between Metering Cabinet and Service Entrance Main Disconnect.

8. Any additional work as required by serving utility but not specifically noted herein shall be considered incidental to this section.
9. Grounding and Bonding for Service Entrance is covered under Grounding and Bonding.

Contractor shall comply with all requirements of serving utility. Contractor shall coordinate service installation with serving utility. Cable and appurtenances shall be warranted to be free from defects in material and workmanship for a period of one year from date of substantial completion.

CONTRACTOR SHALL NOTE THAT ALL “NEW SERVICE” OR “ONE TIME CHARGES” THAT MAY BE BILLED BY THE SERVING UTILITY SHALL BE PAID FOR BY THE CONTRACTOR AND INCLUDED WITH THE BASE BID PRICE UNDER THIS ITEM. THEY WILL NOT BE PAID FOR SEPARATELY.

~~COSTS FROM SERVING UTILITY THAT MAY BE CHARGED FOR PROVIDING NEW PERMANENT ELECTRICAL SERVICE TO THE FACILITY WILL BE PAID BY THE OWNER. CONTRACTOR SHOULD NOT INCLUDE THESE IN HIS BASE BID COST.~~

1-2.3 Supports and Foundation. The supports and foundation for the electrical equipment shall be as shown on the plans. The concrete for the support foundations and pad shall meet the requirements of Item P-610. Reinforcing steel shall be as shown in the plans.

Stored conduit and equipment supports shall not be in contact with earth, but shall be on pallets or other above-grade supports. Conduit and equipment supports shall be covered to minimize exposure to weather. Anchors and fasteners shall be stored in their original containers in a clean, dry place. They shall not be exposed to the weather.

1-2.3 Strut-Type Framing. Where utilized, strut-type metal framing shall be provided to mount and support electrical equipment and enclosures as indicated on the drawings. Strut-type supports shall be either aluminum or stainless-steel construction. Unless specifically identified for use on the drawings, painted or factory coated steel, galvanized steel or non-metallic strut are not acceptable alternates to this requirement. Use stainless steel on all project locations where strut is in direct physical contact with earth. Unless specifically noted to be Type 316 Stainless Steel only, Stainless Steel strut-type metal framing may be Type 304 or Type 316 Stainless Steel. Aluminum strut-type metal framing shall be Type 6063-T6 Aluminum. All mounting hardware shall be stainless steel.

1-2.4 Distribution Panelboard (DP-1).

Distribution panelboard shall be 30-Ckt, 200A, 480Y/277V, 3-phase, 4-wire, with 200A, 3P main circuit breaker, in NEMA 3R enclosure, Square D type NF, or equivalent. Provide feeder circuit breakers as indicated in Panelboard Schedule on the plans. Provide engraved nameplate reading “DP-1, 200A, 480/277V, 3PH”.

Panelboard shall be provided with bolt-on circuit breakers of size and rating as detailed in panelboard schedule on plans. Breakers shall be 1, 2 or 3-pole with an integral crossbar to assure simultaneous opening of all poles in multipole circuit breakers. Breakers shall have an overcenter, trip-free, toggle-type operating mechanism with quick-make, quick-break action, and positive handle indication. Handles shall have "ON", "OFF" and "TRIPPED" positions. Circuit breakers shall be UL listed in accordance with UL Standard 489.

Panelboards bus structure and main lugs or main circuit breakers shall have current ratings as shown on panelboard schedule. Bus material shall be copper with either silver or tin plating. Bus ratings shall be in

accordance with UL Standard 67. Bus bar connections to branch circuit breakers shall be the "distributed phase" or phase sequence type.

Panelboard bus assembly shall be enclosed in a steel cabinet rated NEMA 3R (unless otherwise noted on the drawings). Box front shall include a door and have a flush, cylinder tumbler-type lock and catch and spring-loaded stainless-steel door pull. Door shall have completely concealed hinges when closed and shall not be removable when locked. A circuit directory frame and card with a clear plastic cover shall be provided on door interior.

Panelboards shall be nominal 20" in width unless otherwise noted.

Panelboards rated 480 VAC and shall have short-circuit ratings as shown on the drawings, or as herein scheduled, but not less than an integrated equipment rating of 42,000 amps RMS symmetrical. All units shall bear UL label.

Except where noted otherwise on the drawings, all panelboards shall have neutral bar and ground bar bonded together. Where neutral bar and ground bar are noted to be isolated, the contractor shall verify during wiring installation that neutral and ground conductors are terminated on the correct bar.

Where schedule on drawings indicates "SPARE", a complete circuit breaker of the ampacity and number of poles indicated is to be provided. Where schedule on drawings does not indicate a specific size circuit breaker provide a 20 AMP single pole circuit breaker for each of the remaining unused poles. Therefore, panelboard shall be filled with feeder circuit breakers.

1-2.5 Power Panelboard (PP-1). Power panelboard shall be 30-Ckt, 200A, 208Y/120V, 3-phase, 4-wire, with 200A, 2P main circuit breaker, in NEMA 3R enclosure, Square D type NF, or equivalent. Provide feeder circuit breakers as indicated in Panelboard Schedule on plans. Provide engraved nameplate reading "PP-1, 200A, 208Y/120V".

Panelboard shall be provided with bolt-on circuit breakers of size and rating as detailed in panel schedule on plans. Breakers shall be 1, 2 or 3-pole with an integral crossbar to assure simultaneous opening of all poles in multipole circuit breakers. Breakers shall have an overcenter, trip-free, toggle-type operating mechanism with quick-make, quick-break action, and positive handle indication. Handles shall have "ON", "OFF" and "TRIPPED" positions. Circuit breakers shall be UL listed in accordance with UL Standard 489.

Panelboards bus structure and main lugs or main circuit breakers shall have current ratings as shown on panelboard schedule. Bus material shall be copper with either silver or tin plating. Bus ratings shall be in accordance with UL Standard 67. Bus bar connections to branch circuit breakers shall be the "distributed phase" or phase sequence type.

Panelboard bus assembly shall be enclosed in a steel cabinet rated NEMA 3R (unless otherwise noted on the drawings). Box front shall include a door and have a flush, cylinder tumbler-type lock and catch and spring-loaded stainless-steel door pull. Door shall have completely concealed hinges when closed and shall not be removable when locked. A circuit directory frame and card with a clear plastic cover shall be provided on door interior.

Panelboards shall be nominal 20" in width unless otherwise noted.

Panelboards rated 208 VAC shall have short-circuit ratings as shown on the drawings, or as herein scheduled, but not less than an integrated equipment rating of 22,000 amps RMS symmetrical. All units shall bear UL label.

Except where noted otherwise on the drawings, all panelboards shall have neutral bar and ground bar bonded together. Where neutral bar and ground bar are noted to be isolated, the contractor shall verify during wiring installation that neutral and ground conductors are terminated on the correct bar.

Where schedule on drawings indicates “SPARE”, a complete circuit breaker of the ampacity and number of poles indicated is to be provided. Where schedule on drawings does not indicate a specific size circuit breaker provide a 20 AMP single pole circuit breaker for each of the remaining unused poles. Therefore, panelboard shall be filled with feeder circuit breakers.

1-2.6 Dry Type Transformer. Dry type transformers shall be manufactured and supplied by a company regularly engaged in business of furnishing dry type transformers. If required by Owner’s representative, manufacturer shall submit a certification to a minimum experience of ten years in manufacture of dry type transformers. All equipment shall be warranted to be free from defects in material and workmanship for a period of one year from date of substantial completion established by the Owner.

1-2.7 Disconnect Switches. Safety switches (disconnects) shall be rated for use at 480 Volts, 3 phase and shall be Heavy Duty, NEMA KS 1 load interrupter enclosed knife switch with externally operated handle interlocked to prevent opening front cover with switch in ON position. Disconnect handle shall be lockable in ON or OFF position. Safety switch enclosures shall be NEMA 3R, unless otherwise indicated on drawings. Disconnects shall be non-fusible type. Where noted, disconnects shall be U.L. Listed as suitable for use as Service Entrance Disconnect Equipment. Provide Ground Kit and Neutral Kit where required.

1-2.8 Receptacle Pedestals. Receptacle Pedestals shall be as shown on the plans and as detailed herein. Posts shall be 3-inch galvanized rigid steel post with post cap. Post concrete foundation shall be per specification item P-610. Posts shall contain one (1) 208VAC single-phase Receptacle in weatherproof enclosure and one (1) 120VAC duplex GFCI receptacle in weatherproof enclosure. 208V receptacles shall be UL Weather-Resistant receptacle 30-amp, 208-volts, 3-wire grounding type, NEMA 10, back and side wire compatible. 120V Receptacles shall be UL Weather-Resistant GFCI receptacle 20-amp, 125-volts, 3-wire grounding type, NEMA 5-20R, back and side wire compatible. Include indicator light that is lighted when device is tripped. Self-test feature to conduct an automatic test every three seconds, ensuring ground protection. If ground fault protection is comprised, power to the receptacle must be discontinued. All receptacle covers shall comply with NEC Article 406.9B1. Units shall remain raintight whether or not a plug and cord is inserted. Covers shall be extra-deep, padlock able, cast aluminum construction, listed, and identified as “extra duty” as manufactured by Intermatic WP1010HMXD, Hubbell, WP26EH, Pass & Seymour CA26WV or equivalent, horizontal, for use with GFCI receptacles. Where galvanized rigid metal conduit is used, associated device boxes shall be FS or FD design, metallic, as manufactured by Crouse-Hinds, or equivalent.

1-2.9 Surge Suppressor. Surge protection equipment shall be furnished with new Distribution Panelboard (DP-1). Indicate application conditions and limitations of use stipulated by Product testing agency specified under Regulatory Requirements. Include instructions for storage, handling, protection, examination, preparation and installation of Product. Third party tested for compliance. Conform to requirements of ANSI/NFPA 70. Furnish products listed and classified by Underwriters Laboratories, Inc., as suitable for purpose specified and shown. Electrical Surge Protection hardware shall be U.L. Listed and labeled as “Surge Protective Devices” under the latest edition of UL 1449 “3rd Edition”.

Visual indication that surge suppressors are functioning properly shall be furnished in the form of display, pilot light or LED for each device. If manufacturer utilizes LED's or pilot lights, one indicator shall be provided for each leg of a multi-phase device. Where Surge Protective hardware is not an integral part of a factory-assembled piece of equipment (such as factory installed in a panelboard), manufacturer or Contractor shall furnish all equipment, brackets and appurtenances necessary in order to properly install suppressors to manufacturer's requirements.

The suppression system shall incorporate thermally protected metal oxide varistors (MOVs) as the core surge suppression component for the service entrance and all other distribution levels. The system shall not utilize silicon avalanche diodes, selenium cell, air gaps, etc. Maximum Continuous Operating Voltage (MCOV) – The MCOV shall be greater than 125% of the nominal system operating voltage.

Electrical Requirements – Power Distribution Equipment

1. Unit operating voltage and configuration – Refer to Drawings

2. SPD Types:

Type 1: Can be installed before service disconnect overcurrent device. (Old equivalent: Secondary surge arrester, lightning arrester.) Nominal Discharge Current Rating - 10kA or 20kA.

Type 2: Can only be installed after service disconnect overcurrent device. (Old equivalent: TVSS) Nominal Discharge Current Rating - 3kA, 5kA, 10kA or 20kA.

Type 3: Point of Utilization SPD. Installed a minimum 10m (30ft) of conductor between service disconnect overcurrent device and surge protective device. (Old equivalent: Plug-In surge strips, surge receptacles).

Type 4: Component SPD. Does not have full enclosure; intended solely for installation in another listed device. Must pass all tests relevant to installation location (Type 1 or Type 2). (Old equivalent: UR recognized component.)

Lighting and Distribution Panelboard Requirements. The following additional requirements shall apply when drawings indicate that the Surge Protective equipment is to be integral to the panelboard and mounted within the enclosure housing.

- a. The Surge Protection units shall be tested to demonstrate suitability for ANSI/IEEE C62.41 Category C1 environments.
- b. The Surge Protective Device shall not limit the use of Through-feed lugs, Sub-feed lugs and Sub-feed breaker features, where applicable.
- c. The Surge Protective Device shall be immediately installed on the load side of the main breaker.
- d. The panelboard shall be capable of re-energizing upon removal of the Surge Protective Device.
- e. A direct bus bar connection shall be used to mount the Surge Protective component to the panelboard bus bar to reduce the impedance of the shunt path.
- f. The Surge Protected panelboard shall be constructed using a direct bus bar connection.
- g. The surge Protective Device shall be included and mounted within the panelboard by the manufacturer of the panelboard.
- h. The complete panelboard, including the Surge Protection Device shall be UL-67 listed.

Devices shall be provided with integral thermal protection to disconnect the suppression components during an overheated MOV condition. In order to isolate the Surge Protective Devices under fault conditions, the assembly shall be U.L. rated for the same short circuit fault duty rating as the equipment to which it is connected. Provide supplemental fusing, if required, in order to meet this requirement. All

overcurrent protection components shall be tested in compliance with UL 1449 – Limited Current Test and AIC Ratings. Each unit shall include an EMI/RFI filter. Filter shall comply with UL-1283. Where practical, and to aid in keeping power lead/bus length short, Surge Protective Devices may be integrated into electrical distribution equipment enclosures.

Protection Modes: The SPD must protect all modes of the electrical system being utilized. The required protection modes are indicated by bullets in the following table:

LN = Line to Neutral
 LL = Line to Line
 LG = Line to Ground
 NG = Neutral to Ground

Wye System: LN-A Phase, LN-B Phase, LN-C Phase, LG-A Phase, LG-B Phase, LG-C Phase, NG

Delta System: LL-A Phase, LL-B Phase, LL-C Phase, LG-A Phase, LG-B Phase, LG-C Phase

Single Phase System: LN-A Phase, LN-B Phase, LG-A Phase, LG-B Phase, NG

High Leg Delta: LN-A Phase, LN-B Phase, LN-C Phase, LG-A Phase, LG-B Phase, LG-C Phase, NG

Voltage Protection Ratings (VPR) shall not exceed the following per UL-1449:

Modes	208Y/120	480Y/277
L-N; L-G; N-G	600 V	1000 V
L-L	900 V	1800 V

Construction Methods

1-3.1 General. The installation of the utility service, panelboards, disconnect, transformer, strut type framing and foundation shall be as detailed on the plans and in conformance with manufacturer's recommendations.

1-3.2 Grounding and Bonding.

The Contractor shall furnish and install all grounding and bonding as required per NEC and all Local Codes, whether or not specifically shown on the project drawings. Equipment ground conductors (green insulated) shall be used solely for grounding and bonding purposes and be kept entirely separate from grounded neutral conductors (white insulation), except where bonded at the Service Entrance equipment. All metallic raceways, boxes, enclosures, etc. shall include an insulated equipment ground conductor. Due to corrosion, metallic raceway and conduit connectors alone WILL NOT be considered as meeting this requirement. The Equipment Grounding Conductor shall positively bond all electrical components and utilization equipment to the facility ground system. All metallic boxes used for electrical equipment shall include listed grounding screws or lugs. No more than one grounding conductor shall be installed per lug location unless lug is listed for multiple conductors.

1-3.3 Service Entrance.

Pad-mounted transformer shall be installed on concrete pad per utility company specifications and details. Concrete pad shall be level. Surrounding earth shall be thoroughly tamped, graded, fertilized, and seeded. If erosion appears to be a problem, Contractor shall install rock to control erosion. Contractor shall furnish and install utility metering equipment as required by serving utility and shall coordinate the location of this metering with serving utility and owner's authorized representative. In order to minimize down-time to the existing facility, an existing service shall remain in service as long as possible until new service or modifications are in place and ready for switch-over. Any shutdown or disruption of the existing facility power distribution shall be coordinated with the owner and engineer. A minimum of 72 hour written notice of any such shutdown shall be furnished by contractor before commencing with any such work. Before

disconnection of any existing service entrance or power, new improvements shall be fully installed, checked out and ready for commission. Any existing utility equipment to be de-commissioned or removed shall be done only after new improvements have been thoroughly tested and accepted for permanent operation.

1-3.4 Supports and Foundation. Install products in conformance with manufacturer’s instructions and as detailed in drawings. Provide anchors, fasteners and supports in accordance with NECA Standard of Installation. Do not use spring steel clips or clamps except as noted. Do not fasten supports to pipes (except where detailed on drawings), ducts, mechanical equipment (except where detailed on drawings), or conduit. Install surface mounted cabinets, enclosures, and panelboards with a minimum of four anchors. Provide materials, sizes and types of anchors, fasteners, and supports necessary to carry loads of equipment and conduits. Consider weights of equipment and conduit when selecting products. Provide all necessary hardware, such as floor flanges, in order to install equipment as specified or as shown on the drawings. Include knee-braces and stiffeners as necessary to provide rigid support such that equipment does not bounce or sway. Use spring-lock washers under all nuts.

1-3.5 Panelboards. Install panelboards in accordance with manufacturer’s directions and in accordance with NEMA PB1.1. Install panelboards plumb. Provide filler plates for unused spaces in panelboards, if applicable. Provide typed circuit directory for each branch circuit panelboard. Revise directory to reflect circuiting changes as required. Provide legend plates for all panelboards to identify panelboard as well as voltage, phase and number of wires. Panelboard Surge Protective Device shall be installed.

1-3.6 Distribution Transformer. Transformer shall be suitable for floor mounting. Transformer core shall be constructed with high-grade, nonaging, grain-oriented silicon steel with high magnetic permeability, and low hysteresis and eddy current losses. Maximum magnetic flux densities shall be substantially below the saturation point. The transformer core volume shall allow efficient transformer operation at 10% above the nominal tap voltage. Transformer windings may be either copper or aluminum using continuous wound construction. Per Federal Requirements described in 10CFR Part 431 “Energy Efficiency Program for Certain Commercial and Industrial Equipment”, all Dry-Type transformers 15 kVA and larger shall comply with NEMA Standard TP-1. Terminals shall be provided for external cables rated 90°C applied at 75°C ampacity. Unless otherwise noted or specified for environmental reasons, enclosures shall be ventilated. Provide lifting brackets or lifting eyes.

Insulation System of transformer shall be as follows:

1. 2 KVA and below: 150° C insulation based upon 80° C rise.
2. 3.0 to 15 KVA: 185° C insulation based upon 115° C rise
3. 15 KVA and above: 220° C insulation based upon 150° C rise

Performance shall be obtained without exceeding the specified temperature rise in a 40° C maximum ambient. Units shall be designed for continuous operation, with normal life expectancy as defined in ANSI C57.96. Insulation materials shall be flame-retardant and shall not support combustion as defined in ASTM Standard Test Method D635.

The enclosure shall be made of heavy-gauge steel with NEMA 3R rating. Unit shall be equipped with a wiring compartment suitable for conduit entry and large enough to allow convenient wiring. The maximum temperature of the enclosure shall not exceed 90°C. The core of the transformer shall be grounded to the enclosure.

Transformer maximum audible sound levels shall not exceed the following per IEEE C57.12.01 and NEMA ST-20 for 600-Volt Class, self-cooled units:

0	to	9 kVA	40db
10	to	50 kVA	45db

51	to	150 kVA	50db
151	to	300 kVA	55db
301	to	500 kVA	60db
501	to	700 kVA	62db
701	to	1000 kVA	64db
1001	to	1500 kVA	65db

1-3.7 Receptacle Pedestals.

Unless otherwise specified on the drawings, use the following as a guide for mounting of device boxes. All receptacles shall be grounded with a ground conductor connected to their respective grounding terminal or screw. Ground device enclosure or box with a ground conductor connected to the respective grounding lug or screw. Unless otherwise specified, install duplex outlets with ground blade on the bottom if mounted vertically or to the right if mounted horizontally. Install GFCI receptacles in such that “Test” and “Reset” wording are oriented correctly. Each duplex outlet cover shall be furnished with a 3/8”-1/2” adhesive label strip identifying its respective source of supply (e.g. PP1-15 for Power Panelboard PP-1 circuit #15). All labels shall be affixed to the exterior (outside) of each respective cover plate. All duplex outlet labels shall be installed in the same general location on each cover plate throughout the project.

1-3.8 Surge Suppressor.

Control panel surge protection shall be installed per manufacturer’s instructions.

Method of Measurement

1-4.1 Grounding and Bonding.

All grounded metal cases and parts associated with electrical equipment shall be tested for continuity with ground system. Each Ground Field shall be tested for resistance to earth a “three-terminal” or “fall-of-potential” test as described in IEEE Standard #81. As an alternate, a specially designed clamp-on instrument such as AEMC Model 3710 (now superseded by Model 6416) or 3730 (now superseded by Model 6417) may be used if found acceptable to the engineer. Based upon measured field data, the Contractor shall calculate the ground field resistance and furnish record copies to the Engineer and Owner for record. In no case shall the ground field resistance exceed 25 ohms. If the resistance is found to be higher than 25 ohms, one additional rod shall be driven with a minimum separation equal to the length of the ground rod used and connected in parallel with the rod under test. Provide a copy of all testing reports to Engineer for record purposes.

1-4.2 Service Entrance.

Entire service entrance system shall be tested. Perform testing in accordance with serving utility’s recommendations.

1-4.3 Panelboards.

Panelboards and load centers shall be thoroughly tested after installation and connection to respective loads. Lighting panelboard phases shall be measured with all major items operating. Phase loads shall be within 20 percent of each other. Rearrange circuits if required maintaining proper phasing for multi-wire branch circuits. Test for shorts and high resistance grounds. Check for faulty operation of circuit breakers and correct as needed.

1-4.4 Distribution Transformer.

Check for damage and tight connections prior to energizing transformer. Adjust primary taps so that secondary voltage is within 2% of rated voltage.

1-4.5 Receptacle Pedestals/Outlet Posts.

Test all receptacles for proper operation, including GFCI operation where applicable.

Basis Of Payment

1.5.1 General.

Payment will be made at the contract unit price for each item and shall be full compensation for all conduit and wiring, core-drilling, materials, parts, installations, deliveries, labors, tools, and other incidentals necessary to complete this item.

Payment will be made under:

Item AW801968	Strut Framing and Pedestal – per lump sum
Item AW801969	Utility Service Installation – per lump sum
Item AW801980	75kVA Distribution Transformer, 480-208Y/120V, 3PH, 4W– per each
Item AW801981	Distribution Panel Board, 200A, 480/277V, 3PH, 4W, NEMA 3R, 30CKT per each
Item AW801985	Power Panel, 200A, 208Y/120V, 3PH, 4W, NEMA 3R – per each
Item AW801998	Non-Fusible Service Disconnect, 200A, 600V, 2-Pole, NEMA 3R – per each
Item AW801967	Receptacle Pedestals – per each

END OF ITEM SP-5

SP-8 – Valves & Actuators**PART 1: GENERAL****8-1.1 SUMMARY****A. Section Includes**

1. Installation of new valves with electric motor actuators.

8-1.2 PROOF OF BUY AMERICAN NOTICE: All tier contractors and subcontractors shall provide proof of Buy American compliance for all manufactured products.

All materials used for this work shall meet the requirements of Buy American in accordance with Title 49 U.S.C. § 50101. The product manufacturer shall submit a certification statement or waiver request for each proposed material. All waiver requests shall be submitted prior to issuance of the Notice to Proceed. No waiver will be allowed for steel. The AIP Buy American preference does NOT recognize US trade agreements such as NAFTA. The American Recovery and Reinvestment Act (ARRA) does not satisfy the AIP Buy American requirement.

8-1.3 SUBMITTALS

A. Manufacturer's certifications shall not relieve the Contractor of their responsibility to provide materials in accordance with these specifications and acceptable to the RPR. Materials supplied and/or installed that do not comply with these specifications shall be removed, when directed by the RPR and replaced with materials, which do comply with these specifications, at the sole cost of the Contractor.

B. All materials and equipment used shall be submitted to the RPR for approval prior to ordering the equipment. Submittals consisting of marked catalog sheets or shop drawings shall be provided. Clearly mark each copy to identify pertinent products or models applicable to this project. Indicate all optional equipment and delete non-pertinent data. Submittals for components of equipment and systems shall identify the equipment for which they apply on each submittal sheet. Markings shall be clearly made with arrows or circles. Highlighting is not acceptable. The Contractor shall be responsible for delays in the project accruing directly or indirectly from late submissions or resubmissions of submittals.

C. The data submitted shall be sufficient, in the opinion of the RPR, to determine compliance with the plans and specifications. The Contractor's submittals shall be submitted in electronic PDF format. The RPR reserves the right to reject any or all equipment, materials or procedures, which, in the RPR's opinion, does not meet the system design and the standards and codes, specified herein.

E. Product Data: Provide the following for each actuator:

1. Materials of construction
2. Dimensional drawings.
3. General arrangement drawing shall show shaft, diameter and key connection.
4. Electrical characteristics of position switches (where applicable).
5. For manual operation of electrically operated valves, provide force requirements for hand wheels, cranks, etc.

6. Full cycle operating time.
7. Maximum torque capability in accordance with AWWA C540 and AWWA C504 for butterfly valves.
8. Electrical wiring diagrams.
9. Motor insulation class.
10. Motor running Full Load Amps (FLA).
11. Details on electronic controls and wiring (4 to 20 ma analog; Profibus network interface, etc.).
12. One set of detailed installation/instructions for each actuator.

8-1.4 WARRANTY

- A. All equipment and materials furnished and installed under this section shall be guaranteed against defects in materials and workmanship for a period of at least twelve (12) months from the date of final acceptance by the Owner, not the installation date. The defective materials and/or equipment shall be repaired or replaced, at the Owner's discretion, with no additional cost to the Owner

PART 2: PRODUCTS

8-2.1 MANUFACTURER

- A. Information associated with the equipment from the manufacturer named below was used as the design basis as specified herein and shown on the drawings.
1. Rotork Controls, Inc.
 2. DeZURIK Valves, Inc.

8-2.2 ACTUATORS

- A. The actuators supplied under this section shall consist of the following basic components:
1. Motor phase and power supply shall be as shown on electrical drawings and specified and incorporate motor, integral reversing starter, local control facilities, and terminals for remote control and indication connections.
 2. A device to ensure that the motor runs with the correct rotation for the required direction of valve travel with either phase sequence of the three-phase power supply connected to the actuator.
 3. Ability to carry out the setting of the torque, turns, and configuration of the indication contacts without opening or removing any electrical compartment covers.
 4. Two-way communication must be possible to facilitate downloading actuator setup.
 5. Diagnostic information shall be available from both an integrally mounted display window and through non-intrusive means of reading and writing data to the actuator.
 6. Separately sealed terminal compartment to prevent moisture ingress. The primary fuses must be located in the STC for ease of replacement. Terminal identification must be clearly marked as an integral part of the terminal strip.
 7. Manual hand wheel with automatic re-set lever for emergency non-power operation. The maximum rim pull must not exceed 80 pounds.

8. Local indicator of valve position. Digital local position indication in 1% increments.
9. Non-Intrusive local electrical control push button/rotary switch for electrical control of valve position.
10. Padlock capable Local-remote control selector switch.
11. A drive sleeve and/or spline adapter board and keyed by the Actuator Manufacturer for four (4) 90-degree positions.

8-2.3 ACTUATOR GEARING

- A. The actuator gearing shall be totally enclosed in an oil or grease filled gearcase suitable for operation at any angle.
- B. All main drive gearing must be of metal construction. The gear box must be of ductile iron construction. Aluminum is not acceptable.
- C. The drive design should permit the gearcase to be opened for inspection or disassembled without releasing the stem thrust or taking the valve out of service.
- D. The actuator gear units shall be lubricated with heavy food grade oil or grease. The lubricant shall be suitable for ambient conditions of minus -40 to +160 degrees F.
- E. The actuator lubricant shall be suitable for installation in any position without operational detriment or loss of lubricant.

8-2.4 ACTUATOR SAFETY FACTORS

- A. Valve actuators shall be designed and supplied to provide the safety factors as required by the most current edition of AWWA C540 or AWWA C504 for the torque values established by the valve manufacturer.

8-2.5 ACTUATOR CYCLING

- A. The actuators shall be designed and supplied to provide an open-closed operating cycle time for the valve of 90 seconds or less.

8-2.6 MOTOR AND MOTOR OPERATIONS

- A. The electric motor shall have minimum Class F insulation, and shall be selected for operation at 104°F ambient temperature for at least 15 minutes or for 2 full valve stroke operations, whichever is greater, at 33% of the maximum dynamic torque required by AWWA C504 for Butterfly Valves and AWWA C540 for non-butterfly valves. The motors should be of an external frame type. The actuator should not require recalibration if the motor is removed or replaced.
- B. The motors shall be provided with an embedded thermistor or thermostat on one winding to prevent overheating in excess of insulation Class F limit, with an ambient temperature of 104°F.
- C. The actuators shall be provided with an electronic phase detector to automatically correct the phase orientation in the event of reverse motor operation.
- D. Three-phase actuators shall furnished with integral single-phase protection.
- E. The actuators shall be supplied with an integral reversing motor starter selected to permit 60 starts per hour. An integral control transformer shall be provided, sized to supply 120VAC for control of the motor starter, and all other 24VDC power requirements of the actuator.
- F. The motor shall be de-energized in the event of stall when attempting to unseat a jammed valve.

8-2.7 RIM PULL REQUIREMENTS

- A. For emergency manual operation of valves and gates, the gear box gearing shall be selected so that the rim pull requirements will meet AWWA C504 and C540 without exceeding an 80-pound maximum, with the following size and hand wheel diameter relationship listed below.
- B. Valve size and rim pull requirements are as follows:

VALVE SIZE	MAXIMUM HANDWHEEL DIAMETER
12" or Less	12"
14" and Larger	24"
Gate Vales	18"

8-2.8 ACTUATOR CONTROLS

- A. The actuators shall be provided with integral local-remote switch. This control shall permit operation from either a local push button/rotary switch installed on the actuator, or from remote locations. The remote locations (if used) shall be connected to the actuator by a twisted pair of conductors and shall be of a digital communication type or conventional hard wiring (multiple conduit wire cable). All local controls shall be non-intrusive in design.
- B. The actuators shall permit selection of either momentary contact for maintained operation, or non-maintained contact (jogging or inching) control operation. These two modes of operation shall be field selectable without removal of the actuator covers for local and remote operation.
- C. The actuators shall be provided with a handwheel for manual operation in the event of a power failure, or other emergency. The handwheel shall have a clutch that allows disengagement from the motor. Upon electrical rotation of the drive motor, the clutch will automatically disengage to keep the handwheel from rotating, preventing injury to operating personnel. Engagement of the manual drive or reengagement of the motor drive shall not cause damage to the actuator – even with the motor running,
- D. The manual drive and electric drive shall be independent of each other. A failure of either drive shall not result in the loss of both electric and manual operation.
- E. The actuators shall be stopped at the extreme open or close positions by either position contacts or torque limit contacts. The type used shall be compatible with the valve or gate type.
- F. The position contacts (switches) shall be positively controlled by a gear mechanism, and shall be pre-set by the valve or gate manufacturer when the actuator is mounted. These position contacts shall be field adjustable and non-intrusive. The position detection shall offer repeatability of 0.10% of valve shaft rotation, or better.
- G. The valve torque detection mechanism will be electro-mechanical. Torque indication based on motor current is not acceptable. The torque limit values shall be set when the actuator is mounted and shall be field adjustable. Mechanical torque springs shall be replaceable without the removal of the actuator.
- H. The actuators shall be provided with an interrupter-timer operation mode to reduce opening/closing speed. In this mode the motor ‘on’ and ‘off’ time periods shall be user-adjustable over any selectable portion of the stroke. The interrupter function shall be active for both local and remote control.

- I. Each actuator shall be programmed to automatically maintain a designated EMERGENCY POSITION in the event of a communication loss. This position is specified in the gate and electronically actuated valve schedules. The options for Emergency Positions shall be as follows:
 1. Full Open – The gate or valve is set to the full open position.
 2. Full Closed – The Gate or valve is set to the full closed position.
 3. Maintain Last Position – The gate or valve remains in the last designated position.
 4. Predefined Position – The gate or valve is set to a predefined position between open and closed.

8-2.9 REMOTE POSITION/ACTUATOR STATUS INDICATION

- A. Electric actuator must be installed with a manufacturer-provided remote control station. The remote control station shall be suitable for installation up to ~~1000~~ approximately 1,200 feet from the actuator. The remote control station must provide opening and closing control as well as actuator position feedback. *If the manufacturer's standard remote hand station is not capable of functioning over the required distance from the actuator, the remote hand station shall be equipped with an extended range option, or a standard pushbutton station consisting of open/close/stop pushbuttons and indicator lights shall be provided. Documentation indicating the suitability of the remote hand station for installations over the required distances shall be provided with the shop drawings.*
- B. In the event of a power loss or failure, the position contacts and local display shall continue to operate. However, the 24 volt control feedback will not continue to work, this will require an auxiliary power supply by others.
- B. The actuator must utilize an encoder directly geared to the drive mechanism for position. A position encoder dependent upon battery backup is not permissible.
- C. The position of the actuator and valve must be updated continuously, even upon loss of power.
 1. Four contacts shall be available to indicate any valve/gate position. An additional four contacts shall be available for position if required. The contacts can be selected as either normally open (NO) or normally closed (NC). The contacts shall be rated at 5A, 120V AC, 30V DC.
 2. As an alternative to providing position, any of the above contacts shall be available for:
 - a. Opening and Closing
 - b. Moving (Continuous or Pulsing)
 - c. Motor Running
 - d. Motor Stalled
 - e. Open or Close Interlock Active
 - f. ESD Active
 - g. Motor Tripped on Torque in Mid-Travel
 - h. Motor Tripped on Torque Going Open
 - i. Motor Tripped on Torque Going Closed
 - j. Pre-Set Torque Exceeded

- k. Thermostat Trip
 - l. Lost Main Power Phase
 - m. Customer 24V DC or 24 V AC Supply Lost
 - n. Battery Low (if battery included)
 - o. Actuator Alarm
 - p. Valve/Gate Alarm
 - q. Control Alarm
 - r. Local Stop
 - s. Local Selected
 - t. Remote Selected
 - u. Blinker
3. Provision shall be made for the addition of a non-contact-based transmitter to give a 4-20mA analog signal of travel for remote indication.
 4. Provision shall be made for the addition of a current torque transmitter (CTT) to provide a 4-20mA signal of valve torque demand for remote indication.

8-2.10 LOCAL POSITION INDICATION

- A. The local display shall have the valve/gate position, even when the power is lost. The display shall rotate in 90 degree increments for easy viewing regardless of actuator mounting position.
- B. The local display should be legible from a distance of six (6) feet.
- C. The local display shall include a digital position indicator from fully open to fully closed in 1% increments. Red, green, and yellow lights corresponding to Open, Closed, and Intermediate positions shall be included.

8-2.11 INTEGRAL STARTER AND TRANSFORMER

- A. The reversing starter, control transformer, and local controls shall be integral with the actuator, suitably housed to prevent breathing and condensation buildup.
 1. For non-modulating duty, the starter shall be electromechanical or solid-state suitable for 60 starts per hour rated for the motor size.
 2. For a modulating duty, provide a solid-state starter suitable for 1,200 starts per hour.
- B. The control transformer shall be fed from two of the incoming three phases. The primary and secondary windings shall have short circuit and overload protection. It shall provide power for the following functions:
 1. 110V AC for remote controls. (Alternate 24V DC output).
 2. Supply for all the internal electrical circuits.

8-2.12 INTEGRAL PUSH-BUTTONS AND SELECTOR

- A. The necessary wiring and terminals shall be provided in the actuator for the following controls:
 1. Connections for external remote controls shall be fed from either an internal or external supply. The power provided shall be either 24V DC or 120V AC.

2. The remote push button station shall have one of the following combinations:
 - a. Open, Close and Stop
 - b. Open and Close
 - c. Overriding Emergency, Shutdown to Close (or Open) Valve from a selectable “Make” or “Brake” Contact
 - d. Two-Wire Control, Energize to Close (or Open), De-Energize to Open (or Close)
 3. Each motor actuator shall include factory-installed Network Interface as noted in the contract documents.
 4. The internal circuits associated with the remote control and monitoring functions are to be designed to withstand simulated lightning impulses of up to 2.0kV.
- B. A remote push button station shall be provided for any actuator that is more than six feet above the standing elevation, or when indicated on the drawings. The push button controller shall be NEMA 4X with 30 mm operators, allowing indication and control for open and closed operation. Units shall also include a manual automatic switch and a stop push button.

8-2.13 MONITORING & DIAGNOSTICS FACILITIES

- A. Provide monitoring for the following:
1. Monitor (availability) relay, having one change-over contact, the relay energized from the control transformer when the Local/Off/Remote selector is in the "Remote" position and thermostat is not “tripped”. Signaling availability for remote (control room) operation.
 2. Where required, provide indication of thermostat trip and "Remote" selected as discreet signals.
 3. Display valve torque demand as a percent of rated actuator torque and position simultaneously, in order to facilitate valve trouble shooting and diagnostics.

8-2.14 WIRING AND TERMINALS

- A. Internal wiring shall be stranded cable insulated by tropical grade PVC at the appropriate size for the control and three-phase power. Each wire shall be clearly identified at each end.
- B. The terminals shall be embedded in a terminal block of high tracking resistance compound.
- C. The terminal compartment shall be separated from the inner electrical components of the actuator by means of a watertight seal.
- D. The terminal compartment of the actuator shall be provided with a minimum of three threaded cable entries. Cable terminations shall be fitted with a cable gland to prevent ingress of moisture.
- E. All wiring supplied as part of the actuator shall be contained within the main enclosure for physical and environmental protection. External conduit for connections between components is not acceptable.
- F. Control logic circuit boards and relay boards must be mounted on plastic mounts to comply with double insulated standards.
- G. A durable plan view of terminal wiring shall be attached to the inside of the terminal box cover indicating:

1. Serial Number
2. External Voltage Values
3. Wiring Diagram Number
4. Terminal Layout

H. All cable connections to equipment shall be rated for submersion.

8-2.15 ENCLOSURE

- A. Covers shall be ‘O’ ring sealed, watertight to NEMA 4 and 6 rated for an IP68 submersion rating of 21 feet for 72 hours. An inner watertight and dustproof ‘O’ ring seal between the terminal compartments and the internal electrical elements shall protect the motor and all other electrical elements from ingress of moisture and dust when the terminal cover is removed for cabling.
- B. An external power supply shall not be necessary during on site storage.
- C. Enclosures shall include, at a minimum, a thermostatically controlled space heater.

8-2.16 PHYSICAL LIMIT SWITCHES

- A. Provide limit switches on valves and gates as indicated on the drawings for remote position indication. The limit switches and associated attachments shall be factory installed and set by the valve or gate manufacturer, unless otherwise indicated. Limit switches shall be double-pole, double throw (DPDT) type, heavy duty silver plated, adjustable cam operated and rated at 5 amps at 120V AC.

8-2.17 BUTTERFLY VALVES

- A. Type: Lug type and designed for service in stormwater/glycol mixture, suitable for installing with an electric actuator, unless otherwise specified or shown on Drawings. Valves shall have position indication.
 1. Materials:
 - a. Body Ductile Iron, ASTM A536
 - b. Seat EPDM
 - c. Disc Ductile Iron, ASTM A536, Nickel Plated
 - d. Shaft Stainless Steel
 - e. O-Ring EPDM
 2. Connections: Threaded lugged compatible with class 125 ANSI B16.1 and class 150 ANSI B16.5 flanges.
 3. Provide exterior epoxy coating on valve.
 4. Provide a stem extension for the valve so that the top of the actuator is within 12” of the underside of the trench drain cover as shown on the drawings.
 5. Standards: Meets AWWA C504 for shaft diameter and body wall thickness.
 6. Installation: Unless necessary due to installation conditions and approved by the Engineer, the valves shall be installed with the higher pressure on the seat side.
 7. Manufacturers: Dezurik BOS-US. No substitutions will be considered.

8-2.18 VALVE AND ACTUATOR SCHEDULE

Location	Valve Type	Valve Size	Quantity	Operator Type	Power Supply	Actuator Type	Push-Button Station Required	Emergency Position	Area Classification
East Apron Trench Drain	Butterfly	8"	1	Electric	208V, 3 ph, 60 Hz	Open-Close	Yes	Maintain Last Position	Class 1 Division 2
West Apron Trench Drain	Butterfly	8"	1	Electric	208V, 3 ph, 60 Hz	Open-Close	Yes	Maintain Last Position	Class 1 Division 2

PART 3: EXECUTION

8-3.1 DELIVERY OF EQUIPMENT

- A. The valve actuators supplied under this section shall be delivered to the valve manufacturer for installation on the valve.
- B. The valve actuators supplied under this section shall be installed on its accompanying valve listed in the Valve and Actuator Schedule, by the valve manufacturer.

8-3.2 INSTALLATION

- A. Following installation of the valves and actuator assemblies by the Contractor, the valve and actuator manufacturers shall jointly activate, test, de-bug, make any and all adjustments and/or repairs necessary to the equipment furnished. The valve and actuator manufacturers shall demonstrate operation and provide operator training for the Owner.
- B. The valve and actuator assemblies will be exposed to the environment for up to 18 months before connected to its power supply.
 - 1. As a result, the actuator assembly will be designed to prevent damage to the internal components from these conditions.

8-3.3 FINISHES

- A. All exterior coatings shall be in accordance with the manufacturer's standard finish.
- B. The contractor will not apply any additional coatings other than touch up. The manufacturer will supply the contractor touch up paint.

8-3.4 MANUFACTURER'S SERVICES

- A. The valve and actuator manufacturers shall provide equipment startup by the manufacturer's technical representative. The manufacturer's representative shall inspect the complete installation and calibrate and adjust equipment as necessary and correct or supervise correction of defects or malfunctions.
- B. The Manufacturer's technical representative shall instruct the Owner's personnel in the proper operation and maintenance procedures for each valve and actuator.
- C. The contractor shall include in his bid services for the manufacturer's technical representative for equipment startup and training. This shall be at minimum one (1) trip for one (1) eight (8) hour day.

PART 4: METHOD OF MEASUREMENT

8-4.1 VALVES AND ACTUATORS. Valves and Actuators shall be measured by the unit installed and accepted by the RPR as compliant with the plans and specifications. Connections shall not be measured directly for payment but included in the cost of the items measured for payment. Remote position indicator shall not be measured separately for payment, but shall be included in the cost of the actuator.

PART 5: BASIS OF PAYMENT

3-6.1 PAYMENT. Payment for the furnishing and installation of valves and actuators, including remote position indicators, shall be made at contract unit price for the unit of measurement as specified above.

These prices shall be full compensation for furnishing all materials and for all preparation, Installation, and placement of the material and for all labor, equipment, tools, and incidentals necessary to complete these items as specified herein and as shown in the plans and details.

Payment will be made under:

Item AW801972 8" Valve & Actuator – per each

END OF SECTION SP-8

Item SP-9 BLV Badge Requirements

I. APPLICABILITY

- A. All requirements noted below are applicable to the selected bidder only.
- B. Badge applications are to be obtained and completed only by the selected bidder after award of the contract.

II. AIRPORT SECURITY

- A. Project Requirements for Secured Access and Access to the Airport Operations Area (AOA) or Movement Area (MA).
 - 1. **Some** work for this project will be within a secured area of the airport. The project **will** require Security Identification Display Area (SIDA) badge access.
 - 2. **Some** work for this project will require access to the Airport Operations Area (AOA) of the airport. The project **will** require that the Contractor drive **on the AOA**.
- B. Contractor shall ensure the worksite and Restricted Areas are maintained in a secure manner at all times to prevent entry into the Restricted Areas by unauthorized persons. Contractor shall have an adequate number of supervisors and/or employees obtain airport security badges from MidAmerica St. Louis Airport prior to commencing work on the project to provide worksite security and escort service during the term of the project.
- C. All work within a Restricted Area shall be subject to Airport security regulations. Any violation of Airport security rules is grounds for immediate termination of contract and relevant fines.

III. SECURITY BADGE REQUIREMENTS

- A. All persons working within the Security Identification Display Area (SIDA) of MidAmerica St. Louis Airport (BLV) **MUST** be under authorized escort or display an airport issued identification badge for unescorted access to the SIDA. Any person not under proper escort or in SIDA without an airport issued identification badge is subject to arrest and criminal and/or civil prosecution.
- B. Each badged person who has escort authority annotated on their Media ID may escort personnel in accordance with BLV rules and as long as all escorted persons are under the direct and immediate control of the person performing escort duties. The badge approval process and all fees are subject to change at any time. Violation of airport rules and regulations regarding airport issued identification and security procedures will result in revocation of the badge and possible criminal and/or civil penalties. No extension of time or other accommodation will be made to the construction contract due to loss of unescorted privileges for security violations.

IV. BADGE PROCESS

- A. Applications are available at <https://flymidamerica.com/business/id-badging/>
- B. Applicants must complete fingerprinting at the Public Safety Office by scheduling a new applicant/fingerprint appointment via the website.
- C. All paperwork must be completed, printed clearly, and legible. Any illegible paperwork will be returned and will delay issuance of the badge.
- D. Applicants must submit a complete packet to the Public Safety Office which includes:
 - 1. Badging Fees (see badge fees below) will be billed at the end of each month.
 - 2. Each company will designate an Authorized Signatory who will sign for new applicant badges for their company. The Authorized Signatory must complete the badging process before any new applicants they will sign for. Authorized Signatory Designation letter will be completed and signed at the time a badging. Authorized Signatory is responsible for all badges they sign for. Any badge that is not returned may face fines from airport, and lost badges may result in a fine of up to \$13,910 from TSA.

3. Application for airport access media/ID signed by applicant and Authorized Signatory (refer to your BLV contact to determine the answers to questions regarding the Drivers Permit, Escort Privileges, Keys, and Access Required).
4. Applicant must present two forms of ID as denoted on the I-9 form.

E. Training

1. Once the applicant's fingerprint results have been returned to the badging office, the badging office will contact the Authorized Signatory to schedule an online class. Once the online class(es) have been completed, the badging office will schedule in-person training and badge pickup with the Authorized Signatory.
2. Any applicant who will be designated as a driver on the Movement Area shall also attend and pass the MidAmerica St. Louis Airport Drivers Training Program and conduct airport familiarization and drive on the Movement Area. Only those individuals who receive this designation will be permitted to operate vehicles or equipment on MidAmerica St. Louis Airport (BLV).

V. BADGE FEES

A. General

1. Checks are payable to MidAmerica Airport.
2. Credit card payments are accepted which includes an added 3.4% convenience fee.
3. Your company is responsible for these fees.
4. All fees are subject to change at any time.
5. Fees may be waived and/or timeframes adjusted at the discretion of the Airport Director.

B. Initial Badging Fee - \$135.00

1. Covers the cost of fingerprinting and submission, security class/badging, and background checks through FBI and TSA (STA and CHRC)

C. SIDA Annual Renewal \$120.00

1. Required yearly by TSA - STA (Security Threat Assessment) and to rebadge an applicant

D. Broken / Damaged Fee - \$100.00

1. Cost to replace a broken or damaged badge.

E. Lost Badge Fee, Reissue Fee - \$200.00

1. Any badge not returned within 30 days of punchlist completion will be assessed the Lost Badge Fee and may also incur a TSA fee for not returning the SIDA badge.

F. Cyber Key Replacement - \$200.00

G. Lost Keys - \$100.00

H. Fees are subject to change during the term of this project.

VI. ESCORTING

- A. It is the Contractor's responsibility to provide escort services for all employees, sub-contractors, and vendors/suppliers requiring access to the construction site.
- B. The individual providing the escort will possess a valid Airport ID Badge and must stay within visual and verbal control of the escorted individual. The individual providing escort must be familiar with the Airport Rules and Regulations and the applicable Driver's Training Manual.
- C. The Contractor shall provide an escort vehicle, properly marked, with driver to escort delivery vehicles and construction equipment between the worksite and the identified entry gate to the work area. Escort driver shall have a valid airport identification badge with the appropriate privileges (Non-Movement Area or MA). Escort driver shall be trained by the badging office or designated official and conform to all rules and regulations of MidAmerica St. Louis Airport. Additional escort vehicles may be needed depending upon volume of vehicles.

- D. The Public Safety Office or designee will inspect all vehicles entering the AOA. No more than 3 vehicles may be escorted at one time. Vehicles must remain together and may not separate at any time from the escort caravan. Contractor shall ensure a communication system so that delivery drivers may contact the escort driver when waiting for escort at the airfield gate. Delivery vehicles shall not block traffic at the entrance gate(s) while waiting for escort. Vehicles may be directed off site if problems are created. All delivery vehicles must be escorted to and from the worksite. NO EXCEPTIONS. Any violation of these provisions or airport regulations may result in permanent revocation of security badges of those offenders.

VII. VEHICLE OPERATIONS

- A. If the applicant has requested a driver permit, the applicant's vehicle will be subject to a vehicle inspection by Public Safety. Public Safety will verify appropriate company marking, rotating beacon, and vehicle insurance. Vehicles operating on the AOA for greater than a month will be subject to a D.O.T. inspection by airport vehicle maintenance and an AOA permit will be issued. Only company vehicles will be permitted to drive unescorted on the AOA. No personal vehicles are authorized.
- B. Driving on the AOA
1. All Contractor's employees who will be designated as drivers for the Contractor shall also complete the MidAmerica St. Louis Airport Drivers Training Program. Only those individuals who receive this designation will be permitted to operate vehicles or equipment on MidAmerica St. Louis Airport (BLV).
 2. Contractor work crews must maintain radio contact with the Air Traffic Control Tower at all times when in the MA. MidAmerica St. Louis Airport will supply the Contractor with appropriate radio(s).
 3. The Contractor shall be responsible for keeping all dirt, mud, and debris off the paved surfaces of the AOA. If any dirt, mud, or debris from the Contractor's activities comes in contact with a paved surface in the AOA, the Contractor shall take immediate action to remove the items and thoroughly clean the surface to the satisfaction of the Engineer.
 4. Refer to the Safety Plan and Compliance Document (SPCD) and Construction Safety and Phasing Plan (CSPP), if included as part of the drawings, for additional requirements.
- C. Driving Requirements
1. There must be a true necessity for contractors to drive unescorted. The applicant will also be required to take and successfully pass Driver's Training online. The Contractor must agree to comply with the rules and regulations and maintain the minimum insurance requirements as established by MidAmerica St. Louis Airport.
 2. Vehicles accessing the airfield shall display a flashing or rotating amber beacon and will prominently display their company logo on the driver and passenger doors or be escorted by a properly marked and equipped vehicle.
 - a) Company logos are to be no less than 12" x 12", and readable from 250 feet.
 - b) Logos can be magnetic, printed or pasted on, but must be commercially made.
 3. A list of vehicles requiring access must be submitted to Airport Operations. This list must include make, model, and license plate number of each Contractor vehicle.
 4. Proof of insurance is required for each vehicle in accordance with BLV policies.
 5. Only vehicles which are company owned (not personally owned) will be allowed on the AOA.
 6. Only those vehicles that are essential for the job will be authorized to have access; vehicles for the sake of convenience will not be permitted. No personal vehicles will be parked within the SIDA.
 7. Vehicles must be confined to the construction work limits. A pre-approved access route to the work site will be coordinated with Airport Operations.

VIII. METHOD OF MEASUREMENT

- A. No direct measurement shall be made for cost of new badges, renewal of badges, time for training and testing and any other time, materials or costs associated with badging and security requirements at the airport.

IX. BASIS OF PAYMENT

- A. Payment will not be made for BLV Badging Requirements. Costs associated with BLV Badging Requirements shall be considered incidental to the project.

END OF SECTION

SP-11 REPAIR HAUL ROUTE #2

DESCRIPTION

11-1.1 This item shall consist of repair of Haul Route #2 throughout the project due to operations caused by vehicles and equipment by this project or any adjacent projects that are using this haul route. Construction of any other access roads and staging area installations and removals shall be considered incidental to the project or paid for as called out in the plans. Any necessary seeding, mulching and restoration to existing conditions shall be considered incidental to this pay item.

MATERIALS

11-2.0 PROOF OF BUY AMERICAN NOTICE: All tier contractors and subcontractors shall provide proof of Buy American compliance for all manufactured products.

All materials used for this work shall meet the requirements of Buy American per Title 49 USC § 50101. The product manufacturer shall submit a certification statement or waiver request for each proposed material. All waiver requests shall be submitted before the Notice to Proceed issuance. No waiver will be allowed for steel. The AIP Buy American preference does NOT recognize US trade agreements such as NAFTA. The American Recovery and Reinvestment Act (ARRA) does not satisfy the AIP Buy American requirement.

11-2.1 GENERAL. The contractor shall coordinate with the airport and the RPR before repairs begin. The material shall meet IDOT Standard Specifications for Road and Bridge Construction, January 1, 2022, Section 402. Aggregate Surface Course, Type A or match the material in place or an approved equal by the RPR.

CONSTRUCTION METHODS

11-3.1 GENERAL. The Contractor shall furnish all material and labor to repair Haul Route #2 and place it in fully operational working condition. All areas shall be graded to drain and shall be seeded and mulched according to items T-901 and T-908. All earthwork associated with this pay item shall be considered incidental to this pay item.

All work shall be subject to the inspection and approval of the RPR, the RPR's authorized representative and the airport.

METHOD OF MEASUREMENT

11-4.2 The repair of Haul Route #2 shall be measured per the unit complete, in place, and accepted by the RPR. Seeding, mulching and restoration to existing conditions shall be considered incidental to the pay item. Any earthwork or excavation or hauling for disposal or fill for the areas shall be considered incidental to the pay item. Any improvements necessary during repair shall be considered incidental to the pay item.

BASIS OF PAYMENT

11-5.1 This price shall fully compensate the Contractor for furnishing all materials and for all preparation, coordination, and installation of these materials; assembly, testing, training, and all labor, equipment, tools, and incidentals necessary to complete the item.

Payment will be made under:

Item AW801995

Repair Haul Route #2 – per TON

SP-12 - Glycol Control Panel**PART 1 GENERAL****1.01 WORK INCLUDES**

- A. The work included in this section is the supply and installation of a duplex pump control panel as detailed herein and as required to provide a complete and operational electrical and control system.
- B. Pump control panel is to be furnished by the pump manufacturer's representative in order to ensure single-source responsibility
- C. Electrical Contractor work under this item is limited to installing the control panel, including concrete foundation, unit strut rack, handhole and providing conduit, power and control wires, fiber optic cable and cable terminations.
- D. This work shall also include removal of existing pump controller, rack and foundation.

1.02 RELATED SECTIONS

- A. Specified Elsewhere:
 - 1. Section SP-13-16010 - General Electrical Requirements.
 - 2. Section SP-13-16111 - Conduit and Raceway.
 - 3. Section SP-13-16123 - Building Wire and Cable.
 - 4. Section SP-13-16170 - Grounding and Bonding.
 - 5. Section SP-13-16190 - Supporting Devices.
 - 6. Section SP-13-16195 - Electrical Identification.
 - 7. Section SP-13-16901 - Level Sensing and Measurement.
 - 8. Section SP-13-16950 - Testing Electrical Systems.

1.03 REFERENCE TO STANDARDS

- A. ANSI/NFPA 70 - National Electrical Code
- B. NECA - National Electrical Contractors Association.
- C. NEMA ICS 1 - General Standards for Industrial Control Systems.
- D. NEMA ICS 2 - Standards for Industrial Control Devices, Controllers and Assemblies.
- E. NEMA ICS 6 - Enclosures for Industrial Controls and Systems.
- F. U.L. 508 - Industrial Control Equipment
- G. U.L. 913 - Intrinsically Safe Apparatus and Associated Apparatus for Use in Class I, II, III, Division 1 Hazardous (Classified) Locations.
- H. Illinois EPA Title 35; Subtitle C; Chapter II; Part 370 - Illinois Recommended Standards for Sewage Works

- I. Recommended Standards for Wastewater Facilities; Great Lakes Upper Mississippi River - 10 State Standards
- J. ANSI/ISA - RP12.6 Recommended Practice - Installation of Intrinsically Safe Systems for Hazardous (Classified) Locations.
- K. NEMA 250 - Enclosures for Electrical Equipment (1000 Volts Maximum).
- L. ANSI/NEMA 250 - Enclosures for Electrical Equipment.

1.04 DELIVERY, STORAGE AND HANDLING

- A. Items shall be stored in original containers, protected from the weather and construction in a warm, dry, indoor area.

1.05 SUBMITTALS

- A. Submit product data under provisions of General Requirements.
- B. Submittals shall include cut sheets for the enclosure and for all components included in the control panel. Include schematics and wiring diagrams of the control system.
- C. Manufacturer's Instructions

Indicate application conditions and limitations of use stipulated by Product testing agency specified under Regulatory Requirements. Include instructions for storage, handling, protection, examination, preparation and installation of Product.

1.06 QUALIFICATIONS

- A. Pumping Control Panel shall be manufactured by a current U.L. 508A and U.L. 913 listed industrial control panel builder. If required by the Owner's representative, manufacturer shall submit a certification to a minimum experience of five (5) years in manufacture of equipment similar to that specified.
- B. Control panel does require an individualized U.L. label.

1.07 MAINTENANCE SERVICE (WARRANTY)

- A. Supplied equipment shall be warranted to be free from defects in material and workmanship for a period of one year from date of substantial completion established by the Owner.

1.08 EXTRA MATERIALS (SPARE PARTS)

- A. Provide one box five (5) minimum quantity of each type and size of fuse used in the control panel for spares.

1.09 OPERATION OF SYSTEM

A. Pumping Station Control

Operation of the pumps in the automatic mode shall be controlled by the level transducer with four float switches mounted in the wet well as backup. The level transducer and float switches shall be activated at the different water levels as shown on the drawings. Verify levels with Engineer at the time of installation. Wet well float switches are numbered 1 to 4 from lowest level to highest level.

When the water level is rising, the level transducer is activated and shall enable one pump to run in the automatic mode of operation. When the water level continues to rise and reaches the next level on the transducer the second pump shall be enabled to run in the automatic mode of operation. If the water continues to rise to the indicated high waterline the high-level alarm shall be activated. If the water level continues to rise the backup alarm shall be activated. When the pumps are operating, and the water level falls the pumps shall be shutoff at the indicated low water level.

When the water level is rising and float switch #1 (pumps off) is activated it shall enable the pumps to run in the automatic mode of operation. When float switch #2 (lead pump on) is activated it shall turn on the lead pump. If the water level falls while the pump is operating, the pump shall turn off when the water level falls below float switch #1. If the water level continues to rise and activates float switch #3 (lag pump on) the lag pump shall turn on and both pumps shall be operating simultaneously.

If the water level still continues to rise and reaches and activates float switch #4 (high water level alarm) the high water level alarm circuit shall be activated. The high level alarm shall be communicated to the existing Building Management System via 6-strand multi-mode fiber optic cable.

If the water level falls below float switch #1 both pumps shall shut off.

An alternating relay shall alternate operation of the two pumps each time the water level drops below float switch #1 and the pumps shut off.

PART 2 PRODUCTS

2.01 MANUFACTURERS

- A. Pumping Control Panel shall be manufactured by a current U.L. listed U.L. 508A and U.L. 913 industrial control panel manufacturer.

2.02 EQUIPMENT SPECIFICATION

- A. Pump Control Panel: The pump control panel enclosure shall be strut support mounted, NEMA 4X stainless steel or aluminum construction rated for outdoor use, and pad lockable. Enclosure shall have 3 point latching mechanism and handle for easy release. Enclosure shall not have clasps around the door to maintain a NEMA 4 watertight rating. Enclosure shall be manufactured by Hoffman, APX Enclosures, Hammond or Rittal, and

shall be adequately sized to accommodate equipment furnished. The enclosure shall also provide for "dead-front" construction using hinged inner doors (swing out panel) to mount all operator devices. Bond all panels and panel doors to ground. Hinges shall not be considered as an adequate grounding path. All hardware shall be corrosion resistant.

The proposed pump control panel shall be supplied by the pump manufacturer's representative in order to ensure single-source responsibility. The panel manufacturer shall be a current Underwriters laboratories listed UL 508A industrial control panel builder and shall show its follow-up service procedure file number on submittals. All devices within the panel shall be UL listed and/or recognized where applicable and shall be mounted and wired in accordance with the most current edition of UL 508 and the NEC. All conduit runs entering or leaving the pump station wet well shall have explosion proof conduit seals suitable for Class I, Division I, Group D environment. All conduits for intrinsically safe wiring shall enter the panel enclosure at the intrinsically safe section of the panel.

All conduit entries into the Pump Control Panel shall have watertight threaded hubs, U.L. listed for the respective NEMA 4X enclosure.

Include a label placed on the inside of the panel door with the name, address, phone number and emergency phone number of the service representative for the pumps and control panel.

The pump control panel enclosure shall be located as shown on the drawings. Where required, strut mounting equipment shall comply with Section 16190 - Supporting Devices. Include legend plates on inner and outer door labeled "CAUTION DISCONNECT SERVICE BREAKER BEFORE SERVICING". Lettering shall be black or silver on a red background.

The power feeding the pump control panel will be:

480	Volts
3	Phase
4	Wire

Control panel supplier shall include provisions for terminating incoming cables which shall consist of:

1	Number of conductors/Ø
#4	Phase Conductor AWG
#8	Ground Conductor AWG

Contractor shall furnish all equipment, labor, services, submittals, tools and work required to provide a complete and operational Pump Control Panel as shown on the drawings and specified herein.

The pump control panel shall include the following described equipment (installed complete and operational) as well as that shown on the drawings and specified herein.

1. Power Distribution Blocks: Each terminal block shall be provided with a clear plexiglass cover. Terminal block shall be Square D class 9080, Type LB, Gould-

Shawmut 68000-69000 Series, or Allen-Bradley Bulletin 1492 Power Blocks sized as required for the respective conductors.

All terminal blocks shall be rated 600 volt with amperage ratings in conformance with NEC Table 310-16 using 75°C wire for the respective lug wire range.

2. Three phase power monitor with adjustable nominal voltage setting: The device shall consist of a solid state voltage and phase angle sensing circuit driving two separate single pole relays, one normally open and the other normally closed. This device shall monitor phase loss, low voltage, phase reversal, and phase unbalance. This device shall drop-out pumps if all phases drop below 90% or if one phase drops below 80-83% of nominal voltage. This device shall have an adjustable 2 to 20 second drop out relay. Power monitor shall be Time Mark Corp. Model 2642, or Allen-Bradley Bulletin 8135 Line Voltage Monitor Relay. Furnish fuse block with three ½ Amp type KTK fuses. Adjust timing of drop out relay as required. Phase monitor shall be adjusted per the pump motor manufacturer's recommendation.
3. Secondary Surge Arrester: Secondary surge arrester shall be provided by the pump control panel manufacturer and be as specified under Section 16671. Install per manufacturer's directions, include mounting bracket.
4. Motor Circuit Protectors: Adjustable instantaneous trip magnetic-only circuit breakers shall be supplied for each pump motor, sized as required and in conformance with NEC. Adjustable instantaneous trip magnetic-only circuit breakers shall be Square D Class 680 MAG-GARD circuit breaker or Westinghouse Series C HMCP motor circuit protector, sized as required for each motor. Include Handle Padlock Attachment Square D Catalog Number HPAFK, or Westinghouse Key Interlock Kit, for each motor circuit protector breaker.
5. Motor Starters Solid-State Reduced-Voltage (SSRV): Each pump motor shall have a starter sized for pump motor to be supplied. Motor starters shall be combination motor circuit protector type, utilizing adjustable magnetic only trip motor circuit protectors, control power supply, and all control operators as detailed in schematics. SSRV frame size shall be based upon 1.15 Service Factor, and applied motor nameplate FLA and RPM, NOT manufacturer's standard HP tables. SSRV Units shall be similar to Cutler-Hammer Intelligent Technologies (IT) S811 series and include the following features as a minimum.
 1. "Severe-Duty" Rating
 2. Built-in 3-phase overload protection
 3. Adjustable ramp times (independent start and stop)
 4. Adjustable torque control
 5. Adjustable kick-start control
 6. Field Adjustable overload settings
 7. Run bypass contact to shunt around SSRV power module during "run" operation.

8. Kick-Start (Supply multiples of full load current for several seconds in order to provide additional starting torque.)
9. Ramp Start (Provide a constant increase in torque to the motor)
10. Current Limit Start (Limit the maximum current available to the motor during the startup phase.)
11. Multiple trip class settings (minimum NEMA Class 10, 20 and 30). Unless otherwise specified, set for NEMA Class 20
12. Integral Over-temperature Protection
13. Protection against, Jam, Stall, Phase Loss, Phase Reversal and Shorted Power Device Detection
14. Minimum Ambient Operating Temperature Range Capability -30°C to +50°C.
15. As a minimum, “dry contacts” shall be provided at the SSRV Starters for the following outputs for use by others:
 - Starter selector switch in “Auto”
 - “Pump Running”
 - “Starter Fail”
 Any “interposing relays” in the starters which may be required to provide these “dry contacts” shall be provided.
16. Enclosures shall be NEMA 1 for general purpose indoor applications, NEMA 4 for exterior applications or where otherwise noted on the plans, NEMA 4X for corrosive areas or where otherwise noted on the plans, and NEMA 7-9 for Class I Group B, C, & D, and Class I Groups E, F, & G areas.

Starters shall be Square D Altivar 48, Cutler-Hammer S801 Series, or Allen-Bradley SMC.

Starters shall be equipped with sufficient auxiliary contacts to accomplish the control indicated on the drawings and in the specifications plus one spare N.O. and one spare N.C. contact.

6. Pump Motor Ground Fault Protection: Per Illinois Recommended Standards for Sewage Works “Illinois Environmental Protection Agency (IEPA) Title 35; Subtitle C, Chapter II; Part 370.430c3” all submersible pumps and power cables shall additionally be furnished with motor ground fault protection. Equipment shall consist of either motor starters with integral ground fault protection or a separate ground fault sensing relay and matching C.T. sensor. Should a separate ground fault sensor arrangement be utilized, the “zero-sequence” Current Transformer opening shall be suitably sized to permit installing all three motor conductors thru the C.T. window for “zero-sequence” type sensing. Unless otherwise specified on drawings, sensing C.T. shall be 100:5 CT combined with Macromatic 3-phase Current Sensing Relay Model DIRT-110A. Utilize medium sensitivity A.C. input (Terminal E2) on current sensing relay. Ground fault control output contact shall be interlocked with motor control circuit and shall stop and lock-out motor operation should a ground fault condition occur. Visual indication of “tripped” condition shall be provided by means of pilot light on control panel and require manual reset in order to restart motor.

7. Intrinsicly Safe Barriers: Provide an intrinsicly safe isolation barrier for each float or any instrumentation device which extends into wet well. Barriers shall be Factory Mutual Listed or U.L. listed for Class I, Division 1, Group D environment. Barriers shall be so located in control panel as to physically isolate intrinsicly safe wiring from other power control cables with grounded metal barrier per Instrument Society of America ISA-RP12.6. All intrinsicly safe wiring shall be conductors with "intrinsicly safe blue colored" insulation only. Conduit entries into the pump control panel for intrinsicly safe systems shall be located at the intrinsicly safe section of the panel enclosure.

Intrinsicly safe barriers (switching amplifiers) shall be Pepperl & Fuchs Model WE77/EX2, or WE77/EX1, Gems Sensors Division Imo Industries Style SAFE-PAK or Diversified Electronics Model Number ISO-120-AFA.

Intrinsicly safe barriers for analog level transmitters, or any other instrumentation equipment which extends into the wet well shall be jointly listed for use with that manufacturer's equipment.

8. Alternating Relay: A SPDT alternating relay shall alternate each pump on each successive start command and be complete with a load selector toggle switch which will allow the alternation to be canceled and omit a disabled pump. Alternating relay shall be rated for 120VAC with 10 Amp contacts and shall be Timemark Corp. Model No. 261ST-120V, Diversified Electronics Model ARB-120-ABA, or Solid State Advanced Controls Part No. ARP41S. Include socket.
9. Unless specified otherwise on the drawings, control relays shall be heavy duty, "ice-cube" style, 11-pin (3PDT) socket mount, 120VAC operation with integral pilot light, contact rating of 10 Amps minimum, IDEC RR3PA-UL-AC120V, or equivalent. Provide all relays complete with matching plug-in socket IDEC #SR3P-05, or equivalent.
10. Unless specified otherwise on the drawings, time delay relays shall be heavy duty, socket mount. 120VAC operation with contact rating of 10 Amps minimum. Time Delay Relays shall as manufactured by IDEC as follows, or equivalent:
- a. On-Delay (Delay on Make) and Interval
RTE-P1AF20 & SR2P-05 Socket (DIN rail or Surface Mount)
 - b. Off-Delay (Delay on Break)
RTE-P2AF20 & SR3P-05 Socket (DIN rail or Surface Mount)
11. Unless otherwise indicated on project drawings, provide non-reset type, 120 VAC, run time meters with six digit LCD display for each pump. Meters shall display cumulative elapsed hours (5 digits) plus tenths of hours of operation. Meters shall be designed for flush door mounting unless otherwise noted on project drawings. The exposed face of all Run-Time Meters shall be NEMA 4X rated. Run Time (Elapsed Time) Meters shall be Redington Model 3311-1000/5003-005S, or equivalent.

Provide Legend plates labeled as follows:

"PUMP "X" HOURS" (where "X" designates Pump #)

12. Terminal blocks for control wiring shall be Heavy Duty 600 volt, tubular clamp style, with accessories as required, as manufactured by Buchanan, Allen-Bradley, or Cutler-Hammer, or Square D. Control panel interior wiring shall be MTW or THW sized as required per NEC minimum #14 AWG. All connections shall be checked for tightness and secured as required.
13. Mode Select: Method of operation shall be by a three position maintained "Hand-Off-Auto" selector switch provided for each pump. Selector switches shall be watertight/oiltight (NEMA 4/13) Allen Bradley 800T Series, Square D Class 9001, Type K, or Cutler-Hammer E22 or Cat. No. 10250 Series. Position commands are as follows:
 - a. Hand - In this position the applicable pump shall run without regard for the level sensing commands, except for the off float, and will rely on operator discipline to run and stop. Pump shall be controlled by start/stop pushbuttons in the hand mode of operation.
 - b. Off - In this position the applicable pump will not run under any circumstances.
 - c. Auto - In this position the applicable pump shall be controlled by normally open float switches. These switches will sense the appropriate level in the wet well and initiate start and stop commands to the pumps by switching the full voltage control power.
14. Pilot Lights: All pilot lights shall be "push-to-test" type with LED lamps, complete with one (1) normally open and one (1) normally closed contact block. Pilot lights shall be oil-tight and be "full size" (no less than 30 mm in diameter). Pilot lights shall be Allen/Bradley 800H Series, Square D Class 9001, Type SK Series, or equivalent. Pilot light indication shall include, but not be limited to, the following where "X" designates each pump #:
 - a. Pump #"X"; green-indicating pump #"X" is running.
 - b. Pump #"X" Overload Trip; red – indicating that pump #"X" has failed as a result of a starter overload trip.
 - c. Pump #"X" Thermal Trip; amber – indicating that pump #"X" has failed as a result of a thermal trip.
 - d. Pump #"X" Seal Leak; amber – indicating that pump #"X" has a seal leach failure, (where applicable)
 - e. Legend plates shall be provided for all pilot lights. Pilot lights shall be arranged on the panel such that the user shall be able to clearly distinguish between different operation and failure modes.
15. Legend Plates: Legend plates shall be required for all starters, circuit breakers, control panels, and disconnects. Legend plates shall be provided to identify the equipment controlled and the function of each pushbutton, indicating light, pilot light, selector switch and device. Legend plates shall be weatherproof and abrasion resistant phenolic material. Lettering shall be black on white background, unless

otherwise noted. All legend plats shall be attached with stainless-steel screws, double-face tape alone shall not be allowed.

16. Verify availability of thermal trip option and seal leak option with the manufacturer of existing pumps. Coordinate and furnish all additional pump protection components required by pump manufacturer for warranty purposes.
17. Pump Thermal Trip: (For motors equipped with motor winding thermostats). A thermal trip on the motor will cause immediate shutdown and activate the respective thermal trip condition pilot light and alarm light. Pump and motor thermal trip shall be wired to provide automatic reset and restarting of the pump motor. Pilot light and alarm light shall employ manual reset. Provide interposing relays as required.
18. Condensation Heater: Provide a condensation strip type heater sized as required for the pump control panel enclosure to minimize moisture that may accumulate inside the enclosure. Include integral thermostat and circulating fan for condensation heater. Circulating fan shall be 4" to 6" nominal diameter axial type fan with wire guards, 115 VAC, 60 Hz. Thermostat shall be line voltage thermostat, 120 VAC, 5 Amp minimum current rating, SPST, with adjustable control knob as manufactured by Honeywell, White-Rogers, Hammond, Hoffman, Rittal, or Chromalox.
19. Enclosure Light: Provide a LED light fixture for the pump panel control panel enclosure with door activated switch. Light fixture shall be Pentair/Hoffman Catalog Number LEDA1S35, or equivalent.
20. Convenience Duplex Receptacle: Provide a duplex receptacle with ground fault circuit interrupter as specified in Section 16141.
21. Fusing: Provide fuse protection as indicated on the drawings and specified herein for control circuitry. Fuses shall be rated 600VAC and shall be Bussman Class J or FNQ-R series fuses, Gould-Shawmut Class J or Class R fuses, or Littlefuse Class J or Class R fuses, sized as required and/or as indicated on the drawings with fuse blocks, with box lug terminals, sized as required. Include hardware for mounting. Provide one box (5 minimum quantity) of each type and size of fuse, upon completion of the job, for use as spares.
22. Circuit breakers for 120 VAC: Where circuit breakers are used instead of fusing for control circuits and other 120 VAC circuits they shall be thermal magnetic, molded case, 100 Amp frame, 10,000 Amps symmetrical, Interrupting current rating at 120 VAC, as manufactured by Square D, Challenger, Westinghouse, or Cutler-Hammer. Breakers shall have "on", "off" and "tripped" positions and shall be U.L. listed.

23. Pushbuttons: Pushbuttons shall be rated NEMA 4/13, watertight/oiltight, momentary contact normally open type or normally closed (where applicable) type with 10 amp minimum contact rating at 120VAC, Allen-Bradley 800H Series, Square D Class 9001, Type SK, or equivalent.
24. Alarm System: Provide an alarm strobe-light for the following alarm conditions.
- Motor starter overload trip.
 - Pump motor thermal trip.
 - Pump motor seal leak (where applicable).
 - High water level.
 - Loss of utility power/or voltage monitor alarm condition.

Alarm light shall be suitable for an outdoor industrial environment (NEMA 4X). Light shall consist of a strobe light mechanism with a flash rate of 65 to 96 times per minute. Impact resistant dome shall be red in color. Light shall operate on a voltage of 120VAC with an operating current of 10mA. Strobe lamp shall have a rated design life of 7,000 hours at approximately 175,000 candlepower. Light shall be 1/2" NPT Pipe Mountable. Alarm light shall be Federal Signal Model LP3P-120R (RED), or equal. Include all necessary gaskets and mounting hardware to install on NEMA 4X enclosure without sacrificing the enclosure listing. Silicone-rubber or similar sealants shall not be used to meet this requirement.

Include all necessary control relays, terminal blocks, wiring, etc. to provide the alarms functions noted above with a spare normally open contact output for each alarm function for future use.

Alarm Light shall be mounted to existing utility pole. Include all necessary additional brackets and mounting hardware to mount the alarm light. Refer to the plans for utility pole location.

25. Float switches: Furnish float switches of type and quantity detailed on the drawings. Float switches and mounting hardware shall be as specified in Section 16901 - Level Measurement.
26. Grounding Bar: Provide a copper grounding bar mounted and bonded inside the panel enclosure, adequately sized to accommodate all ground conductors to or from the pump control panel.
27. Duplex Alternating Controller (if applicable): Duplex controller shall alternate between the 2 pumps on each successive start command and be complete with a load selector toggle switch that will permit one pump to be omitted while sequencing the remaining pump. Duplex controller shall have U.L. listed intrinsically safe inputs suitable for Class I, Division 1, Group D hazardous location. Controller shall also provide inrush delay function to prevent multiple loads (pumps) from energizing simultaneously. Duplex alternating controller shall

be Diversified Electronics, Inc., Model ARM120AFE-P (SOSO; Sequence-On-Simultaneous-Off), or equal.

28. Alarm Dialer (if applicable): Unit shall comply with requirements in Section 16904.
29. Circuit Breakers: Circuit breakers shall be 600 VAC rated, 3 pole, Amps as shown on the plans thermal-magnetic circuit breaker. Circuit Breaker shall have minimum interrupting rating of 25 kA at system operating voltage. Circuit breakers shall be mounted inside the panel of the enclosure. When in the “off” position it shall disconnect all power to the equipment connected.
30. Current Monitor Relays (if applicable): Provide current monitor relays to monitor current in the motor leads and control run time meters based on operation of submersible pump motors (on or off). Current monitor relays shall be Diversified Electronics Model Number CMG-0100-20, or equal. Coordinate part number with specific pump FLA.
31. Control Power Transformer: 480 VAC to 120 VAC machine tool transformer sized as required, Square D Class 9070 Type K, or equal. Provide primary and secondary fusing using Bussman FNQ-R Series fuses, or equal, sized as required with Bussman Class CC fuse blocks with box lug terminals, or equal, sized as required. Ground the secondary side (X2) leg of the control transformer.
32. Communication: Provide communication module with fiber optic for alarm notifications and interface with existing Building Management System at the Airport. Install fiber optic patch panel to terminate fiber optic cable inside the pump controller enclosure. Coordinate fiber optic termination inside the terminal building with Airport IT department.

PART 3 EXECUTION

3.01 INSTALLATION

A. Pump Control Panel

1. Control panel shall be installed per manufacturer's recommendations as detailed on the drawings and as specified herein.
2. All conduit entries into the panel enclosure shall have watertight threaded hubs, Meyers or equivalent in order to maintain the NEMA 4X rating of the enclosure.
3. Seal all underground conduit openings that terminate within control panel enclosure as specified in Section 16111-2.02C.

4. Conduits with intrinsically safe wiring, including float switch cables, shall terminate in the control panel at the intrinsically safe wiring section. Non-intrinsically wiring including, but not limited to, power feeder conductors from the service entrance circuit breaker, branch circuit conductors, and pump motor cables shall not enter the control panel at the intrinsically safe wiring section and shall maintain a minimum separation distance inside the control panel from the intrinsically safe conductors as required by NEC 504 and ANSI/ISA RP12.6.
5. Install explosion proof conduit seals as detailed on the drawings and in conformance with Manufacturer's requirements. Contact the respective conduit seal off manufacturer if assistance is required for direction of installing the packing fiber to form a dam and pouring the sealing compound.
6. Remove existing concrete pad and unitstrut rack. Install new concrete pad and unitstrut rack as shown on the plans. Connect existing power and communication conduits. Existing power feed from the terminal building shall be reconnected to the new pump controller.

3.02 TESTING

A. Pump Control Panel

Supplier shall provide services of the pump control panel manufacturer's representative for the purpose of inspection, check-out, testing, start-up, instruction of user personnel, and any other required services to provide a complete and operational system. All tests shall be conducted in the presence of the Engineer. Contractor shall provide water as/if required to test pumps under load. Contractor shall furnish 3 copies of test results to Engineer. Supplier shall also furnish 3 copies of Operation and Maintenance Manuals, for operator personnel use, to the Engineer.

Start-up procedure and tests shall include, but not be limited to, the following as well as other tests and requirements specified herein.

- a. Conduct megger test on each motor.
- b. Check float switches and corresponding circuitry for proper operation.
- c. Inspect control panel for correct terminal connections and tightness, correct and tighten as required.
- d. Check oil in motors (if applicable).
- e. Check for correct rotation of pump motors, correct as required.
- f. Check for pump installation and operation.
- g. Measure voltage at no load (motor off) and at motor running under load.
- h. Measure current in each phase with motor running under load.
- i. Verify a label is provided on the pump control panel with the name, address, phone number, and emergency phone number of the service representative.
- j. Verify proper operation of all pilot lights and alarm lights.
- k. Test receptacles for proper operation.
- l. Instruct user personnel about the operation of the control panel and components; indicating items for routine maintenance check, operation modes, failure modes, alarm conditions, etc.
- m. Conduct any additional tests as required by the manufacturer.
- n. Verify tests and requirements are met as specified in Section 16010 - General Electrical Requirements, and Section 16950 – Testing Electrical Systems.

PART 4 BASIS OF PAYMENT

4.01 GENERAL

Payment will be made as a lump sum for all work associated with this item. payment shall be full compensation for all conduit and wiring, core-drilling, materials, parts, installations, deliveries, labors, tools, and other incidentals necessary to complete this item.

Payment will be made under:

Item AX801461 Glycol Lift Station Control Panel – per lump sum

END OF ITEM SP-12

SP-13 General Electrical Installation Requirements

PART 1 GENERAL

1.01 WORK INCLUDES

- A. Work included in this section is general in nature and applicable to electrical system work. Contractor is also directed to other sections of Division 16 - Electrical for additional related specifications for items described in this section.
- B. Work included in this section shall apply to installation and testing of all materials and equipment necessary to completely install electrical system as shown on drawings and as described herein in these specifications, or as may be necessary for a complete and operational electrical system.
- C. Unless otherwise noted, all electrical equipment shown on project drawings shall be furnished under Division 16.
- D. Drawings pertaining to this installation indicate general location of conduits, wiring, distribution and motor control centers, lighting and outlets, and other details necessary for installation of system.
- E. Electrical installation as shown on drawings and as specified herein is based upon best available information, with regard to characteristics of mechanical equipment specified. In the event changes are necessary in order to accommodate mechanical equipment furnished, necessary revisions will be made with approval of Owner's representative.
- F. Any minor changes in location of equipment, to include conduits, outlets, etc., from those shown on drawings, shall be made without extra charge if so directed by Owner's representative. These changes shall be any changes in location that, had new location been the bid-upon location, would not have resulted in an increase in contract construction cost over that actually bid.
- G. All electrical equipment shall be installed in conformance with applicable sections of NFPA 70 - National Electrical Code, respective equipment manufacturer's directions, as detailed on drawings and as specified herein. Any installations which void U.L. listing (or other third party listing) and/or manufacturer's warranty of a device or equipment shall NOT be permitted.
- H. RELATED CONTRACT WORK DESCRIBED ELSEWHERE IN THESE SPECIFICATIONS:

Electrical Contractor shall note that it is **not** the intent of these Division 16 specifications herein to be all-inclusive of electrically related work to be performed as part of this contract.

Contractor shall also comply with electrical requirements in these sections of the specifications, including, but not limited to, wiring of motors, control panels furnished by others, HVAC equipment and all other electrically powered equipment furnished by others under this project.

1.02 LAWS AND ORDINANCES

MidAmerica Airport
Terminal Apron

SP-13-1 General Electrical Installation Requirements

- A. In installation of this work, Contractor shall comply in every respect with requirements of National Electrical Code (NEC), National Board of Fire Underwriters, and any state and local requirements, laws and ordinances as may be applicable.
- B. If, in opinion of the Contractor, there is anything in drawings or specifications that will not strictly comply with above laws, ordinances and rules, the matter shall be referred to the attention of the Owner's representative for a decision before proceeding with that part of the work. No changes on drawings or in specifications shall be made without the full consent of Owner's representative.
- C. Contractor shall obtain and pay for all licenses, permits and inspections required by above laws, ordinances and rules for entire electric wiring job called for in these specifications and accompanying drawings.

1.03 DRAWINGS

- A. Drawings for electrical work will be a part of electrical drawings to which will be added, during the period of construction, any other detail drawings as may be necessary in opinion of Owner's representative, to show proper installation of various appliances or equipment with relation to project.
- B. Drawings and specifications are intended to be descriptive only, and any error or omissions of detail in either **shall not** relieve Contractor from obligations thereunder to install in correct detail any and all materials necessary for complete and operating electrical systems to extent shown on drawings and described in this specification.
- C. Contractor shall, during progress of job, record any and all changes or deviations from original drawings, and, at completion of project, shall deliver to Owner's representative a **single** marked-up set of "as-built" drawings.

1.04 SHOP AND ERECTION DRAWINGS

- A. This Contractor shall prepare shop drawings for all parts of his work. Before commencing any work or providing any material, Contractor shall submit for approval of Owner's representative all drawings relating to construction, arrangement or disposition of equipment entering into contract, and show complete equipment with manufacturer's specifications of same.
- B. Shop drawings of all distribution and motor control centers, panels, power and lighting systems, fixtures, wire, cables, devices, etc. shall be submitted for approval, as well as complete details of all systems not shown in detail on drawings.
- C. SHOP DRAWINGS SHALL BE FULLY DESCRIPTIVE OF ALL MATERIALS AND EQUIPMENT TO BE INCORPORATED INTO THIS PROJECT. CONTRACTOR SHALL CAREFULLY CHECK ALL SUBMITTED SHOP DRAWINGS, MAKING SURE THEY ARE COMPLETE IN ALL DETAILS AND COVER SPECIFIC ITEMS AS HEREINAFTER SPECIFIED.
- D. Shop drawings shall be submitted in sufficient quantity as required by the General Conditions. Three (3) copies will be retained by the Engineer for his use and records.
- E. No material or equipment shall be allowed at the site until shop drawings approved by the Engineer are received by the Resident Engineer at the site.

- F. The following information shall be clearly marked on each shop drawing, catalog cut, pamphlet, specifications sheet, etc. submitted:

PROJECT TITLE:

BRANCH OF WORK: ELECTRICAL

NAME OF BUILDING OR LOCATION:

PAGE OF DRAWINGS OR SPECS WITH WHICH EQUIPMENT COMPLIES:

DATE:

SUBMITTED BY:

PART 2 PRODUCTS

- 2.01 PRODUCTS SHALL BE AS SPECIFIED IN OTHER SECTION AND AS DETAILED ON THE DRAWINGS.

PART 3 EXECUTION

3.01 EQUIPMENT STORAGE

- A. Except as indicated below, **all** electrical equipment considered to be a part of this contract shall be stored before installation in a warm, dry, **indoor area** so as to protect the equipment from physical damage, freezing, dirt and any other harmful effects.
- B. The following electrical equipment shall be permitted to be stored outdoors on pallets or without direct contact with the earth, under tarpaulins or plastic covers:
1. Conduit. Does not include boxed fittings, etc., which shall be stored indoors.
 2. Cable Tray. Does not include boxed hardware, which shall be stored indoors.
 3. Ground Rods.
 4. Wire and Cable.
 5. Rebar.
 6. Strut-type framing members. Does not include boxed hardware, which shall be stored indoors.
 7. Exterior pad mount transformers.
 8. Exterior Pad-Mounted Med. Voltage Switchgear.
 9. Other electrical equipment not listed herein, with written approval of the Owner's Authorized Representative.
- C. The following electrical equipment shall be permitted to be stored exposed outdoors on pallets or without direct contact with the earth:
1. Light Poles. Does not include light fixtures or boxed hardware, which shall be stored indoors.
 2. Other electrical equipment not listed herein, with written approval of the Owner's Authorized Representative.
- D. The installation of electrical equipment shall not begin until the structure, if required, within which the equipment is to be permanently housed, is complete enough to provide

protection from weather and vandalism (i.e. roof, windows and temporary padlockable or permanent doors installed).

- E. The Contractor will be responsible for ensuring conformance with these procedures.

3.02 EQUIPMENT MOUNTING

- A. All equipment and materials shall be installed and completed in a first-class workmanlike manner. The right is reserved to direct the removal and replacement of any item, which in the opinion of the Owner's Representative and/or Architect/Engineer does not present an orderly and reasonably neat or workmanlike appearance, provided such items can be properly installed in an orderly way by usual methods in such work.
- B. The approximate location of all equipment and devices is shown on the Drawings. The Owner's Representative and/or Architect/Engineer reserves the right to change the location of all equipment or devices 6 ft in any direction at no additional cost provided such changes are requested before final installation.
- C. Install all equipment with ample space allowed for removal and repair. Provide ready accessibility to removable parts of equipment and to all wiring without moving equipment which is installed or which is already in place. Provide access panels for all devices installed above non-accessible ceilings and/or within walls or partitions.
- D. Install electrical equipment with due consideration to ventilating ducts, HVAC equipment, mechanical piping, etc., adjusting locations as necessary.
- E. Electrical equipment shall be installed to maintain minimum clearances per Article 110 of NEC and ANSI C2 (National Electrical Safety Code.)
- F. Electrical Contractor shall be responsible for furnishing and setting all anchor bolts required to install Electrical Contractor's equipment.
- G. Where concrete mounting pads are required for electrical equipment mounting, Electrical Contractor shall furnish all concrete and form work necessary to complete the installation.
- H. Where electrical equipment is located on damp or wet walls or locations as directed, it shall be "stand-off" mounted a minimum of ½" from wall in a manner so that rear of equipment is freely exposed to surrounding air. Method of mounting shall be approved by Owner's representative before equipment is mounted.
- I. Unless otherwise noted, top of safety-switches, control panels, and similar equipment shall be 5'-0" above finish floor or finish grade.
- J. Enclosures for panelboards, switches or overcurrent devices shall not be used as junction boxes, auxiliary gutters or raceways for conductors feeding through or tapping-off to other switches or overcurrent devices, unless adequate space for this purpose is provided and the equipment is listed for this use.
- K. In order to maintain NEC ratings and classifications of cables, do not combine conduit contents or modify conduit materials of construction unless specifically directed or shown otherwise on project documents.

- L. Per NEC 300.11(A)(2), when independent electrical equipment support wires are installed within dropped-ceiling areas, they shall be distinguished by color, tagging, or other permanent effective means.

3.03 COORDINATION

- A. Provide day-to-day coordination with the work of other contractors engaged in this project. Execute the work in a manner not to interfere with other Contractors, and vice-versa.
- B. Coordinate with other contractors regarding the location and size of pipes, raceways, ducts, openings, devices, so that there may be no interferences between installation or of the progress of any contractor.
- C. Coordinate installation of equipment and wiring with the established construction schedule.
- D. Provide temporary platforms and handrails as required, to allow installation of electrical components and raceway systems.

3.04 PROTECTION OF WORK

- A. Protect work from injury by keeping all conduit and boxes capped and plugged or otherwise protected. This includes damage by freezing and/or stoppage from building materials, sand, dirt, or concrete.
- B. Protect all equipment and fixtures from damages during the project, provide all tarpaulins, drop cloths, barricades, temporary heaters or auxiliary equipment.
- C. All materials or equipment damaged during construction shall be repaired or replaced with new items to the satisfaction of the Architect/Engineer.

END OF SECTION 16010

SECTION 16901- LEVEL SENSING EQUIPMENT**PART 1 GENERAL****3.05 WORK INCLUDES**

- A. The work on this section includes the supply and installation of level transmitters, float switches and all related mounting hardware and equipment as required to furnish a complete and operational electrical system.

3.06 REFERENCE TO STANDARDS

- A. U.L. Listed

3.07 DELIVERY, STORAGE AND HANDLING

- A. Level measurement equipment shall be stored indoors from time of delivery to jobsite, protected from weather and construction.

3.08 SUBMITTALS

- A. Submittal shall include electrical ratings, layout, wiring diagrams, U.L. listing, etc.

3.09 QUALIFICATIONS (RESERVED)**3.10 QUALITY ASSURANCE**

- A. The level measurement equipment shall be manufactured and supplied by a company regularly engaged in the business of furnishing level measurement equipment. If required by Owner, manufacturer shall submit a certification to a minimum experience of ten years in manufacture of level measurement equipment.

3.11 REGULATORY REQUIREMENTS (RESERVED)**3.12 COORDINATION (RESERVED)****3.13 MAINTENANCE SERVICE (WARRANTY)**

- A. All equipment shall be warranted to be free from defects in material and workmanship for a period of one year from date of substantial completion established by the Owner.

3.14 EXTRA MATERIALS (SPARE PARTS) (RESERVED)**PART 2 PRODUCTS****4.01 SUBMERSIBLE LEVEL TRANSMITTERS**

- A. Submersible level transmitters shall be provided as follows:

Location Name	Calibrated Span (USGS)	Transducer Span (psi)	Signal Output
Lift Station Wet Well	420.85-427.45	0 - 5 psi	4-20 ma DC

- B. The Transducer shall be of the solid-state head-pressure sensing type, suitable for continuous submergence and operation and shall be installed in accordance with manufacturer's instructions.
- C. The transducer shall be installed in a suitably sized wall-mounted PVC standpipe stilling well with diaphragm face of the sensor 6 inches above the floor of the wet well. Provide a stainless-steel hanging chain and stainless-steel latching ring at top of wet well in order to permit field-removal and adjustment.
- D. The transducer housing shall be fabricated of from stainless steel.
- E. A hydraulic fill liquid shall be factory installed behind the diaphragm in order to transmit the sensed pressure to the transducer element.
- F. Transducer electronics shall provide a 4-20 mADC output signal directly proportional to the sensed pressure.
- G. The internal pressure of the lower transducer assembly shall be relieved to atmospheric pressure through a heavy-duty jacketed hose/cable assembly and a slack bellows mounted in a upper-assembly enclosure. The sealed breather system shall compensate for variations in barometric pressure and expansion and contraction of air due to temperature changes and altitude as well as prevent fouling from moisture and other corrosive elements.
- H. The transducer assembly shall be installed where noted on the drawings and placed in successful operation. It shall be provided with input power and output signal transient protection, associated control elements as specified herein and in accordance with manufacturer's instructions.
- I. All components in contact with the wet well environment shall be third party listed for use in a Class 1, Division 1, Group D environment. Provide compatible isolating-type (active) intrinsically-safe barrier if required for hazardous location application.
- J. The Submersible Level Transmitter shall be "Birdcage" Model BC-1000 as manufactured by Blue Ribbon Industrial Components, Winter Park, Florida, U.S. Filter (Consolidated Electric Company) Bulletin A1000, Model 157GSCI, or KPSI Model 750 as manufactured by Measurement Specialties, Hampton VA or equivalent.

4.02 ULTRASONIC LEVEL TRANSMITTER

- A. Level indicator / transmitters shall utilize non-contact ultrasonic technology.
- B. Unit transducer shall be temperature compensated.
- C. Transmitter primary power is to be 120 VAC, 60 Hz, with isolated process signal output of 4-20 ma proportional to measured level into 750 ohm load.
- D. Separation between Transducer and electronics shall be up to 1000 feet.

- E. Transmitter electronics package shall be furnished in non-metallic NEMA 4X IP65) wall-mount enclosure suitable for outdoor use.
- F. Transmitter electronics shall include algorithms for open-channel flow measurement and volume conversion.
- G. Transmitter shall have no less than three (3) normally-open (N.O.) form “A” alarm/pump control relays with minimum rating of 5 Amps at 250 VAC. Relay operation shall be field programmable/re-programmable.
- H. Display shall be alphanumeric back-lit LCD.
- I. On units with a removable programming panel, furnish a minimum of one hand-held programmer for each project.
- J. Include a minimum of two (2) bound paper instruction manuals.
- K. Operating temperature for electronics shall be no less than -20° to 50°C.
- L. Liquid level resolution shall be no less than 0.25% of program range or 0.24”, whichever is greater. Calibrated range shall be from 1 ft to 50 feet with resolution of 0.1% of program range or 0.08” whichever is greater.
- M. Transmitter shall include a volume conversion algorithm for conversion of horizontal-cylindrical tanks.
- N. All transducer components located within a classified location shall be third party listed for use in a Class 1, Division 1, Group D environment.
- O. Wet Well Ultrasonic Level Transmitter shall be one of the following:
 - 1. Siemens/Milltronics HydroRanger 200 Model #7ML5034/7ML1034 series
 - 2. Pulsar, Inc; Shalimar, Florida; Ultra-3
- B. Compatible Level Transducers for Wet Well Ultrasonic Level Transmitters shall be ambient temperature compensated and shall be Milltronics XPS-10F (applications 1-33 feet) or XPS-15F (applications 1-50 feet), or equivalent. Where noted on project drawings, furnish transducer with 2” MNPT thread for installation into a 2” FNPT field adapter, Milltronics ST-H, or equivalent.
- C. The contractor shall provide factory trained recorder manufacturer’s representative for the purpose of field start-up, calibration and commissioning of the equipment. In addition, the factory trained representative shall provide minimum four (4) additional hours instruction for the owner on equipment set-up and maintenance procedures.

4.03 BUBBLER LEVEL MEASUREMENT SYSTEM

- A. Bubbler level measurement system shall dynamically measure the liquid level in a wet well and shall output a proportional 4-20 mADC signal representing this level.

- B. Two identical bubbler level measurement systems shall be provided. Each shall include the following equipment, features and options:
 1. Range: 0 - 2-1/2" to 0 - 400 ‘ H₂O, or equivalent, full scale.
 2. Output: 4-20 mdc, 600 ohm resistance.
 3. Accuracy: 0.5% of range.
 4. Ambient Conditions: -30° F to +170° F.
 5. Thermal Sensitivity: 0.01% per □F.
 6. Visual Flow Indicator (Rotameter).
 7. Built in air compressor.
 8. NEMA 4X fiberglass enclosure, 16"x18", with window.
 9. 120V power supply.
 10. Loss of Air Alarm.
 11. Clogged Dip Tube Alarm.
 12. Auto-Blowdown.
 13. Box Heater.
 14. Audio Alarm (use with setpoints for low and high level alarms).
- C. The bubbler level measurement system shall be Series 7600, as manufactured by Computer Instruments Corporation, or equivalent.

4.04 FLOATS (MERCURY FREE)

- A. Float shall be capable of tripping internal switch within two inches of specified elevation. Float housings shall be stainless steel “ball” approximately 5 inches in diameter.
- B. Floats shall be one of the following:
 1. U.S. Filter (Consolidated Electric Company); Model 9G-EF
 2. Anchor Scientific; Long Lake, Minnesota Roto-Float-SST/NM Type P
 3. Contegra; St. Paul, Minnesota Model FS-90

Unless specified or indicated otherwise on the drawings, all floats shall be normally open, with contact closing on rising water level.

- C. Unless otherwise noted on project drawings, a stainless steel clamp tube shall be furnished with an adapting fitting and two yokes for mounting to a vertically supported one inch Stainless Steel or Schedule 80 PVC pipe. One inch pipe shall be securely fastened to structure or wall at its ends with stainless steel pipe mounting brackets as detailed on drawings.
- D. Where floats are noted to be installed in a Class 1, Division 1, Group D environment wet-well, each float shall additionally be furnished with an intrinsically-safe barrier to provide the necessary interface between the classified and non-classified environments. Intrinsically safe barrier shall be F.M. or other third-party listed device.

FLOAT SCHEDULE

Float Location	No. of Floats	Cable Length (ft) (1)	Float Type (2)	Trip Elevation
----------------	---------------	-----------------------	----------------	----------------

Notes:

1. Lengths shown are FOR INFORMATION ONLY. Contractor shall field measure all float cable lengths required prior to ordering floats. A minimum of 5 feet of slack float cable shall be included in length to allow for adjustments of float actuation level.
2. A - N.O. contacts (contacts open on falling level).
 B - N.C. contacts (contacts close on falling).

4.05 FLOATS (USED FOR STRUCTURE “FLOOD PROTECTION)

- A. A. Gems Model #LS-270, or equivalent
 Unless otherwise noted on the drawings, install floats ½” above finish floor. Furnish a “C” Conduit Body & cord-grip, or FS junction-box & cord-grip nominally 12” above finish floor. Splice float leads within the conduit body or junction box.

PART 3 EXECUTION

5.01 EXAMINATION

- A. Verify length of float cable required. Running splices or field splicing in boxes other than those indicated on the drawings will not be allowed.

5.02 INSTALLATION

- A. Install equipment as detailed on drawings and per manufacturer's requirements.
- B. Stainless steel float bodies shall be grounded.
- C. Secure slack to cable hangers with corrosion resistant nylon cable ties.

5.03 TESTING

- A. Provide factory-trained manufacturer’s representative services to inspect completed installation, make all adjustment necessary to place system in trouble-free operation and instruct operating personnel in proper care and operation of equipment. Include four (4) hours additional services in order to instruct owner on use and maintenance of equipment.

END OF SECTION 16901

Section 16111 – Conduit and Raceway**PART 1 GENERAL****5.04 WORK INCLUDES**

- A. Work included in this section is conduits, raceways and fittings required for operation and maintenance of facility.

5.05 RELATED SECTIONS

- A. Division 11 – Equipment
- B. Division 13 – Special Construction
- C. Division 15 – Mechanical
- D. Section 16010 – General Electrical Requirements
- E. Section 16123 – Building Wire and Cable
- F. Section 16190 – Supporting Devices

5.06 REFERENCE TO STANDARDS

- A. Federal Specifications WW-C-581d
- B. Federal Specifications WW-C-540c
- C. Federal Specifications WC-1094-A
- D. ANSI C80.1
- E. ANSI C80.3
- F. ANSI C80.5
- G. UL Standard UL-1 Standard for Flexible Metal Conduit
- H. UL Standard UL-6 Electrical Rigid Metal Conduit – Steel
- I. UL Standard UL-6A Electrical Rigid Metal Conduit – Aluminum, Red Brass and Stainless Steel
- J. UL Standard UL-651 Standard for Schedule 40, 80, Type EB and a Rigid PVC Conduit and Fittings.
- K. UL Standard UL-651A Schedule 40 and 80 High Density Polyethylene (HDPE) Conduit.
- L. UL Standard UL-797 Electrical Metallic Tubing - Steel
- M. UL Standard UL-1479 Standard for Fire Tests of Penetration Firestops.
- N. NEMA RN1
- O. NEMA RN2
- P. NFPA 70 (NEC)

- Q. NEMA TC-2
- R. NEMA TC-3
- S. NEMA TC-7

5.07 DELIVERY, STORAGE AND HANDLING

- A. Conduits shall not be shipped loose, but shall be bundled by sizes. Threads of metal conduits shall be protected by plastic caps. Fittings shall be stored in boxes. All equipment shall be stored on pallets to prevent contact with earth and shall be covered with plastic sheeting to protect them from dirt and weather.

5.08 SUBMITTALS (SUBMIT ONLY ON TYPES APPLICABLE FOR PROJECT)

- A. Submit under provisions of Division 1.
- B. Schedule 40 Galvanized Rigid Steel Conduit
- C. PVC Coated Galvanized Rigid Steel Conduit
- D. Schedule 40 Aluminum Rigid Conduit
- E. Electrical Metallic Tubing (EMT)
- F. Rigid PVC Conduit
- G. Flexible Metal Conduit
- H. Liquid Tight Flexible Metal Conduit
- I. Explosion-proof Flexible Metal Couplings
- J. High-Density Polyethylene Conduit (Unit Duct)
- K. Fittings and Conduit Bodies
- L. Expansion/Deflection Fittings
- M. Lay-In Wireway
- N. Conduit Seals
 - 1. Conduit Fire Stopping
 - 2. Conduit Water Seals
 - 3. Conduit Explosion Proof Seals

5.09 QUALIFICATIONS

- A. All materials shall be purchased new from suppliers/manufacturers regularly engaged in the business of electrical conduit, ducts and fittings.

5.10 MAINTENANCE SERVICE (WARRANTY)

- A. All equipment shall be warranted to be free from defects in material and workmanship for a period of one year from date of substantial completion established by Owner.

PART 2 PRODUCTS

6.01 EQUIPMENT SPECIFICATION

Note that all types specified below may not be used on every project. Refer to project drawings for individual project requirements.

A. Schedule 40 Galvanized Rigid Steel Conduit:

Conduit shall be of heavy wall type fabricated from mild steel tubing and shall have a hot-dipped galvanized inner and outer coating, with a final coating of zinc chromate. Conduit and installation shall comply with all requirements in NEC Article 344. Mounting hardware shall be corrosion resistant, stainless steel, or galvanized steel.

B. PVC Coated Galvanized Rigid Steel Conduit:

PVC coated galvanized rigid steel conduit shall be Robroy Industries Plasti-Bond, or equivalent. PVC coating shall be a minimum of 40 mils in thickness and permanently fused to hot-dipped galvanized rigid steel conduit. A urethane inner coating shall be applied to the conduit interior and a clear urethane coating shall be applied over the galvanized threads. Conduit and installation shall comply with all requirements in NEC Article 344. Mounting hardware shall be corrosion resistant: PVC coated supporting devices with stainless steel hardware.

C. Schedule 40 Rigid Aluminum Conduit

Conduit shall be of 6063 aluminum alloy, T-1 temper (Former designation T-42). Rigid aluminum conduit shall be third-party listed for use in classified (hazardous) locations. Conduit and installation shall comply with all requirements in NEC Article 344. Do not utilize steel or iron conduit fittings with aluminum conduit. Mounting hardware shall be corrosion resistant: stainless steel or aluminum.

D. Electrical Metallic Tubing (EMT)

EMT shall be hot dip galvanized steel with an organic corrosion resistant coating and shall be produced in accordance with U.L. Standard 797, ANSI C80.3 and NEMA RN2. Fittings for EMT conduit shall be compression type only, set-screw type fittings shall not be utilized. Conduit and installation shall comply with all requirements in NEC Article 358. Mounting hardware shall be corrosion resistant: zinc, galvanized steel, aluminum or stainless steel.

E. Rigid PVC Conduit:

Conduit shall be Schedule 40 or Schedule 80, as noted on the drawings, PVC, 90°C, UL rated or approved equivalent. Material shall comply to NEMA Specification TC-2 (Conduit), TC-3 (Fittings-UL-514), and UL-651 (Standard for rigid nonmetallic conduit). Conduit and fittings shall carry a UL label (on each 10 foot length of conduit and stamped or molded on every fitting). Conduit and fittings shall be identified for type and

manufacturer and shall be traceable to location of plant and date manufactured. Markings shall be legible and permanent. Clean rework material, generated by manufacturer's own conduit production, may be used by same manufacturer, provided end products meet requirements of this specification. Conduit and fittings shall be homogeneous plastic material free from visible cracks, holes, or foreign inclusions. Conduit bore shall be smooth and free of blisters, nicks or other imperfections which could mar conductors or cables. Conduit, fittings and cement shall be compatible to assure system integrity and shall be as shown on project drawings, or equal. Conduit and installation shall comply with all requirements in NEC Article 352. Mounting hardware shall be corrosion resistant: nonmetallic support straps or PVC conduit clamps with stainless steel hardware, designed for the installation of PVC conduit, which allows the conduit to expand and contract freely over varying temperature changes.

F. Flexible Metal Conduit

Flexible metal conduit (Greenfield) shall consist of interlocking steel armor and shall comply with U.L. Standard 1 and 1479. Conduit and installation shall comply with all requirements in NEC Article 348.

G. Liquid Tight Flexible Metal Conduit (Non-Hazardous Areas):

Liquid tight flexible metal conduit shall consist of polyvinyl jacket over flexible hot dip galvanized steel tubing. Flexible conduit shall be completely sealed from liquids, dust, dirt and fumes, be resistant to oil, gasoline, grease and abrasion. Jacket shall also be sunlight resistant. Flexible conduit shall be U.L. listed and comply with Article 351 of NEC. Flexible conduit shall be Flexi-Guard Type UAG, as manufactured by O-Z/Gedney, or equal. Conduit and installation shall comply with all requirements in NEC Article 350.

H. Liquid Tight Flexible Non-Metallic Conduit (Non-Hazardous Areas):

Liquidtight Flexible Non-Metallic Conduit shall be non-conductive, non-corrosive, resistant to oil, acid, ozone and alkaline, and crush, abrasion and strain resistant. Conduit shall maintain internal I.D. even in tight radius bends. Conduit shall be UL Listed for use as indicated in Article 356 of the NEC, UL Listed for outdoor use, and sunlight resistant. Trade sizes 1/2", 3/4" and 1" shall be UL Listed for direct bury. Conduit shall be suitable for use at conduit temperatures of 80°C dry, 60°C wet and 60°C oil resistant as required by section 15-6 of ANSI/NFPA 79-1985 and UL 1660. Liquidtight non-metallic flexible conduit shall be Carlon Carflex Type LFNC-B, or equivalent.

I. Flexible Couplings w/stainless-steel braid (Hazardous Areas/Explosion Proof):

Flexible couplings used in hazardous areas shall be suitable for use in Class I, Div. I, Group D areas and shall comply with all requirements of Articles 500 and 501 of the NEC. Note: Due to corrosive environments, ALL explosion-proof flexible metal couplings shall be constructed with Stainless Steel braided construction over woven cotton braid impregnated with asphalt. Do NOT utilize bronze-braid explosion-proof flexible conduit as it is quickly corroded by hydrogen-sulfide gas. All explosion-proof

flexible couplings shall additionally be liquid tight and listed for wet locations. Explosion-proof flexible couplings shall provide a continuous electrical grounding path which meets, or exceeds, NEC & UL requirements. Explosion proof flexible conduit shall be Crouse-Hinds ECGJH#### -S516 (Male-to-Male) or ECLK#### -S516 Series (Male-to-Female), or equivalent, where # indicate manufacturer's code designation for coupling trade-size and length

J. High-Density Polyethylene (HDPE) Conduit (Unit Duct and Directional Bore)

Unit duct shall be installed with additions, options and exceptions as noted herein. Unless otherwise specified, the Polyethylene Duct shall be Schedule 40 and comply with the following:

1. NEMA TC-7 Smooth Wall Coilable Polyethylene Electrical Plastic Duct
2. ASTM D-3485 Standard specification for Smooth Wall Coilable Polyethylene (PE) Conduit (Duct) for preassembled wire and cable.
3. ASTM D-2477 Standard Specifications for Polyethylene (PE) Plastic Pipe, Schedules 40 and 80, Based on Outside Diameter
4. ASTM D-3350 Standard Specifications for Polyethylene Plastics Pipe and Fittings Materials
5. NEC Art 353 High Density Polyethylene Conduit; Type HDPE Conduit.
6. U.L. 651 Continuous length HDPE

Materials used for the manufacture of the polyethylene conduit and casing shall be high-density polyethylene that meets or exceeds a cell classification of 334430C (Black) or 334430E (Colored Shell) per ASTM D-3350. Recycled and reclaimed materials from outside the manufacturer's plant shall not be utilized in manufacture. Black material shall contain a minimum of 2% carbon black for long-term protection against UV degradation. The base resin used in the manufacture of the product shall contain a high-quality anti-oxidant package. The wall thickness shall be in accordance with ASTM D-2447. Conduit or casing shall be continuously marked with durable printing at intervals no greater than five (5) feet. Coils and reels shall have sequential footage marks. In order to prevent the entrance of dirt and water, the open ends of each length of reeled flexible duct, and all installed lengths prior to termination, shall be sealed by plastic caps. Polyethylene duct shall be Tamaqua, CPChem (Division of Chevron Phillips Chemical), Cablecon (by Integral Corp.) or equivalent. All fittings shall be specifically designed for use with polyethylene conduit. All terminations of polyethylene conduit to other conduit types shall be made utilizing fittings listed for the purpose. Solvent bonding of polyethylene conduit shall utilize American Polywater Corp. BonDuit Conduit Adhesive, or approved equivalent. Conduit and installation shall comply with all requirements in NEC Article 353.

K. Fittings and Conduit Bodies:

Unless otherwise specified, all fittings and conduit bodies shall be manufactured from the same type of material as the conduit system (aluminum, galvanized steel, PVC, etc.)

Field Modifications to Existing Rigid Metal Conduit Systems ONLY: Where

modifications to existing rigid conduit installations make threading of field cuts impossible, use Type HK series couplings by Thomas & Betts/Steel City, or equivalent.

L. Expansion and Deflection Fittings

Where noted on project drawings, or required by the nature of construction location, furnish conduit Expansion, Deflection or Expansion/Deflection Fittings. Expansion and deflection fittings shall be compatible with other conduit materials and be type AX (expansion), DX (deflection) or AXDX (expansion/deflection) as manufactured by O-Z/Gedney, or equivalent.

M. Lay-In Wireway:

Unless otherwise indicated on the drawings, lay-in wireway installed in dry (non-hosedown) interior areas shall be NEMA 1 hinge cover steel enclosed wiring trough. Lay-in wireway installed outdoors or in interior areas subject to hosedown or wet conditions shall be NEMA 3R, 4 or 4X as noted on the drawings. Wireway shall be sized as shown on drawings, as a minimum, or as required by NEC, and shall be as manufactured by Square D, Hoffman, or equivalent. Install all hinged wireways with hinges on bottom such that doors will not interfere with maintenance and installation when open.

N. Pull Cords

Each empty conduit shown or described on the drawings shall be furnished with a pull cord to facilitate future conductor installation. Cord shall consist of non-deteriorating, non-metallic, non-cotton construction such as polyester or nylon material. Minimum tensile strength of all pull strings shall be 200#. Leave minimum of 12 inches slack at each termination or end. Any references on project drawings to “pull wire” shall be interpreted as a pull cord as described herein.

6.02 SEALING

A. Fire Seal (Fire Stopping Material):

1. Fire stopping materials shall consist of commercially manufactured products capable of passing ASTM E-814 (UL 1479) Standard Method of Fire Test for Through Penetration Fire Stops.
2. Fire stopping materials shall maintain the rating of the wall, partition, ceiling or floor opening where penetration is made. Comply with NEC 300-21.
3. All fire-stopping materials shall be third-party classified.
4. Where sleeves are to be installed, the sleeve shall be heavy wall steel pipe sleeves, anchored to building construction and finished plumb with wall, ceiling, or floor lines.
5. Manufacturers:

- a. Chase Technology – CTC, PR-855.
 - b. Dow Corning – Silicone RTV Foam 3-6548.
 - c. Nelson – Flameseal.
 - d. Thomas & Betts – Flame Safe.
 - e. 3M – Fire Barrier.
6. Where applicable for the respective wall and its fire rating, smoke and fire stop fittings may be used in lieu of sealant as manufactured by OZ/Gedney, Series CFS.
- B. Thermal Seal:
1. Seal penetrations of thermally insulated equipment or rooms top prevent heat transfer.
- C. Moisture Seal:
1. When electrical conduits are installed in sleeves, core-drilled holes or box outs, seal between conduit and penetration of perimeter walls, ceilings or floors to prevent entry of water.
 2. Seal conduit penetrations of roof with flashings compatible with roof design and approved by Roofing System Manufacturer and Engineer.
 3. Seal annular space between conductors and conduit wall of all conduit terminations where conduit enters a building from below grade in order to block moisture migration into electrical equipment. In addition seal conduits entering electrical equipment located either interior or exterior that once installed condensation is created in the electrical equipment due the electrical system being connected to areas with a different temperature. Conduit moisture barrier material shall not harden and be compatible with both wire insulation and conduit materials. Installed product shall be easily removed for maintenance or modifications, regardless of the length of time material has been installed. Conduit moisture seal material shall be:
 - a. “Hydroblock” by WaterGuard Technology Products
16023 East Freeway
Channelview, Texas 77530-4365
Phone: (281) 862-0300
Fax: (281) 862-0314
 - b. American Polywater Corporation
Polywater Duct Sealant FST-250 Series
P.O. Box 53
Stillwater, MN 55082
Phone: (651) 430-2270
Fax: (651) 430-3634
 - c. O-Z/Gedney
Type DUX Water Sealing Compound
- D. Class I, Division 1, Group D Conduit Seals
1. Explosion proof conduit seals shall be suitable for use in Class I, Division 1, Group D classified location. Explosion proof conduit seals shall be Crouse-Hinds EYS or EZS Series, Appleton EYS, ESU, or EY Series, Killark ENY, EYS or EY Series, or O-Z Gedney EYA, EY, EZS Series explosion proof sealing fitting. Conduit seal shall

include Packing Fibers and Epoxy Sealing Compound to provide an explosion-proof seal. See also note in Part 3 regarding identification of “poured” conduit seals.

- E. Class I, Division 2 Conduit Seals
1. Conduit seals shall be Crouse-Hinds EYS or EZS Series, Appleton EYS, ESU, or EY Series, Killark ENY, EYS or EY Series, or O-Z Gedney EYA, EY, EZS Series. See also note in Part 3 regarding identification of “poured” conduit seals.
 2. Per NEC 501.15.B.1, conduit connections to enclosures required to be explosion-proof shall have a conduit seal in accordance with NEC 501.15.A.1.1 and A.3, this is, a Class 1, Division 1, Group D Conduit Seal. There shall be no unions, couplings, boxes or fittings between conduit seal and enclosure.
 3. Per NEC 501.15.B.2, in each conduit run passing from a Class I, Division 2 location into an unclassified location, the sealing fitting shall be permitted on either side of the boundary of such location within 10 ft of the boundary. There shall be no unions, couplings, boxes or fittings between conduit seal and the defined wall. Conduits shall be sealed to minimize the amount of gas or vapor within the Division 2 portion of the conduit from being communicated to the conduit beyond the seal. Such seals shall not be required to be explosion-proof but shall be identified for the purpose of minimizing passage of gases under normal operating conditions and shall be accessible.

PART 3 EXECUTION

7.01 INSPECTION

- A. All conduits shall be inspected for proper fit and finish, for out-of-round and for proper thickness. All burrs and flashing shall be removed. Conduit and fittings shall be clean and free of obstructions.

7.02 INSTALLATION

- A. Unless otherwise shown on the project drawings, minimum conduit trade-size shall be 3/4". Larger sizes shall be installed where noted or where required by NEC.
- B. In general, no aluminum conduit shall be cast in concrete or in direct contact with earth. Where such contact is found necessary or where specifically noted on project drawings, either coat all aluminum contact surfaces with a protective bituminous coating (such as Carboline Bitumastic 50 or 300M) or alternately substitute galvanized rigid steel conduit for the sections which are in contact with concrete or earth.
- C. Interior Conduit Applications:
1. Above Grade or Floor:
Rigid aluminum type unless otherwise noted on the project drawings.
 2. Below Grade or Floor:
Schedule 40 PVC or galvanized rigid steel at the Contractor’s option. Where interior conduits exit from below floor or grade to above grade furnish conduit transition between types no more than 6” above finish floor.
- D. Exterior Conduit Applications
1. Above Grade:
Rigid aluminum type unless otherwise noted on the project drawings. Where conduits exit to above grade transition to conduit type shall be no more than 6”

from penetration.

2. Below Grade:
 - a. PVC Schedule 80 unless otherwise noted.
- E. Moisture Seal of Below-Grade Conduits
 1. Seal annular space between conductors and conduit wall of all conduit terminations where conduit enters from below grade in order to block moisture migration into electrical equipment. Install product only after conductors have been installed, terminated and commissioned for service. Install moisture seal products per all manufacturers instructions and requirements.
- F. Conduit Sealing For Fireproofing
 1. Sleeves:
 - a. Install rigid metallic sleeves where exposed raceways pass through floors, walls (except exterior walls below grade) and ceilings.
 - b. Sleeve Diameter: Size sleeves to accommodate their through penetrating items and allow a minimum of a one (1”) inch void between the sleeve and the item of penetration.
 2. Seal openings in fire rated floors, ceilings and roofs:
 - a. Pack void with backing material and ends of the sleeve sealed with a minimum of one (1”) inch of a listed fire-resistive silicone compound to a depth required to meet the fire rating of the structure penetrated.
 - b. Install firestopping to meet the requirements of ASTM E-814
 - c. Install product in accordance with the manufacturer’s instructions.
- G. Conduit size and fill requirements shall comply with appropriate conduit fill tables in Annex C of NEC. It should be noted these are minimum requirements and larger conduit sizes or smaller fill requirements shall be used whenever specified or detailed on drawings.
- H. Flexible conduit shall be provided as a connection between each motor junction box (or any other piece of equipment subject to movement or vibration) and rigid conduit system. Liquid-tight and explosion-proof flexible conduit shall not exceed 3’ in length.
- I. Ream conduits only after threads are cut. Cut joints square to butt solidly into couplings. Where necessary to join two pieces of conduit and it is impossible to use standard coupling, use three piece conduit coupling. Use of running thread is prohibited. This applies to all rigid conduit installations, underground or otherwise. In order to comply with NEC Article 300.6(A), all rigid steel conduit shall have field-cut threads re-coated using an electrically conductive, corrosion-resistant compound, Thomas & Betts/Shamrock “Kopr-Shield” (a product of Jet Lube, Inc.), or equivalent.
- J. Make all joints in underground conduit watertight with approved joint compound. Temporarily plug conduit openings to exclude water, concrete or any foreign materials during construction. Clean conduit runs before pulling in conductors.
- K. Hickey hand-bends will not be acceptable for conduits one inch (1”) and larger. Use pre-manufactured factory elbows or bends fabricated with hydraulic bending machine. Field bending of all PVC conduit shall be accomplished with use of equipment approved by conduit manufacturer. Open flame bending equipment will not be acceptable.

- L. A run of conduit between outlet and outlet, between fitting and fitting or between outlet and fitting shall not contain more than the equivalent of four quarter turn bends (360°), including bends immediately at an outlet or fitting.
- M. At all conduit terminations furnish locknuts on both sides of enclosure plus an insulated bushing unless conduit termination is into a factory-threaded conduit opening or watertight (Myers-type) hub.
- N. All conduit terminations at NEMA 4 or 4X enclosures shall be made with watertight (Myers-type) hubs listed for the application.
- O. Do not run conduit below or adjacent to water piping, except where permitted by Owner's representative.
- P. Run exposed conduits parallel with walls and at right angles to building lines, not diagonally.
- Q. Support exposed PVC conduit runs on walls or ceiling every three feet (3') and support exposed rigid metal conduit runs on walls or ceiling every five feet (5') with stainless steel or PVC coated galvanized cast one hole straps, clamp backs and anchors. Provide lead shield insert anchors, with stainless steel round head machine screws, for concrete and brick construction. In wood construction, use stainless steel round head wood screws. Where steel members occur, drill and tap and use stainless steel round head machine screws.
- R. In brick construction, drill hole for insert near center of brick, not near edge or in mortar joint.
- S. Support two or more PVC exposed hanging parallel conduit runs every three feet (3') and support exposed rigid metal hanging parallel conduit runs every five feet (5') with trapeze hangers. Hanger assembly to consist of concrete inserts, threaded solid rod, washers, nuts and cross members nominally one and five-eighths inch (1-5/8") by one and five-eighths inch (1-5/8") non-metallic framing, as specified in Section 16190 - Supporting Devices. Anchor each conduit individually to cross members of every other hanger with cast one hole straps, clamps backs and proper sized stainless steel or non-metallic machine bolts and nuts.
- T. Perforated metal strapping of any kind is prohibited.
- U. Provide expansion and deflection fittings in all conduits which pass through or over building expansion joints. All expansion and deflection fittings shall be designed for, and compatible with, the conduit types on which they are installed.
- V. Grounding Electrode Conductors shall be installed in non-metallic PVC conduit or bonded to both ends of metallic conduit to comply with NEC 250.64.
- W. All conduit and fittings installed in Classified Areas shall be third part listed for the applicable Hazardous Location.
- X. Install explosion-proof conduit sealing fittings in conformance with the manufacturer's instructions. Per Article 501 Paragraph 501-5(c)(6) of the NEC, cross-sectional area for conductors installed in a conduit sealing fitting shall not exceed 25%, unless conduit sealing fitting has been specifically approved for a higher percentage of fill.

- Y. Identification of “poured” conduit seals: Conduit seal fill plugs shall be neatly spray painted red immediately following installation of fill material. Excess spray paint on surrounding surfaces shall be removed at the Contractor’s expense. The Engineer will use this means of identification to certify that the Contractor has installed conduit-seal fill materials and plugs in compliance with all U.L., F.M. and manufacturer’s requirements. Do not spray paint fill plugs of any spare or future conduit seals.

- Z. PVC coated galvanized rigid steel conduit shall be installed per manufacturer’s requirements, using tools specifically designed for installation of PVC coated galvanized rigid steel conduit. Any tools, hardware or installation methods which cause damage the PVC coating shall not be utilized. Do not install any material found damaged from shipping or handling. Any PVC coated conduit damaged during installation shall be immediately repaired to the satisfaction of the Owner’s authorized representative using patching materials and methods per manufacturer’s instructions. If, in the opinion of the Owner’s authorized representative, PVC coated galvanized rigid steel conduit is damaged beyond repair, the damaged portion(s) shall be removed and replaced at the contractor’s expense.

END OF SECTION 16111

SECTION 16123 – BUILDING WIRE AND CABLE**PART 1 GENERAL****7.03 WORK INCLUDES**

- A. Work included in this section is supply of wire and cable to provide a complete and operational electrical system.
- B. Any bid submitted to the Owner which contains cost adjustments for the current price of metals (copper and/or aluminum) will be rejected. Qualified bids in any form will not be considered.
- C. Unless otherwise specified or detailed on drawings, all wire and cable on this project shall be copper construction only.

7.04 RELATED SECTIONS

- A. Division 11 - Equipment
- B. Division 13 - Special Construction
- C. Division 15 - Mechanical
- D. Section 16010 - General Electrical Requirements
- E. Section 16111 - Conduit and Raceway
- F. Section 16170 - Grounding and Bonding

7.05 REFERENCE TO STANDARDS

- A. ANSI/NFPA 70 - National Electrical Code
- B. U.L Standard No. 44 - Thermoset-Insulated Wires and Cables.
- C. IPCEA Publication No. S-66-524.
- D. Federal Specification J-C-30B
- E. ASTM Specification B-8.

7.06 DELIVERY, STORAGE AND HANDLING

- A. Wire and cable shall be delivered on reels or coiled in boxes. Wire and cables shall be stored and handled to prevent damage to conductor and insulation.

7.07 SUBMITTAL REQUIREMENTS

- A. Submit under provisions of Division 1.
- B. Contractor shall submit for all cable types and sizes used on this project.

7.08 QUALIFICATIONS

- A. Wire and cable shall be manufactured and supplied by a company regularly engaged in business of furnishing wire and cable. If required by Owner's representative,

manufacturer shall submit a certification to a minimum experience of five years in manufacture of wire and cable.

7.09 MAINTENANCE SERVICE (WARRANTY)

- A. All equipment shall be warranted to be free from defects in material and workmanship for period of one year from date of substantial completion established by the Owner.

PART 2 PRODUCTS

8.01 EQUIPMENT SPECIFICATION

- A. RHW-2 / USE-2 WIRE

Unless otherwise noted on the drawings or specifications, all exterior cable shall be dual-rated type RHW-2/USE-2. Contractor should note that this applies to both direct buried cable and cable in conduit or duct.

Cable shall be 600 Volt rated, sized as indicated on the drawings. Cable shall comply with Underwriters Laboratories Standard U.L. 44 (for Type RHW-2) and U.L. 854 (for Type USE-2) and shall pass the IEEE 383, 70,000 BTU/hr and VW-1 Flame Tests. Cable insulation shall be abrasion, moisture, heat and sunlight resistant black cross-linked polyethylene (XLP). Cables shall be rated for use at 90°C in both wet and dry locations and be suitable for use in conduit, underground service entrance cable and direct burial applications.

- B. THHN/THWN

Unless otherwise noted on the plans or specifications, all interior power wiring installed under this project shall be dual rated type THHN/THWN.

Cable shall be 600 Volt rated, sized as indicated on the drawings. Cable shall comply with Underwriters Laboratories Standard U.L. 83. Cables shall be rated 90°C in dry locations 75°C in wet locations. Conductors shall be annealed copper.

- C. XHHW-2

Cable shall be 600 Volt rated, sized as indicated on the drawings. Cable shall comply with Underwriters Laboratories Standard U.L. 44, Federal Specification A-A-59544, and requirements of the National Electrical Code. Type XHHW-2 meets and exceeds all construction requirements of ICEA S-95-658 (NEMA WC 70) - Nonshielded 0 - 2 kV Cables, with testing frequencies based on UL requirements. Cables shall be rated for use at 90°C in both wet and dry locations. Conductors shall be annealed copper.

D. INSTRUMENTATION SHIELDED CABLE

(For use in Conduit)

Shielded instrumentation cable shall be used where required or shown on plans. Cable construction shall be #16 AWG tinned copper, polyethylene insulated, have #18 AWG stranded tinned copper drain wire and aluminum-polyester shield with 100% coverage. Overall jacket shall be polyvinyl Chloride (PVC). Cables shall be 60°C, 600 V rated and U.L. recognized.

1. 2-Conductor shielded instrumentation cable for use in conduit shall be Belden #8719, or equivalent.
2. 3-Conductor shielded instrumentation cable for use in conduit shall be Belden #8618, or equivalent.

E. INSTRUMENTATION SHIELDED CABLE

(For use in Cable Tray)

Shielded instrumentation cable shall be used where required or shown on plans. Cable construction shall be #16 AWG tinned copper, PVC/Nylon insulated, have #18 AWG stranded tinned copper drain wire and aluminum-polyester shield with 100% coverage. Overall jacket shall be polyvinyl Chloride (PVC). Cables shall be 60°C, 600 V rated and U.L. recognized as Type TC (UL 1277) for use in Cable Tray.

1. 2-Conductor shielded instrumentation cable for use in Cable Tray shall be Belden # 1118A, or equivalent.
2. 3-Conductor shielded instrumentation cable for use in Cable Tray shall be Belden # 1119A, or equivalent.

F. DEVICENET CABLE

DeviceNet Cable shall consist of two individually-twisted individually-shielded pairs with overall tape/braid shield. Overall jacket shall be Polyvinyl Chloride (PVC). Cable shall be suitable for both indoor and below grade applications in conduit. DeviceNet cable shall meet all ODVA (Open DeviceNet Vender Association) requirements.

1. DeviceNet Trunk (thick) cable shall be Belden #3082A, or equivalent.
2. DeviceNet Drop (thin) cable shall be Belden #3084A, or equivalent.

G. CATEGORY 6 CABLE

1. UTP Cable to be 23 AWG copper construction and Certified to TIA/EIA-568-B.2-1 requirements.
2. Cable shall be accommodate transmission speeds up to 4.8 Gb/s.
 - a. Riser cable shall be ITS/ETL Certified as CMP and listed as NEC type CMR per UL Standard 444. Riser cable shall be Belden DataTwist 4812 or equivalent.
 - b. Plenum cable shall be ITS/ETL Certified as CMP and listed as NEC type CMP per UL Standard 444. Plenum cable shall be Belden DataTwist 4813 or equivalent.

H. DATA HIGHWAY & DATA HIGHWAY PLUS

(“BLUE HOSE” / ALLEN-BRADLEY PLC NETWORK/)

Data Highway Plus network cable shall be Multi-conductor, t twinax (2 conductors), 18

AWG (for use in tray) or 20 AWG (for use in conduit) stranded tinned copper construction with Polyethylene insulation (PE), aluminum foil-polyester Tape shield with a 20 AWG stranded tined copper drain wire. Overall jacket shall be blue PVC.

- 1. For use in conduit, Data Highway & Data Highway Plus cable shall be Belden #9463, or equivalent.
- 2. For use in cable tray, Data Highway & Data Highway Plus cable shall be Belden #3072F, or equivalent.

I. CATV

Coaxial CATV signal cable shall be 75 Ohm, RG-6/U having 18 AWG solid copper core, polyethylene foam insulation, tape and braid shield, with overall black PVC outer jacket, Belden #1694A or equivalent. Terminate all coaxial cable with hexagonal or octagonal crimp-type connectors only. Screw-on type connectors will not meet this requirement.

J. Tray Cables

Where applicable for projects involving the installation of cable tray, all cables to be installed in cable tray shall be 600 Volt rated, and in conformance with NEC Article 336. All Tray Cables shall additionally be listed as Type “TC” and pass U.L VW-1 vertical flame test.

Specifications Writers: Include paragraph “E” ONLY if Fiber Optic cable is utilized on the project. Taylor as necessary for specific equipment requirements.

K. FIBER OPTIC CABLES (FO)

- 1. Multi-mode Breakout Riser Rated - ONFR
- 2. Nominal Operating Temperature –40°C to +85°C
- 3. 12 Fiber Construction around center strength member
- 4. Elastomeric PVC Black outer jacket suitable for indoor or outdoor use
- 5. 62.5/125 micron core/cladding
- 6. Attenuation: At 850 nm; 3.5 dB/km 220 MHz-km
 At 1310 nm; 1.0 dB/km 500 MHz-km
- 7. Optical Cable Corporation Part Number BX***-D-WLS-9KR or equivalent (where “***” indicates the number of individual fibers as noted on project drawings within each cable).

- L. Furnish and install fiber optic terminators (connectors) style SC or ST as required to match equipment. Connectors shall be designed for field assembly and be self-aligning and self-centering. Comply with manufacturers requirements. Include terminators on all fibers, including spares.

- M. Splice Closures: Splice closures shall protect the spliced fibers from moisture and to prevent physical damage. The splice closure shall provide strain relief for the cable and the fibers at the splice points.

8.02 COLOR CODING

- A. Color code conductor insulation for #10 AWG or smaller conductors. Color code conductors #8 AWG or larger with colored tape or colored insulation. Standard colors:

		240 V or			
	120/240V	208/120V	480V	240/120V	
	1 Phase	3 Phase	3 Phase	3 Phase	
	<u>3W</u>	<u>3 or 4W</u>	<u>3 or 4W</u>	<u>4W, □</u>	
Phase A	Black	Black	Brown	Black	
Phase B	Red	Red	Orange	Orange (high leg)	
Phase C	Blue	Blue	Yellow	Blue	
Neutral	White	White	Gray	White	
Ground	Green	Green	Green	Green	

- B. Intrinsically safe wiring shall be light blue color insulation per ANSI/ISA RP12.6 and NEC 504 or per respective equipment manufacturer’s recommendations.
- C. Control wiring insulation color shall be red.
- D. 120 VAC control wiring from a separate source (for example, 120 V control wiring from a control panel that supplies a remote located starter) shall be with yellow color insulation.
- E. 24 VDC wiring shall be Blue for Positive and White with Blue Stripe for Negative.

8.03 WIRE PULLING LUBRICANT

- A. Pulling lubricant shall be UL listed, water based, polymer solution. Lubricants containing waxes, soaps or combustible materials are not acceptable. Contractor shall verify the compatibility of the selected cable pulling lubricant and cable jacket materials proposed. Manufacturers/Lubricants shall be as follows, or equivalent:

1. American Polywater - Polywater J
2. Ideal Industries - ClearGlide
3. American Colloid - Poly-X
4. Buchanan - Quick Slip
5. ARNCO – HydraLube

8.04 SPLICES AND JOINTS

- A. Splices and joints shall be as described below, or approved equivalent.

- B. Interior applications:
1. #8 and smaller conductors:
 - a. Ideal “sing nut” type insulated connectors.
 - b. Scotchlok R, B, and Y type insulated connectors.
 2. #6 and larger conductors:
 - a. New construction: For straight line connections, use compression connector with rubber insulating cover or boot.
 - b. New construction: For “Tee” cable taps, use compression connector with rubber insulating cover or boot.
 - c. Existing construction: For taps in cabinets, gutters and other close locations, use O-Z/Gedney type XW & XWC, XTP & XTPC or, PMX & PMXC, or equivalent.
- C. Exterior applications
- Note that below grade splices in manholes, handholes and vaults **will not** be allowed on this project unless specifically shown on drawings. Conductors are to be pulled continuous end-to-end unless otherwise noted or directed by the Engineer in writing.
1. #8 and smaller conductors:
 - a. Twist-on connectors pre-filled with silicone-based sealant to protect against moisture and corrosion. Units shall be UL 486D listed as weatherproof, waterproof and suitable for direct burial. Units shall be Ideal Industries “Underground” #64 or King Innovation “Dryconn King 6 Blue” Filled Waterproof Connectors, or equivalent.
 2. #6 and larger conductors:
 - a. NSI/Polaris ISRW Series “Blue”
 - b. IlSCO Series USPA, DBK, SSK or PDSS

8.05 LINE MARKING TAPE

- A. Where required or noted on the drawings, line marking tape shall be installed as specified in Section 16118 - Duct Bank.

PART 3 EXECUTION

9.01 INSTALLATION (WIRE CONDUCTORS)

- A. Wire and cable shall be installed using accepted industry methods to prevent damage to conductors and insulation. Installation shall comply with all applicable sections of NEC regarding conduit fill.
- B. No splices shall be permitted in conduit bodies. All splices shall be made in junction boxes, control panels and cabinets provided for that purpose as detailed or required by need.
- C. Neatly train and lace wiring inside boxes, equipment and panelboards.
- D. Drawings are diagrammatic in showing circuitry routing between devices and equipment. Provide all phase conductors, neutrals, switched and unswitched legs, grounds, etc., as required for a complete and operational electrical system.
- E. All 120V circuits shall have individual neutral conductors. 120V circuits with “shared”

neutral conductor shall not be permitted.

- F. Minimum wire size shall be #12 unless otherwise noted. Where protected by 15A fuses, control wiring may be #14 AWG.
- G. All conductors shall be continuous without splices except at locations approved for the purposes of splicing.
- H. All wire sizes shall be stranded except where specifically approved otherwise.
- I. Intrinsically safe wiring shall be separated from non-intrinsically safe wiring in compliance with Article 504 of the NEC and ANSI/ISA Standard RP12.6. Intrinsically safe wiring insulation color shall be blue.
- J. All circuits shall be labeled in compliance with Section 16195 - Electrical Identification.
- K. Pulling eyes on conductors or a basket weave grip shall be used for pulling cable. Woven wire cable grips shall be used to pull all single conductor cable where pulling eyes are not available. Preferred method for pulling conductors is factory-installed eyes attached to conductors. All sharp points and edges on the hardware attaching the pulling rope to the cable shall be taped to prevent snagging or damaging the raceway.
- L. When a cable grip or pulling eye is used for pulling, the area of the cable covered by the grip or seal plus 6 inches shall be cut off, and discarded when the pull is completed. When pulling loops are used, the entire loop shall be cut off and discarded when the pull is completed.
- M. A non-binding type of swivel, or swivel connection shall be inserted between the pulling rope and the cable pulling eye, grip or loop to prevent twisting under strain and allow for free rotation of the cable during pulling.
- N. The pulling tension of any cable shall not exceed the maximum tension recommended by the cable manufacturer. Pulling mechanisms of both the manual and power types shall have the rated capacity clearly marked on the equipment. Cable shall be installed using either hand-tension or by use of specially-designed “cable-tuggers”. Any cable pulled through conduit using trucks, back-hoe’s, earthmoving equipment or similar apparatus will be rejected and will be replaced with new cable at the Contractor’s expense.
- O. Break-away shear-pins or other acceptable method of tension limitation shall be utilized on mechanical pulling equipment to prevent over-stressing cable during installation. To avoid insulation damage from excessive sidewall pressure at bends, the pulling tension, in pounds at a bend, shall not exceed 300 times the radius of the bend in feet.
- P. As soon as the cable is pulled into place, the pulling eyes, cable grips, or pulling loops shall be removed. On exterior pulls, the remaining cable ends shall be temporarily resealed with either a minimum of three (3) wraps of 2" Scotch #23 rubber splicing tape or heat-shrink caps. Exposed cable ends shall be wrapped in such a manner to prevent unintentional water entry. Cable ends or seals shall be installed prior to the end of the workday.
- Q. Cable shall not be bent to a radius of less than 4 times the overall diameter, including

installation apparatus.

- R. Cable supports and securing devices shall be installed to provide adequate support without deformation of the cable jackets or insulation.
- S. Cables shall be routed within manholes and vaults such that adequate working space is provided within the structure for cable splicing and for the installation of future cables.
- T. All damaged or rejected cable shall be removed from the project site and replaced at no additional expense to the project.

9.02 CONNECTIONS AND TERMINATIONS (WIRE CONDUCTORS)

- A. Identify each conductor in panelboards, junction or pull boxes, or troughs with a permanent pressure sensitive label with suitable numbers or letters for easy recognition. Identify control wiring at each end and in junction boxes with numeric wire number corresponding to control wiring diagram.
- B. Thoroughly clean wire before installing lugs and connectors.
- C. Make splices, taps and terminations to carry full ampacity of conductors without perceptible temperature rise.
- D. Terminate spare conductors with electrical tape, identify as “spares” and roll up in box.

9.03 TESTING (WIRE CONDUCTORS)

- A. Inspect wiring for physical damage and proper connection.
- B. All wire and cable shall be tested for continuity and short circuits prior to energizing circuits. Verify proper phasing, adjust as required.
- C. Comply with all applicable items in Section 16010 and 16950.

9.04 INSTALLATION (FIBER OPTIC CABLE)

- A. Unless noted otherwise, all conduits, ducts, and manholes for FO cable systems shall be installed as shown on drawings.
 - 1. No splices shall be permitted unless the length of cable being installed exceeds the maximum standard cable length available from manufacturer.
 - 2. Splices shall be made using the method recommended by the cable manufacturer. Splices shall be housed in a splice enclosure and shall be encapsulated with an epoxy or ultraviolet light cured splice encapsulant. All FO splices shall be field tested at the time of splicing. Fusion splices shall have less than 0.2 dB loss, and mechanical splices shall not be used. There shall be no more than one (1) splice per kilometer in any of the FO cables excluding terminations. All field splices shall be located in cable boxes. Sufficient cable shall be provided in each splicing location to properly splice the cables, and to provide extra cable for additional splices. All cable ends shall be protected at all times with end caps

except during actual splicing. During the splicing operations, means shall be provided to protect the unspliced portions of the cable from the intrusion of moisture and other foreign matter. All splices shall be done in hand holes provided and installed by the Contractor as required.

3. For cable installed in ducts and conduit a cable lubricant compatible with the cable sheathing material shall be used on all cables pulled. Pulling fixtures shall be attached to the cable strength members. If indirect attachments are used, the grip diameter and length shall be matched to the cable diameter and characteristics. If indirect attachment is used on cables having only central strength members, the pulling forces shall be reduced to ensure that the fibers are not damaged from forces being transmitted to the strength member. DURING PULLING THE CABLE PULL LINE TENSION SHALL BE CONTINUOUSLY MONITORED, AND SHALL NOT EXCEED THE MAXIMUM TENSION AS GIVEN BY THE CABLE MANUFACTURER. The mechanical stress placed upon a cable during installation shall be such that the cable is not twisted or stretched. A cable feeder guide shall be used between the cable reel and the face of the duct or conduit to protect the cable and guide it into the duct or conduit as it is played off the reel. As the cable is played off the reel, it shall be carefully inspected for jacket defects. Precautions shall be taken during installation to prevent the cable from being kinked or crushed and that the minimum bend radius of the cable is not exceeded at any time. Cable shall be hand fed and guided through each manhole and additional lubricant shall be applied at all intermediate manholes. When practicable, the center pulling technique shall be used to lower pulling tension. That is, the cable shall be pulled from the center point of the cable run towards the end termination points. The method may require the cable to be pulled in successive pulls. If the cable is pulled out of a junction box or manhole the cable shall be protected from dirt and moisture by laying the cable on a ground covering. Dynamometers or load-cell instruments shall be used to ensure that the pulling line tension does not exceed the installation tension value specified by the cable manufacturer. The mechanical stress placed upon a cable during installation shall be such that the cable is not twisted or stretched.

9.05 CONNECTIONS AND TERMINATIONS (FIBER OPTIC CABLE)

- A. Connectors: All fibers at each end of the cable shall have jumpers or pigtails installed of not less than 1 meter in length. All fibers at both ends of the cable shall have connectors installed on the jumpers. The mated pair loss, without rotational optimization shall not exceed 1.5 dB. The pull strength between the connector and the attached fiber shall not be less than 50 pounds.
- B. Identification and Labeling: The Contractor shall supply identification tags or labels for each cable. The labeling format shall be identified and complete record shall be provided to the Owner with the final documentation. Each cable shall be identified with type of signal being carried and termination points.

9.06 TESTING (FIBER OPTIC CABLE)

- A. An optical time domain reflectometer (TDR) test at 820 nanometers, of the FO cable on the reel prior to installation. The optical time domain reflectometer shall be calibrated to show anomalies of 0.2 dB as a minimum. Test data shall be recorded and furnished to

the Engineer. Cable tested with losses exceeding manufacturer's acceptable levels for new cable shall be rejected.

- B. A second time domain reflectometer test at 820 nanometers shall be performed on the FO cable after it is installed. The optical time domain reflectometer shall be calibrated to show anomalies of 0.2 dB as a minimum. If the optical time domain reflectometer test results are unsatisfactory, the FO cable segment is unacceptable.
- C. The unsatisfactory segments of cable shall be replaced with a new segment of cable at no cost to the Owner. The new segment of cable shall then be tested to demonstrate acceptability.

END OF SECTION 16123

SECTION 16170 – GROUNDING AND BONDING**PART 1 GENERAL**

- 9.07 WORK UNDER THIS ITEM INCLUDES THE ELECTRICAL GROUNDING AND BONDING OF THE SERVICE ENTRANCE GEAR, ELECTRICAL DISTRIBUTION EQUIPMENT, METALLIC RACEWAYS, METALLIC ENCLOSURES, UTILIZATION EQUIPMENT AND OTHER APPURTENANCES FOR THE WORK OR EQUIPMENT TO BE FURNISHED UNDER THIS PROJECT. IN GENERAL, ALL WORK SHALL MEET OR EXCEED THAT DEFINED IN ARTICLE 250 OF THE NATIONAL ELECTRICAL CODE NEC/NFPA 70.
- 9.08 THIS SPECIFICATIONS SECTION NEITHER REPLACES ANY NEC REQUIREMENTS, NOR ARE ANY NEC REQUIREMENTS NOT SPECIFICALLY IDENTIFIED CONSIDERED DELETED FROM THE SCOPE OF WORK. ITEMS LISTED IN THIS SECTION ARE FURNISHED TO EITHER AUGMENT, OR EXCEED THOSE ESTABLISHED BY NEC.
- 9.09 WORK INCLUDES
- A. Equipment grounding conductors
 - B. Grounding Electrodes
 - C. Grounding Electrode Conductors
 - D. Bonding
- 9.10 RELATED SECTIONS
- A. Section 16010 – General Electrical Requirements
 - B. Section 16671 – Surge Protective Devices (SPD)
- 9.11 REFERENCE TO STANDARDS
- A. Article 250; ANSI/NFPA 70 - National Electrical Code (NEC)
 - B. NFPA 780 – Standard for the Installation of Lightning Protection Systems
- 9.12 DELIVERY, STORAGE AND HANDLING
- A. Ground rods shall be tie-wrapped together and stored away from contact with the earth.
 - B. Exothermic welds and hardware items shall not be shipped loose but shall be in boxes, labeled with material and equipment enclosed. Boxes shall be stored away from contact with earth and shall be protected from weather.
- 9.13 SUBMITTALS
- A. Submit under provisions of Division 1
 - 1. Ground rods
 - 2. Exothermic welding components
- 9.14 QUALIFICATIONS (RESERVED)
- 9.15 QUALITY ASSURANCE (RESERVED)

9.16 REGULATORY REQUIREMENTS (RESERVED)

9.17 COORDINATION

- A. Installation of all Grounding and Bonding shall be coordinated with other trades and Sub-Contractors. Special attention is required for installation of Concrete-Encased Electrodes within structural footings.

9.18 MAINTENANCE SERVICE (WARRANTY)

- A. All equipment shall be warranted to be free from defects in material and workmanship for a period of one year from date of substantial completion established by the Owner.

9.19 EXTRA MATERIALS (SPARE PARTS) (RESERVED)

PART 2 PRODUCTS

10.01 MANUFACTURERS (RESERVED)

10.02 EQUIPMENT SPECIFICATION

- A. Ground rods shall be UL listed, single-piece, 3/4" diameter by 10' long copper-clad steel with minimum 10 mil copper cladding.

All buried connections of grounding and bonding components shall be via exothermic weld only. Clamp or compression grounding connections below grade will be rejected and replaced at Contractor's expense.

- B. Exothermic Welding Equipment Manufacturers
 1. Erico – Cadweld
 2. Continental Industries – Therm-O-Weld
 3. Hagar – Ultraweld
- C. Grounding conductors shall be 600 volt, same insulation type as used for phase conductors, green in color unless otherwise noted.
- D. Grounding electrode conductors in contact to earth shall be bare, stranded, annealed copper. Grounding Electrode Conductors shall be the larger of that detailed on the project drawings, specified herein or as required by NEC.

PART 3 EXECUTION

11.01 EXAMINATION (RESERVED)

11.02 PREPARATION (RESERVED)

11.03 INSTALLATION

- A. A continuous grounding system shall be provided throughout the facility. The Contractor shall furnish and install all grounding and bonding as required per NEC and all Local Codes, whether or not specifically shown on the project drawings.
- B. Except for separately derived systems, a single-point ground system is intended throughout the facility. So-called “Multi-point”, “independent”, “clean” or “separate” grounding systems that are not inter-bonded to the single-point facility system do not comply with NEC, are unsafe, and will be rejected.
 - 1. On occasion, supplemental driven ground rods may be required on the project drawings. All such supplemental ground rods are to be bonded to the equipment grounding conductor and are NOT intended to indicate any separation of, or isolation from, the facility grounding system.
- C. Equipment ground conductors (green insulated) shall be used solely for grounding and bonding purposes and be kept entirely separate from grounded neutral conductors (white insulation), except where bonded at the Service Entrance equipment.
 - 1. The system Neutral and Ground conductors shall be bonded together through the Main Bonding Jumper in the Service Entrance Equipment only.
 - 2. Unless otherwise directed on the project drawings, Grounding Electrode Conductors shall terminate on the Neutral Bus within the Service Entrance equipment.
 - 3. The Main Bonding Jumper within the Service Entrance equipment shall be accessible for visual inspection.
- D. Bond the system Neutral and Ground within Utility-owned KWH metering or Current-Transformer (C.T.) Cabinets ONLY if specifically required by the serving Utility. Otherwise, bond the system neutral and the ground in Service Entrance Equipment as described below.
- E. Service Entrance Equipment Grounding and Bonding
 - 1. Furnish grounding bushings on all metallic service conduits entering Service Entrance Equipment. Bond each bushing to Neutral bus in the Service Entrance Equipment as required by NEC Article 250.92 and 250.102C.
 - 2. The System (Main) Bonding Jumper shall be installed within the Service Entrance Equipment and shall connect the Neutral Bus to the Ground Bus.
 - a. The Main Bonding Jumper shall consist of either a U.L. Listed bonding link furnished by the Service Equipment manufacturer or a copper bonding conductor sized to requirements in NEC Article 250.28D.
 - b. Do not re-bond Neutral and Ground downstream unless required by special conditions, such as those described in NEC Article 250.32.
- F. Grounding Electrode System

1. As a minimum, the Grounding Electrodes shall comply with NEC Articles 250.52 and 250.53. Where present at each new building or structure, all available Grounding Electrodes defined in NEC Article 250.52A1 thru A4 shall be interconnected to form the Grounding Electrode System.
2. Per NEC Article 250.68A, the Grounding Electrode System shall be installed in such a manner that each connection point may be visually inspected, unless encased by concrete or earth.
3. Per NEC Article 250.64, Grounding Electrode Conductors shall be installed without splice between Service Entrance Equipment Neutral bar and Grounding Electrodes. Where required due to distance or construction, splicing shall be permitted by means of exothermic welding only. Irreversible “H” and “C” type compression connectors shall NOT be utilized for Grounding Electrode Conductors.
 - a. Where exposed or visible, all Grounding Electrode Conductors (regardless of size) shall be protected from physical damage using non-metallic conduit, such as Schedule 40 PVC. Extend protective conduit as close as practical to the Grounding Electrode. Any metallic conduits installed by the Contractor for grounding electrodes must be bonded at both ends per NEC Article 250.64E.
 - b. Where a copper Grounding Electrode System Bus-Bar is indicated on the project drawings, it shall sized as noted but no less than ¼”T x 2”W x 24”L.. Size of the single copper Grounding Electrode Conductor between the Service Entrance Neutral Bus and the Grounding Electrode System Bus-Bar shall be the larger of that shown in NEC Table T250.66 or as noted on the project drawings.

Connection of Grounding Electrode Conductors to a Grounding Electrode System Bus-Bar shall be through the use of listed compression-type lugs bolted to the Bus-Bar.
4. Grounding Electrode Conductors shall be individually installed from the Service Entrance Neutral Bus (or Grounding Electrode System Bus-Bar) to the respective Grounding Electrode. “Looping” of Grounding Electrode conductors (extending a suitably-sized single grounding electrode conductor from electrode-to-electrode) shall NOT be utilized without written approval from the Engineer.
5. Connection of Grounding Electrode Conductors to individual Grounding Electrodes shall comply with NEC Article 250.70.
 - a. Connection at all Grounding Electrodes shall be by use of exothermic welding. Clamp or compression connection connections shall NOT be utilized without written approval from the Engineer.
 - b. Below-grade ground rod and associated ground wire shall be clean and dry before performing the exothermic weld. Verify that the proper size and type of exothermic weld kit is used before beginning work
 - c. Exothermic welds shall be left exposed for inspection and approval before backfilling or otherwise concealing. Any unacceptable exothermic welds shall be redone, including any necessary replacement material

(ground rods, ground wires, etc.) as needed to provide an accepted exothermic weld.

6. Non-Metallic conduits containing grounding electrode conductors shall not be supported with metal clamps that completely encircle the conduit. Use nylon nuts, bolts, straps and/or reinforced fiberglass or premium grade plastic resin strut support with non-metallic hardware as manufactured by Aickinstrut, or equivalent.
7. All of the following shall be interconnected, where available:
 - a. Bond metallic underground water piping in direct contact with earth for no less than 10 feet per NEC Article 250.52A1. Size of the copper bonding jumper shall be the larger of that shown in NEC Table T250.66, or as noted on the project drawings. Installation shall comply with NEC Article 250.53. Connection shall be made at a point less than 5 feet from where the metallic water piping enters the facility. Furnish bonding around removable equipment (water meters, etc.) per NEC Article 250.68B.
 - 1) Note that NEC Article 250.53D2 requires a Supplemental Grounding Electrode when a metallic underground water pipe is the sole Grounding Electrode. The Supplemental Grounding Electrode shall be one of those described in NEC Articles 250.52A2 through 250.52A7. See also paragraph 16170-3.03F8 below.
 - b. Metal frames of building or structure shall be bonded per NEC Article 250.52A2. Size of the copper bonding jumper shall be the larger of that shown in NEC Table T250.66, or as noted on the project drawings. Installation shall comply with NEC Article 250.53.
 - c. Furnish concrete-encased electrodes (commonly called “Ufer” ground) per NEC Article 250.52A3 and install per NEC Article 250.53.
 - 1) The size of the copper conductor which is the sole connection to the concrete-encased electrode shall be the larger of that shown on the project drawings or #4 AWG.
 - 2) The Concrete-Encased Electrode (CEE) shall be no less than #4 rebar (½” diameter) with a minimum length of 20 feet long placed in bottom of concrete footing encased by no less than 2” of concrete in direct contact with earth.
 - 3) Within the concrete encasement, connect the grounding electrode conductor to the re-bar by means of exothermic weld, Cadweld, or equivalent. Compression connections will not be accepted as an alternate termination method of connection within the concrete envelope.
 - 4) **The Contractor shall provide all necessary coordination between the Sub-Contractors and trades for the implementation of this item before concrete is placed.**

- 5) Do not use Insulated (plastic or epoxy coated) re-bar for concrete-encased electrodes. If the structural construction requires insulated or plastic-coated re-bar, add a minimum of 20 feet bare, non-coated re-bar to create the Grounding Electrode.
 - 6) For installations that may structurally utilize re-bar smaller than #4, tie-wrap a minimum of 20' length of no smaller than #4 AWG bare copper Grounding Electrode to the re-bar in the bottom of the footing prior to installation of concrete.
- d. Furnish a Grounding Electrode Ground-Ring only where specifically noted on the project drawings. Ground-Ring shall comply with NEC Article 250.52A4 requirements and be installed per NEC Article 250.53. Where utilized, all Ground-Rings must encircle the entire facility (form a closed-loop). Size of the copper Grounding Electrode Conductor which is the sole connection to the ground-loop shall be the larger of that shown on the project drawings or #2 AWG.
8. On projects where the only Grounding Electrode listed in NEC Article 250.52A through 250.52D is a metallic underground water pipe, it must be supplemented by another grounding electrode per NEC Article 250.53D2. Unless directed otherwise, the supplemental grounding electrode shall be a driven ground field.
 - a. Ground field shall consist of a triangle 10 feet on each side, with a driven ground rod at each vertex of the triangle. Size of the copper Grounding Electrode Conductor, and the bonding jumpers between all ground rods, shall be the larger of that shown on the project drawings or #6 AWG.
 - b. If required due to space constraints, furnish two (2) ground rods a minimum of 10 feet apart. Deviations from the triangular-shaped ground field shall require written approval by the Engineer prior to installation.
- G. All metallic raceways, boxes, enclosures, etc. shall include an insulated equipment ground conductor. Due to corrosion, metallic raceway and conduit connectors alone WILL NOT be considered as meeting this requirement. The Equipment Grounding Conductor shall positively bond all electrical components and utilization equipment to the facility ground system.
 - H. All metallic boxes used for electrical equipment shall include listed grounding screws or lugs. No more than one grounding conductor shall be installed per lug location unless lug is listed for multiple conductors.
 - I. The largest factory-scored concentric conduit knockouts shall be used to provide conduit bonding to NEMA 1 & 3R enclosures.
 1. If required, provide a conduit reducing hub for the specific conduit size terminated.
 - J. Equipment Grounding Conductors shall be sizes as shown in NEC T250.122, but no less than #12 AWG.

- K. Where “isolated” ground receptacles are shown on the project drawings, furnish a separate, insulated, equipment grounding conductor directly between the supply panelboard ground bus and the “isolated” ground outlet. Equipment grounding conductors for “isolated” ground outlets shall not be extended or looped from other outlets or equipment.
- L. Isolated, exposed metal conduit segments (e.g. within manhole or handhole) shall be bonded with a bare copper conductor sized from NEC T250.122. Bonding jumper size shall be based upon the largest ampacity circuit contained within.
- M. Bonding of metallic components of manhole and handhole frames and lids as well as all exposed metal conduit sections of underground duct bank is covered under Specifications 16118 “Exterior Underground Duct Bank”.
- N. All other exposed metal piping (e.g. air, fire-protection, natural gas, metallic process piping etc.) and exposed structural steel not used as a Grounding Electrode shall be bonded to the Grounding Electrode System per NEC Article 250.104. Size of the copper bonding jumper shall be no smaller than that shown in NEC Table T250.66.
- O. All communications systems described in NEC Chapter 8 shall be bonded to system ground. Installation shall comply with NEC Article 250.94 and Articles 800, 810, 820 and 830. Size of the copper bonding jumper shall be #6 AWG unless otherwise noted on the project drawings.
- P. General Requirements for Separately Derived Systems (e.g. Two-Winding Transformers)

Solidly-Grounded Separately-Derived Systems shall be installed per NEC Article 250.30 requirements. In general, the following shall apply for solidly-grounded two-winding transformers unless specifically directed otherwise on the project drawings.

1. Primary Equipment Ground conductor shall terminate on transformer ground lug “G”.
 2. Install the transformer “X0-G” link, or system bonding jumper, within the transformer housing only. Where the System Bonding Jumper consists of a field-installed copper conductor, it shall be sized to NEC Table 250.66 but not less than 12½% of the total cross-sectional area of the secondary phase conductors.
 3. Secondary Neutral conductors shall be terminated on transformer “X0” Lug.
 4. Secondary Equipment Ground conductors shall be terminated on transformer ground lug “G”.
 5. Bond the transformer Neutral “X0” to the nearest grounding electrode in accordance with Article 250.30A7 of the NEC. The grounding electrode conductor shall be sized per Table 250.66, "Grounding Electrode Conductor for Alternating-Current Systems of the latest edition of NEC. Grounding Electrode conductor shall be installed in either non-metallic conduit (Schedule 40 PVC) or bonded at both ends of metallic conduit per NEC Article 250.64E.
 6. Neutral and Ground Bus in all downstream equipment shall be kept isolated. Do not re-bond downstream unless required by special conditions, such as those described in NEC Article 250.32.
- Q. On-Site Generation (e.g. Standby or Emergency Engine-Generators)

Unless otherwise noted on the project drawings, on-site generators are NOT to be installed as a separately derived system. Unless specifically shown otherwise on the project drawings, DO NOT bond Neutral and Ground at the generator.

1. Separate Neutral conductors plus separate Equipment Ground conductors shall be extended between distribution equipment (typically a 3-Pole Transfer Switch) and engine-generator system.
2. Generator Equipment Ground conductor shall be terminated on generator ground lug “G”.
3. Generator Neutral Conductors shall be terminated on generator Neutral lug “X0”.
4. DO NOT install “X0-G” bonding strap at generator. Contractor shall field-inspect generator and remove the “X0-G” jumper if found installed by factory prior to shipping.
5. Unless otherwise shown on the project drawings, the Transfer Switch will be a 3-Pole device switching the phase-conductors only. Unless the Transfer Switch the Service Entrance Equipment, the isolated Generator Neutral is to pass un-switched through the 3-Pole ATS and terminate on the Service Entrance “XO” Neutral Bus.
6. The Generator Ground conductor shall be terminated on the Service Entrance system Ground bus or Ground lug “G”.
7. The system Neutral-Ground bond is to be installed at one location at the Service Equipment ONLY. All downstream equipment shall keep Neutral and Ground conductors isolated and insulated from each other.

11.04 INTERFACE WITH OTHER SYSTEMS

(Where used on the project)

- A. Interface with Surge Protective Devices installed under section 16671.
- B. Lightning Protection Systems shall be bonded per NEC Article 250.106. All Lightning Protection Systems shall be bonded to facility Grounding Electrode system on facility exterior. Isolated grounding for Lightning Protection Systems will not be allowed.

11.05 MANUFACTURER’S FIELD SERVICES (RESERVED)

11.06 TESTING

- A. As described in Specifications Section 16950.
- B. All grounded metal cases and parts associated with electrical equipment shall be tested for continuity with ground system.
- C. If requested, testing shall be performed in the presence of the Owner’s representative.
- D. Provide a copy of all testing reports to Engineer for record purposes.

END OF SECTION 16170

SECTION 16190 – SUPPORTING DEVICES**PART 1 GENERAL****11.07 WORK INCLUDES**

- A. Strut-type framing for conduit and equipment supports
- B. Cable Rack saddle-type supports
- C. Anchors and Fasteners

11.08 RELATED SECTIONS

- A. Section 16010 – General Electrical Requirements

11.09 REFERENCE TO STANDARDS

- A. ANSI/NFPA 70 - National Electrical Code.
- B. NECA - National Electrical Contractors Association.
- C. ASTM No. A570 G33
- D. ASTM No. A-123
- E. ASTM No. A-525

11.10 DELIVERY, STORAGE AND HANDLING

- A. Stored conduit and equipment supports shall not be in contact with earth, but shall be on pallets or other above-grade supports. Conduit and equipment supports shall be covered to minimize exposure to weather.
- B. Anchors and fasteners shall be stored in their original containers in a clean, dry place. They shall not be exposed to weather.

11.11 SUBMITTALS

- A. Submit under provisions of Section 01300
- B. Product Data: Provide manufacturer's catalog data for fastening systems and supports.
- C. Manufacturer's instructions: Include application conditions and limitations for use stipulated by Product testing agency specified under Regulatory Requirements. Include instructions for storage, handling, protection, examination and installation of Product.

11.12 QUALIFICATIONS (RESERVED)**11.13 QUALITY ASSURANCE (RESERVED)****11.14 REGULATORY REQUIREMENTS**

- A. Conform to requirements of ANSI/NFPA 70.
- B. Furnish products listed and classified by Underwriters Laboratories, Inc., as suitable for purpose specified and shown.

11.15 COORDINATION (RESERVED)

11.16 MAINTENANCE SERVICE (WARRANTY)

- A. All equipment shall be warranted to be free from defects in material and workmanship for a period of one year from date of substantial completion established by the Owner.

11.17 EXTRA MATERIALS (SPARE PARTS) (RESERVED)

PART 2 PRODUCTS

12.01 MOUNTING STRUT

- A. Where utilized, strut-type metal framing shall be provided to mount and support electrical equipment and enclosures as indicated on the drawings.
- B. Strut-type supports shall be either aluminum or stainless steel construction. Unless specifically identified for use on the drawings, painted or factory coated steel, galvanized steel or non-metallic strut are not acceptable alternates to this requirement. Use stainless steel on all project locations where strut is in direct physical contact with earth.
- C. Unless specifically noted to be Type 316 Stainless Steel only, Stainless Steel strut-type metal framing may be Type 304 or Type 316 Stainless Steel.
- D. Aluminum strut-type metal framing shall be Type 6063-T6 Aluminum.
- E. All mounting hardware shall be stainless steel.
- F. Manufacturers:
 - 1. Unistrut: P-1000 EA (Aluminum), P-1000 SS (Stainless Steel)
 - 2. B-Line: B22AL (Aluminum), B24SS (Stainless Steel)
 - 3. Equivalent meeting specifications

12.02 CABLE RACKS

- A. Cable racks within manholes, handholes and vaults shall be non-metallic saddle type construction as manufactured by Underground Devices, Inc.; Northbrook, IL, or equivalent. All mounting hardware shall be stainless steel.

PART 3 EXECUTION

13.01 EXAMINATION

- A. Examine all supports and fasteners for straightness, rust and corrosion. Do not use any equipment that is not straight or is rusted or corroded.

13.02 PREPARATION

- A. All equipment shall be clean at time of installation. Remove all burs.

13.03 INSTALLATION

- A. Install products in conformance with manufacturer's instructions and as detailed in drawings.
- B. Provide anchors, fasteners and supports in accordance with NECA Standard of Installation. Do not use spring steel clips or clamps except as noted in Section 16190-3.03H.
- C. Do not fasten supports to pipes (except where detailed on drawings), ducts, mechanical equipment (except where detailed on drawings), or conduit.
- D. Install surface mounted cabinets, enclosures and panelboards with a minimum of four anchors.
- E. Provide materials, sizes and types of anchors, fasteners, and supports necessary to carry loads of equipment and conduits. Consider weights of equipment and conduit when selecting products.
- F. Provide all necessary hardware, such as floor flanges, in order to install equipment as specified or as shown on the drawings.
- G. Include knee-braces and stiffeners as necessary to provide rigid support such that equipment does not bounce or sway.
- H. Use spring-lock washers under all nuts.

13.04 INTERFACE WITH OTHER PRODUCTS (RESERVED)

13.05 MANUFACTURER'S FIELD SERVICES (RESERVED)

END OF SECTION 16190

SECTION 16195 – ELECTRICAL IDENTIFICATION**PART 1 GENERAL****13.06 WORK INCLUDES**

- A. This section includes field-installed nameplates, labeling and identification methods for electrical equipment, components and wiring.

13.07 RELATED SECTIONS

- A. Section 16010 - General Electrical Requirements\

13.08 REFERENCE TO STANDARDS

- A. ANSI/NFPA 70 - National Electrical Code

13.09 DELIVERY, STORAGE AND HANDLING**13.10 SUBMITTALS**

- A. Submit under provisions of Section 01300.
- B. Product Data: Provide catalog data for nameplates, labels and markers.
- C. Manufacturer's Instructions: Indicate application conditions and limitations of use stipulated by Product testing agency specified under Regulatory Requirements. Include instructions for storage, handling, protection, examination, preparation and installation of Product.
- D. During course of construction, Contractor shall submit Wiring Identification Tables, listing wire marker identification schedules of all proposed wiring and terminations.

13.11 QUALIFICATIONS (RESERVED)**13.12 QUALITY ASSURANCE (RESERVED)****13.13 REGULATORY REQUIREMENTS**

- A. Conform to requirements of ANSI/NFPA 70.

13.14 COORDINATION (RESERVED)**13.15 MAINTENANCE SERVICE (WARRANTY) (RESERVED)****13.16 EXTRA MATERIALS (SPARE PARTS) (RESERVED)****PART 2 PRODUCTS****14.01 MANUFACTURERS (RESERVED)****14.02 EQUIPMENT SPECIFICATION**

- A. Nameplates and legend plates shall be engraved three-layer laminated plastic, black letters on white background. Legends (wording) shall be as detailed on drawings or as directed by Owner's representative .
- B. All wire markers installed on electrical equipment above grade shall be weatherproof and water resistant. Wire identification labeling, whether factory applied or written in the field, shall utilize an adhesive that does not soften or weaken over time. Sleeve or tubing type labels may be utilized as an alternate. Paper adhesive-backed wire markers will be rejected and replaced at the Contractor's expense. Wire marker labels shall be as manufactured by Brady, or equivalent.
- C. All wire markers installed below grade in manholes, handholes or vaults shall be waterproof. Markers shall be non-corroding plastic clip-on sleeve type construction. Markers shall be permanently factory-printed such that label identification will not deteriorate due to time or contact with water. Wire markers used below grade shall be Brady Clip-Sleeve, or equivalent.
- D. Provide and install Safety Stripe Tapes on finished floors around electrical gear noting clearances required per NEC Article 110.26. Tape shall be minimum 2" in width with alternating black/yellow striping. Tape shall be Scotch/3M #5702 or equivalent.

PART 3 EXECUTION

15.01 EXAMINATION (RESERVED)

15.02 PREPARATION

- A. Degrease and clean surfaces to receive nameplates, legend plates and markers.

15.03 INSTALLATION

- A. Secure nameplates and legend plates to equipment using screws or adhesive.
- B. Nameplates or legend plates shall be provided for all disconnects, enclosed starters, control panels, transformers, level meters, flow meters and recorders.
- C. Wiring Device identification labels shall be furnished and installed on all wiring device cover plates per Specifications Sections 16141-3.01O and 16141-3.01P.
- D. Contractor shall develop the Wiring Identification Tables to be used for ALL wiring terminations on this project, and shall submit Tables for review and comment by Owner's Representative prior to installation of any conductors or cables.
- E. Provide wire markers for ALL wires and terminations. By "all", this is intended to include, but not be limited to, all terminations at distribution panelboards, motors, valves, heaters, fan coils, heat pumps, fans, dampers, all MCC terminations, instrumentation & controls, terminal blocks and strips, etc. Wire identification shall be unique to wire that is marked or to terminal that wire lands upon. Identification of a run of wire from termination to termination shall be same throughout run.
- F. Provide wire markers in all manholes, handholes and vaults.
- G. Include markers labeled "SP" on all spare conductors.

15.04 INTERFACE WITH OTHER PRODUCTS (RESERVED)

15.05 MANUFACTURER’S FIELD SERVICES (RESERVED)

15.06 AS-BUILT WIRING IDENTIFICATION TABLE

- A. Upon completion of project, Contractor shall provide five copies of as-built Wiring Identification Table. This table shall list **ALL** circuits installed as part of this work and shall give identification of **ALL** wires and terminations as installed and marked.

Table shall include routing of **ALL** conductors installed in the project from end-to-end including each conduit, manhole, handhole and vault through which each conductor passes. Include and identify all spare conductors.

END OF SECTION 16195

SECTION 16950 – TESTING ELECTRICAL SYSTEMS**PART 1 GENERAL****15.07 RELATED DOCUMENTS**

- A. Drawings and general provisions on Contract, including General and Supplementary Conditions and Division 1 Specification Sections, apply to work of this Section.
- B. Contractor shall note that this section shall be considered a Supplement to testing requirements outlined or described in other sections of these specifications.

15.08 WORK INCLUDES

- A. Extent of Work as required by the Drawings and these Specifications

15.09 RELATED WORK

- A. Specified elsewhere:
 - 1. Section 16010 - General Electrical Requirements
 - 2. Section 16123 - Building Wire and Cable
 - 3. Section 16160 - Cabinets and Enclosures
 - 4. Section 16170 - Grounding and Bonding
 - 5. Section 16185 - Mechanical Equipment Wiring
 - 6. Section 16220 - Motors (600 Volts and below)
 - 7. Section 16441 - Enclosed Switches
 - 8. Section 16481 - Enclosed Motor Controllers

15.10 QUALITY ASSURANCE

- A. Regulatory Requirements
 - 1. Governing Codes:
 - a. NFPA 70 – National Electrical Code (most current issue)

15.11 SUBMITTALS

- A. Submit under provisions of Division 1.
 - 1. Test Reports:
 - a. Test of entire electrical system as noted herein. Submit to the Engineer in triplicate.

PART 2 PRODUCTS**16.01 MATERIALS**

- A. Furnish all equipment, tools, manpower, and labor to perform specified testing.

PART 3 EXECUTION**17.01 TESTING**

- A. After wires and cables are in place and connected to devices and equipment, the system shall be tested for short circuits, improper grounds, and other faults. When fault condition is present, the trouble shall be rectified, then re-tested. Where cable is found defective or damaged, it shall be removed and replaced in entirety; do not field repair. Cost for correction shall be considered incidental to the project.
- B. All wiring devices and electrical apparatus furnished under this contract, when ground or shorted on any integral “live” part, shall be removed and the trouble rectified by replacing all defective parts and materials. Cost of correction is considered incidental to the project.
- C. All feeder cables and other power distribution apparatus shall have a Megger resistance test conducted to determine that insulation resistance is not less than that recommended by the manufacturer, or as noted below.

Unless otherwise recommended by the manufacturer, insulation resistance testing shall meet or exceed the following on 600 Volt equipment utilizing 500 Volt resistance test instrument:

Conductors.....	50 Meg-Ohms
Motors.....	5 Meg-Ohms
Switchboards, MCC's and Panelboards.....	25 Meg-Ohms
Power Transformers.....	5 Meg-Ohms

- D. Contractor shall furnish all tests and shall provide all test equipment, meters, instruments, cable connections or apparatus necessary for performing tests as specified herein. All costs for testing shall be considered incidental to this item and will not be paid for separately.
- E. Examine connections to equipment for proper phase relationships. Rotate phase conductors as necessary in order to correct.
- F. All motors shall be tested under Article 16220. All motors shall be tested for correct direction of rotation. Run tests on all motors shall be tested for correct direction of rotation. Run tests on all motors and verify that proper overload devices have been installed. Coordinate this task with motor supplier.
- G. Testing of Ground System
 - 1. Each and all grounded cases and metal parts associated with electrical equipment shall be tested for continuity of connection with the ground bus system by the Contractor in the presence of the Engineer or his representative.
 - 2. All grounding electrode conductors brought in from the ground field shall be tested for satisfactory continuity and by resistance measurement between the electrical equipment ground bus and the ground field. The grounding path shall not exceed 0.010 ohms.
 - 3. Each Ground Field shall be tested for resistance to earth a “three-terminal” or “fall-of-potential” test as described in IEEE Standard #81. As an alternate, a specially designed clamp-on instrument such as AEMC Model 3710 (now superseded by Model 6416) or 3730 (now superseded by Model 6417) may be used if found acceptable to the engineer. Based upon measured field data, the Contractor shall

calculate the ground field resistance and furnish record copies to the Engineer and Owner for record. In no case shall the ground field resistance exceed 25 ohms. If the resistance is found to be higher than 25 ohms, one additional rod shall be driven with a minimum separation equal to the length of the ground rod used and connected in parallel with the rod under test.

4. Exterior ground field resistance testing shall not be measured during unusually wet weather and should be performed during normal weather and soil conditions. Any tests incorrectly performed or not performed to the satisfaction of the engineer will be repeated. Costs for all such re-testing shall be considered incidental to the project.
5. All specified maximums and minimums of this specifications must be met. Complete test records of all tests shall be made and shall show resistance values obtained and calculations of same, showing method of test and calculation.

17.02 CORRECTION OF DEFECTS

- A. When tests disclose any unsatisfactory workmanship or equipment furnished under this contract, correct defects and retest. Repeat tests until satisfactory results are obtained.
- B. When any wiring or equipment is damaged by tests, repair or replace such wiring or equipment. Test repaired items to ensure satisfactory operation.

18.01 METHOD OF MEASUREMENT

No direct measurements will be made for the items in SP-13. They are just requirements to be followed for electrical items for this project.

18.02 BASIS OF PAYMENT

No direct payments will be made for the items in SP-13. They are just requirements to be followed for electrical items for this project.

END OF SECTION SP-13