

ELEVATION AT E. ABUT.

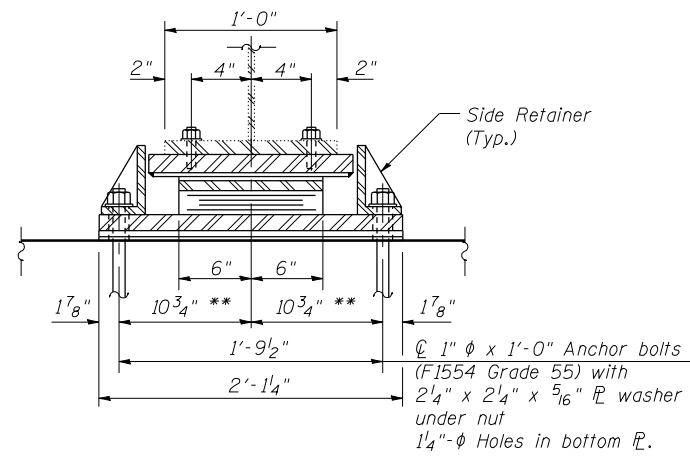

SECTION A-A

** See Sheet 18 of 26 for Bolt Placement

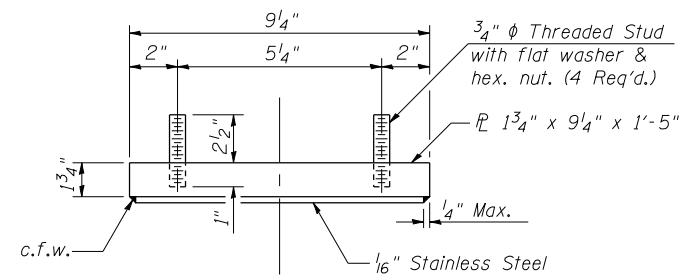

TOP BEARING ASSEMBLY

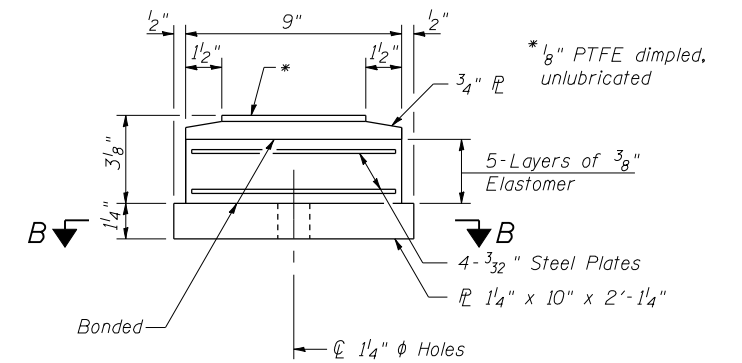

BOTTOM BEARING ASSEMBLY

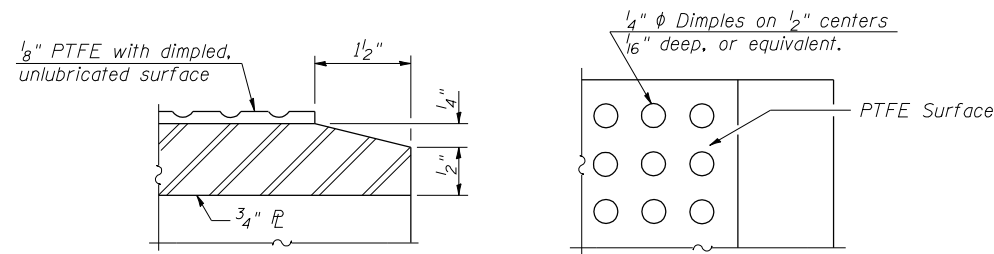

SECTION THRU PTFE

PLAN-PTFE SURFACE

TYPE II ELASTOMERIC EXP. BRG.

(5 at East Abutment)

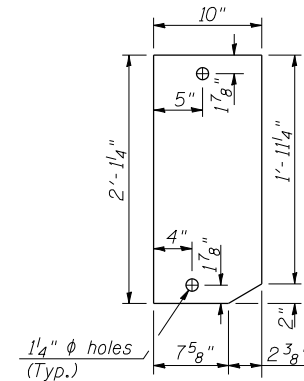

SECTION B-B

(Showing Bottom Plate)

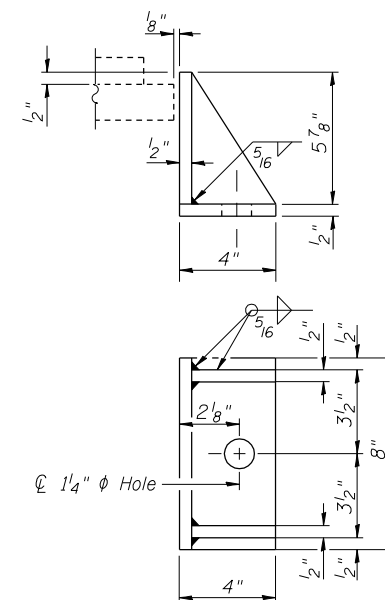

SIDE RETAINER

Equivalent rolled angle with stiffeners will be allowed in lieu of welded plates. (E. Abut.)

Notes:

Shim plates shall not be placed under Type I Bearing Assembly.

Anchor bolts shall be ASTM F1554 all-thread (or an Engineer-approved alternate material) of the grade(s) and diameter(s) specified. The corresponding specified grade of AASHTO M314 anchor bolts may be used in lieu of ASTM F1554.

Drilled and set anchor bolts shall be installed according to Article 521.06 of the Standard Specifications.

Side retainers and other steel members required for the elastomeric bearing assembly shall be included in the cost of Elastomeric Bearing Assembly, Type I and Elastomeric Bearing Assembly, Type II.

Anchor bolts for Type II bearings shall be placed in holes drilled in the concrete through holes in the bottom bearing plate after members are in place. Side retainers shall be placed after bolts are installed.

The 1/8" PTFE sheet shall be bonded directly to the top steel plate with a two-component, medium viscosity epoxy resin, conforming to the requirements of the Federal Specification MMM-A-134, Type I. The bond agent shall be applied on the full area of the contact surfaces.

Bonding of 1/8" PTFE sheet during vulcanizing process will be permitted provided the process and method of adjusting assembly height is approved by the Engineer.

See sheet 22 of 26 for Side Retainer details for Pier 1.

Two 1/8" adjusting shims shall be provided for each bearing in addition to all other plates or shims and placed as shown on bearing details.

BILL OF MATERIAL

Item	Unit	Total
Elastomeric Bearing Assembly, Type I	Each	10
Elastomeric Bearing Assembly, Type II	Each	5
Anchor Bolts, 1"	Each	30
Furnishing and Erecting Structural Steel	Pound	3,500

INTERIOR GIRDER MOMENT TABLE				
		0.4 Sp. 1 or 0.6 Sp. 3	Pier 1 & 2	0.5 Sp. 2
I_s	(in ⁴)	9760	13898	9760
$I_c(n)$	(in ⁴)	26098	-	26098
$I_c(3n)$	(in ⁴)	18938	-	18938
S_s	(in ³)	542	749	542
$S_c(n)$	(in ³)	804	-	804
$S_c(3n)$	(in ³)	722	-	722
ϕ	(k/')	0.90	0.93	0.90
$M \phi$	(k)	233	504	235
$s \phi$	(k/')	0.20	0.20	0.20
$M_s \phi$	(k)	58	96	68
$M \phi$	(k)	466	318	524
M_I	(k)	126	81	126
$\phi_3 [M \phi + I]$	(k)	987	665	1083
M_o	(k)	1661	1645	1807
M_u	(k)	3170	-	3170
$f_s \phi$ non-comp	(ksi)	5.2	8.1	5.2
$f_s \phi$ (comp)	(ksi)	1.0	1.5	1.1
$f_s \phi_3 [M \phi + M_I]$	(ksi)	14.7	10.7	16.3
f_s (Overload)	(ksi)	20.9	20.3	22.6
f_s (Total)	(ksi)	-	26.4	-
VR	(k)	59	-	45

INTERIOR BEAM REACTION TABLE			
	Abut.	Pier	
$R \phi$	(k)	25.4	88.9
$R \phi$	(k)	42.8	50.3
R_I	(k)	11.4	12.8
R_{Total}	(k)	79.6	152.0

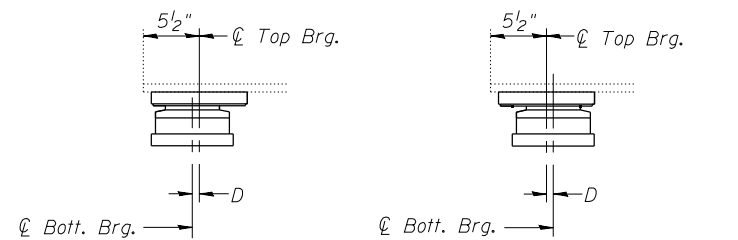

SETTING ANCHOR BOLTS AT EXP. BRG.

$D = 1/8$ " per each 100' of expansion for every 15° temp. change from the normal temp. of 50°F.