

PROPOSED TYPICAL SECTIONS
STA. 345+34 TO 347+52

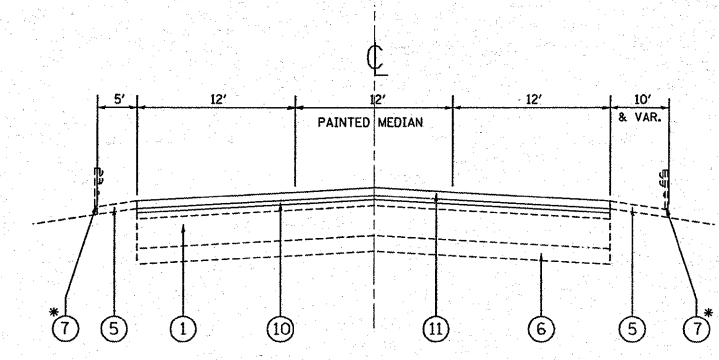

PROPOSED TYPICAL SECTIONS
STA. 378+28 TO 380+90

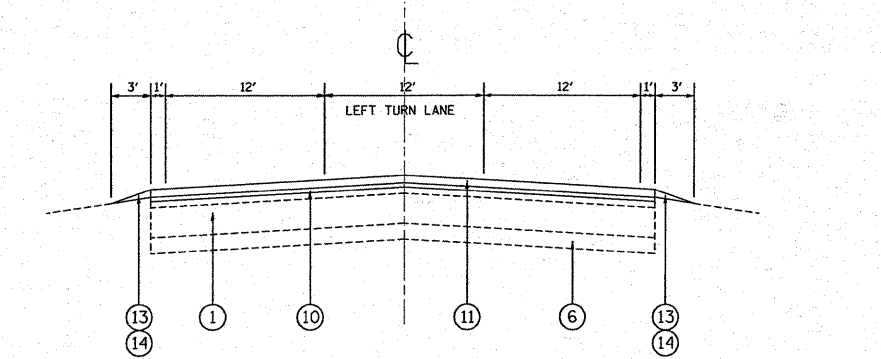

PROPOSED TYPICAL SECTIONS
STA. 347+52 TO 355+69

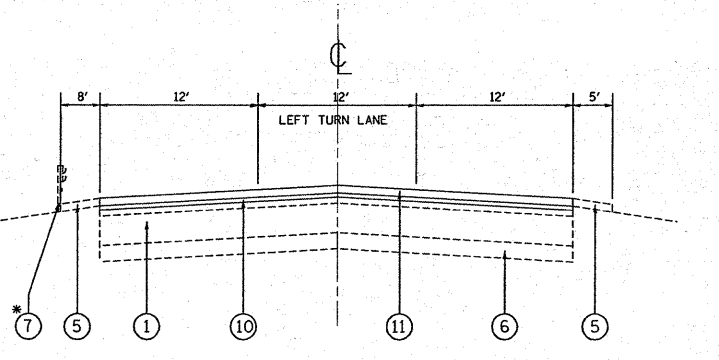

PROPOSED TYPICAL SECTIONS
STA. 382+23 TO 387+32

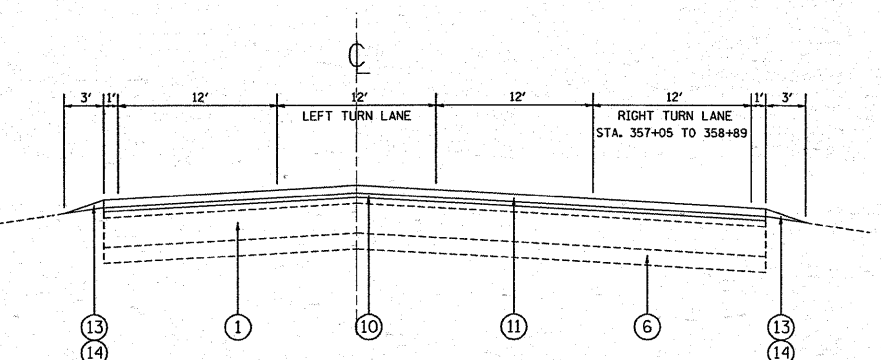

PROPOSED TYPICAL SECTIONS
STA. 355+69 TO 362+22

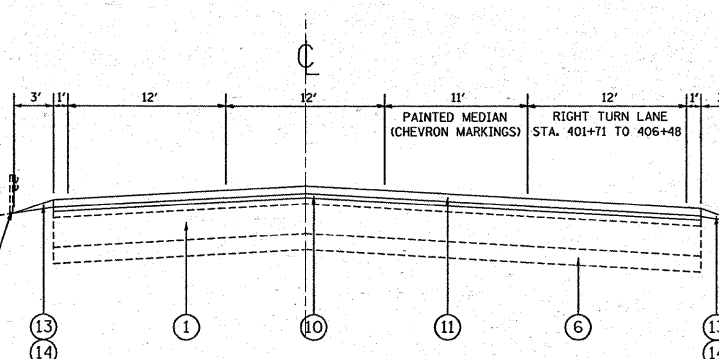

PROPOSED TYPICAL SECTIONS
STA. 401+71 TO 408+26

LEGEND:

- ① EXIST. P.C.C. PAVEMENT, ±9"
 - ② EXIST. HOT-MIX ASPHALT SURFACE, ±3" (AFTER MILLING)
 - ③ EXIST. COMBINATION CONCRETE CURB AND GUTTER, TYPE B-6.24
 - ④ EXIST. AGGREGATE SHOULDER, 3'
 - ⑤ EXIST. HOT-MIX ASPHALT SHOULDER
 - ⑥ EXIST. STABILIZED SUB-BASE
 - ⑦ EXIST. GUARDRAIL
 - ⑧ PROP. HOT-MIX ASPHALT SURFACE REMOVAL, 2 1/4"
 - ⑨ PROP. HOT-MIX ASPHALT SURFACE REMOVAL, 2 1/2"
 - ⑩ PROP. POLYMERIZED LEVELING BINDER (MACHINE METHOD), IL-4.75, N50, 3/4"
 - ⑪ PROP. HOT-MIX ASPHALT SURFACE COURSE, MIX "D", N70, 1 1/2"
 - ⑫ PROP. POLYMERIZED HOT-MIX ASPHALT SURFACE COURSE, MIX "F", N90, 1 3/4"
 - ⑬ PROP. GRADING AND SHAPING SHOULDERS
 - ⑭ PROP. AGGREGATE WEDGE SHOULDER, TYPE B
- R CURB AND GUTTER REMOVAL AND REPLACEMENT