

LEGEND:

- ① EXIST. P.C.C. PAVEMENT, ±9"
- ② EXIST. HOT-MIX ASPHALT SURFACE, ±3" (AFTER MILLING)
- ③ EXIST. COMBINATION CONCRETE CURB AND GUTTER, TYPE B-6.24
- ④ EXIST. AGGREGATE SHOULDER, 3'
- ⑤ EXIST. HOT-MIX ASPHALT SHOULDER
- ⑥ EXIST. STABILIZED SUB-BASE
- ⑦ EXIST. GUARDRAIL
- ⑧ PROP. HOT-MIX ASPHALT SURFACE REMOVAL, 2 1/4"
- ⑨ PROP. HOT-MIX ASPHALT SURFACE REMOVAL, 2 1/2"
- ⑩ PROP. POLYMERIZED LEVELING BINDER (MACHINE METHOD), IL-4.75, N50, 3/4"
- ⑪ PROP. HOT-MIX ASPHALT SURFACE COURSE, MIX "D", N70, 1 1/2"
- ⑫ PROP. POLYMERIZED HOT-MIX ASPHALT SURFACE COURSE, MIX "F", N90, 1 3/4"
- ⑬ PROP. GRADING AND SHAPING SHOULDERS
- ⑭ PROP. AGGREGATE WEDGE SHOULDER, TYPE B

R CURB AND GUTTER REMOVAL AND REPLACEMENT

***EXIST. GUARDRAIL LOCATIONS**

- STA. 277+60 TO 279+52 (WB)
- STA. 277+60 TO 279+63 (EB)
- STA. 289+69 TO 293+47 (WB)
- STA. 289+73 TO 292+40 (EB)
- STA. 302+72 TO 304+24 (EB)
- STA. 303+47 TO 305+00 (WB)
- STA. 378+27 TO 391+41 (WB)
- STA. 378+38 TO 380+90 (EB)
- STA. 391+70 TO 402+90 (WB)
- STA. 403+17 TO 409+28 (WB)

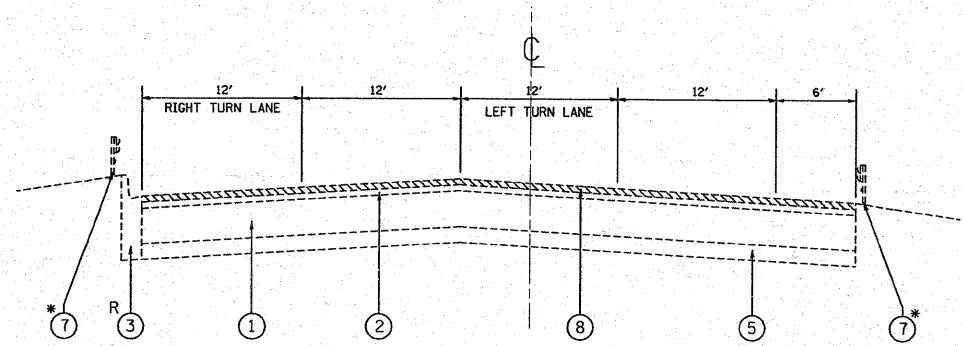

EXISTING TYPICAL SECTIONS
STA. 277+02 TO 284+65

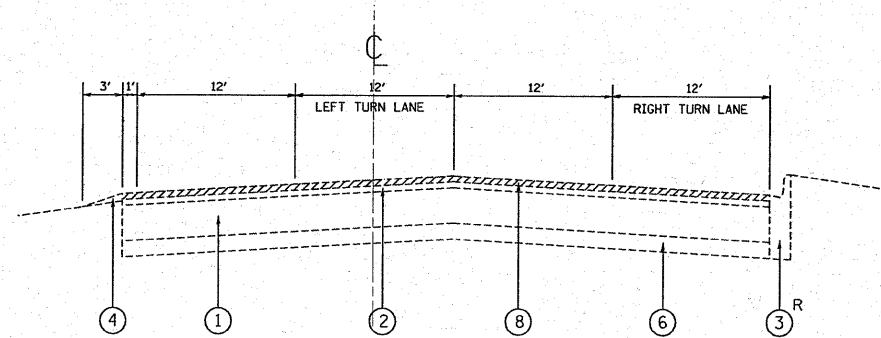

EXISTING TYPICAL SECTIONS
STA. 316+01 TO 318+30

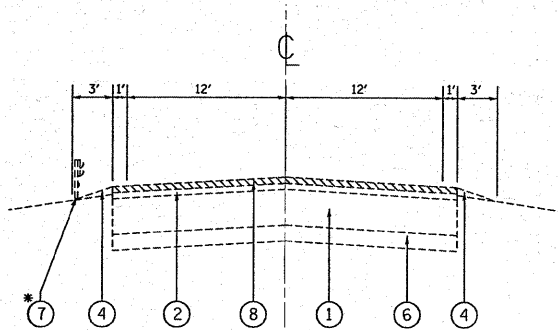

EXISTING TYPICAL SECTIONS
STA. 284+65 TO 311+98
STA. 336+11 TO 345+34
STA. 362+22 TO 378+28
STA. 387+32 TO 401+71

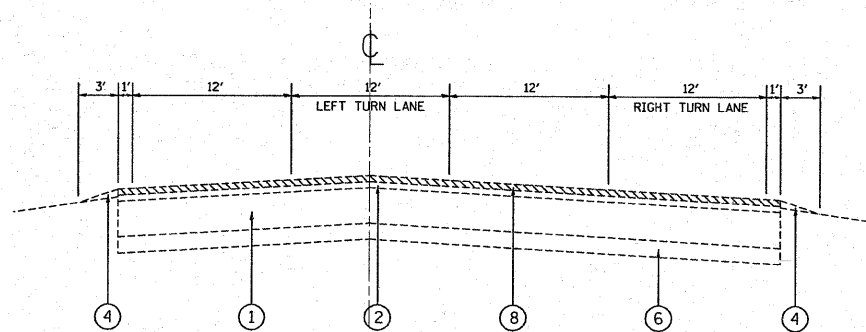

EXISTING TYPICAL SECTIONS
STA. 324+39 TO 328+30

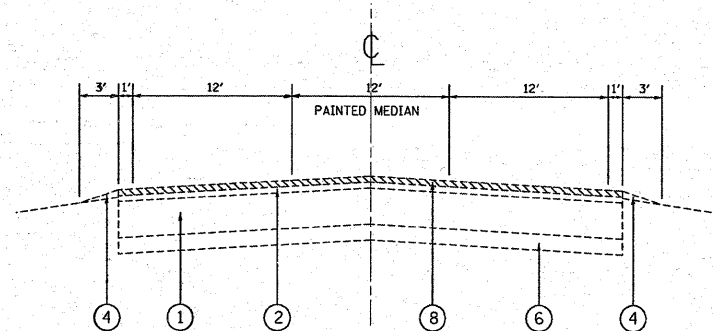

EXISTING TYPICAL SECTIONS
STA. 311+98 TO 316+01
STA. 319+36 TO 324+39

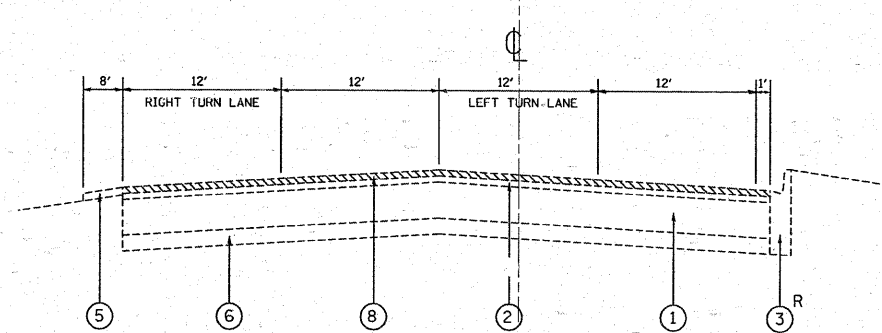

EXISTING TYPICAL SECTIONS
STA. 329+61 TO 336+11

FILE NAME =	USER NAME = steedpo	DESIGNED -	REVISED -	STATE OF ILLINOIS DEPARTMENT OF TRANSPORTATION	EXISTING TYPICAL CROSS SECTIONS				F.A.P. RTE.	SECTION	COUNTY	TOTAL SHEETS	SHEET NO.
c:\pwwork\pwwork\steedpo\d0120487\0131199-plt-plan.dgn		DRAWN -	REVISED -		F.A.P. 351	3349 RS-2	COOK	34	4				
PLOT SCALE = 50.0000' / IN.		CHECKED -	REVISED -		CONTRACT NO. 60F97								
PLOT DATE = 2/10/2009		DATE -	REVISED -		FED. ROAD DIST. NO. 1 ILLINOIS FED. AID PROJECT								
				SCALE: SHEET NO. OF SHEETS STA. TO STA.									