

STATE OF ILLINOIS  
DEPARTMENT OF TRANSPORTATION

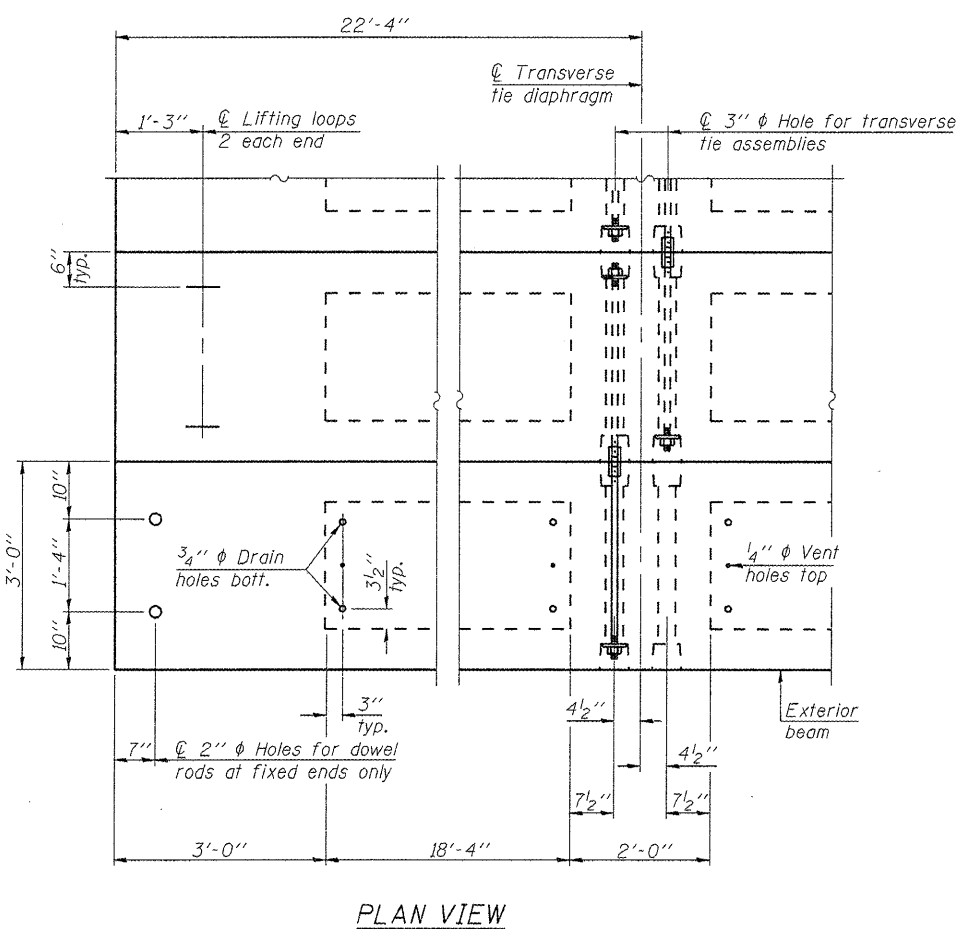
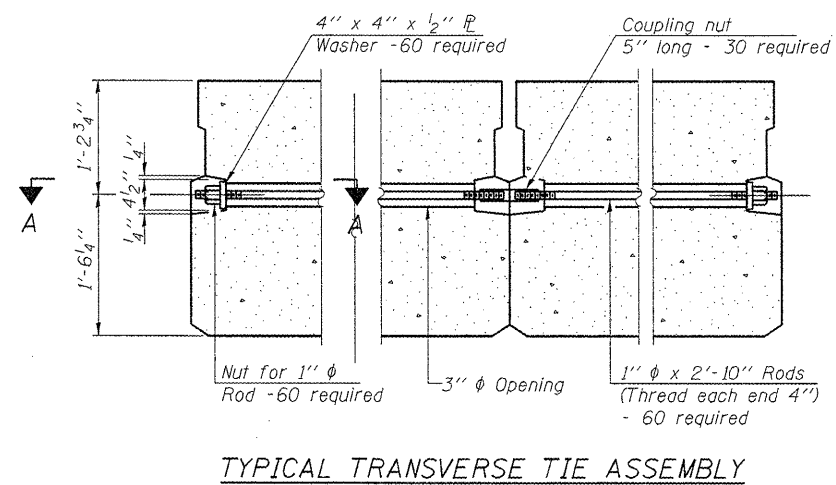
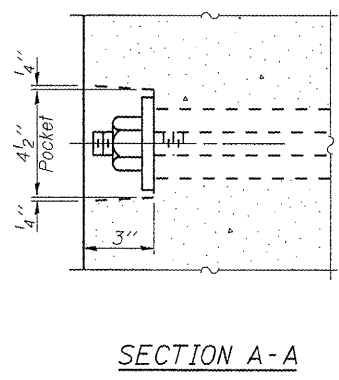
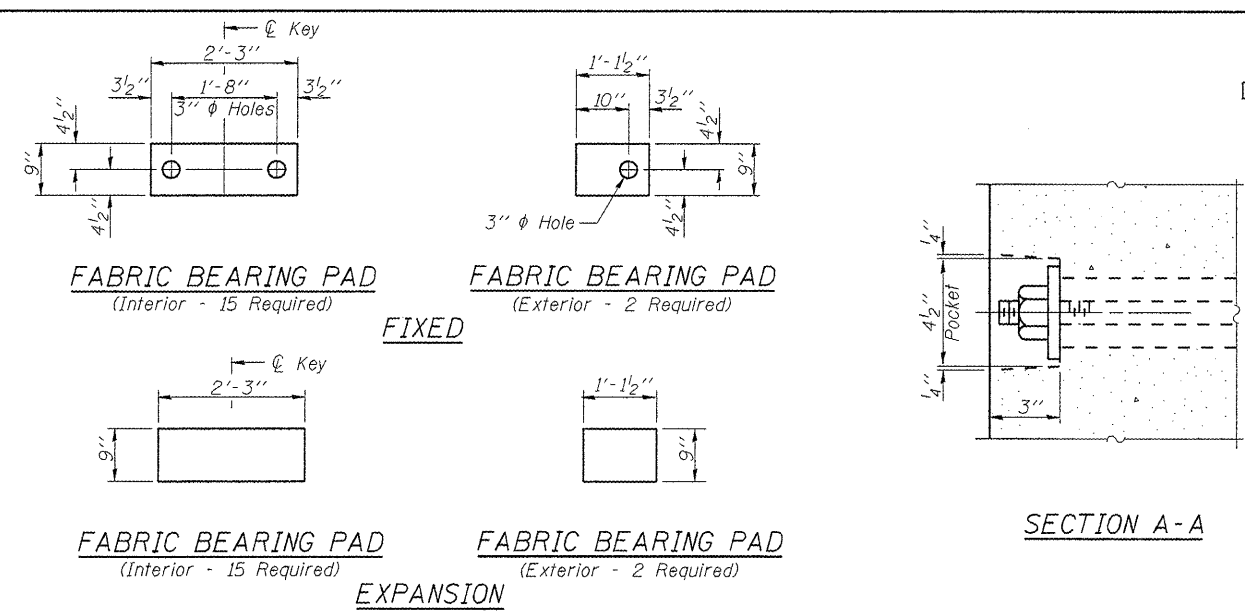

Note: Connect beams in pairs with the transverse tie configuration shown.

DESIGNED -	BPS
CHECKED -	GSP
DRAWN -	BPS/MJB
CHECKED -	GSP

**NOTES**

Prestressing steel shall be uncoated high strength, low relaxation 7-wire strand, Grade 270. The nominal diameter shall be 1/2 inch and the nominal cross-sectional area shall be 0.153 sq. in. The 1 inch diameter rods in the transverse tie assembly shall be tightened to a snug fit and the threads set. Pockets on exterior faces of bridge shall be filled with grout after transverse tie assembly is in place.

Reinforcement bars shall conform to ASTM A 706, Grade 60. (See Special Provisions). Two 1/8 inch fabric adjusting shims of the dimensions of the exterior bearing pad shall be provided for each bearing pad location.

A minimum 2 1/2 inch diameter lifting pin shall be used to engage the lifting loops during handling. Corrosion Inhibitor, per Article 1020.05(b)(12) and 1021.06 of the Standard Specifications, shall be used in the concrete for precast prestressed concrete deck beams.

Compressive strength of prestressed concrete, f'c, shall be 6000 psi.

Compressive strength of prestressed concrete at release, f'ci, shall be 5000 psi.

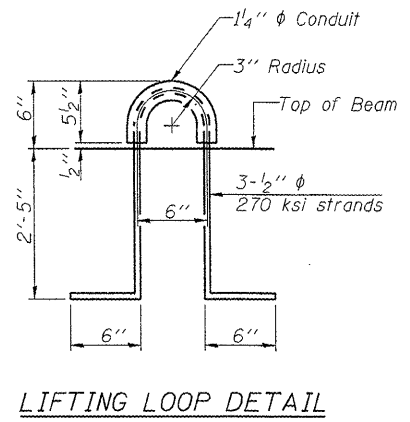
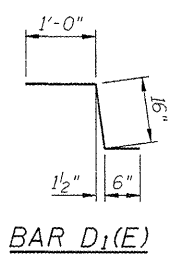
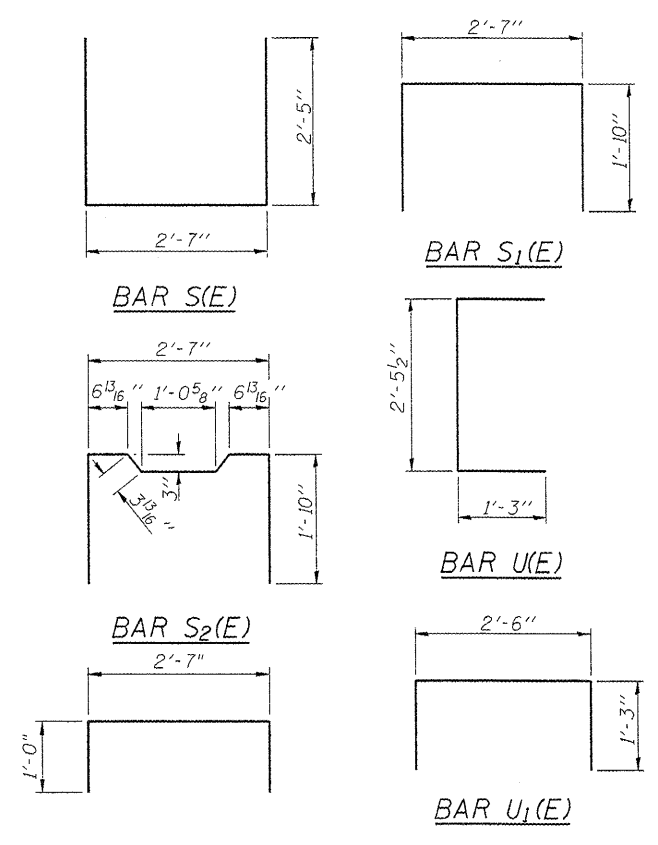

**BILL OF MATERIAL**

Precast Prestressed Conc. Deck Bms. (33 inch depth)	Sq. Ft.	3,192
---	---------	-------

**33" X 36" PPC DECK BEAM DETAILS  
STRUCTURE NO. 016-2530**

SHEET NO. 12	F.A.P. RTE.	SECTION	COUNTY	TOTAL SHEETS	SHEET NO.
	305	1415 B	COOK	75	50
15 SHEETS	CONTRACT NO. 60F60				
FED. ROAD DIST. NO. 7 ILLINOIS FED. AID PROJECT					



G:\pro\pct\2082305\CADD\Structural\Sh\162530-PPC3.dgn